

Limit Switch Installation & Operation Manual

CXAB Series

⚠️ WARNING

1. Only suitably trained personnel shall carry out installation in accordance with applicable code of practice.
2. To avoid serious or fatal personal injury or major property damage, read and follow all the instructions in this manual.
3. Hazardous voltage, disconnect all power before servicing equipment.
4. Do not exceed the electrical rating stated on label.
5. Conduit plugs supplied are for transit purpose only, remove them and install conduit or plugs suitable for protection required.
6. Save this instruction.
7. To maintain the NEMA 4 rating, the use of proper wiring methods per NEC and local codes is required.

⚠️ For switch options 10, 13, 14, 15, 16, 17 or 18 when placed in CLASS I, DIVISION 2, GROUPS A, B, C and D or CLASS II, DIVISION 2 GROUP F and G consider the following: **NO LEAD SEAL REQUIRED; ALL WIRING OF THESE DEVICES MUST BE IN ACCORDANCE WITH THE NATIONAL ELECTRICAL CODE ARTICLE 501.4(B) FOR CLASS I, DIVISION 2. WARNING - EXPLOSION HAZARD - SUBSTITUTION OF COMPONENTS MAY IMPAIR SUITABILITY FOR CLASS I, DIVISION 2. WARNING - EXPLOSION HAZARD - DO NOT DISCONNECT EQUIPMENT UNLESS POWER HAS BEEN SWITCHED OFF OR THE AREA IS KNOWN TO BE NON-HAZARDOUS. SUITABLE FOR TEMPERATURE FROM -40°C TO 80°C.**

INSTALLATION

1. Attach proper mounting bracket (1) to the switch box housing (4) using four M6x8 socket head cap screws (2) provided.
2. Align switch box shaft to top of actuator shaft and engage it.
3. Attach bracket to actuator using hardware (3) provided (finger tight only).
4. By actuating package the switch and actuator will self-align.
5. Tighten bracket to top of actuator.

SWITCH ADJUSTMENT

1. Disconnect power prior to opening lid.
2. Loosen switch box cover screws (8) and remove cover (7).
3. Rotate actuator to full clockwise position.
4. Push down top cam (5a) and turn until switch is activated and then release. Engage cam on to the splined retainer. Spring will maintain cam engagement.
5. Rotate actuator to full counter-clockwise position.
6. Pull up bottom cam (5b) and turn until switch is activated and then release. Engage cam on to the splined retainer. Spring will maintain cam engagement.
7. Place cover (7) on switch box and tighten. Take care to ensure that cover gasket seal is properly located in seal groove. Tighten screws in a cross pattern.

ELECTRICAL WIRING

1. Remove switch box cover (see switch adjustment section)
2. Remove protection plug(s) from conduit entries and install conduit or plugs suitable for type of protection required.

FOR WIRING DIAGRAM REFERS TO LABEL INSIDE THE HOUSING. FOR SWITCHES ELECTRICAL RATING REFERS TO LABEL OUTSIDE THE HOUSING.

If you require additional assistance please contact the manufacturer

WARNING: To maintain the NEMA 4X, 7 & 9 ratings, the use of proper wiring methods per NEC and local codes is required. Conduit plugs supplied with the switch box are for transit purposes only. To ensure proper protection any unused conduit entry must be closed with appropriate conduit plug.

Hazardous Areas: Class I, Div 1, Groups C, D; Class II, Div 1, Groups E, F, G; Class I, Div2, Groups A, B, C, D; Class II, Div 2, Groups F, G

3. Engage wires in terminal strip (14) using a small screwdriver (1/8" blade).

3D INDICATOR SETTING

1. Rotate actuator to closed.
2. Remove four screws (13) and remove 3D indicator cover (12).
3. Remove screw (10) and lift up 3D indicator from splined retainer.
4. Set 3D indicator (9) on splined retainer according to valve position.
5. Attach 3D indicator with (10) screw.
6. Replace 3D indicator cover (12) and fasten with cover screws (13). Check to ensure that seal (11) is properly located in seal groove.

CRANE Customer Service

3671 New Town Blvd. • St. Charles, Missouri 63301
Tel: +1-636-688-8750 • Fax: +1-636-688-8755 • www.craneenergy.com

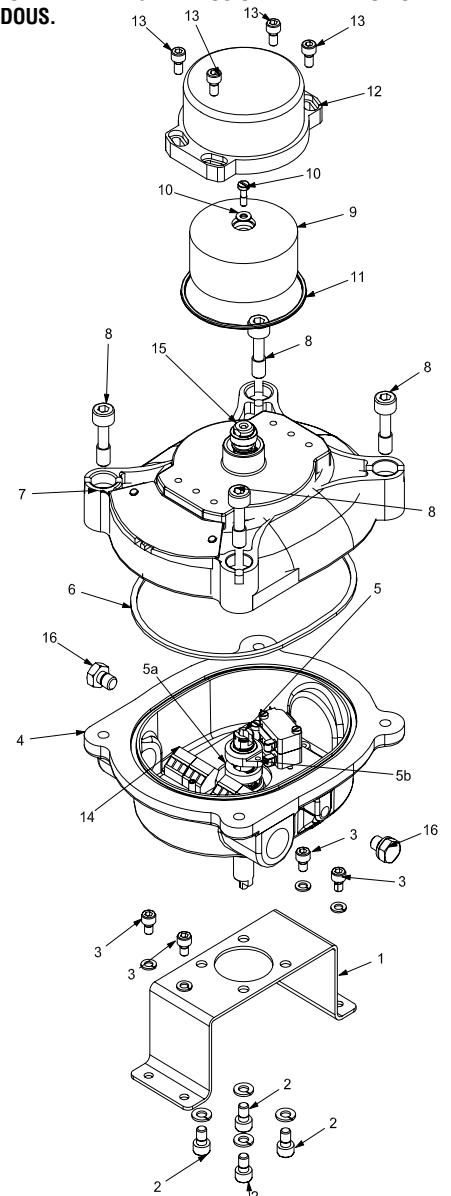

CRANE[®]

Energy Flow Solutions

Limit Switch

Installation & Operation Manual

CRANE Energy Global Headquarters

19241 David Memorial Drive, Suite 150
Shenandoah, Texas 77385
Tel: +1-936-271-6500
Fax: +1-936-271-6510

CRANE Energy Customer Service

3671 New Town Blvd.
St. Charles, Missouri 63301
Tel: +1-636-688-8750
Fax: +1-636-688-8755

www.craneenergy.com

CRANE Energy Flow Solutions[®]

brands you know...technology you want...solutions you need



Ball, Check, Corrosion Resistant Gate and Globe Valves



Lined Check and Resilient Seated Butterfly Valves

CRANE[®]

Ball, Bronze, Butterfly, Cast Steel, and Iron Valves

DUO-CHEK[®] UNI-CHEK[®]

High Performance Wafer Check Valves



High Performance Butterfly and Metal Seated Valves



Ball, Bronze, Butterfly, Cast Steel, and Iron Valves



KROMBACH
ARMATUREN

Valve System Solutions, Highly Engineered Specialty Valves

NOZ-CHEK[®] COMPAC-NOZ[®]

Nozzle-Type, Severe Service Check Valves



High Pressure and Severe Service Valves

STOCKHAM[®]

Ball, Bronze, Butterfly, Cast Steel, and Iron Valves



Cast Steel Valves

VALVE SERVICES

Certified Valve Repair Services

Aloyco, Center Line, Compac-Noz, Crane, Duo-Chek, Flowseal, Jenkins, Krombach, Noz-Chek, Pacific, Stockham, Triangle, and Uni-Chek are all trademarks of Crane Co. ©2010

EG-CR-FE-EN-L99-36-1003 (CV-1007)