

CRANE[®]

brands you trust.



CRANE[®] Iron Valves

CRANE[®]

©Copyright 2013 CRANE ChemPharma & Energy

www.cranechempharma.com
www.craneenergy.com

Key Features & Applications

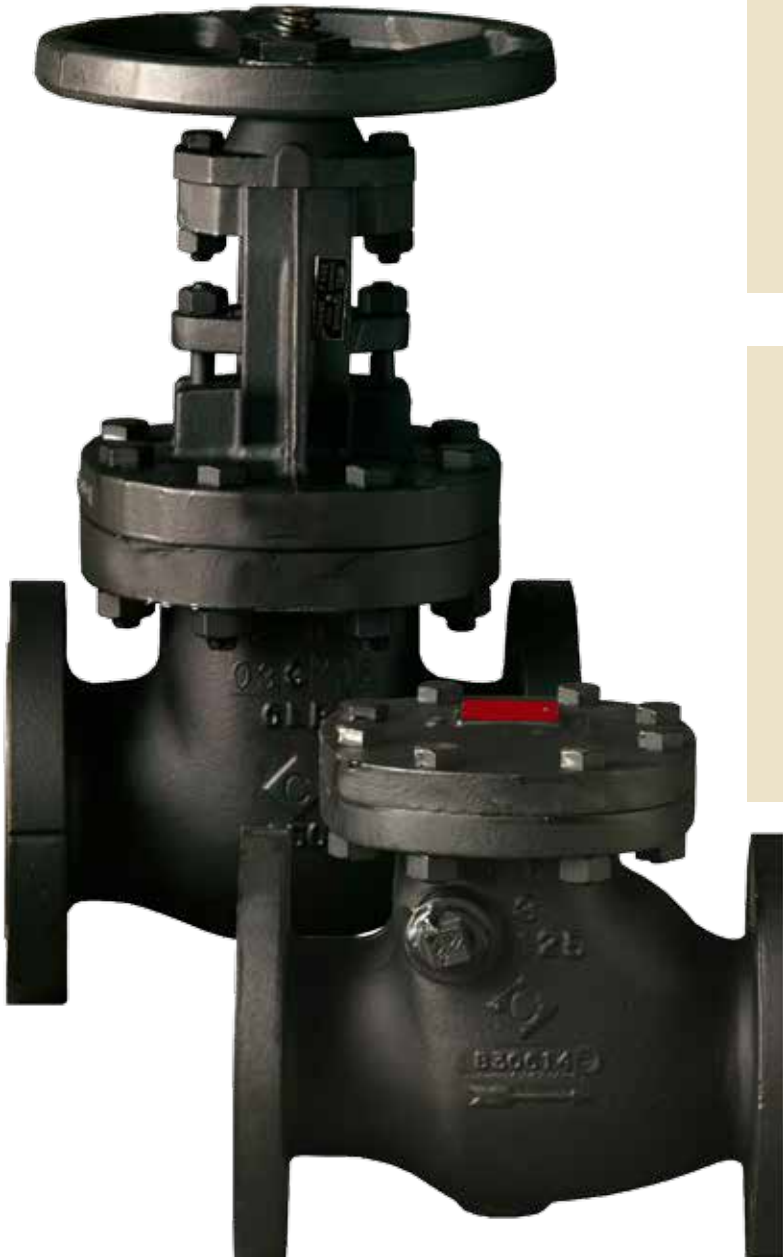

Key Features & Benefits

- 1 Fully rated to ASME and MSS-SP Standards
- 2 Full Pressure Class Offering: Class 125, Class 150, Class 250, and Class 300
- 3 Complete size range availability from 2" through 24"

Typical Applications

- Commercial Plumbing and HVAC
- Institutional HVAC
- Industrial Plumbing and HVAC
- Utility Applications

Iron Valve Selection Guide and Figure Number Index

| | |
|------------------------------------|-----|
| Cross Reference & Materials | 4 |
| Overview..... | 5-6 |
| Pressure/Temperature Ratings | 5 |
| C _v Coefficients | 5 |
| Gate Section..... | 7 |
| Globe Section | 18 |
| Check Section | 21 |
| Technical Data | 23 |
| Installation Recommendations | 26 |

| CRANE® Figure No. | Catalog Page No. | Pressure Class | Stem: RS or NRS | Body/Trim IBBM, Ductile | Bonnet/Cap: BB, TB, Clamp | End Connections | Disc |
|-------------------------------------|---------------------|---------------------------------|--------------------|----------------------------|---------------------------------|--------------------|------|
| Iron Body Gate Valves | | | | | | | |
| 460 | 7 | 125 | NRS | IBBM | BB | THD | SW |
| 461 | 8 | 125 | NRS | IBBM | BB | FLG | SW |
| 473 | 9 | 125 | NRS | AI | BB | FLG | |
| 464 ½ | 10 | 125 | RS, OS&Y | IBBM | BB | THD | |
| 465 ½ | 11 | 125 | RS, OS&Y | IBBM | BB | FLG | |
| 475 ½ | 12 | 125 | RS, OS&Y | AI | BB | FLG | |
| 488 | 13 | 125/150 | RS | Ductile Iron | Clamp | THD | |
| 488 ½ | 14 | 125/150 | RS | Ductile Iron | Clamp | FLG | |
| 490 | 15 | 125/150 | RS | IBBM Ductile Iron | Clamp | THD | |
| 3E | 16 | 250 | NRS | IBBM | BB | FLG | |
| 7 ½ E | 17 | 250 | RS, OS&Y | IBBM | BB | FLG | |
| Iron Body Globe Valves | | | | | | | |
| 351 | 18 | 125 | RS, OS&Y | IBBM | BB | FLG | BRZ |
| 21E | 20 | 250 | RS, OS&Y | IBBM | BB | FLG | BRZ |
| Iron Body Angle Valves | | | | | | | |
| 353 | 19 | 125 | RS, OS&Y | IBBM | BB | FLG | BRZ |
| Iron Body Stop Check Valves | | | | | | | |
| 28E | 21 | 250 (straight flow) | RS, OS&Y | IBBM | BB | FLG | BRZ |
| 30E | 22 | 250 (90° angle flow) | RS, OS&Y | IBBM | BB | FLG | BRZ |
| Iron Body Swing Check Valves | | | | | | | |
| 372 | 27 | 125 | | IBBM | BC | THD | BRZ |
| 373 | 28 | 125 | | IBBM | BC | FLG | BRZ |
| 373 ½ | 30 | 125 | | AI | BC | FLG | Iron |
| 383 | 29 | 125 w/outside lever & weight | | IBBM | BC | FLG | BRZ |
| 39E | 31 | 250 | | IBBM | BC | FLG | BRZ |
| 346 ½ | 32 | 300 Y-Pattern | | Ductile Iron | SC | THD | Iron |

NOTE: The following valves have been discontinued: 465, 467, 484½, 485½, 486½, 487½, 490½, 1670, 1671, 14477, 7E, 254XR, 373RS, 375, 14493. Please consult factory* for possible substitutions.

* See back cover for Customer Service information.

Cross Reference for Commonly Used Valves & Materials

IRON VALVES

| GATE | CRANE® | NIBCO | Milwaukee | Powell | Walworth | Stockham® |
|----------------------------------|--------|---------|-----------|--------|----------|-----------|
| Class 125 NRS | 461 | F-619 | F2882 A | 1787 | W719F | G-612 |
| Class 125 OS&Y | 465 ½ | F-617-0 | F2885 A | 1793 | W726F | G-623 |
| Class 250 OS&Y | 7 ½E | F-667-0 | F2894 A | 1797 | W786F | F-667 |
| GLOBE | | | | | | |
| Class 125 | 351 | F-718-B | F2981 A | 241 | W906F | G-512 |
| SWING CHECK | | | | | | |
| Class 125 | 373 | F-918-B | F2974 A | 559 | W928F | G-931 |
| STOP CHECK | | | | | | |
| Class 250 Straight-Way Y-Pattern | 28E | ---- | ---- | ---- | ---- | F-540 |
| Class 250 Angle Y-Pattern | 30E | F-869-B | ---- | ---- | ---- | F-541 |

BRONZE VALVES

| GATE | CRANE® | NIBCO | Milwaukee | Stockham® |
|------------------------|--------|----------|-----------|-----------|
| Class 125 RS-Threaded | 428 | T-111 | 148 | B-100 |
| Class 125 NRS-Threaded | 438 | T-113 | 105 | B-103 |
| Class 125 RS-Solder | 1330 | S-111 | 149 | B-108 |
| Class 125 NRS-Solder | 1320 | S-113 | 115 | B-104 |
| Class 150 Union Bonnet | 431UB | T-134 | 1151 | B-120 |
| Class 300 SS Trim | 634E | T-174-SS | 1184 | B-145 |
| GLOBE | | | | |
| Class 125 | 1 | T-211-B | 502 | B-16 |
| Class 300 SS Trim | 382P | T-275 | 593A | B-74 |
| CHECK | | | | |
| Class 125 Threaded | 37 | T-413-BY | 509 | B-319Y |
| Class 125 Solder | 1340 | S-413-B | 1509 | B-309Y |
| Class 300 Swing Check | 76E | T-473-B | 507 | B-375 |
| Class 300 Lift Check | 366E | ---- | ---- | B-367 |

Materials

CAST IRON - ASTM A126, CLASS B

| Used primarily for valve pressure retaining parts. Recommended to 450 °F (232 °C). | | |
|---|---------|---------|
| Chemical Requirements | Minimum | Maximum |
| Sulphur % | - | 0.15 |
| Phosphorus % | - | 0.75 |
| Tensile Requirements | Minimum | Maximum |
| Tensile Strength, psi | 31,000 | - |
| Transverse Test Load, lbs. | 3,300 | - |
| Deflection @ Center, in. | 0.12 | |

BRONZE

| |
|------------------|
| ASTM B584 C84400 |
| ASTM B584 C86400 |
| ASTM B61 C92200 |
| ASTM B16 C36000 |
| ASTM B62 C83600 |

DUCTILE IRON - ASTM A536, 65-45-12

| Chemical Requirements | Minimum % | Maximum % |
|-----------------------|-------------------|-----------|
| Carbon (C) | 3.5 | 3.9 |
| Manganese (Mn) | 0.15 | 0.35 |
| Silicone (Si) | 2.25 | 2.75 |
| Sulphur (S) | 0.01 | 0.025 |
| Phosphorus (P) | | 0.05 |
| Tensile Requirements | Minimum | Maximum |
| Tensile Strength, psi | 65,000 Minimum | |
| Yield Strength, psi | 45,000 Minimum | |
| Elongation (in 2") | 12% | |

Overview

CRANE® iron body valves are proven performers in mechanical systems of commercial buildings throughout America. Chemical plants, steel mills, shipyards, refineries, pulp and paper mills, and utilities have also found that CRANE® iron body valves do the job better and longer for their many general services.

QUALITY MANAGEMENT

CRANE® is committed to a philosophy of total quality management. It begins with design, to comply with pertinent MSS and ASME Standards. Continuous improvements are applied in a process to improve materials and services to meet or exceed customer needs.

MATERIALS

The iron used as the basic valve material conforms to the chemical and physical requirements of the American Society of Testing and Materials A-126 Class B for Cast Iron Valves.

RATED WORKING PRESSURES

The pressure-temperature ratings of CRANE® iron body valves in this catalog section are as follows:

| Temp. °F | PRESSURE (PSIG) | | | |
|-------------|------------------------|-------|------------------------|-------|
| | Class 125 Cast Iron | | Class 250 Cast Iron | |
| | Sizes | Sizes | Sizes | Sizes |
| | 2-12 | 14-24 | 2-12 | 14-2 |
| -20 to 100 | 200 | 150 | 500 | 300 |
| 150 | 200 | 150 | 500 | 300 |
| 200 | 190 | 135 | 460 | 280 |
| 225 | 180 | 130 | 440 | 270 |
| 250 | 175 | 125 | 415 | 260 |
| 275 | 170 | 120 | 395 | 250 |
| 300 | 165 | 110 | 375 | 240 |
| 325 | 155 | 105 | 355 | 230 |
| 350 | 150 | 100 | 335 | 220 |
| 375 | 145 | | 315 | 210 |
| 400 | 140 | | 290 | 200 |
| 425 | 130 | | 270 | |
| 450 | 125 | | 250 | |
| 500 | | | | |
| 600 | | | | |
| 650 | | | | |

The temperature shown for a corresponding pressure rating is the temperature of the pressure containing shell of the component. In general, this temperature is the same as that of the contained fluid. Composition disc valves are excluded from these ratings.

DESIGN

GATE VALVES-CLASSES 125 and 250

Stem—All stems are designed for ample strength and are machined to function easily. Backseats are provided on OS&Y valves.

Packing Gland Assembly—Glands and gland flanges have a ball and socket joint which assures alignment. It provides for proper packing compression without binding against the stem.

Gasket—Aramid fibers with SBR binder.

Packing—Braided flexible graphite with corrosion inhibitor or as specified with specific item.

Disc—Strong, solid wedge discs have disc guides for precision seating with minimum friction against body seats.

Yoke and Bonnet—One-piece yoke bonnets are utilized on 12" and smaller size OS&Y valves. Larger sizes have separate yokes and bonnets.

Stuffing Box—NRS valves have stuffing boxes assembled to bonnets to accommodate the packing gland assembly.

Seat Ring—Buttress-type seat rings are bottom-seated with accurately machined faces to match disc faces.

Handwheel or Operating Nut—Handwheels have large diameters for good leverage on operating nuts, a 2" square may be furnished on any NRS valve if specified.

Cv Coefficients*

(For estimating purposes only)

| Size | Gate | Globe | Swing Check |
|------|--------|-------|-------------|
| 2 | 327 | 50 | 131 |
| 2½ | 480 | 74 | 192 |
| 3 | 742 | 114 | 297 |
| 4 | 1314 | 202 | 526 |
| 5 | 2129 | 327 | 852 |
| 6 | 3175 | 487 | 1270 |
| 8 | 5691 | 873 | 2276 |
| 10 | 8970 | 1376 | 3588 |
| 12 | 13351 | — | 5340 |
| 14 | 16277 | — | 6511 |
| 16 | 21562 | — | 8625 |
| 18 | 28715 | — | 11486 |
| 20 | 35760 | — | 14304 |
| 24 | 52165 | — | 20866 |
| 30 | 82563 | — | — |
| 36 | 119910 | — | — |

*Fully open. Cv=GPM @ 1 PSI ΔP, 60°F Water

The above values for Swing Check Valves are correct only when the valve is fully open. This corresponds to a velocity of 6 ft./sec. for water flow.

Overview

Yoke Bushing—Yoke bushings on OS&Y valves have Acme threads for stem engagement; and handwheels fit snugly over bushings. Handwheels are securely locked to yoke bushings with locknuts. A bolted yoke cap secures the yoke bushing to the yoke.

Body—Body sections are evenly distributed for maximum strength. Dimensions and drilling of end flanges of cast iron valves conform to the ASME Standard B16.1 for Classes 125 and 250 Cast Iron Flanges. Face-to-face dimensions comply with ASME Standard B16.10.

DESIGN:

GLOBE AND ANGLE VALVES-OUTSIDE SCREW AND YOKE-CLASSES 125 and 250

CRANE® globe valves are highly efficient for services requiring frequent operations and throttling with pressure drop across the valve and about 20% of inlet pressure. Closer throttling, creating higher pressure drops, may cause cavitation or excessive velocities which could cause high noise levels, vibration and possible damage to the valve or adjacent piping.

Stem—Stems are machined with Acme threads which fully engage the yoke bushing threads at all times.

Packing Gland Assembly—Glands and gland flanges have a ball and socket joint which assures alignment and proper packing compression.

Packing—Braided flexible graphite with corrosion inhibitor or as specified with specific item.

Backseat Bushing—Bushings are threaded into bonnets, providing beveled seats for backseating on stem shoulders.

Disc—Bronze discs are furnished in Class 125 and 250 globe and angle valves, which are regrindable. Disc nuts thread into disc. The Class 250 nonreturn stop-check valve conforms to ASME boiler codes and utilizes a dashpot and piston design to cushion the disc action.

Yoke Bonnet—One-piece yoke bonnets are fastened to bodies with capscrews.

Seat Rings—Seat rings are bottom-seated and are readily renewable.

Handwheel—Handwheels have large diameters for ample leverage.

Yoke Bushing—Accurate Acme threads engage stem threads. Set screws fasten yoke bushings to yoke.

Body—Bodies are designed with uniform sections evenly distributed for maximum strength. Dimensions and drilling of end flanges on flanged valves conform to the ASME Standard B16.1 for Classes 125 and 250 Cast Iron Flanges. Face-to-face dimensions comply with the ASME Standard B16.10.

DESIGN:

SWING CHECK VALVES-CLASSES 125 and 250

Cap—Caps are bolted to bodies.

Hinge—Hinges are precisely drilled for assembly with discs.

Hinge Pin—Pins are located by side plugs, screwed into bodies.

Disc—Disc faces are accurately machined for tight seal with seat rings.

Seat Ring—Buttress design of renewable seat rings provides bottom seating and good strength.

Body—Dimensions and drilling of end flanges on flanged valves conform to ASME Standard B16.1 for Classes 125 and 250 Cast Iron Flanges. Face-to-face dimensions comply with ASME B16.10.

Figure 383 L&W:

Swing Check valves sized 2"-12" come standard with an adjustable lever arm which can be orientated in any position in 15° increments. These valves can be installed in horizontal lines or in vertical lines with upward flow. 14"-24" valves must be specified at the time of inquiry and order with the installation orientation for horizontal or vertical-upward flow.

ACCESSORIES—CRANE® iron body valves may be furnished with motor operators, gearings, bypasses, floorstands, extension stems, lever and weight attachment or other accessories.

MARKING—Numerals indicate the size and pressure class. Cast arrows indicate direction of flow on check, globe, and angle valves.

TESTING AND INSPECTION—Before shipment, each valve is individually tested under pressure for soundness of castings and tight closure to MSS Standards.

FINISH—External cast iron parts are coated with a durable black finish.

WEIGHTS AND DIMENSIONS—Dimensions and weights shown in this catalog section are furnished for estimating purposes only and are subject to change without notice. It is our intent to maintain basic dimensional requirements of accepted standards.

Class 125 • Bolted Bonnet • N-R Stem • Bronze Trim • Threaded

460 Gate Valve

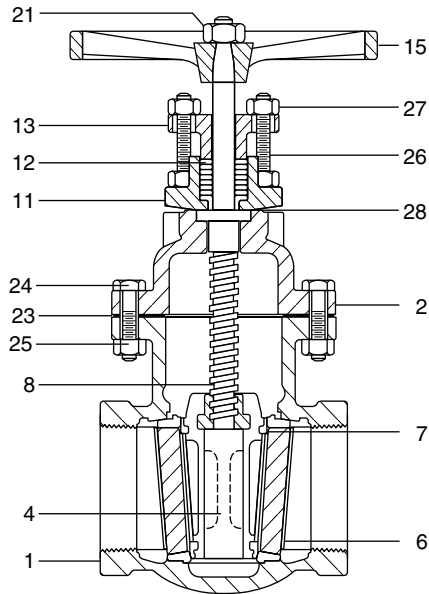

Materials of Construction

| No. | Description | Material | ASTM |
|-----|------------------------|--|-------------------|
| 1 | Body | Cast Iron | A126 Class B |
| 2 | Bonnet | Cast Iron | A126 Class B |
| 4 | Disc | Bronze (2" - 3") | B584 C84400 |
| | | Cast Iron (4") | A126 Class B |
| 6 | Seat Ring | Bronze | B584 C84400 |
| 7 | Disc Ring | Bronze (4") | B584 C84400 |
| 8 | Stem | Manganese Bronze | B584 C86400 |
| 11 | Stuffing Box | Ductile Iron | A536 Gr. 65-45-12 |
| 12 | Packing | Braided Flexible Graphite with Corrosion Inhibitor | |
| 13 | Gland Flange | Ductile Iron | A536 Gr. 65-45-12 |
| 15 | Handwheel | Ductile Iron | A536 Gr. 65-45-12 |
| 21 | Handwheel Nut | Carbon Steel | A563 Gr. A |
| 23 | Bonnet Gasket | Aramid Fibers with SBR Binder | |
| 24 | Bonnet Bolt | Carbon Steel | A307 Gr. B |
| 25 | Bonnet Bolt Nut | Carbon Steel | A563 Gr. A |
| 26 | Gland Bolt | Carbon Steel | A307 Gr. B |
| 27 | Gland Bolt Nut | Carbon Steel | A563 Gr. A |
| 28 | Stuffing Box Gasket | Aramid Fibers with SBR Binder | |
| 34 | Stuffing Box Bolt* | Carbon Steel | A307 Gr. B |
| 35 | Stuffing Box Bolt Nut* | Carbon Steel | A563 Gr. A |

* Not shown

See page 5 for Pressure Temperature Ratings

Industry Standards

MSS SP-70, Type 1

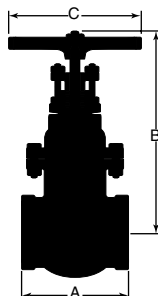

Dimensions and Weights

Inches (millimeters) - Pounds (kilograms)

| Valve Size | Dimensions | | | WT |
|------------|------------|-------|-------|------|
| | A | B | C | |
| 2 | 5.38 | 11.31 | 8.00 | 25 |
| | (137) | (287) | (203) | (11) |
| 2 ½ | 6.62 | 12.40 | 8.00 | 31 |
| | (168) | (315) | (203) | (14) |
| 3 | 7.00 | 13.25 | 8.00 | 44 |
| | (178) | (337) | (203) | (20) |
| 4 | 8.00 | 16.31 | 10.00 | 71 |
| | (203) | (414) | (254) | (32) |

Class 125 • Bolted Bonnet • N-R Stem • Bronze Trim • Flanged

461 Gate Valve

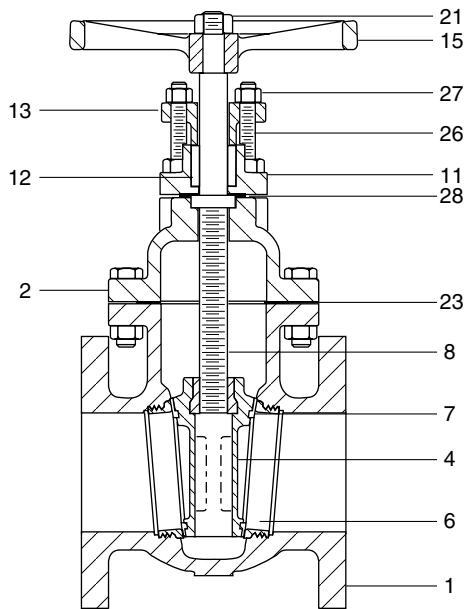

Dimensions and Weights Inches (millimeters) - Pounds (kilograms)

| Valve Size | Dimensions | | | WT |
|------------|------------|-------|-------|--------|
| | B | C | M | |
| 2 | 11.31 | 8.00 | 7.00 | 30 |
| | (287) | (203) | (178) | (14) |
| 2 ½ | 12.40 | 8.00 | 7.50 | 40 |
| | (315) | (203) | (191) | (18) |
| 3 | 13.25 | 8.00 | 8.00 | 56 |
| | (337) | (203) | (203) | (25) |
| 4 | 16.31 | 10.00 | 9.00 | 90 |
| | (414) | (254) | (229) | (41) |
| 5 | 18.00 | 10.00 | 10.00 | 126 |
| | (457) | (254) | (254) | (57) |
| 6 | 20.69 | 12.00 | 10.50 | 152 |
| | (526) | (305) | (267) | (68) |
| 8 | 24.12 | 14.00 | 11.50 | 260 |
| | (613) | (356) | (292) | (117) |
| 10 | 33.00 | 20.00 | 13.00 | 490 |
| | (838) | (508) | (330) | (222) |
| 12 | 36.50 | 20.00 | 14.00 | 672 |
| | (927) | (508) | (356) | (304) |
| 14 | 40.50 | 20.00 | 15.00 | 968 |
| | (1029) | (508) | (381) | (440) |
| 16 | 48.00 | 22.00 | 16.00 | 1180 |
| | (1219) | (559) | (406) | (535) |
| 18 | 50.75 | 22.00 | 17.00 | 1701 |
| | (1289) | (559) | (432) | (772) |
| 20 | 56.12 | 24.00 | 18.00 | 2188 |
| | (1426) | (610) | (457) | (993) |
| 24 | 64.00 | 30.00 | 20.00 | 3150 |
| | (1626) | (762) | (508) | (1432) |

Materials of Construction

| No. | Description | Material | ASTM |
|-----|------------------------|--|-------------------|
| 1 | Body | Cast Iron | A125 Class D |
| 2 | Bonnet | Cast Iron | A126 Class B |
| 4 | Disc | Bronze (2" - 3") | B584 C84400 |
| | | Cast Iron (4" - 24") | A126 Class B |
| 6 | Seat Ring | Bronze (2" - 12") | B584 C84400 |
| | | Bronze (14" - 24") | B584 C84400 |
| 7 | Disc Ring | Bronze (4" - 12") | B584 C84400 |
| | | Bronze (14" - 24") | B584 C84400 |
| 8 | Stem | Manganese Bronze (2" - 12") | B584 C86400 |
| | | Copper-Silicon Bronze (14" - 24") | |
| 11 | Stuffing Box | Ductile Iron (2" - 8") | A536 Gr. 65-45-12 |
| | | Cast Iron (10" - 24") | A126 Class B |
| 12 | Packing | Braided Flexible Graphite with Corrosion Inhibitor | |
| 13 | Gland Flange | Ductile Iron (2" - 8") | A536 Gr. 65-45-12 |
| | | Ductile Iron (14" - 24") | A536 Gr. 65-45-12 |
| 14 | Gland* | Bronze (10" - 12") | B584 C84400 |
| 15 | Handwheel | Ductile Iron | A536 Gr. 65-45-12 |
| 21 | Handwheel Nut | Carbon Steel | A563 Gr. A |
| 23 | Bonnet Gasket | Aramid Fibers with SBR Binder | |
| 24 | Bonnet Bolt* | Carbon Steel | A307 Gr. B |
| 25 | Bonnet Bolt Nut* | Carbon Steel | A563 Gr. A |
| 26 | Gland Bolt | Carbon Steel | A307 Gr. B |
| 27 | Gland Bolt Nut | Carbon Steel | A563 Gr. A |
| 28 | Stuffing Box Gasket | Aramid Fibers with SBR Binder | |
| 34 | Stuffing Box Bolt* | Carbon Steel | A307 Gr. B |
| 35 | Stuffing Box Bolt Nut* | Carbon Steel | A563 Gr. A |
| 55 | Gland Follower* | Ductile Iron (10" - 12") | A536 Gr. 65-45-12 |

* Not shown

See page 5 for Pressure Temperature Ratings

Industry Standards

MSS SP-70, Type 1

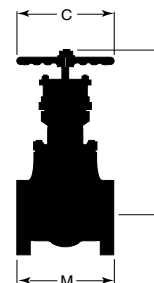

Class 125 • Bolted Bonnet • N-R Stem • All Iron • Flanged

473 Gate Valve

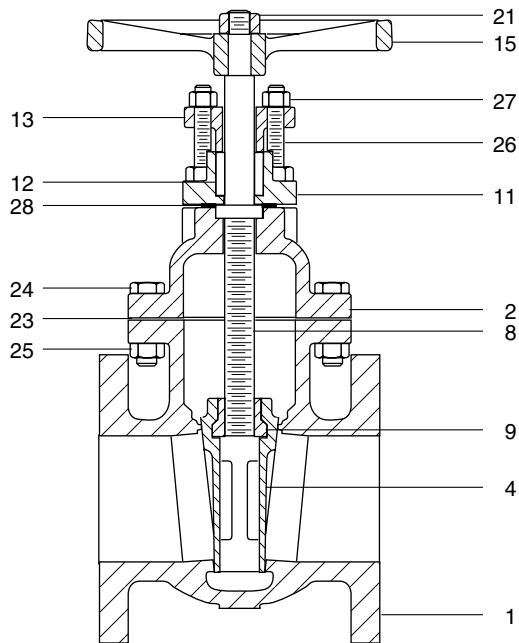

Materials of Construction

| No. | Description | Material | ASTM |
|-----|------------------------|--|-------------------|
| 1 | Body | Cast Iron | A126 Class B |
| 2 | Bonnet | Cast Iron | A126 Class B |
| 4 | Disc | Cast Iron | A126 Class B |
| 8 | Stem | Stainless Steel | A276 Type 304 |
| 9 | Disc Nut | 13 CR SS (4" - 8") | A582 Type 416 |
| 11 | Stuffing Box | Ductile Iron | A536 Gr. 65-45-12 |
| 12 | Packing | Braided Flexible Graphite with Corrosion Inhibitor | |
| 13 | Gland Flange | Ductile Iron | A536 Gr. 65-45-12 |
| 15 | Handwheel | Ductile Iron | A536 Gr. 65-45-12 |
| 21 | Handwheel Nut | Carbon Steel | A563 Gr. A |
| 23 | Bonnet Gasket | Aramid Fibers with SBR Binder | |
| 24 | Bonnet Bolt | Carbon Steel | A307 Gr. B |
| 25 | Bonnet Bolt Nut | Carbon Steel | A563 Gr. A |
| 26 | Gland Bolt | Carbon Steel | A307 Gr. B |
| 27 | Gland Bolt Nut | Carbon Steel Zinc-Plated | A563 Gr. A |
| 28 | Stuffing Box Gasket | Aramid Fibers with SBR Binder | |
| 34 | Stuffing Box Bolt* | Carbon Steel | A307 Gr. B |
| 35 | Stuffing Box Bolt Nut* | Carbon Steel | A563 Gr. A |

* Not shown

See page 5 for Pressure Temperature Ratings

Industry Standards

MSS SP-70, Type 1

Dimensions and Weights

Inches (millimeters) - Pounds (kilograms)

| Valve Size | Dimensions | | | WT |
|------------|----------------|----------------|----------------|--------------|
| | B | C | M | |
| 2 | 11.31 (287) | 8.00 (203) | 7.00 (178) | 30 (14) |
| | 12.40 (315) | 8.00 (203) | 7.50 (191) | 44 (20) |
| 3 | 13.25 (337) | 8.00 (203) | 8.00 (203) | 56 (25) |
| | 16.31 (414) | 10.00 (254) | 9.00 (229) | 91 (41) |
| 5 | 18.00 (457) | 10.00 (254) | 10.00 (254) | 126 (57) |
| | 20.69 (526) | 12.00 (305) | 10.50 (267) | 152 (69) |
| 8 | 24.12 (613) | 14.00 (356) | 11.50 (292) | 260 (118) |

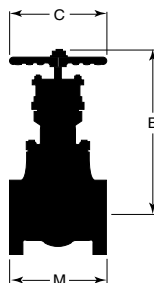

Class 125 • Bolted Bonnet • OS&Y • Bronze Trim • Threaded

464 1/2 Gate Valve

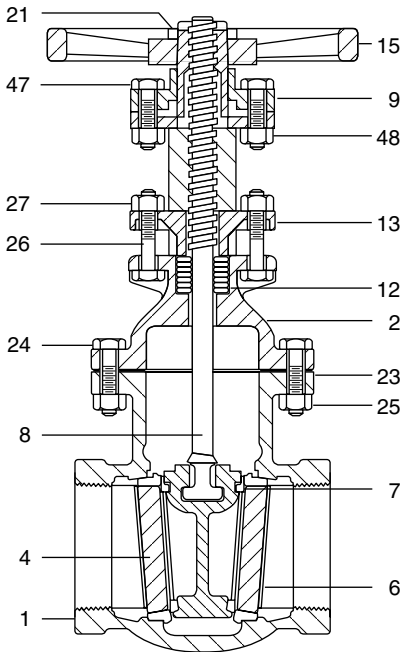

Materials of Construction

| No. | Description | Material | ASTM |
|-----|-------------------|--|-------------------------|
| 1 | Body | Cast Iron | A126 Class B |
| 2 | Yoke Bonnet | Cast Iron | A126 Class B |
| 4 | Disc | Bronze (2") | B61 C92200 |
| | | Bronze (2 1/2" - 3") | B584 C84400 |
| | | Cast Iron (4") | A126 Class B |
| 6 | Seat Ring | Bronze | B584 C84400 |
| 7 | Disc Ring | Bronze (4") | B584 C84400 |
| 8 | Stem | Manganese Bronze | B584 C86400 |
| 9 | Yoke Sleeve | Manganese Bronze | B584 C86400 |
| 12 | Packing | Braided Flexible Graphite with Corrosion Inhibitor | |
| 13 | Gland | Ductile Iron | A536 Gr. 65-45-12 |
| 15 | Handwheel | Ductile Iron | A536 Gr. 65-45-12 |
| 21 | Handwheel Nut | Sintered Nickel Steel | B484 Gr. 2 CL B Type II |
| 23 | Bonnet Gasket | Aramid Fibers with SBR Binder | |
| 24 | Bonnet Bolt | Carbon Steel | A307 Gr. B |
| 25 | Bonnet Bolt Nut | Carbon Steel | A563 Gr. A |
| 26 | Gland Bolt | Carbon Steel | A307 Gr. B |
| 27 | Gland Bolt Nut | Carbon Steel Zinc-Plated | A563 Gr. A |
| 46 | Yoke Cap* | Ductile Iron | A536 Gr. 65-45-12 |
| 47 | Yoke Cap Bolt | Carbon Steel | A307 Gr. B |
| 48 | Yoke Cap Bolt Nut | Carbon Steel | A563 Gr. A |

* Not shown

See page 5 for Pressure Temperature Ratings

Industry Standards

MSS SP-70, Type 1

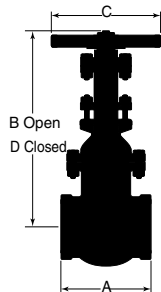

Dimensions and Weights

Inches (millimeters) - Pounds (kilograms)

| Valve Size | Dimensions | | | | WT |
|------------|------------|-------|-------|-------|------|
| | A | B | C | D | |
| 2 | 5.38 | 14.75 | 8.00 | 12.50 | 25 |
| | (137) | (375) | (203) | (318) | (11) |
| 2 1/2 | 6.62 | 16.06 | 8.00 | 13.31 | 38 |
| | (168) | (408) | (203) | (338) | (17) |
| 3 | 7.00 | 17.38 | 8.00 | 13.88 | 46 |
| | (178) | (441) | (203) | (353) | (21) |
| 4 | 8.00 | 21.44 | 10.00 | 17.06 | 77 |
| | (203) | (545) | (254) | (433) | (35) |

Class 125 • Bolted Bonnet • OS&Y • Bronze Trim • Flanged

465 1/2 Gate Valve

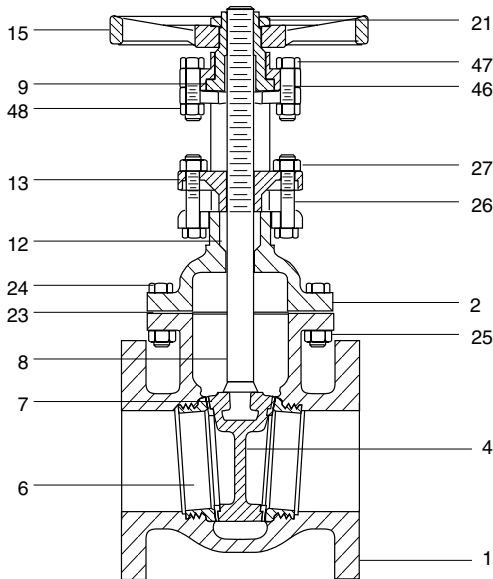

Dimensions and Weights
Inches (millimeters) - Pounds (kilograms)

| Valve Size | Dimensions | | | WT |
|------------|------------|-------|-------|--------|
| | B | C | M | |
| 2 | 14.75 | 8.00 | 7.00 | 33 |
| | (375) | (203) | (178) | (15) |
| 2 1/2 | 16.06 | 8.00 | 7.50 | 47 |
| | (408) | (203) | (191) | (21) |
| 3 | 17.38 | 8.00 | 8.00 | 58 |
| | (441) | (203) | (203) | (26) |
| 4 | 21.44 | 10.00 | 9.00 | 97 |
| | (545) | (254) | (229) | (44) |
| 5 | 25.81 | 10.00 | 10.00 | 135 |
| | (656) | (254) | (254) | (61) |
| 6 | 30.31 | 12.00 | 10.50 | 162 |
| | (770) | (305) | (267) | (73) |
| 8 | 37.75 | 14.00 | 11.50 | 280 |
| | (959) | (356) | (292) | (126) |
| 10 | 49.41 | 18.00 | 13.00 | 502 |
| | (1255) | (457) | (330) | (228) |
| 12 | 56.81 | 18.00 | 14.00 | 670 |
| | (1442) | (457) | (356) | (304) |
| 14 | 64.88 | 20.00 | 15.00 | 1093 |
| | (1648) | (508) | (381) | (496) |
| 16 | 75.25 | 22.00 | 16.00 | 1425 |
| | (1911) | (559) | (406) | (647) |
| 18 | 82.00 | 22.00 | 17.00 | 1738 |
| | (2083) | (559) | (432) | (789) |
| 20 | 90.62 | 24.00 | 18.00 | 2085 |
| | (2302) | (610) | (457) | (946) |
| 24 | 105.38 | 30.00 | 20.00 | 3183 |
| | (2677) | (762) | (508) | (1445) |

Materials of Construction

| No. | Description | Material | ASTM |
|-----|----------------------|--|-------------------------|
| 1 | Body | Cast Iron | A126 Class B |
| 2 | Bonnet | Cast Iron | A126 Class B |
| 4 | Disc | Bronze (2") | B61 C92200 |
| | | Bronze (2 1/2" & 3") | B584 C84400 |
| | | Cast Iron (4" - 24") | A126 Class B |
| 6 | Body Seat Ring | Bronze | B584 C84400 |
| 7 | Disc Seat Ring | Bronze | B584 C84400 |
| 8 | Stem | Manganese Bronze (2" - 12") | B584 C86400 |
| | | Brass (14" - 36") | |
| 9 | Yoke Sleeve | Manganese Bronze (2" - 12") | B584 C86400 |
| | | Ductile Iron (14" - 24") | A536 Gr. 65-45-12 |
| 10 | Gland* | Bronze (10" & 12") | B584 C84400 |
| | Gland Flange* | Ductile Iron (10" & 12") | A536 Gr. 65-45-12 |
| 12 | Packing | Braided Flexible Graphite with Corrosion Inhibitor | |
| 15 | Handwheel | Ductile Iron | A536 Gr. 65-45-12 |
| 21 | Handwheel Nut | Sintered Nickel Steel (2" - 8") | B484 Gr. 2 CL B Type II |
| | | Ductile Iron (10" - 24") | A536 Gr. 65-45-12 |
| 23 | Bonnet Gasket | Aramid Fibers with SBR Binder | |
| 24 | Bonnet Bolt | Carbon Steel | A307 Gr. B |
| 25 | Bonnet Bolt Nut | Carbon Steel | A563 Gr. A |
| 26 | Gland Bolt | Carbon Steel (2" - 12") | A307 Gr. B |
| 26 | Gland Eyebolt* | Carbon Steel (14" - 24") | |
| 27 | Gland Bolt Nut | Carbon Steel | A563 Gr. A |
| 46 | Yoke Cap | Ductile Iron (2" - 8") | A536 Gr. 65-45-12 |
| | | Cast Iron (10" - 12") | A126 Class B |
| 47 | Yoke Cap Bolt | Carbon Steel (2" - 12") | A307 Gr. B |
| 48 | Yoke Cap Bolt Nut | Carbon Steel (2" - 12") | A563 Gr. A |
| 49 | Stem Collar Seat* | Brass (14" - 24") | |
| 50 | Disc Pin* | Brass (14" - 24") | |
| 51 | Yoke Bolt* | Carbon Steel (14" - 24") | |
| 52 | Yoke Bolt Nut* | Carbon Steel (14" - 24") | |
| 53 | Yoke to Bonnet Bolt* | Carbon Steel (14" - 24") | |
| 54 | Backseat Bushing* | Brass (14" - 24") | |
| 55 | Eyebolt Pin* | Carbon Steel (14" - 24") | |
| 56 | Yoke* | Cast Iron (14" - 24") | |

* Not shown
See page 5 for Pressure Temperature Ratings

Industry Standards

MSS SP-70, Type 1

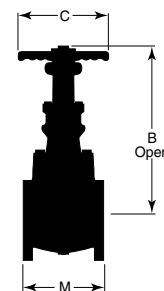

Class 125 • Bolted Bonnet • OS&Y • All Iron • Flanged

475 1/2 Gate Valve

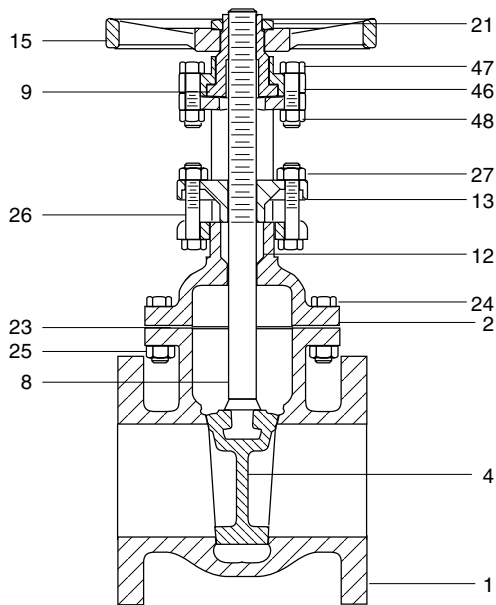

Dimensions and Weights Inches (millimeters) - Pounds (kilograms)

| Valve Size | Dimensions | | | WT |
|------------|------------|-------|-------|--------|
| | B | C | M | |
| 2 | 14.75 | 8.00 | 7.00 | 33 |
| | (375) | (203) | (178) | (15) |
| 2 1/2 | 16.06 | 8.00 | 7.50 | 47 |
| | (408) | (203) | (191) | (21) |
| 3 | 17.38 | 8.00 | 8.00 | 58 |
| | (441) | (203) | (203) | (26) |
| 4 | 21.44 | 10.00 | 9.00 | 97 |
| | (545) | (254) | (229) | (44) |
| 5 | 25.81 | 10.00 | 10.00 | 135 |
| | (656) | (254) | (254) | (61) |
| 6 | 30.31 | 12.00 | 10.50 | 162 |
| | (770) | (305) | (267) | (73) |
| 8 | 37.75 | 14.00 | 11.50 | 280 |
| | (959) | (356) | (292) | (126) |
| 10 | 49.41 | 18.00 | 13.00 | 502 |
| | (1255) | (475) | (330) | (228) |
| 12 | 56.81 | 18.00 | 14.00 | 670 |
| | (1442) | (457) | (356) | (304) |
| 14 | 64.38 | 20.00 | 15.00 | 1093 |
| | (1635) | (508) | (381) | (497) |
| 16 | 75.25 | 22.00 | 16.00 | 1425 |
| | (1911) | (559) | (406) | (647) |
| 18 | 82.00 | 22.00 | 17.00 | 1738 |
| | (2083) | (559) | (432) | (790) |
| 20 | 90.62 | 24.00 | 18.00 | 2085 |
| | (2302) | (610) | (457) | (911) |
| 24 | 105.28 | 30.00 | 20.00 | 3183 |
| | (2674) | (762) | (508) | (1446) |

Materials of Construction

| No. | Description | Material | ASTM |
|-----|-------------------|--|-------------------------|
| 1 | Body | Cast Iron | A126 Class B |
| 2 | Bonnet | Cast Iron | A126 Class B |
| 4 | Disc | Cast Iron | A126 Class B |
| 6 | Seat Ring* | Cast Iron (12" - 24") | A126 Class B |
| 8 | Stem | Carbon Steel, Nickel-Plated | A108 |
| 9 | Yoke Sleeve | Manganese Bronze | B584 C86400 |
| 12 | Packing | Braided Flexible Graphite with Corrosion Inhibitor | |
| 13 | Gland | Ductile Iron (2" - 8") | A536 Gr. 65-45-12 |
| | | Carbon Steel Zinc-Plated (10" - 24") | A108 |
| 15 | Handwheel | Ductile Iron | A536 Gr. 65-45-12 |
| 21 | Handwheel Nut | Sintered Nickel Steel (2" - 10") | B484 Gr. 2 CL B Type II |
| | | Ductile Iron (12" - 24") | A536 Gr. 65-45-12 |
| 23 | Bonnet Gasket | Aramid Fibers with SBR Binder | |
| 24 | Bonnet Bolt | Carbon Steel | A307 Gr. B |
| 25 | Bonnet Bolt Nut | Carbon Steel | A563 Gr. A |
| 26 | Gland Bolt | Carbon Steel | A307 Gr. B |
| 27 | Gland Bolt Nut | Carbon Steel Zinc-Plated | A563 Gr. A |
| 46 | Yoke Cap | Ductile Iron | A536 Gr. 65-45-12 |
| 47 | Yoke Cap Bolt | Carbon Steel | A307 Gr. B |
| 48 | Yoke Cap Bolt Nut | Carbon Steel | A563 Gr. A |
| 55 | GLD Follower* | Ductile Iron (10" - 24") | A536 Gr. 65-45-12 |

* Not shown

See page 5 for Pressure Temperature Ratings

Industry Standards

MSS SP-70, Type 1

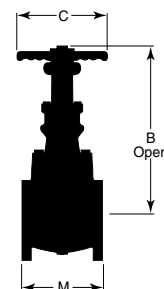

Class 150 • U-Bolt Bonnet • Rising Stem • All Iron • Threaded

488 Gate Valve

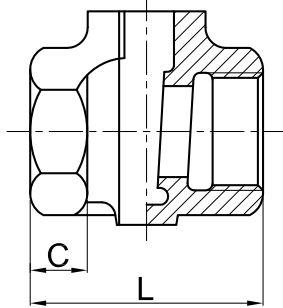
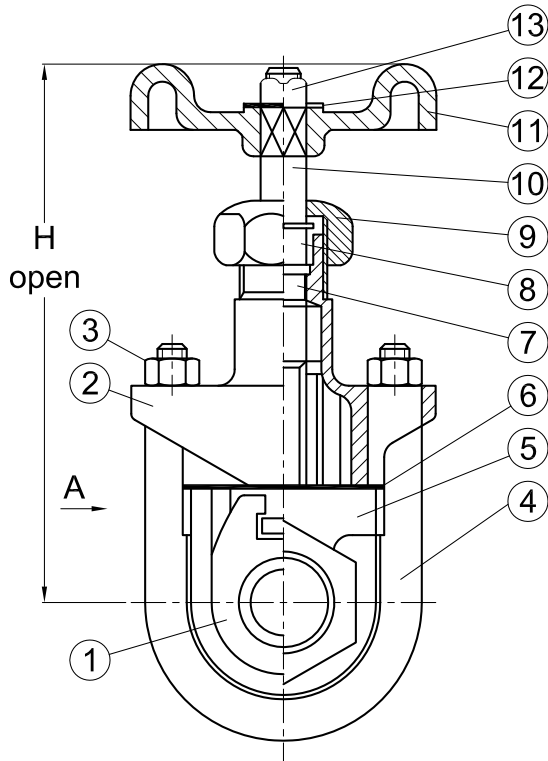

VIEW A

| Size | Pressure Rating |
|---------|-------------------------|
| ¼ - 2" | 225 PSI WOG (Non-Shock) |
| 2½ - 4" | 175 PSI WOG (Non-Shock) |

Materials of Construction

| No. | Description | Material | ASTM |
|-----|-------------|----------------------------------|------------|
| 1 | Disc | Ductile Iron | A536 |
| 2 | Bonnet | Ductile Iron | A536 |
| 3 | Nut | Steel ASTM | A563 |
| 4 | "U"-Bolt | Steel ASTM | A307 |
| 5 | Body | Ductile Iron | A536 |
| 6 | Gasket | Aramid Fiber with Nitrile Binder | |
| 7 | Packing | Die-formed Compressed Graphite | |
| 8 | Gland | Stainless Steel | A276-410 |
| 9 | Packing Nut | Ductile Iron | A536 |
| 10 | Stem | Stainless Steel | A276-410 |
| 11 | Handwheel | Cast Iron | A126 Gr. B |
| 12 | Name Plate | Aluminum | |
| 13 | Wheel Nut | Steel | A563 Gr. A |

* Not shown

See page 5 for Pressure Temperature Ratings

Industry Standards

MSS SP-70

ASME B16.42

Dimensions and Weights

Inches (millimeters) - Pounds (kilograms)

| Valve Size | Dimensions | | | WT |
|------------|------------|-------|--------|--------|
| | H | L | C | |
| ¼ | 5.00 | 2.09 | .47 | 1.50 |
| | (125) | (53) | (11) | (.68) |
| ⅜ | 5.00 | 2.09 | .47 | 1.50 |
| | (125) | (53) | (11) | (.68) |
| ½ | 5.00 | 2.09 | .47 | 1.50 |
| | (125) | (53) | (11) | (.68) |
| ¾ | 6.22 | 2.52 | .50 | 2.0 |
| | (160) | (63) | (12.7) | (.90) |
| 1 | 7.50 | 2.63 | .63 | 3.0 |
| | (190) | (67) | (16) | (1.36) |
| 1¼ | 9.00 | 2.91 | .70 | 5.0 |
| | (228) | (73) | (18) | (2.26) |
| 1½ | 9.14 | 3.14 | .75 | 6.5 |
| | (232) | (79) | (19) | (2.94) |
| 2 | 11.58 | 3.89 | .75 | 10.0 |
| | (293) | (99) | (19) | (4.53) |
| 2½ | 12.88 | 4.59 | .91 | 16.0 |
| | (327) | (116) | (23) | (7.25) |
| 3 | 14.77 | 4.92 | .91 | 24.0 |
| | (375) | (124) | (23) | (10.8) |
| 4 | 19.30 | 5.93 | .98 | 48.0 |
| | (490) | (150) | (24) | (21.7) |

Class 125 • U-Bolt Bonnet • Rising Stem • All Iron • Flanged

488 1/2 Gate Valve

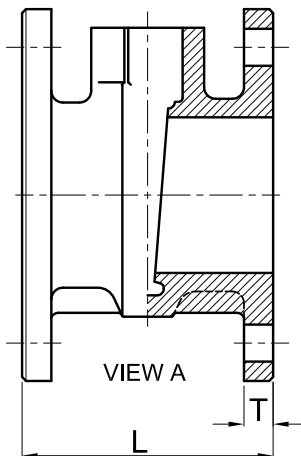
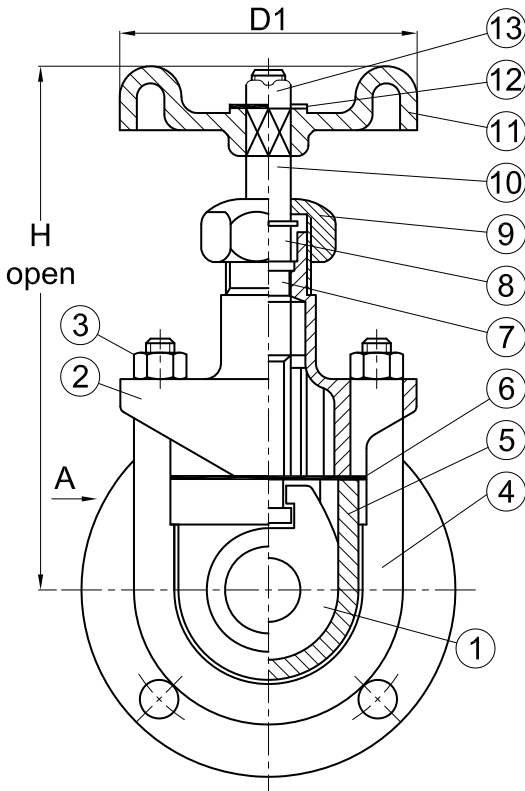

| Size | Pressure Rating |
|---------|-------------------------|
| 1 - 2" | 225 PSI WOG (Non-Shock) |
| 2½ - 4" | 175 PSI WOG (Non-Shock) |

Materials of Construction

| No. | Description | Material | ASTM |
|-----|-------------|----------------------------------|------------|
| 1 | Disc | Ductile Iron | A536 |
| 2 | Bonnet | Ductile Iron | A536 |
| 3 | Nut | Steel ASTM | A307 Gr. A |
| 4 | "U"-Bolt | Steel ASTM | A307 Gr. A |
| 5 | Body | Ductile Iron | A536 |
| 6 | Gasket | Aramid Fiber with Nitrile Binder | |
| 7 | Packing | Die-formed Compressed Graphite | |
| 8 | Gland | Stainless Steel | A276-410 |
| 9 | Packing Nut | Ductile Iron | A536 |
| 10 | Stem | Stainless Steel | A276-410 |
| 11 | Handwheel | Cast Iron | A126 Gr. B |
| 12 | Name Plate | Aluminum | |
| 13 | Wheel Nut | Steel | A307 Gr. A |

See page 5 for Pressure Temperature Ratings

Industry Standards

MSS SP-70, Type 1

ASME B16.42

Dimensions and Weights

Inches (millimeters) - Pounds (kilograms)

| Valve Size | Dimensions | | | | WT |
|------------|------------|-------|-------|------|--------|
| | H | L | D1 | T | |
| 1 | 7.50 | 3.19 | 2.95 | .32 | 6.0 |
| | (190) | (81) | (75) | (8) | (2.7) |
| 1½ | 9.14 | 3.74 | 3.75 | .32 | 11.0 |
| | (232) | (95) | (95) | (8) | (5) |
| 2 | 11.58 | 4.25 | 3.98 | .32 | 16.0 |
| | (293) | (108) | (101) | (8) | (7.3) |
| 2½ | 12.88 | 4.94 | 4.75 | .32 | 24.0 |
| | (327) | (125) | (121) | (8) | (11) |
| 3 | 14.77 | 5.06 | 6.00 | .37 | 34.0 |
| | (375) | (129) | (152) | (9) | (15.4) |
| 4 | 19.30 | 6.75 | 9.00 | .50 | 62.0 |
| | (490) | (171) | (229) | (13) | (28.1) |

Class 150 • U-Bolt Bonnet • Rising Stem • Bronze Trim • Threaded

490 Gate Valve

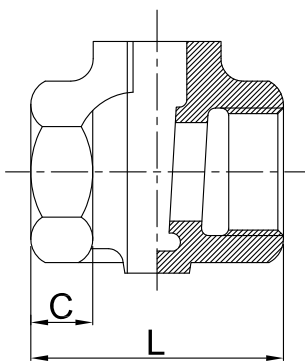
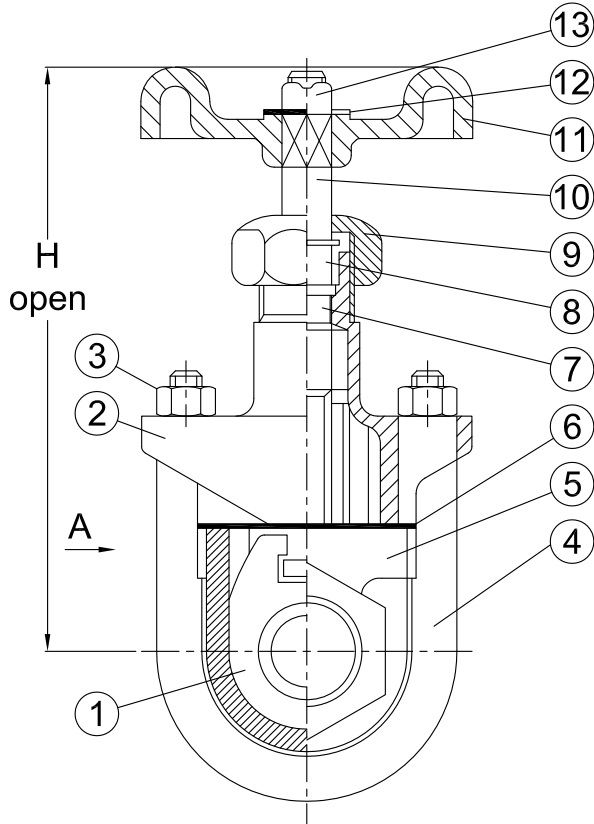

VIEW A

| Size | Pressure Rating | |
|------------|-----------------|-------------------------|
| | 150 PSI WSP | 225 PSI WOG (Non-Shock) |
| 1/4 - 2" | 150 PSI WSP | 225 PSI WOG (Non-Shock) |
| 2 1/2 - 4" | 125 PSI WSP | 175 PSI WOG (Non-Shock) |

Materials of Construction

| No. | Description | Material | ASTM |
|-----|-------------|----------------------------------|------------|
| 1 | Disc | Cast Bronze | B62 |
| 2 | Bonnet | Ductile Iron | A536 |
| 3 | Nut | Steel ASTM | A307 Gr. A |
| 4 | "U"-Bolt | Steel ASTM | A307 Gr. A |
| 5 | Body | Ductile Iron | A536 |
| 6 | Gasket | Aramid Fiber with Nitrile Binder | |
| 7 | Packing | Die-formed Compressed Graphite | |
| 8 | Gland | Brass | B16 |
| 9 | Packing Nut | Ductile Iron | A536 |
| 10 | Stem | Brass | B16 |
| 11 | Handwheel | Cast Iron | A126 Gr. B |
| 12 | Name Plate | Aluminum | |
| 13 | Wheel Nut | Steel | A307 Gr. A |

See page 5 for Pressure Temperature Ratings

Industry Standards

| |
|-------------------|
| MSS SP-70, Type 1 |
| ASME B16.42 |

Dimensions and Weights

Inches (millimeters) - Pounds (kilograms)

| Valve Size | Dimensions | | | WT |
|------------|------------|-------|--------|--------|
| | H | L | C | |
| 1/4 | 5.00 | 2.09 | .47 | 1.50 |
| | (125) | (53) | (11) | (.68) |
| 3/8 | 5.00 | 2.09 | .47 | 1.50 |
| | (125) | (53) | (11) | (.68) |
| 1/2 | 5.00 | 2.09 | .47 | 1.50 |
| | (125) | (53) | (11) | (.68) |
| 3/4 | 6.22 | 2.52 | .51 | 2.0 |
| | (160) | (63) | (12.7) | (.90) |
| 1 | 7.50 | 2.64 | .63 | 3.0 |
| | (190) | (67) | (16) | (1.36) |
| 1 1/4 | 9.00 | 2.91 | .70 | 5.0 |
| | (228) | (73) | (18) | (2.26) |
| 1 1/2 | 9.14 | 3.15 | .75 | 6.5 |
| | (232) | (79) | (19) | (2.94) |
| 2 | 11.58 | 3.90 | .75 | 10.0 |
| | (293) | (99) | (19) | (4.53) |
| 2 1/2 | 12.88 | 4.60 | .90 | 16.0 |
| | (327) | (116) | (23) | (7.25) |
| 3 | 14.77 | 4.92 | .90 | 24.0 |
| | (375) | (124) | (23) | (10.8) |
| 4 | 19.30 | 5.94 | .98 | 48.0 |
| | (490) | (150) | (24) | (21.7) |

Class 250 • Bolted Bonnet • N-R Stem • Bronze Trim • Flanged

3E Gate Valve

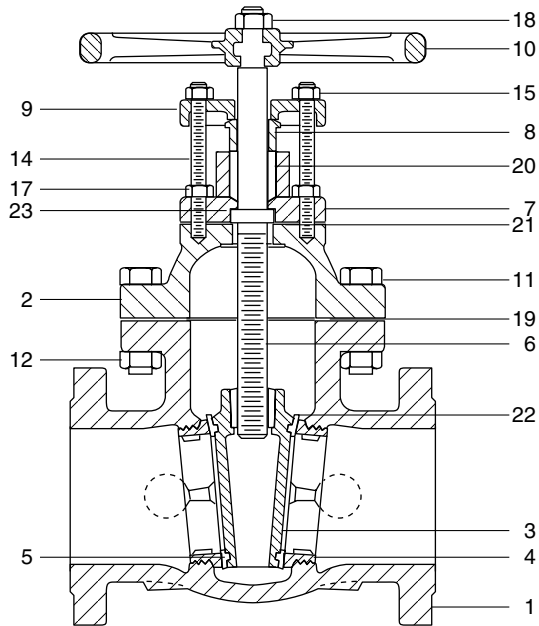

Industry Standards

MSS SP-70, Type 1

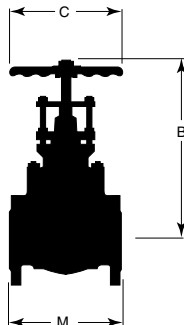

Materials of Construction

| No. | Description | Material | ASTM |
|-----|----------------------------|--|-------------------|
| 1 | Body | Cast Iron | A126 Class B |
| 2 | Bonnet | Cast Iron | A126 Class B |
| 3 | Disc | Bronze (2" - 4") | B584 C84400 |
| | | Cast Iron (6" - 12") | A126 Class B |
| 4 | Seat Ring | Bronze | B584 C84400 |
| 5 | Disc Ring | Bronze (6" - 12") | B584 C84400 |
| 6 | Stem | Manganese Bronze (2" - 8") | B584 C86400 |
| | | Naval Brass (10") | B21 C48500 |
| | | Manganese Bronze (12") | B138 67500 |
| 7 | Stuffing Box | Ductile Iron (2" - 4") | A536 Gr. 65-45-12 |
| | | Cast Iron (6" - 12") | A126 Class B |
| 8 | Gland | Ductile Iron (2" - 4") | A536 Gr. 65-45-12 |
| | | Bronze (6" - 12") | B584 C84400 |
| 9 | Gland Flange | Ductile Iron (6" - 12") | A536 Gr. 65-45-12 |
| 10 | Handwheel | Ductile Iron | A536 Gr. 65-45-12 |
| 11 | Bonnet Bolts | Carbon Steel | A307 Gr. B |
| 12 | Bonnet Bolt Nuts | Carbon Steel | A563 Gr. A |
| 13 | Stuffing Box Bolts* | Carbon Steel | A307 Gr. B |
| 14 | Gland Studs | Carbon Steel (2 1/2" - 6") | A108 |
| | | Carbon Steel (2", 8" - 12") | A307 Gr. B |
| 15 | Gland Stud or Bolt Nuts | Steel Zinc-Plated | A563 Gr. A |
| 16 | Stuffing Box Studs* | Carbon Steel | A108 |
| 17 | Stuff Box Stud - Bolt Nuts | Carbon Steel | A563 Gr. A |
| 18 | Handwheel Nut | Carbon Steel | A563 Gr. A |
| 19 | Bonnet Gasket | Aramid Fibers with SBR Binder | |
| 20 | Packing | Braided Flexible Graphite with Corrosion Inhibitor | |
| 21 | Stuffing Box Gasket | Aramid Fibers with SBR Binder | |
| 22 | Disc Bushing | Bronze | B21 C48200 |
| 23 | Identification Plate | Aluminum | |

* Not shown

See page 5 for Pressure Temperature Ratings

Dimensions and Weights Inches (millimeters) - Pounds (kilograms)

| Valve Size | Dimensions | | | WT |
|------------|------------|-------|-------|-------|
| | B | C | M | |
| 2 | 11.94 | 8.00 | 8.50 | 47 |
| | (303) | (203) | (216) | (21) |
| 2 1/2 | 12.94 | 8.00 | 9.50 | 84 |
| | (328) | (203) | (241) | (38) |
| 3 | 14.50 | 10.00 | 11.12 | 113 |
| | (368) | (254) | (282) | (51) |
| 4 | 17.38 | 12.00 | 12.00 | 175 |
| | (441) | (305) | (305) | (79) |
| 6 | 23.00 | 16.00 | 15.88 | 335 |
| | (584) | (406) | (403) | (151) |
| 8 | 30.75 | 20.00 | 16.50 | 545 |
| | (781) | (508) | (419) | (246) |
| 10 | 36.00 | 22.00 | 18.00 | 854 |
| | (914) | (559) | (457) | (385) |
| 12 | 39.75 | 24.00 | 19.75 | 1250 |
| | (1010) | (610) | (502) | (563) |

Class 250 • Bolted Bonnet • OS&Y • Bronze Trim • Flanged

7 1/2E Gate Valve

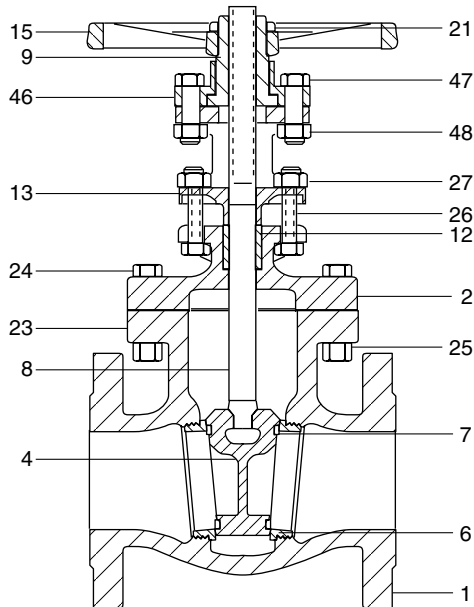

Industry Standards
MSS SP-70, Type 1

Materials of Construction

| No. | Description | Material | ASTM |
|-----|--------------------|--|----------------------------|
| 1 | Body | Cast Iron | A126 Class B |
| 2 | Bonnet | Cast Iron | A126 Class B |
| 4 | Disc | Bronze (2" - 3") | B584 C84400 |
| | | Cast Iron (4" - 12") | A126 Class B |
| 6 | Seat Ring | Bronze | B584 C84400 |
| 7 | Disc Ring | Bronze (4" - 12") | B584 C84400 |
| 8 | Stem | Manganese Bronze (2" - 4", 6" - 8") | B584 C86400 |
| | | Naval Brass (5", 10", 12") | B21 C48500 |
| 9 | Yoke Sleeve | Manganese Bronze | B584 C86400 |
| 12 | Packing | Braided Flexible Graphite with Corrosion Inhibitor | |
| 13 | Gland | Ductile Iron (2" - 4", 6") | A536 Gr. 65-45-12 |
| | | Bronze (8" - 12") | B584 C84400 |
| 14 | Gland Flange* | Carbon Steel (5") | A307 Gr. B |
| | | Ductile Iron (8" - 12") | A536 Gr. 65-45-12 |
| 15 | Handwheel | Ductile Iron | A536 Gr. 65-45-12 |
| 21 | Handwheel Nut | Sintered Nickel Steel (2" - 6") | B484 Gr. 2 Class B Type II |
| | | Ductile Iron (8" - 12") | A536 Gr. 65-45-12 |
| 23 | Bonnet Gasket | Aramid Fibers with SBR Binder | |
| 24 | Bonnet Bolt | Carbon Steel | A307 Gr. B |
| 25 | Bonnet Bolt Nut | Carbon Steel | A563 Gr. A |
| 26 | Gland Bolt | Carbon Steel (2" - 4", 6" - 8") | A307 Gr. B |
| | | Carbon Steel (5", 10", 12") | A307 Gr. B |
| 27 | Gland Bolt Nut | Carbon Steel Zinc-Plated | A563 Gr. A |
| 46 | Yoke Cap | Ductile Iron (2" - 4", 6") | A536 Gr. 65-45-12 |
| | | Cast Iron (8") | A126 Class B |
| 47 | Yoke Cap Bolt | Carbon Steel | A307 Gr. B |
| 48 | Yoke Cap Bolt Nut | Carbon Steel | A563 Gr. A |
| 51 | Yoke Hub Bolt* | Carbon Steel (5", 10", 12") | |
| 52 | Yoke Hub Bolt Nut* | Carbon Steel (5", 10", 12") | |
| 53 | Yoke Pad Bolt* | Carbon Steel (5", 10", 12") | |

* Not shown

See page 5 for Pressure Temperature Ratings

Dimensions and Weights
Inches (millimeters) - Pounds (kilograms)

| Valve Size | Dimensions | | | WT |
|------------|------------|-------|-------|-------|
| | B | C | M | |
| 2 | 15.06 | 8.00 | 8.50 | 54 |
| | (382) | (203) | (216) | (24) |
| 2 1/2 | 16.69 | 8.00 | 9.50 | 80 |
| | (424) | (203) | (241) | (36) |
| 3 | 18.75 | 10.00 | 11.12 | 114 |
| | (476) | (254) | (282) | (52) |
| 4 | 23.44 | 12.00 | 12.00 | 174 |
| | (595) | (305) | (305) | (79) |
| 5 | 24.00 | 14.00 | 15.00 | 280 |
| | 609 | 356 | 381 | 127 |
| 6 | 31.75 | 16.00 | 15.88 | 332 |
| | (806) | (406) | (403) | (151) |
| 8 | 39.88 | 18.00 | 16.50 | 600 |
| | (1,012) | (457) | (419) | (270) |
| 10 | 41.75 | 22.00 | 18.00 | 920 |
| | (1060) | (559) | (457) | (417) |
| 12 | 47.00 | 24.00 | 19.75 | 1400 |
| | (1193) | (610) | (502) | (635) |

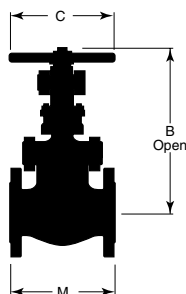

Class 125 • Bolted Bonnet • OS&Y • Bronze Trim • Flanged

351 Globe Valve

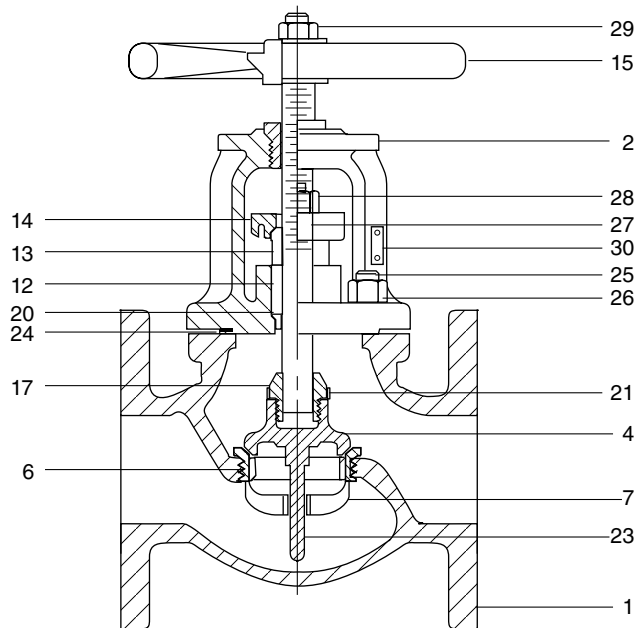

Materials of Construction

| No. | Description | Material | ASTM |
|-----|----------------------|--|-------------------|
| 1 | Body | Cast Iron | A126 Class B |
| 2 | Bonnet | Cast Iron | A126 Class B |
| 4 | Disc | Bronze (2" - 6") | B584 C84400 |
| | | Cast Iron (8" - 10") | A126 Class B |
| 6 | Body Seat Ring | Bronze | B584 C84400 |
| 7 | Disc Seat Ring | Bronze (8" & 10") | B584 C84400 |
| 8 | Stem | Manganese Bronze | B584 C86400 |
| 9 | Yoke Bushing | Manganese Bronze | B584 C86400 |
| 12 | Packing | Braided Flexible Graphite with Corrosion Inhibitor | |
| 13 | Gland | Brass (2" - 4") | B16 C36000 |
| | | Bronze (5" - 10") | B584 C84400 |
| 14 | Gland Flange | Ductile Iron | A536 Gr. 65-45-12 |
| 15 | Handwheel | Ductile Iron | A536 Gr. 65-45-12 |
| 17 | Disc Stem Ring | Bronze | B584 C84400 |
| 20 | Stem Hole Bushing | Brass | B16 C36000 |
| 21 | Locking Device | 18-8 SST Sheet (2" - 6") | A167 |
| 22 | Disc Guide Stem* | Brass (8" & 10") | B16 C36000 |
| 23 | Disc Guide Stem Pin | Brass (8" & 10") | B16 C36000 |
| 24 | Bonnet Gasket | Aramid Fibers with SBR Binder | |
| 25 | Bonnet Studs | Steel | A108 |
| 26 | Bonnet Stud Nuts | Steel | A563 Gr. A |
| 27 | Gland Studs | Naval Brass | B21 C48200 |
| 28 | Gland Stud Nuts | Brass | B16 C36000 |
| 29 | Handwheel Nut | Steel - Phos. Coated | A563 Gr. A |
| 30 | Identification Plate | Aluminum | |

* Not shown

See page 5 for Pressure Temperature Ratings

Industry Standards

MSS SP-85, Type 1

Dimensions and Weights

Inches (millimeters) - Pounds (kilograms)

| Valve Size | Dimensions | | | WT |
|------------|------------|-------|-------|-------|
| | B | C | M | |
| 2 | 11.12 | 8.00 | 8.00 | 35 |
| | (282) | (203) | (203) | (15) |
| 2 ½ | 11.50 | 8.00 | 8.50 | 40 |
| | (292) | (203) | (216) | (18) |
| 3 | 13.25 | 9.00 | 9.50 | 57 |
| | (337) | (229) | (241) | (26) |
| 4 | 15.50 | 10.00 | 11.50 | 95 |
| | (394) | (254) | (292) | (43) |
| 5 | 17.50 | 10.00 | 13.00 | 126 |
| | (445) | (254) | (330) | (57) |
| 6 | 19.50 | 12.00 | 14.00 | 176 |
| | (495) | (305) | (356) | (80) |
| 8 | 25.00 | 16.00 | 19.50 | 344 |
| | (635) | (406) | (495) | (156) |
| 10 | 30.50 | 18.00 | 24.50 | 570 |
| | (775) | (457) | (622) | (259) |

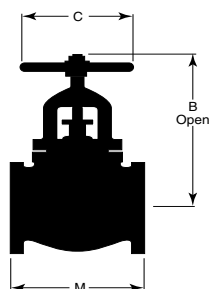

Class 125 • Bolted Bonnet • OS&Y • Bronze Trim • Flanged

353 Globe Valve

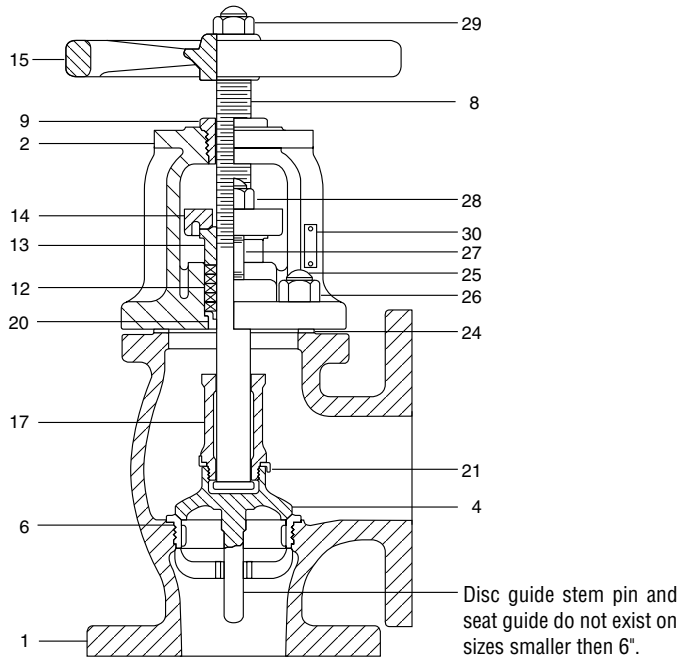

Materials of Construction

| No. | Description | Material | ASTM |
|-----|----------------------|--|-------------------|
| 1 | Body | Cast Iron | A126 Class B |
| 2 | Bonnet | Cast Iron | A126 Class B |
| 4 | Disc | Bronze | B584 C84400 |
| 6 | Seat Ring | Bronze | B584 C84400 |
| 8 | Stem | Manganese Bronze | B584 C86400 |
| 9 | Yoke Bushing | Manganese Bronze | B584 C86400 |
| 12 | Packing | Braided Flexible Graphite with Corrosion Inhibitor | |
| 13 | Gland | Brass (2" - 4") | B16 C36000 |
| | | Bronze (6") | B584 C84400 |
| 14 | Gland Flange | Ductile Iron | A536 Gr. 65-45-12 |
| 15 | Handwheel | Ductile Iron | A536 Gr. 65-45-12 |
| 17 | Disc Stem Ring | Bronze | B584 C84400 |
| 20 | Stem Hole Bushing | Brass | B16 C36000 |
| 21 | Locking Device | 18-8 Stainless Steel | A167 |
| 24 | Bonnet Gasket | Aramid Fibers with SBR Binder | |
| 25 | Bonnet Studs | Carbon Steel | A108 |
| 26 | Bonnet Stud Nuts | Carbon Steel | A563 Gr. A |
| 27 | Gland Studs | Naval Brass | B21 C48200 |
| 28 | Gland Stud Nuts | Brass | B16 C36000 |
| 29 | Handwheel Nut | Carbon Steel | A563 Gr. A |
| 30 | Identification Plate | Aluminum | |

* Not shown
See page 5 for Pressure Temperature Ratings

Industry Standards

MSS SP-85, Type 2

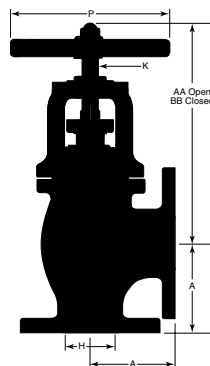

Dimensions and Weights

Inches (millimeters) - Pounds (kilograms)

| Valve Size | Dimensions | | | | | | WT |
|------------|------------|-------|------|-------|-------|-------|------|
| | A | H | K | P | AA | BB | |
| 2 | 4.00 | 2.00 | 0.88 | 8.00 | 11.00 | 10.25 | 32 |
| | (102) | (51) | (22) | (203) | (279) | (260) | (15) |
| 2 ½ | 4.25 | 2.50 | 0.88 | 8.00 | 11.50 | 10.50 | 38 |
| | (108) | (64) | (22) | (203) | (292) | (267) | (17) |
| 3 | 4.75 | 3.00 | 1.00 | 9.00 | 12.75 | 11.75 | 54 |
| | (121) | (76) | (25) | (229) | (324) | (299) | (25) |
| 4 | 5.75 | 4.00 | 1.12 | 10.00 | 15.00 | 13.75 | 88 |
| | (146) | (102) | (29) | (254) | (381) | (349) | (40) |
| 6 | 7.00 | 6.00 | 1.25 | 12.00 | 19.50 | 17.75 | 158 |
| | (178) | (152) | (32) | (305) | (495) | (451) | (72) |

Class 250 • Bolted Bonnet • OS&Y • Bronze Trim • Flanged

21E Globe Valve

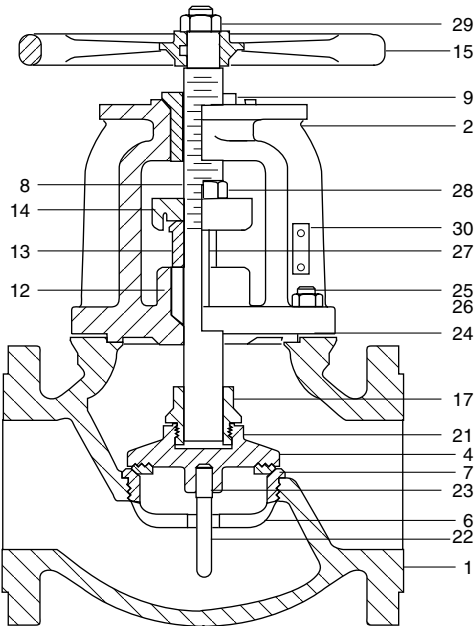

Materials of Construction

| No. | Description | Material | ASTM |
|-----|----------------------------|--|--------------|
| 1 | Body | Cast Iron | A126 Class B |
| 2 | Bonnet | Cast Iron | A126 Class B |
| 4 | Disc | Bronze (2" - 3") | B61 |
| | | Cast Iron (4" - 8") | A126 Class B |
| 6 | Body Seat Ring | Bronze | B61 |
| 7 | Disc Seat Ring | Bronze (6" - 8") | B61 |
| 8 | Stem | Manganese Bronze | B584 C86400 |
| 9 | Yoke Bushing | Manganese Bronze | B584 C86400 |
| 12 | Packing | Braided Flexible Graphite with Corrosion Inhibitor | |
| 13 | Gland | Bronze | B62 |
| 14 | Gland Flange | Steel (2", 3" & 6") | A181 |
| | | Ductile Iron | A536 |
| 15 | Handwheel | Ductile Iron | A536 |
| 17 | Disc Stem Ring | Bronze | B62 |
| 21 | Locking Device | 18-8 SST Sheet (2" - 5") | A167 |
| 22 | Disc Guide Stem | Steel (6" - 8") | A108 |
| 23 | Disc Guide Stem Pin | Steel (6" - 8") | B108 |
| 24 | Gasket | Aramid Fibers with SBR Binder | |
| 25 | Bonnet Studs | Steel | A108 |
| 26 | Bonnet Stud Nuts | Steel | A563 Gr. A |
| 27 | Gland Studs | Steel - Phos. Coated | A108 |
| 28 | Gland Stud Nuts | Steel - Phos. Coated | A563 Gr. A |
| 29 | Handwheel Nut | Steel - Phos. Coated | A563 Gr. A |
| 30 | Identification Plate | Aluminum | |
| 31 | Disc - Disc Stem Ring Pin* | Steel | |

* Not shown

See page 5 for Pressure Temperature Ratings

Industry Standards

MSS SP-85, Type 1

Dimensions and Weights

Inches (millimeters) - Pounds (kilograms)

| Valve Size | Dimensions | | | WT |
|------------|------------|-------|-------|-------|
| | B | C | M | |
| 2 | 13.75 | 9.00 | 10.50 | 62 |
| | (349) | (229) | (267) | (28) |
| 2 ½ | 14.75 | 10.00 | 11.50 | 82 |
| | (375) | (254) | (292) | (37) |
| 3 | 16.50 | 10.00 | 12.50 | 118 |
| | (419) | (254) | (318) | (54) |
| 4 | 18.50 | 12.00 | 14.00 | 167 |
| | (470) | (305) | (356) | (76) |
| 6 | 23.25 | 16.00 | 17.50 | 320 |
| | (591) | (406) | (445) | (145) |
| 8 | 28.50 | 20.00 | 21.00 | 570 |
| | (724) | (508) | (533) | (259) |

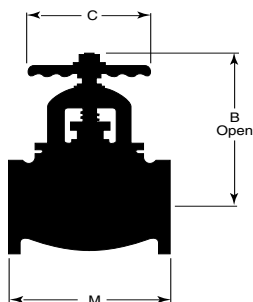

Class 250 • Bolted Bonnet • OS&Y • Bronze Trim • Flanged

28E Stop Check Valve

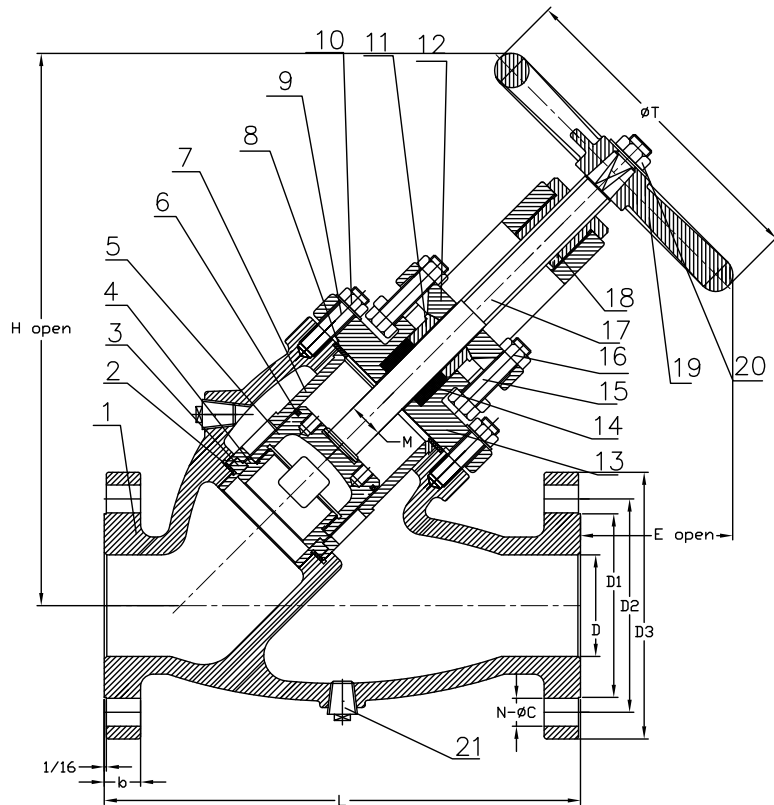

Materials of Construction

| No. | Description | Material | ASTM |
|-----|------------------|--------------------------------|---------|
| 1 | Body | Ductile Iron | A536 |
| 2 | Body Seat Gasket | Graphite | |
| 3 | Body Seat Ring | Cast Bronze | B62 |
| 4 | Disc Seal | Cast Bronze | B62 |
| 5 | Disc | Ductile Iron | A536 |
| 6 | Piston Ring | Alloy Cast Iron | |
| 7 | Disc Guide | Ductile Iron | A536 |
| 8 | Body Gasket | Graphite | |
| 9 | Bolts | Steel | A193 B7 |
| 10 | Nuts | Steel | A194 2H |
| 11 | Packing Gland | Cast Brass | B62 |
| 12 | Gland Follower | Ductile Iron | A536 |
| 13 | Bonnet | Ductile Iron | A536 |
| 14 | Packing | Die-formed Compressed Graphite | |
| 15 | Bolts | Steel | A193 B7 |
| 16 | Nuts | Steel | A194 2H |
| 17 | Stem | Stainless Steel | 410 |
| 18 | Stem Nut | Cast Brass | B62 |
| 19 | Handwheel | Cast Iron | A126 B |
| 20 | Nut | Steel | A194 2H |
| 21 | Drain Plug | Stainless Steel | 304 |

See pages 23-26 for sizing and other Technical Data

NOTE: Contact your CRANE® representative if you wish to have basic flow calculations performed by CRANE® to advise the possible sizes appropriate for your application.

Dimensions and Weights

Inches (millimeters) - Pounds (kilograms)

Features:

- Valve designed for steam applications that operate between 100 and 250 psig.
- The Stop-Check feature of this valve requires a minimum of 50 psi pressure differential between piping system and boiler to operate properly.

| Drain Plug Sizing Chart | |
|-------------------------|---------------|
| 2 1/2" - 6" Valves | 1/2" NPT Plug |
| 6" - 10" Valves | 3/4" NPT Plug |

| Valve Size | Dimensions | | | | | | | | | | WT | |
|------------|----------------|----------------|----------------|----------------|----------------|--------------|-----------|--------------|----------------|----------------|----------------|----------------|
| | D | D1 | D2 | D3 | L | b | N - øC | M | H (Open) | E (Open) | | T |
| 2 1/2 | 2.50 (64) | 4.94 (125) | 5.86 (149) | 7.50 (191) | 13.00 (330) | 1.00 (25) | 8 - ø7/8 | 1.13 (29) | 15.75 (400) | 5.00 (127) | 10.00 (254) | 103 (47) |
| | 3.00 (76) | 5.69 (145) | 6.63 (168) | 8.25 (210) | 14.75 (375) | 1.13 (29) | | 1.13 (29) | 18.69 (474) | 6.29 (159) | 10.00 (254) | 140 (64) |
| 4 | 4.00 (102) | 6.31 (160) | 7.86 (200) | 10.00 (254) | 17.00 (432) | 1.25 (32) | 8 - ø7/8 | 1.25 (32) | 21.47 (545) | 7.61 (193) | 10.13 (257) | 226 (103) |
| | 5.00 (127) | 8.31 (211) | 9.25 (235) | 11.00 (279) | 19.00 (483) | 1.38 (35) | | 1.50 (38) | 24.46 (621) | 9.38 (238) | 14.00 (355) | 307 (139) |
| 6 | 6.00 (152) | 9.69 (246) | 10.63 (270) | 12.50 (318) | 21.50 (546) | 1.44 (37) | 12 - ø7/8 | 1.50 (38) | 28.82 (732) | 11.26 (286) | 17.75 (450) | 420 (191) |
| | 8.00 (203) | 11.94 (303) | 13.00 (330) | 15.00 (381) | 26.00 (660) | 1.63 (41) | | 12 - ø1 | 1.63 (41) | 35.62 (904) | 15.19 (385) | 20.00 (508) |
| 10 | 10.00 (254) | 14.06 (357) | 15.25 (387) | 17.50 (445) | 30.00 (762) | 1.88 (48) | - | | 1.75 (44) | - | - | - |

30E Angle Stop Check Valve

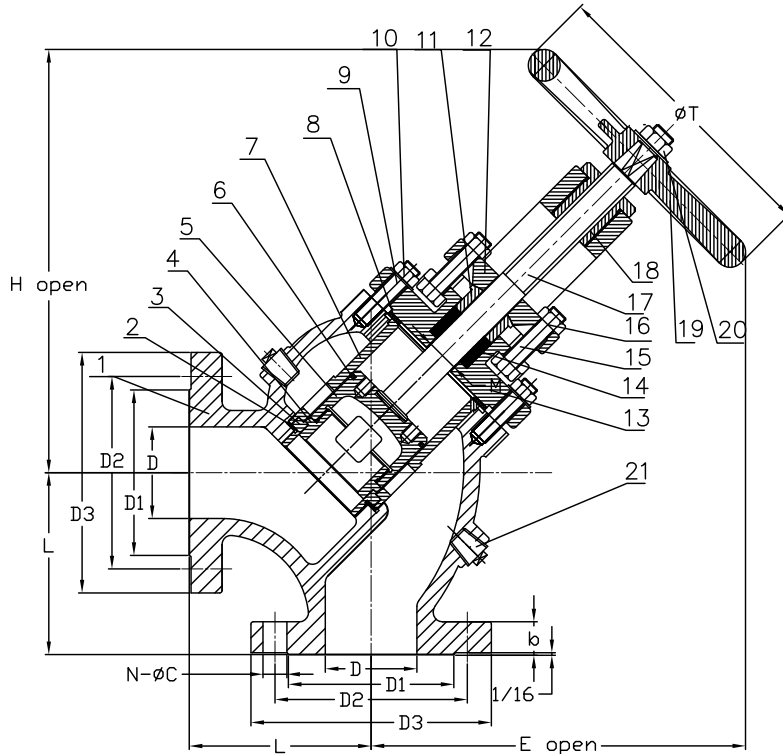

Materials of Construction

| No. | Description | Material | ASTM |
|-----|------------------|--------------------------------|---------|
| 1 | Body | Ductile Iron | A536 |
| 2 | Body Seat Gasket | Graphite | |
| 3 | Body Seat Ring | Cast Bronze | B62 |
| 4 | Disc Seal | Cast Bronze | B62 |
| 5 | Disc | Ductile Iron | A536 |
| 6 | Piston Ring | Alloy Cast Iron | |
| 7 | Disc Guide | Ductile Iron | A536 |
| 8 | Body Gasket | Graphite | |
| 9 | Bolts | Steel | A193 B7 |
| 10 | Nuts | Steel | A194 2H |
| 11 | Packing Gland | Cast Brass | B62 |
| 12 | Gland Follower | Ductile Iron | A536 |
| 13 | Bonnet | Ductile Iron | A536 |
| 14 | Packing | Die-formed Compressed Graphite | |
| 15 | Bolts | Steel | A193 B7 |
| 16 | Nuts | Steel | A194 2H |
| 17 | Stem | Stainless Steel | 410 |
| 18 | Stem Nut | Cast Brass | B62 |
| 19 | Handwheel | Cast Iron | A126 B |
| 20 | Nut | Steel | A194 2H |
| 21 | Drain Plug | Stainless Steel | 304 |

See pages 23 - 26 for sizing and other Technical Data

NOTE: Contact your CRANE® representative if you wish to have basic flow calculations performed by CRANE® to advise the possible sizes appropriate for your application.

Features:

- Valve designed for steam applications that operate between 100 and 250 psig.
- The Stop-Check feature of this valve requires a minimum of 50 psi pressure differential between piping system and boiler to operate properly.

| Drain Plug Sizing Chart | |
|-------------------------|---------------|
| 2 1/2" - 6" Valves | 1/2" NPT Plug |
| 6" - 10" Valves | 3/4" NPT Plug |

Dimensions and Weights

Inches (millimeters) - Pounds (kilograms)

| Valve Size | Dimensions | | | | | | | | | | WT | |
|------------|------------|-------|-------|-------|-------|------|-------------|------|----------|----------|-------|-------|
| | D | D1 | D2 | D3 | L | b | N - øC | M | H (Open) | E (Open) | | T |
| 2 1/2 | 2.50 | 4.94 | 5.86 | 7.50 | 5.75 | 1.00 | 8 - ø7/8 | 1.13 | 13.87 | 12.85 | 10.00 | 86 |
| | (64) | (125) | (149) | (191) | (146) | (25) | | (29) | (352) | (326) | (254) | (39) |
| 3 | 3.00 | 5.69 | 6.63 | 8.25 | 6.25 | 1.13 | 8 - ø7/8 | 1.13 | 16.00 | 14.37 | 10.00 | 123 |
| | (76) | (145) | (168) | (210) | (159) | (29) | | (29) | (406) | (364) | (254) | (55) |
| 4 | 4.00 | 6.31 | 7.86 | 10.00 | 7.00 | 1.25 | 8 - ø7/8 | 1.25 | 18.00 | 15.71 | 10.13 | 186 |
| | (102) | (160) | (200) | (254) | (178) | (32) | | (32) | (457) | (399) | (257) | (84) |
| 5 | 5.00 | 8.31 | 9.25 | 11.00 | 7.88 | 1.38 | 8 - ø7/8 | 1.50 | 21.35 | 18.67 | 14.00 | 250 |
| | (127) | (211) | (235) | (279) | (200) | (35) | | (38) | (542) | (474) | (355) | (113) |
| 6 | 6.00 | 9.69 | 10.63 | 12.50 | 8.75 | 1.44 | 12 - ø7/8 | 1.50 | 24.76 | 21.93 | 17.75 | 340 |
| | (152) | (246) | (270) | (318) | (222) | (37) | | (38) | (628) | (557) | (450) | (154) |
| 8 | 8.00 | 11.94 | 13.00 | 15.00 | 10.50 | 1.63 | 12 - ø1 | 1.63 | 32.79 | 28.26 | 20.00 | 640 |
| | (203) | (303) | (330) | (381) | (267) | (41) | | (41) | (832) | (717) | (508) | (291) |
| 10 | 10.00 | 14.06 | 15.25 | 17.50 | 12.25 | 1.88 | 16 - ø1 1/8 | 1.75 | 33.98 | 29.25 | 20.00 | 1025 |
| | (254) | (357) | (387) | (445) | (311) | (48) | | (44) | (863) | (742) | (508) | (465) |

Technical Data Stop Check Valves

Selecting the Proper Size Determining Pressure Drop

Since stop-check valves have a floating disc member, it is important that the valve be sized to provide full disc lift under flow conditions prevailing during the major portion of the service life. If the valve is too large, the disc will float in a partially open position and may cause fluttering of the disc and rapid wear.

Conversely, if the valve is too small, pressure drop will be excessive. The chart on the following page is a graphic presentation of flow data determined by test. Its use offers a simple method of determining the best size stop-check valve, as well as the pressure drop under varying conditions of flow, without any computation.

How to Use the Chart Shown on the Following Page

Given: Steam Pressure-Temperature...250 psig 450°F
Flow Rate...Typical Daily Demand Curve

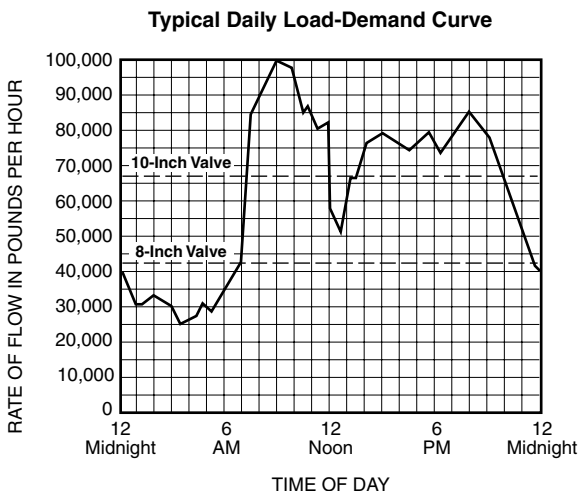

Find: Valve Catalog No. and the best size for above installation.

Solution:

1. Enter the Temperature chart at 450 °F. Move vertically upward to the curved line for 250 psi, then horizontally to the right to establish a point on the specific volume scale. From this point, draw a line through the flow rate being investigated (100,000 Lb/H) and establish a point on Index 1.

2. From that point, draw another line through the valve size, for example the 8-inch size, and establish a point on Index 2. Now move horizontally to the diagonal pressure drop line on the right side. Where these lines intersect, the pressure drop is 7.5 psi for the 8-inch, Class 250 globe valve and 8.5 psi for the 8-inch Class 250 angle valve.

Chart solutions resulting in a point on Index 2 that falls below the Line A-A for Class 250 valves indicate the disc will not be fully lifted under the flow conditions used. Operation under such conditions is not recommended but, at times, must be tolerated for short periods during the low loads.

3. Enter the chart where Line A-A intersects Index 2 for Class 250 valves. Move diagonally upward through the size being investigated (8-inch) and establish a second point on Index 1. From this point, extend a line to the specific volume established in Step 1 and at its intersection with the flow rate line, read 48,000 Lb/H as the minimum flow rate at which the disc will be in the fully lifted position. The pressure drop at this flow rate is 1.9 psi for globe and 2.1 psi for angle valves.

4. Repeat Steps 2 and 3 for other possible valve sizes, tabulate results, and make size selection on basis of pressure drop and duration of partial disc lift considerations.

| Valve Size (Inches) | Press drop @ Max.Min. Flow rate (100,000 #/Hr.), psi | | Flow Rate for Wide open valve #/Hr. |
|------------------------|--|-------|--|
| | Globe | Angle | |
| 6 | 20.5 | 22.5 | 26,500 |
| 8 | 7.5 | 8.5 | 48,000 |
| 10 | 3.3 | 3.6 | 68,000 |

Dotted lines on Demand Curve indicate minimum flow rates for wide open 8" and 10" valves.

5. The best choice for this example would be the 10" size because pressure drop is much lower and duration of partially lifted disc is only slightly greater than for the 8" size.

6. Pressure drop for any intermediate flow condition can be determined as outlined in Steps 1 and 2.

7. Valves require a minimum of 50 psi differential pressure to seat the valve.

Technical Data Y-Pattern Stop Check Valves

CRANE® Bolted Bonnet Stop-Check Valves Selecting the Proper Size – Determining Pressure Drop

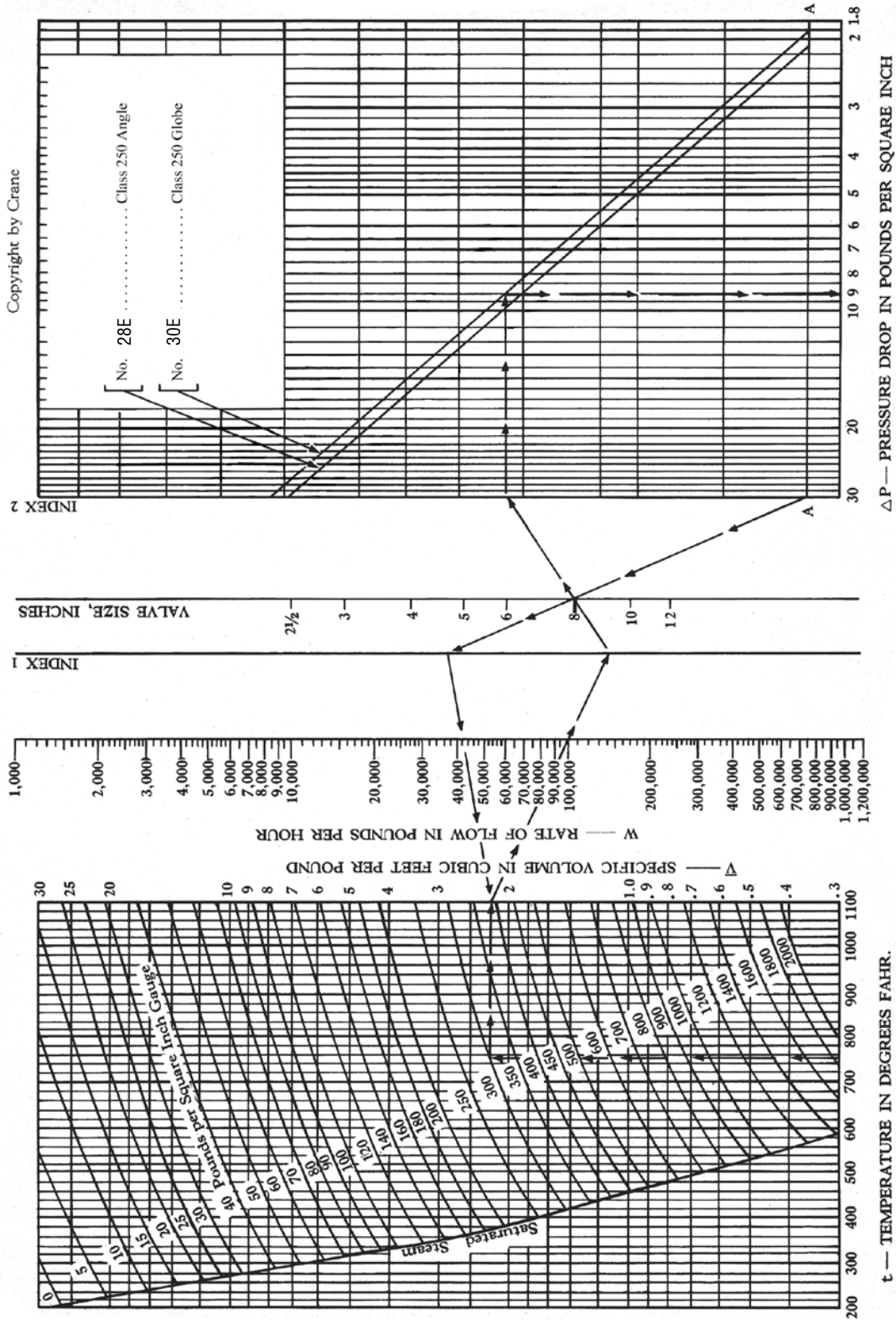

Stop Check Sizing Information

CRANE® STOP-CHECK VALVE SIZING INFORMATION REQUIRED
Figure 28E Straight Through Y-Pattern
Figure 30E Angle Y-Pattern

Minimum constant pressure of 100 psig required for valve to operate properly.
Systems below 100 psig will not be possible to size

Information required to properly size Stop-Check valves includes both minimum and maximum operating conditions.

Maximum Operating Conditions

Pressure: _____ psig Maximum
 Temperature: _____ °F
 Specific Volume: _____ cu. Ft/lbs (#a)
 Flow Rate: _____ lbs/hr. Maximum

Customer: _____
 Project: _____
 Date: _____
 Customer: _____
 Phone #: _____
 e-mail: _____

(#a) We can obtain specific volume from steam table when provided with the temperature and pressure.

Minimum Operating Conditions

Pressure: _____ psig Minimum
 Temperature: _____ °F
 Specific Volume: _____ cu. Ft/lbs (#a)
 Flow Rate: _____ lbs/hr. Minimum

(#a) We can obtain specific volume from steam table when provided with the temperature and pressure.

In addition, valve installation orientation should be considered as well as the overall system of operation. Please keep in mind that our stop-check valves are metal seated and are a safety valve to prevent backflow. Since they are metal seated there is some allowable leakage rate per API-598. A minimum of 50-60 psi pressure differential is required for this valve to properly operate.

In order to properly run sizing calculations we require the flow rate (lbs/Hr.) thru the individual units (both minimum and maximum flows) along with the temperatures and pressures, again both minimum and maximums.

Operating Conditions:

Are all the valves on one boiler, or are they on separate boilers? _____
 Are the boilers operated independently of each other, or are the units manifolded together to cycle between boilers?
 Are the idle boilers allowed to fully depressurize, or are they maintaining a temperature/pressure in the standby boilers?
 If so, what pressure/temperature is being maintained on standby and what is the operating system pressure?

As indicated in our literature, the CRANE® 28E can be operated in both a horizontal, and a vertical (upflow) line. The check valve feature should not be relied upon for primary shutoff.

The calculations are based upon temperatures, pressures, and flow rates provided. If there are significant fluctuations in any of these operating condition parameters than the units may not operate properly.

The reason we require information about stand-by mode on the boilers is because we have found that a significant number of end users have in the past several years changed their method of operation of multiple boilers. In the past the units would have been cycled between boilers and the non-active boiler allowed to totally de-pressurize and temperature normalize. More recently, we have seen a cycling program that keeps the stand-by unit with some temperature and with a significant pressure. When this method is used the stop-checks have a pressure on both sides of the piston/disc seal, causing the valves to not properly check.

Installation Recommendations

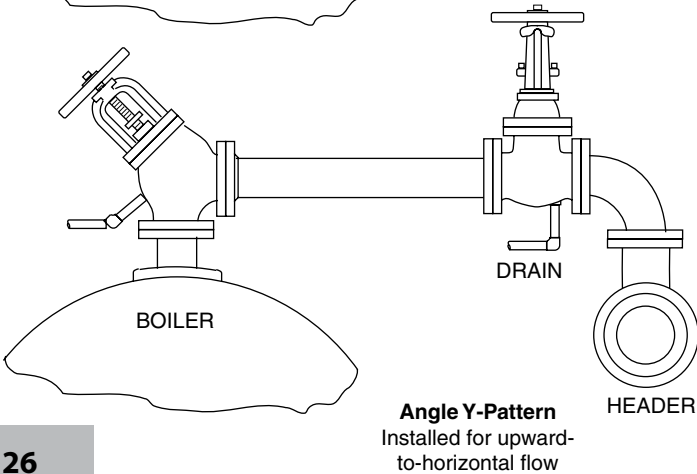
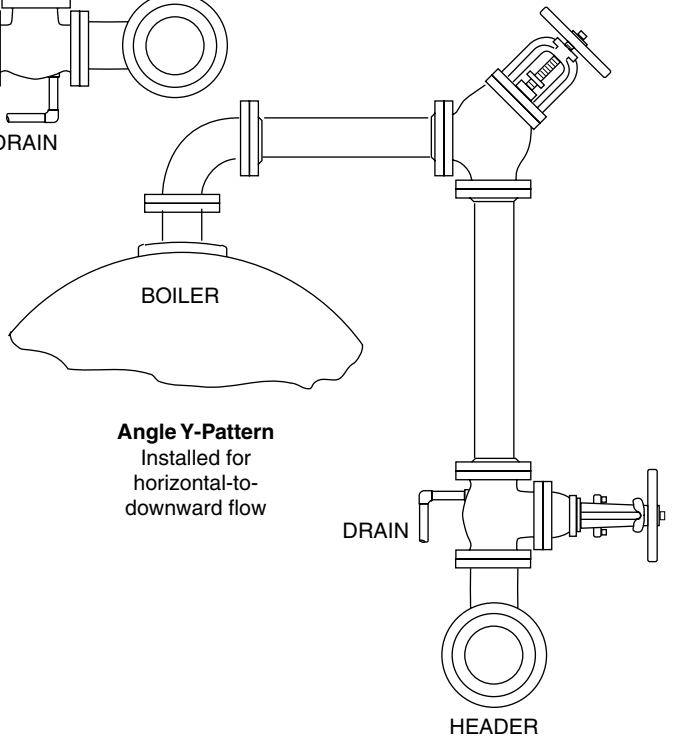
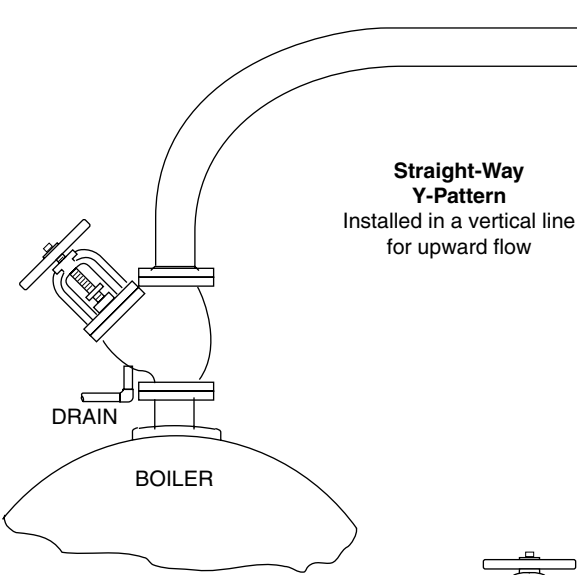
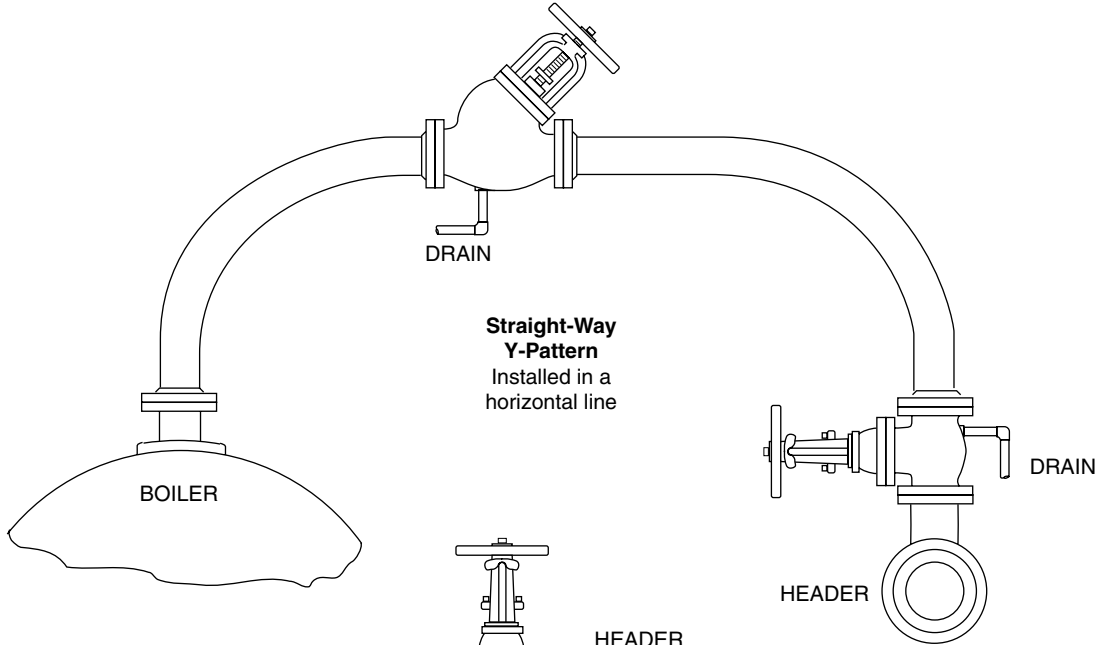

As shown in these diagrams, CRANE® Y-Pattern stop-check valves used in a boiler installation can be positioned for horizontal or upward flow. The proper method for draining both Y-pattern stop-check valves and isolation gate valves is shown for typical mounting positions. Tapped and plugged drain holes are furnished. For top efficiency, be sure the proper size valve is used.

Class 125 • Bolted Cap • Bronze Trim • Threaded Ends

372 Check Valve

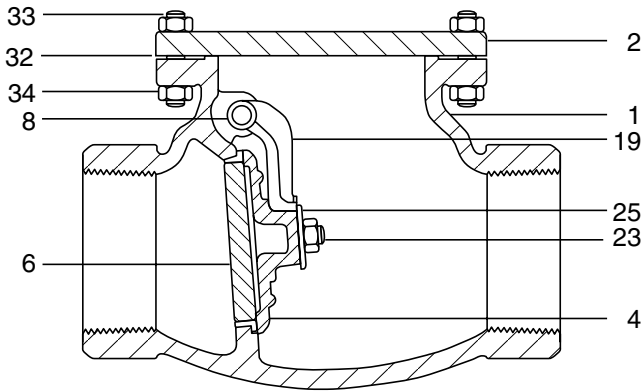

Materials of Construction

| No. | Description | Material | ASTM |
|-----|-----------------------|-------------------------------|--------------|
| 1 | Body | Cast Iron | A126 Class B |
| 2 | Cap | Cast Iron | A126 Class B |
| 4 | Disc | Bronze | B62 |
| 6 | Seat Ring | Bronze | B62 |
| 8 | Hinge Pin | Alum Silicon Bronze | B150 |
| 19 | Hinge | Bronze | B62 |
| 23 | Disc Nut | Brass | B16 |
| 24 | Side Plug* | Brass | B16 |
| 25 | Disc Washer | Brass | B36 |
| 28 | Hinge Pin Bushing* | Brass | B62 |
| 32 | Bonnet Gasket | Aramid Fibers with SBR Binder | |
| 33 | Cap Bolt | Carbon Steel | A307 Gr. B |
| 34 | Cap Bolt Nut | Carbon Steel | A563 Gr. A |
| 36 | Identification Plate* | Aluminum | |

* Not shown

See page 5 for Pressure Temperature Ratings

Industry Standards

MSS SP-71, Type 1

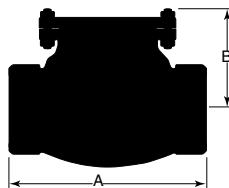

Dimensions and Weights

Inches (millimeters) - Pounds (kilograms)

| Valve Size | Dimensions | | WT |
|------------|------------|-------|------|
| | A | B | |
| 2 | 6.12 | 4.50 | 18 |
| | (155) | (114) | (8) |
| 2 ½ | 7.25 | 5.38 | 22 |
| | (184) | (137) | (10) |
| 3 | 8.00 | 5.88 | 29 |
| | (203) | (149) | (13) |
| 4 | 9.25 | 6.62 | 54 |
| | (235) | (168) | (25) |

Class 125 • Bolted Cap • Bronze Trim • Flanged Ends

373 Check Valve

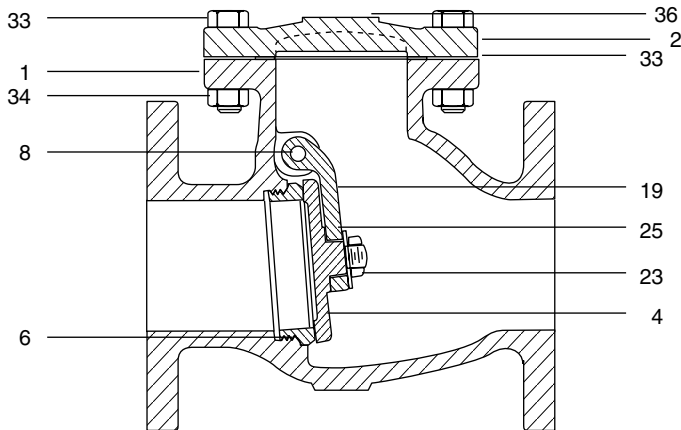

Dimensions and Weights Inches (millimeters) - Pounds (kilograms)

| Valve Size | Dimensions | | WT |
|------------|------------|--------|--------|
| | B | M | |
| 2 | 4.50 | 8.00 | 25 |
| | (114) | (203) | (11) |
| 2 ½ | 5.38 | 8.50 | 30 |
| | (137) | (216) | (14) |
| 3 | 5.88 | 9.50 | 42 |
| | (149) | (241) | (19) |
| 4 | 6.62 | 11.50 | 74 |
| | (168) | (292) | (33) |
| 5 | 7.75 | 13.00 | 100 |
| | (197) | (330) | (45) |
| 6 | 8.25 | 14.00 | 125 |
| | (210) | (356) | (56) |
| 8 | 10.25 | 19.50 | 230 |
| | (260) | (495) | (104) |
| 10 | 12.00 | 24.50 | 490 |
| | (305) | (622) | (219) |
| 12 | 13.75 | 27.50 | 660 |
| | (349) | (699) | (317) |
| 14 | 15.50 | 31.00 | 794 |
| | (393) | (787) | (360) |
| 16 | 17.63 | 36.00 | 1020 |
| | (447) | (914) | (462) |
| 18 | 19.25 | 36.00 | 1304 |
| | (610) | (914) | (591) |
| 20 | 27.62 | 40.00 | 2590 |
| | (702) | (1016) | (1117) |
| 24 | 31 | 46.00 | 3840 |
| | (787) | (1168) | (1745) |

Materials of Construction

| No. | Description | Material | ASTM |
|-----|----------------------|---------------------------------|-------------------|
| 1 | Body | Cast Iron | A126 Class B |
| 2 | Cap | Cast Iron | A126 Class B |
| 4 | Disc | Bronze (2" - 6") | B584 C84400 |
| | | Cast Iron (8" - 24") | A126 Class B |
| 6 | Seat Ring | Bronze (2" - 12") | B584 C84400 |
| | | Bronze (14" - 24") | B584 C84400 |
| 7 | Disc Ring | Bronze (8" - 12") | B584 C84400 |
| | | Bronze (14" - 24") | B584 C84400 |
| 8 | Hinge Pin | Alum Silicon Bronze (2" - 8") | B150 C64200 |
| | | Naval Brass (10" - 12") | B21 C48200 |
| | | Stainless Steel (14" - 16") | |
| | | Stainless Steel (18" - 24") | |
| 19 | Hinge | Bronze (2" - 6") | B584 C84400 |
| | | Ductile Iron (8" - 12") | A536 Gr. 65-45-12 |
| | | Ductile Iron (18" - 24") | A536 Gr. 65-45-12 |
| | | Carbon Steel (14" - 16") | |
| 20 | Disc Stud | Steel (8" - 16") | A108 |
| | | Steel (18" - 24") | A108 |
| 21 | Disc Stud Pin | 18-8 Stainless Steel (8" - 16") | |
| | | Steel (18" - 24") | |
| 23 | Disc Nut | Brass (2" - 6") | B16 C36000 |
| | | Steel (8" - 24") | A563 Gr. A |
| 24 | Side Plug | Brass (2" - 16") | B16 C36000 |
| | | Ductile Iron (18" - 24") | A536 Gr. 65-45-12 |
| 25 | Disc Washer | Brass (2" - 6") | B36 |
| | | Steel (8" - 16") | |
| 26 | Lockwasher* | Steel (18" - 24") | |
| 27 | Plain Washer* | Steel (18" - 24") | |
| 28 | Hinge Pin Bushing* | Brass (2" - 12") | B16 C36000 |
| | | Bronze (14" - 16") | |
| 32 | Bonnet Gasket | Aramid Fibers with SBR Binder | |
| 33 | Cap Bolt | Carbon Steel | A307 Gr. B |
| 34 | Cap Bolt Nut | Carbon Steel | A563 Gr. A |
| 36 | Identification Plate | Aluminum | |

* Not shown

See page 5 for Pressure Temperature Ratings

Industry Standards

Military Specification: MIL-V-18436

MSS SP-71, Type 1

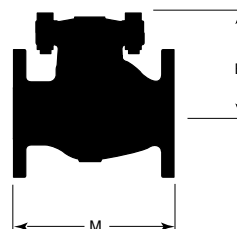

Class 125 • Bolted Cap • Bronze Trim • Flanged Ends

383 Lever and Weight Check Valve

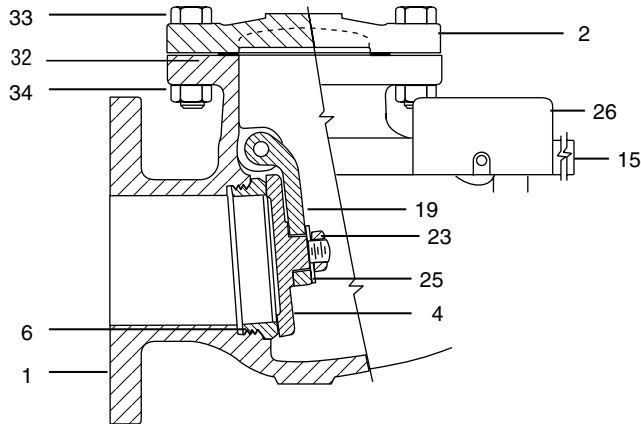

Dimensions and Weights
Inches (millimeters) - Pounds (kilograms)

| Valve Size | Dimensions | | WT |
|------------|------------|--------|--------|
| | B | M | |
| 2 | 4.50 | 8.00 | 30 |
| | (114) | (203) | (14) |
| 2 ½ | 5.38 | 8.50 | 40 |
| | (137) | (216) | (18) |
| 3 | 5.88 | 9.50 | 54 |
| | (149) | (241) | (24) |
| 4 | 6.62 | 11.50 | 85 |
| | (168) | (292) | (38) |
| 6 | 8.25 | 14.00 | 137 |
| | (210) | (356) | (62) |
| 8 | 10.25 | 19.50 | 240 |
| | (260) | (495) | (108) |
| 10 | 12.00 | 24.50 | 460 |
| | (305) | (622) | (208) |
| 12 | 13.75 | 27.50 | 700 |
| | (349) | (699) | (317) |
| 14 | 16.88 | 31.00 | 1060 |
| | (429) | (787) | (481) |
| 16 | 19.12 | 36.00 | 1500 |
| | (486) | (914) | (682) |
| 18 | 24.00 | 36.00 | 1970 |
| | (610) | (914) | (895) |
| 20 | 27.62 | 42.00 | 2590 |
| | (702) | (1067) | (1117) |
| 24 | 31.00 | 46.00 | 3840 |
| | (787) | (1168) | (1745) |

Materials of Construction

| No. | Description | Material | ASTM |
|-----|--------------------|--|-------------------|
| 1 | Body | Cast Iron | A126 Class B |
| 2 | Cap | Cast Iron | A126 Class B |
| 4 | Disc | Bronze (2" - 6") | B584 C84400 |
| | | Cast Iron (8") | A126 Class B |
| 6 | Body Seat Ring | Bronze | B584 C84400 |
| 7 | Disc Seat Ring* | Bronze (8") | B584 C84400 |
| 8 | Hinge Pin** | Exelloy | A276 Type 410 |
| 11 | Stuffing Box** | Brass | B16 C36000 |
| 12 | Packing** | Braided Flexible Graphite with Corrosion Inhibitor | |
| 14 | Packing Nut** | Bronze | B16 C36000 |
| 15 | Lever† | Ductile Iron | A536 Gr. 65-45-12 |
| 19 | Hinge† | Bronze (2" - 6") | B584 C84400 |
| | | Ductile Iron (8") | A536 Gr. 65-45-12 |
| 20 | Disc Stud* | Steel (8") | A108 |
| 21 | Disc Stud Pin* | 18-8 Stainless Steel (8") | |
| 22 | Hinge Pin Key** | Steel | A108 |
| 23 | Nut for Disc | Brass (2" - 6") | B16 C36000 |
| | | (8") Steel | A563 Gr. A |
| 24 | Hinge Pin Plug* | Brass | B16 C36000 |
| 25 | Disc Washer | Brass (2" - 6") | B36 |
| | | Steel (8") | |
| 26 | Weight† | Cast Iron | A126 Class B |
| 27 | Hinge Pin Bushing* | Bronze | B16 C36000 |
| 28 | Lever Washer** | Steel | |
| 29 | Coupling** | Ductile Iron | A536 Gr. 65-45-12 |
| 30 | Gib-Key** | Steel | |
| 31 | Lever Nut** | Steel Di-Chromate | |
| 32 | Gasket† | Aramid Fibers with SBR Binder | |
| 33 | Cap Bolts | Steel | A307 Gr. B |
| 34 | Cap Bolt Nuts | Steel | A563 Gr. A |
| 36 | ID Plate* | Aluminum | |

* Not shown

† Parts indicated are necessary for changing regular valve to outside lever and weight. See page 6 for Lever and Weight Technical Orientation Data

See page 5 for Pressure-Temperature Ratings

Industry Standards

MSS SP-71, Type 1

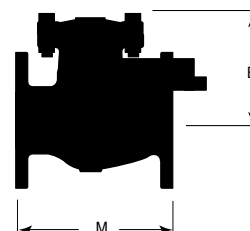

Class 125 • Bolted Cap • All Iron • Flanged Ends

373 1/2 Check Valve

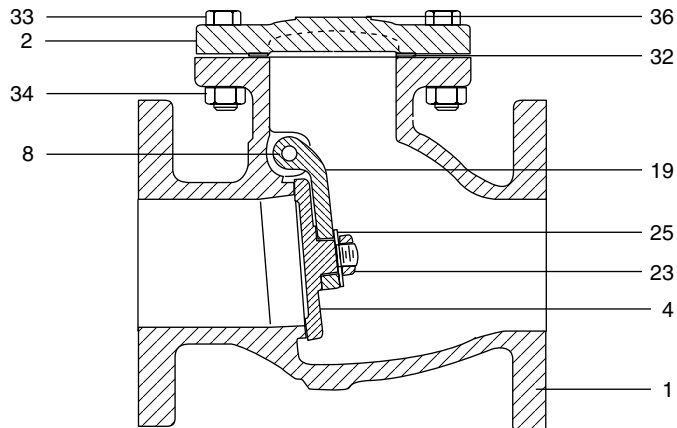

Dimensions and Weights Inches (millimeters) - Pounds (kilograms)

| Valve Size | Dimensions | | WT |
|------------|------------|--------|--------|
| | B | M | |
| 2 | 4.50 | 8.00 | 25 |
| | (114) | (203) | (11) |
| 2 1/2 | 5.38 | 8.50 | 30 |
| | (137) | (216) | (13) |
| 3 | 5.88 | 9.50 | 42 |
| | (149) | (241) | (19) |
| 4 | 6.62 | 11.50 | 74 |
| | (168) | (292) | (33) |
| 5 | 7.75 | 13.00 | 100 |
| | (197) | (330) | (45) |
| 6 | 8.25 | 14.00 | 125 |
| | (210) | (356) | (56) |
| 8 | 10.25 | 19.50 | 230 |
| | (260) | (495) | (104) |
| 10 | 12.00 | 24.50 | 440 |
| | (305) | (622) | (200) |
| 12 | 13.75 | 27.50 | 660 |
| | (349) | (699) | (299) |
| 14 | 16.88 | 31.00 | 1060 |
| | (429) | (787) | (481) |
| 16 | 19.12 | 36.00 | 1500 |
| | (486) | (914) | (682) |
| 18 | 24.00 | 38.00 | 1970 |
| | (610) | (965) | (895) |
| 20 | 27.62 | 42.00 | 2590 |
| | (702) | (1067) | (1117) |
| 24 | 31.00 | 46.00 | 3840 |
| | (787) | (1168) | (1745) |

Materials of Construction

| No. | Description | Material | ASTM |
|-----|----------------------|---|-------------------|
| 1 | Body | Cast Iron | A126 Class B |
| 2 | Cap | Cast Iron | A126 Class B |
| 4 | Disc | Ductile Iron (2" - 4") | A536 Gr. 65-45-12 |
| | | Cast Iron (6" - 24") | A126 Class B |
| 6 | Seat Ring* | Cast Iron (5", 10" - 24") | A126 Class B |
| | | Cast Iron (2" - 4", 6" - 8") (Integral) | A126 Class B |
| 8 | Hinge Pin | Stainless Steel | A276 Type 410 |
| 19 | Hinge | Ductile Iron | A536 Gr. 65-45-12 |
| 20 | Disc Stud | Steel (8" - 16") | A108 |
| | | Steel (18" - 24") | A108 |
| 21 | Disc Stud Pin | 18-8 Stainless Steel (8" - 16") | |
| | | Steel (18" - 24") | |
| 23 | Disc Nut | Steel (8" - 24") | A563 Gr. A |
| 24 | Side Plug* | Carbon Steel (2" - 12") | |
| | | Ductile Iron (14" - 24") | A536 Gr. 65-45-12 |
| 25 | Disc Washer | Carbon Steel (2" - 12") | |
| 26 | Lockwasher* | Steel (14" - 24") | |
| 27 | Plain Washer* | Steel (14" - 24") | |
| 28 | Hinge Pin Bushing* | Carbon Steel (2" - 12") | A108 Gr. 1018 |
| 32 | Cap Gasket | Aramid Fibers with SBR Binder | |
| 33 | Cap Bolt | Carbon Steel | A307 Gr. B |
| 34 | Cap Bolt Nut | Carbon Steel | A563 Gr. A |
| 36 | Identification Plate | Aluminum | |

* Not shown

See page 5 for Pressure Temperature Ratings

Industry Standards

Military Specification: MIL-V-18436

MSS SP-71, Type 1

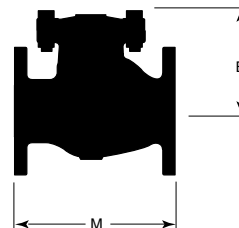

Class 250 • Bolted Cap • Bronze Trim • Flanged Ends

39E Check Valve

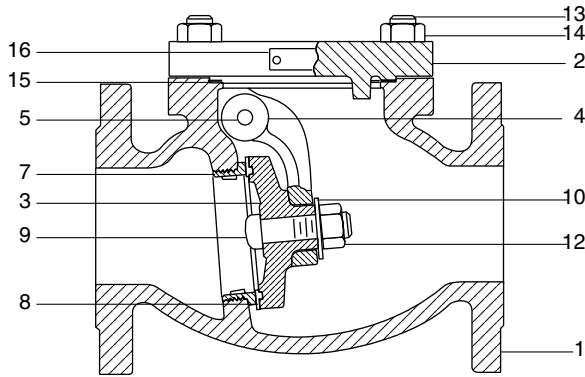

Materials of Construction

| No. | Description | Material | ASTM |
|-----|----------------------|----------------------------------|-------------------|
| 1 | Body | Cast Iron | A126 Class B |
| 2 | Cap | Cast Iron | A126 Class B |
| 3 | Disc | Bronze (2" - 3") | B584 C84400 |
| | | Cast Iron (4" - 8") | A126 Class B |
| 4 | Hinge | Ductile Iron | A536 Gr. 65-45-12 |
| 5 | Hinge Pin | 13 Cr. Stainless Steel (2" - 3") | A276 Type 410 |
| | | Bronze (4" - 8") | |
| 6 | Hinge Pin Plug* | Bronze | B16 C36000 |
| 7 | Body Seat Ring | Bronze | B584 C84400 |
| 8 | Disc Seat Ring | Bronze (4" - 8") | B584 C84400 |
| 9 | Disc Bolt | Steel (4" - 8") | |
| 10 | Disc Nut Washer | Steel | |
| 12 | Disc Bolt Nut | Steel - Dichromate Fin. | |
| 13 | Cap Studs | Steel | A108 |
| 14 | Cap Stud Nuts | Steel | A563 Gr. A |
| 15 | Gasket | Aramid Fibers with SBR Binder | |
| 16 | Identification Plate | Aluminum | |

* Not shown

See page 5 for Pressure Temperature Ratings

Industry Standards

Military Specification: MIL-V-18436 Group B, Type 3, Trim 5
MSS SP-71, Type 1

Dimensions and Weights

Inches (millimeters) - Pounds (kilograms)

| Valve Size | Dimensions | | WT |
|------------|------------|-------|-------|
| | B | M | |
| 2 | 5.25 | 10.50 | 46 |
| | (133) | (267) | (21) |
| 2 ½ | 6.00 | 11.50 | 64 |
| | (152) | (292) | (29) |
| 3 | 6.25 | 12.50 | 90 |
| | (159) | (318) | (41) |
| 4 | 7.25 | 14.00 | 133 |
| | (184) | (356) | (60) |
| 6 | 9.00 | 17.50 | 250 |
| | (229) | (445) | (113) |
| 8 | 11.00 | 21.00 | 410 |
| | (279) | (533) | (185) |

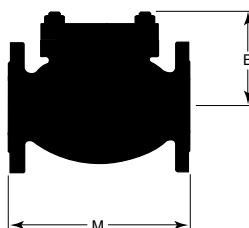

Class 300 • Threaded Cap • Y-Pattern • All Iron • Threaded

346 1/2 Check Valve

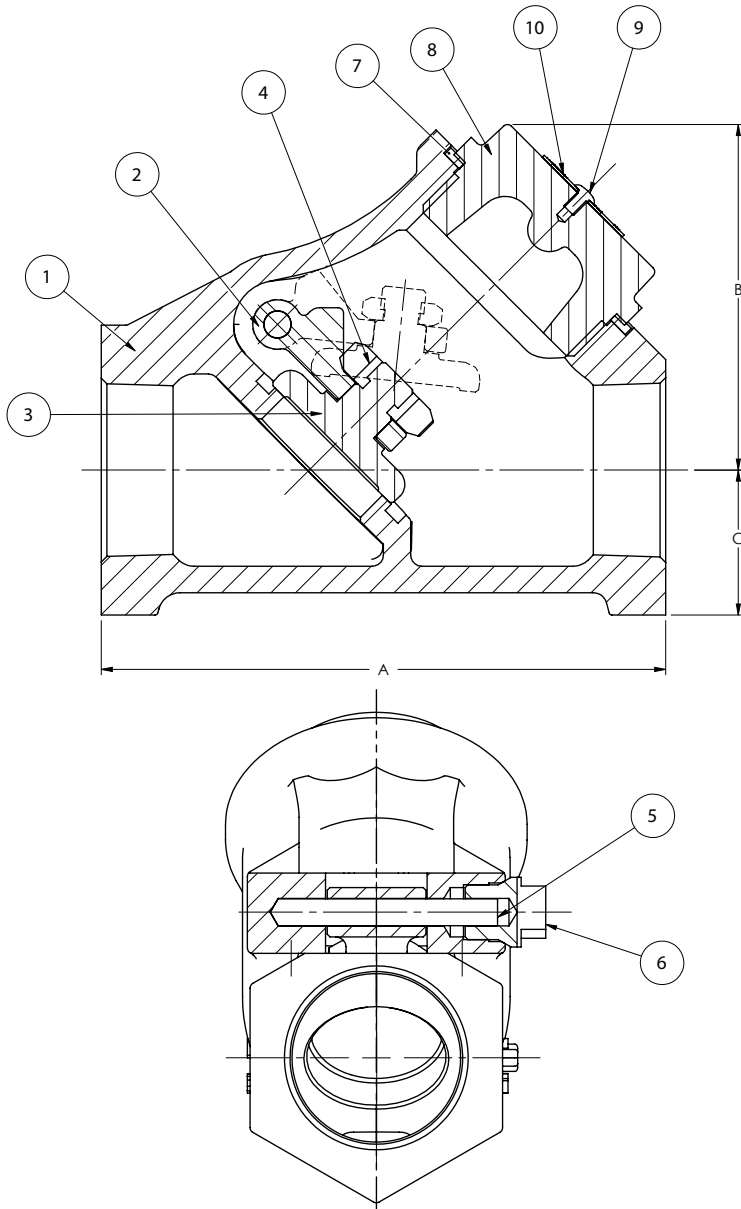

| Temperature Valve Ratings | | Working Pressures, Non-shock, PSI | |
|---------------------------|-----------|-----------------------------------|------|
| °F | °C | PSI | kPa |
| -20 to 100 | -30 to 37 | 640 | 4412 |
| 200 | 93 | 600 | 4136 |
| 300 | 149 | 565 | 3895 |
| 400 | 205 | 525 | 3619 |
| 500 | 260 | 495 | 3412 |
| 600 | 315 | 465 | 3206 |
| 650 | 343 | 450 | 3102 |

Materials of Construction

| No. | Description | Material | ASTM |
|-----|-------------|--|----------------|
| 1 | Body | Ductile Iron | A536, 65-45-12 |
| 2 | Hinge | Ductile Iron | A536, 65-45-12 |
| 3 | Disc | Ductile Iron | A536, 65-45-12 |
| 4 | Nut | Steel | A194 2H |
| 5 | Hinge Pin | Stainless Steel | AISI 410 |
| 6 | Plug | Stainless Steel | AISI 304 |
| 7 | Gasket | Aramid Fiber Blend with Nitrile Binder | |
| 8 | Bonnet Cap | Ductile Iron | A536, 65-45-12 |
| 9 | Rivet | Steel | |
| 10 | ID Tag | Anodized Aluminum B&S Gauge #24 | |

Industry Standards

MSS SP-71

ASME B1.20.1

Dimensions and Weights

Inches (millimeters) - Pounds (kilograms)

| Valve Size | Dimensions | | | WT |
|------------|------------|-------|------|--------|
| | A | B | C | |
| 1/2 | 2.75 | 1.69 | 1.06 | 1.34 |
| | (70) | (43) | (27) | (.61) |
| 3/4 | 3.27 | 1.90 | 1.06 | 1.67 |
| | (83) | (48) | (27) | (.76) |
| 1 | 4.06 | 2.45 | 1.06 | 2.50 |
| | (103) | (62) | (27) | (1.11) |
| 1 1/4 | 4.75 | 2.85 | 1.30 | 3.52 |
| | (120) | (73) | (32) | (1.60) |
| 1 1/2 | 5.40 | 3.29 | 1.40 | 5.42 |
| | (137) | (84) | (36) | (2.46) |
| 2 | 6.62 | 4.28 | 1.70 | 9.19 |
| | (168) | (109) | (43) | (4.17) |

CRANE®

CRANE ChemPharma & Energy

CRANE Energy Global Headquarters
4526 Research Forest Drive, Suite 400
The Woodlands, Texas 77381 U.S.A.
Tel.: (1) 936-271-6500
Fax.: (1) 936-271-6510

CRANE Customer Service
2129 3rd Avenue, S.E.
Cullman, Alabama 35055
Tel.: (1) 256-775-3800
Fax.: (1) 256-775-3860

www.cranechempharma.com
www.craneenergy.com

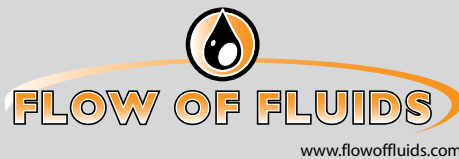

brands you trust.



CP_EG-CR-CT-EN-L16-03-2013-11 (CV-302)

Crane Co., and its subsidiaries cannot accept responsibility for possible errors in catalogues, brochures, other printed materials, and website information. Crane Co. reserves the right to alter its products without notice, including products already on order provided that such alteration can be made without changes being necessary in specifications already agreed. All trademarks in this material are property of the Crane Co. or its subsidiaries. The Crane and Crane brands logotype, in alphabetical order, (ALOYCO®, CENTER LINE®, COMPAC-NOZ®, CRANE®, DEPA® & ELRO®, DUO-CHEK®, FLOWSEAL®, JENKINS®, KROMBACH®, NOZ-CHEK®, PACIFIC®, RESISTOFLEX®, REVO®, SAUNDERS®, STOCKHAM®, TRIANGLE®, UNI-CHEK®, VALVES®, WTA®, and XOMOX®) are registered trademarks of Crane Co. All rights reserved.