

XOMOX[®]

XOMOX[®] LINED
BALL VALVES
SERIES XLB-FEO



TECHNICAL DATASHEET

CRANE[®]

v in

www.cranecpe.com

Lined Ball Valves Features and Benefits

Product Specifications

Materials of Construction

- **Body:** EN 1563 / EN-GJS-400-18-LT (5.3103) / ASTM A395 / 60-40-18, PFA, PFA antistatic, PVDF
- **Ball:** 1.4470/ASTM A995 Gr 4A, PFA, PFA antistatic, PVDF

Size Range

- ½"/DN15 through 6"/DN150 full port
- 1½" Through 8" reduced port
- Other sizes available up to 12"/DN300

Pressure Ratings

- ASME Class 150, PN16 and JIS10

Temperature Range

- -20°F (-29°C) to 400°F (204°C)

Options

- Chlorine application
- Oxygen application
- Other painting on request
- Complies with ATEX, European Directive 2014/34/EU

- PVDF Lining
- Flow Characterization – V port

Industries

- Chlor-Alkali
- Industrial Inorganic Chemicals
- Metal and Mining
- Pharmaceutical
- Nitrogen and Phosphatic Fertilizers
- Petroleum Refining

Applications

- Chlorine
- Brine
- Benzene
- Bromine
- Sulfuric Acid
- Nitric Acid
- Hydrochloric Acid
- Phosphoric Acid
- Sea Water

Features and Benefits

1

SX Seal

Innovative patented SX seal that moves in conjunction with the spherical portion of the stem, maintaining a constant seal delivering

2

Lower Torques

Easy to operate smaller actuators, and reduced total costs

3

Longer Life

Compact design leads to weight savings, which is easy for end-users to install in service and allows installation in space restricted areas

Lined Ball Valves Exploded View

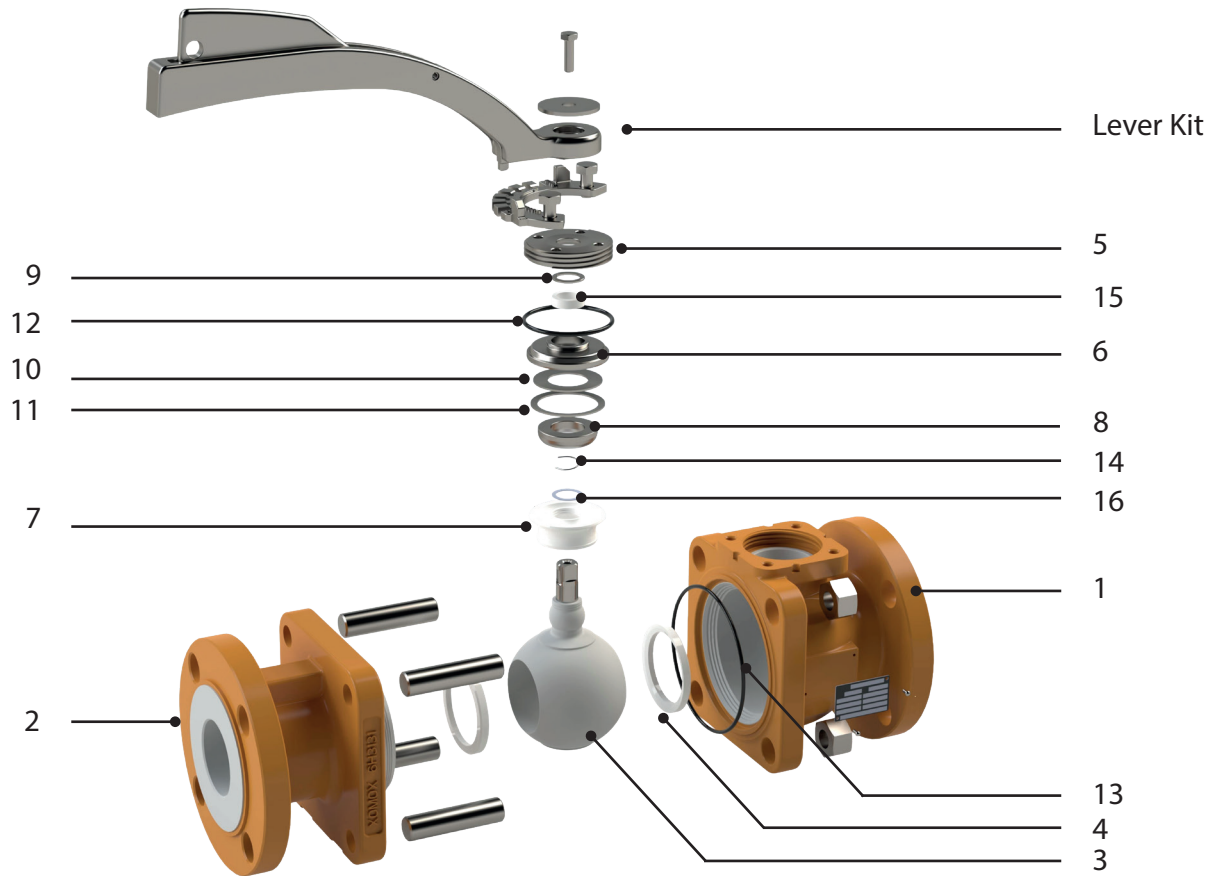

No.	Component	DI/PFA	SS/PFA
1	Body	DI/PFA	CF8M/PFA
2	Tail	DI/PFA	CF8M/PFA
3	Ball-stem	1.4470/PFA	1.4470/PFA
4	Seat ring	Chemically modified PTFE	Chemically modified PTFE
5	Cover	17-4PH	17-4PH
6	Stuffing box	17-4PH	17-4PH
7	SX-seal	Chemically modified PTFE	Chemically modified PTFE
8	Wedge Ring	1.4404	1.4404
9	Follower	1.4541	1.4541
10	Spring washer	1.4310	1.4310
11	SX Press Ring	1.4451	1.4451
12	O-ring	FKM	FKM / FVMQ (on request for low temperature applications)
13	O-ring	FKM	FKM / FVMQ (on request for low temperature applications)
14	Static eliminator	1.4310	1.4310
15	PTFE packing rope	PTFE	PTFE
16	Washer	1.4310	1.4310

*See "How To Order" section for further material selections.

Lined Ball Valves XLB-FE0 24A

XOMOX® Fully Lined Ball Valve Full Port

Flange Connection EN 1092-2 PN16

Face-to-Face Dimension acc. to EN 558

(Table 2, Row1) (Former R201)

Available in ductile iron and stainless steel

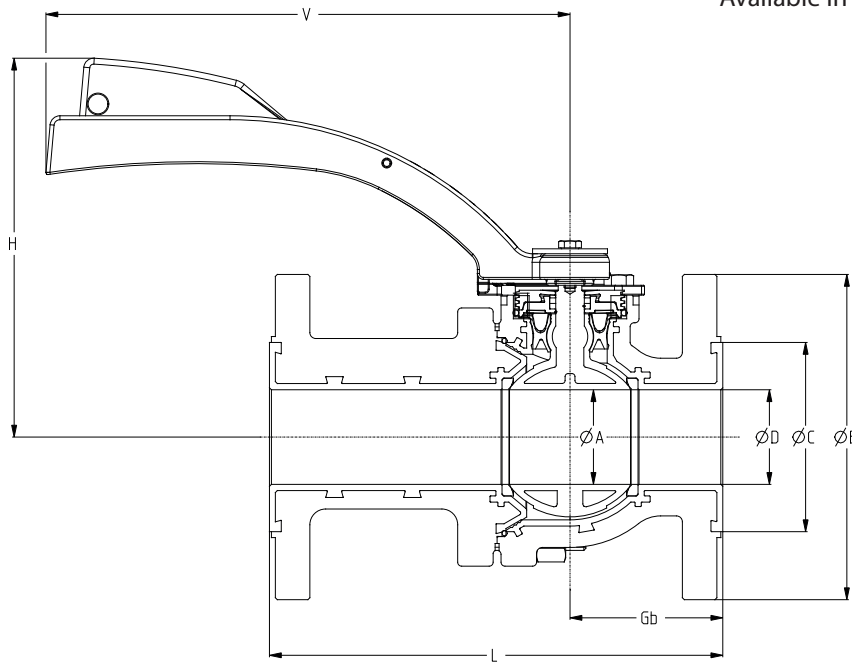

Dimensions in mm

DN	A	C	D	E	L	Gb	H	V	Weight	ISO 5211
									kg	
15	23	45	15	95	130	55.3	140	170	4.2	F05
20	23	58	20	105	150	55.3	140	170	4.7	F05
25	23	68	23	115	160	54.3	140	170	5.7	F05
32	37	78	32	140	180	70	183	266	9.2	F07
40	37	88	37	150	200	70	183	266	11	F07
50	48	102	48	165	230	77.5	191	266	13.5	F07
65/50*	48	122	48	185	290	80.7	191	266	17	F07
80	75	138	75	190	310	85.5	216	350	29	F10
100	98	158	98	220	350	98.3	242	350	42	F10
150	145	212	145	285	480	129.4	271	350	77	F12

* DN 65 is standard port valve

Flow Coefficient										
DN	15	20	25	32	40	50	65 - 50	80	100	150
Cv	12.6	35	57	72	213	295	215	670	1650	3440
Kv [m ³ /h]	10.9	31	49	62	184	255	186	580	1427	2976

Lined Ball Valves XLB-FE0 12A

XOMOX® Fully Lined Ball Valve Full Port
 Flange Connection ASME B16.5 - Class 150
 Face-to-Face Dimension
 ASME B16.10 (Former 911)
 Available in ductile iron and stainless steel

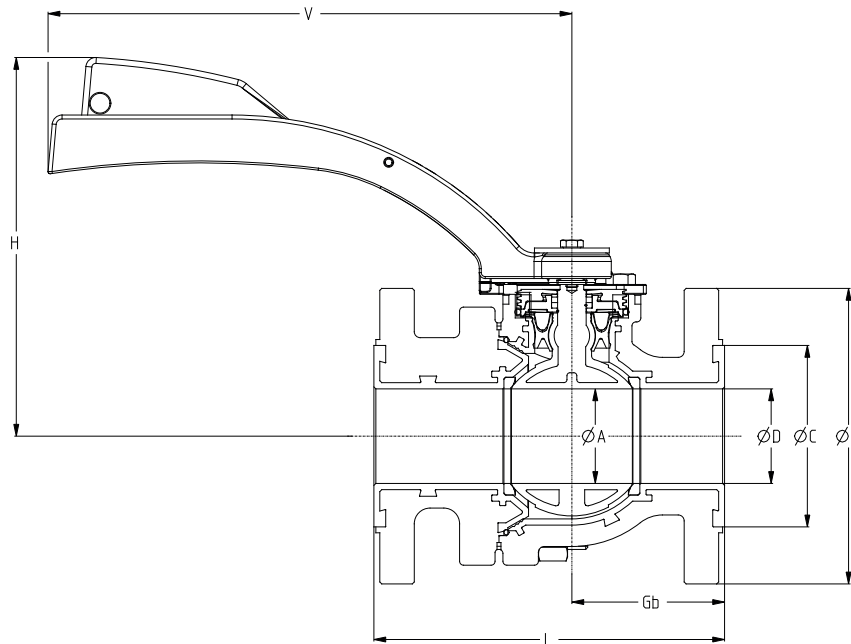

Dimensions in inches/mm

Size	A		C		D		E		L		Gb		H		V		Weight		ISO 5211
	in	mm	in	mm	in	mm	in	mm	in	mm	in	mm	in	mm	in	mm	lb	Kg	
1/2"*	0.91	23	1.38	35	0.59	15	3.50	89	5.12	130	2.05	52	5.51	140	6.69	170	8.6	3.9	F05
3/4"*	0.91	23	1.69	43	0.79	20	3.88	98	5.91	150	2.05	52	5.51	140	6.69	170	9.5	4.3	F05
1"	0.91	23	2.01	51	0.91	23	4.25	108	5.00	127	2.01	51	5.51	140	6.69	170	10.3	4.7	F05
1 1/2"	1.46	37	2.87	73	1.46	37	5.00	127	6.50	165	2.64	67	7.20	183	10.47	266	20	9	F07
2"	1.85	47	3.62	92	1.85	47	6.00	152	7.00	178	2.95	75	7.52	191	10.47	266	26	11.6	F07
3"	2.95	75	5.00	127	2.95	75	7.50	191	8.00	203	3.39	86	8.50	216	13.78	350	51	23	F10
4"	3.82	97	6.18	157	3.82	97	9.00	229	9.00	229	3.86	98	9.53	242	13.78	350	81	37	F10
6"	5.71	145	8.50	216	5.71	145	11.00	279	10.50	267	4.65	118	10.67	271	13.78	350	130	59	F12

* Ductile iron 1/2" and 3/4" valves are XLB-FE0 13 long pattern valve

* Contact CRANE ChemPharma Sales Office for dimensions of 1/2" and 3/4" stainless steel valves

* Flange holes on 1/2" and 3/4" valves are threaded UNC 1/2"-13

Flow Coefficient								
Size	1/2"	3/4"	1"	1 1/2"	2"	3"	4"	6"
Cv	12.6	35	57	213	295	670	1650	3440
Kv [m ³ /h]	10.9	31	49	184	255	580	1427	2976

Lined Ball Valves XLB-FE0 13A

XOMOX® Fully Lined Ball Valve Full Port
 Flange Connection ASME B16.5 - Class 150
 Face-to-Face Dimension Long Pattern
 (former R202)

Available in ductile iron only

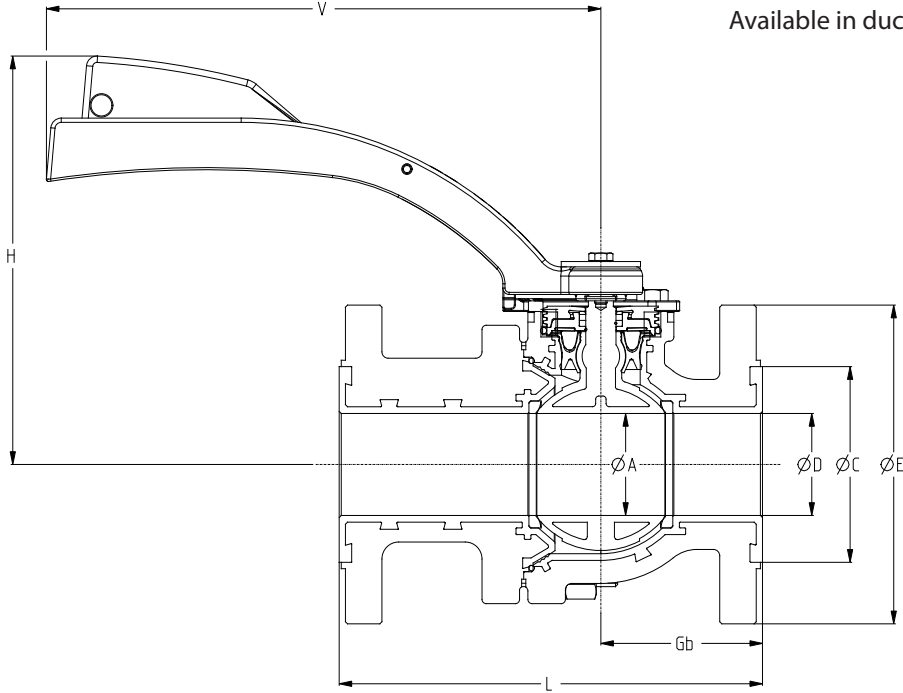

Dimensions in inches/mm

Size	A		C		D		E		L		Gb		H		V		Weight		ISO 5211
	in	mm	in	mm	in	mm	in	mm	in	mm	in	mm	in	mm	in	mm	lb	Kg	
1/2"*	0.91	23	1.38	35	0.59	15	3.50	89	5.12	130	2.05	52	5.51	140	6.69	170	8.6	3.9	F05
3/4"*	0.91	23	1.69	43	0.79	20	3.88	98	5.91	150	2.05	52	5.51	140	6.69	170	9.5	4.3	F05
1"	0.91	23	2.01	51	0.91	23	4.25	108	6.00	152.3	2.01	51	5.51	140	6.69	170	11	5	F05
1 1/2"	1.46	37	2.87	73	1.46	37	5.00	127	7.01	178	2.64	67	7.20	183	10.47	266	20	9	F07
2"	1.85	47	3.62	92	1.85	47	6.00	152	7.99	203	2.95	75	7.52	191	10.47	266	26	12	F07
3"	2.95	75	5.00	127	2.95	75	7.50	191	9.49	241	3.39	86	8.50	216	10.47	350	55	25	F10
4"	3.82	97	6.18	157	3.82	97	9.00	229	11.50	292	3.86	98	9.53	242	13.78	350	86	39	F10
6"	5.71	145	8.50	216	5.71	145	11.00	279	14.02	356	4.65	118	10.67	271	13.78	350	147	67	F12

* Flange holes on 1/2" and 3/4" valves are threaded UNC 1/2"-13

Flow Coefficient								
Size	1/2"	3/4"	1"	1 1/2"	2"	3"	4"	6"
Cv	12.6	35.0	57	213	295	670	1650	3440
Kv [m3/h]	10.9	31.0	49	184	255	580	1427	2976

Lined Ball Valves XLB-FE0 42A

XOMOX® Fully Lined Ball Valve Standard Port
 Flange Connection ASME B16.5 - Class 150
 Face-to-Face Dimension acc. ASME B16.10
 (former 944)

Available in ductile iron only

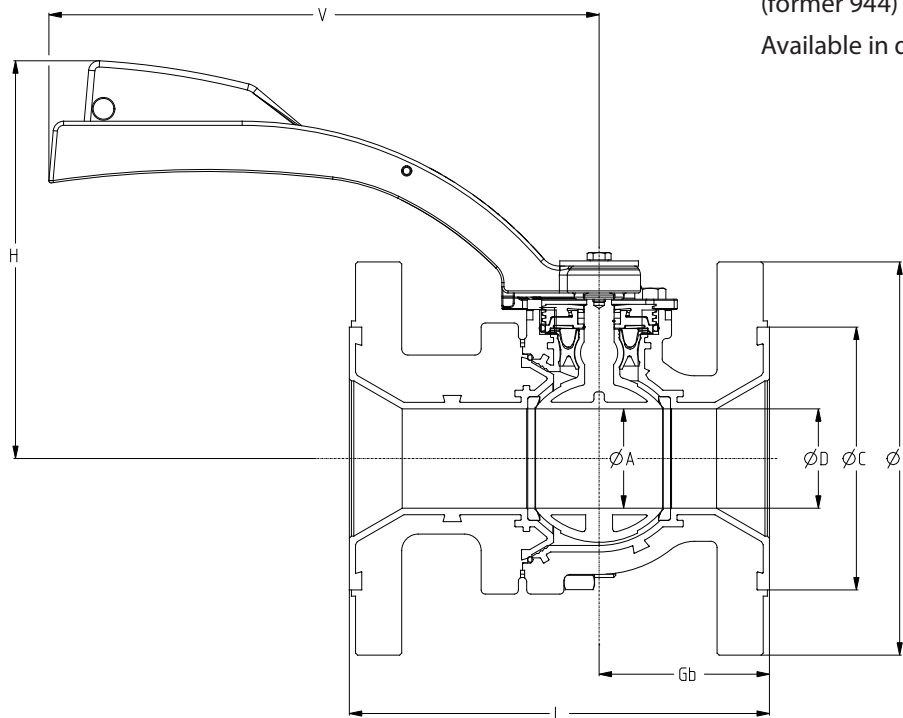

Dimensions in inches/mm

Size	A		C		D		E		L		Gb		H		V		Weight		ISO 5211
	in	mm	in	mm	in	mm	in	mm	in	mm	in	mm	in	mm	in	mm	lb	Kg	
1"*	0.91	23	2.01	51	0.91	23	4.25	108	5.00	127	2.01	51	5.51	140	6.69	170	10.3	4.7	F05
1 ½"	0.91	23	2.87	73	1.57	40	5.00	127	6.50	165	2.24	56	5.51	140	6.69	170	13	6	F05
2"	1.46	37	3.62	92	1.97	50	6.00	152	7.00	178	2.95	75	7.20	183	10.47	266	23	10.5	F07
3"	1.85	47	5.00	127	3.15	80	7.50	191	8.00	204	3.23	82	7.52	191	10.47	266	35	16	F07
4"	2.95	75	6.18	157	3.94	100	9.00	229	9.00	228	3.82	98	8.50	216	13.78	350	64	29	F10
6"	3.82	97	8.50	216	5.91	150	11.00	279	10.50	267	3.90	109	9.53	242	13.78	350	97	44	F10
8"	5.71	145	10.63	270	7.79	198	13.50	343	11.49	292	5.12	130	10.67	271	13.78	350	163	74	F12

* 1" valve is XLB-FE0 12 Full Port valve

Flow Coefficient							
Size	1"	1 ½"	2"	3"	4"	6"	8"
Cv	57	50	190	199	598	996	1832
Kv [m ³ /h]	49	43	164	172	517	862	1671

Lined Ball Valves XLB-FE0 35A

XOMOX® Fully Lined Ball Valve Full Port
 Flange Connection JIS B2210 for 10kg
 Face-to-Face Long Pattern (former R203)
 Available in ductile iron only

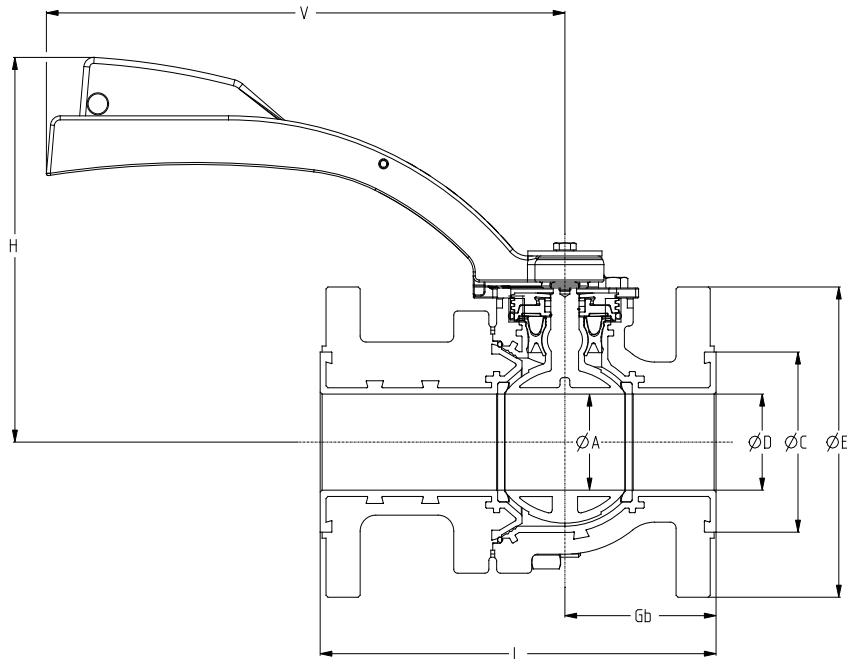

Dimensions in mm

DN	A	C	D	E	L	Gb	H	V	Weight	ISO 5211
									kg	
15	23	52	15	95	130	55.3	135	170	4.3	F05
20	23	58	20	100	150	55.3	140	170	4.5	F05
25	23	67	23	125	160	54.3	140	170	6	F05
32	37	81	37	140	200	70	183	266	9.2	F07
40	48	96	48	155	203	77.5	191	266	10.5	F07
50	48	116	48	175	290	80.7	191	266	12	F07
65/50	75	126	75	190	310	85.5	216	266	16	F07
80	98	151	98	210	350	98.3	242	350	27	F10
100	97	155	97	210	350	98	242	350	39	F10
150	145	215	145	280	356	118	271	350	68	F12

* DN 65 is standard port valve

Flow Coefficient

DN	15	20	25	32	40	50	65 - 50	80	100	150
Cv	12.6	35	57	72	213	295	295	670	1650	3440
Kv [m ³ /h]	10.9	31	49	62	184	255	255	580	1427	2976

Lined Ball Valves XLB-FE0 32A

XOMOX® Fully Lined Ball Valve Full Port
 Flange Connection JIS B2210 for 10kg
 Face-to-Face ASME B16.10
 Available in stainless steel only

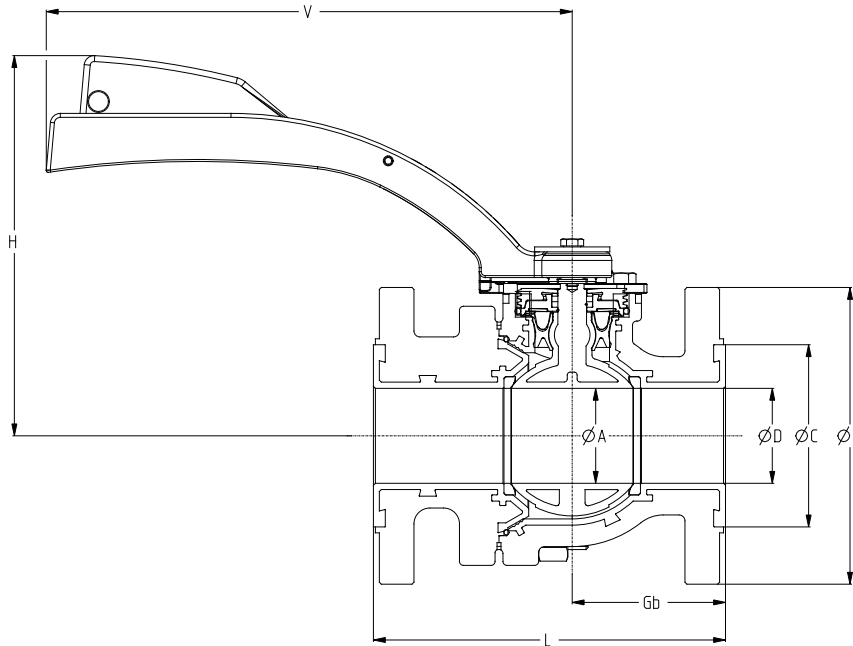

Dimensions in mm

DN	A	C	D	E	L	Gb	H	V	Weight	ISO 5211
									kg	
15	23	52	15	95	108	52	140	170	4.3	F05
20	23	58	20	100	117	52	140	170	4.5	F05
25	23	67	23	125	127	51	140	170	4.7	F05
40	37	81	37	140	165	67	183	266	9	F07
50	47	96	47	155	178	75	191	266	12	F07
80	75	126	75	185	203	86	216	350	23	F10
100	97	151	97	210	229	98	242	350	37	F10
150	145	216	145	280	267	118	271	350	59	F12

* DN 65 is standard port valve

Flow Coefficient									
DN	15	20	25	40	50	80	100	150	
Cv	12.6	35	57	213	295	670	1650	3440	
Kv [m ³ /h]	10.9	31	49	184	255	580	1427	2976	

Lined Ball Valves Flow Characteristics

Flow Characteristics Full Port Valves Kv [m3/h] = f (DN, Angle of aperture)

Angle of Aperture		9°	18°	27°	36°	45°	54°	63°	72°	81°	90°
Angle of Aperture %		10	20	30	40	50	60	70	80	90	100
DN	in										
15	½	0.05	0.14	0.29	0.45	0.83	1.2	2.1	3	6.2	11
20	¾	0.21	0.47	1	1.52	2.55	3.57	5.84	8.1	17.3	31
25	1	0.34	0.76	1.6	2.45	4.1	5.75	9.4	13	28	50
32*	1¼	0.73	1.58	3.43	5.18	8.56	11.25	18.3	24.4	59.9	61.8
40	1 ½	1.12	2.45	5.28	8.11	13.8	19.4	35.2	51	104	184
50	2	1.32	2.87	6.17	9.46	16	22.6	44.3	66	142	255
65**	2½	1.07	2.27	4.81	7.19	12.16	16.98	33.1	48.9	105.8	186.2
80	3	2.86	7.61	15.7	23.8	38.15	52.5	100	149	321	578
100	4	7	17	36	55	87	121	244	367	791	1427
150	6	18	49	100	152	243	334	505.4	769	1652	2976

* with ball/stem DN40 Cv = 1.156Kv
 ** with ball/stem DN50

FL,KT ZY, = f (Angle of aperture)

Angle of Aperture	9°	18°	27°	36°	45°	54°	63°	72°	81°	90°
Rated Travel	0.1	0.2	0.3	0.4	0.5	0.6	0.7	0.8	0.9	1
Recovery Factor FL	0.91	0.91	0.9	0.88	0.85	0.8	0.74	0.67	0.57	0.28
Valve Characteristic ZY	0.52	0.52	0.51	0.49	0.47	0.43	0.38	0.33	0.26	0.09
Pressure Differential Ratio KT	0.7	0.7	0.68	0.65	0.61	0.54	0.46	0.38	0.27	0.07

Flow Characteristics Standard Port Valves Kv [m3/h] = f (DN, Angle of aperture)

Angle of Aperture		9°	18°	27°	36°	45°	54°	63°	72°	81°	90°
Angle of Aperture %		10	20	30	40	50	60	70	80	90	100
DN	in										
40	1 ½	0.26	0.57	1.24	1.9	3.23	4.54	8.25	11.95	24.36	43.1
50	2	0.85	1.84	3.96	6.08	10.28	14.52	28.46	42.39	91.21	163.79
80	3	0.85	2.27	4.68	7.1	11.38	15.66	29.83	44.45	95.75	172.41
100	4	2.36	6.3	13.03	19.76	31.71	43.71	88.28	132.85	286.69	517.24
150	6	3.76	10.12	20.85	31.62	50.63	69.64	146.34	222.58	478.56	862.07
200	8	12.72	20	40.4	61.32	98.4	135	257.1	431.3	930.8	1671

Cv = 1.156Kv

Angle of Aperture	9°	18°	27°	36°	45°	54°	63°	72°	81°	90°
Rated Travel	0.1	0.2	0.3	0.4	0.5	0.6	0.7	0.8	0.9	1
Recovery Factor FL	---	0.95	0.94	0.92	0.89	0.87	0.85	0.8	0.7	0.65
Valve Characteristic Z _y	---	0.51	0.49	0.47	0.43	0.38	0.33	0.26	0.09	0.05
Pressure Differential Ratio K _T	---	0.64	0.64	0.72	0.79	0.61	0.51	0.37	0.24	0.16

Lined Ball Valves Performance

Pressure/Temperature Diagram

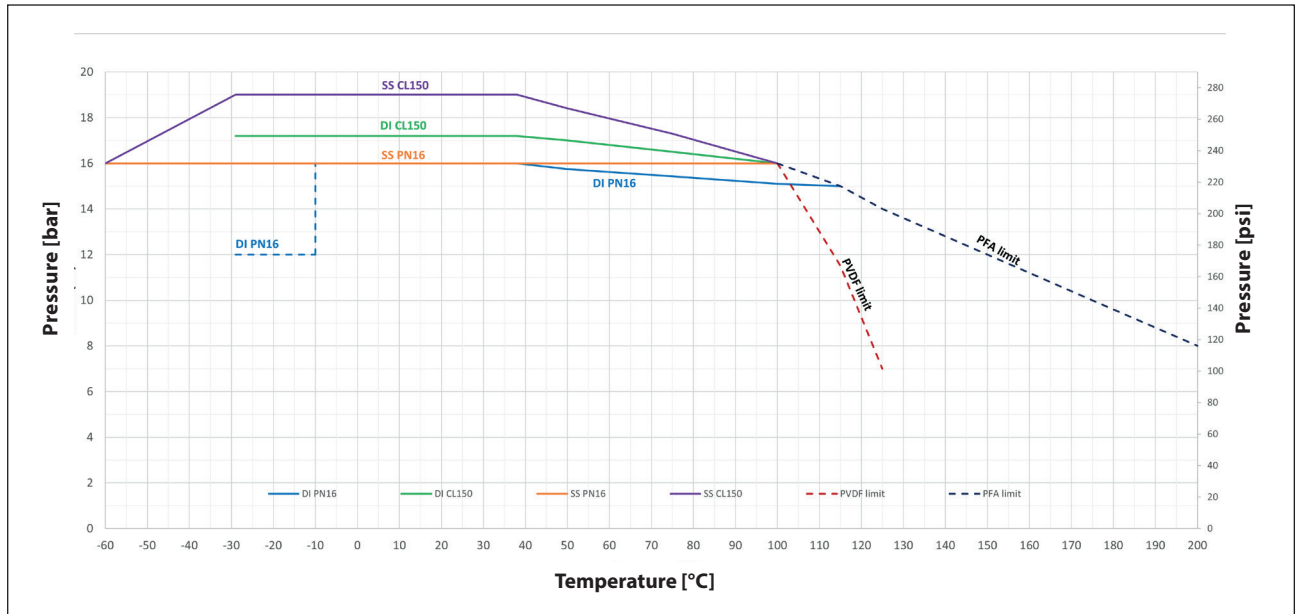

Vacuum/Temperature Diagram

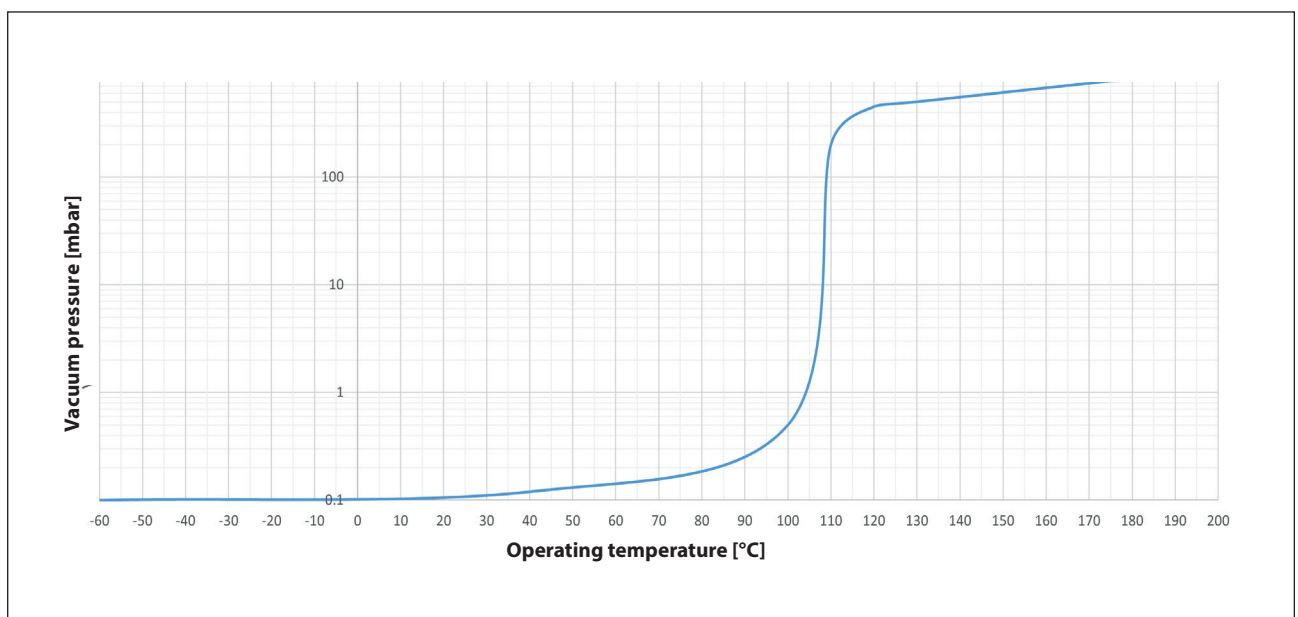

Notes

1. Body material (EN-GJS-400-18-LT (5.3103) / 60-40-18) meets the requirements of both EN 1563 and ASTM A395
2. Minimum temperature for ductile iron material (60-40-18) according to ASME B16.42 is -20° F (-29° C)
3. Minimum temperature for EN-GJS-400-18-LT (5.3103) is -10° C (-14° F)
4. For valves with ductile iron bodies maximum cold working gauge pressure for JIS 10Kg is 10 bar (145 psig) for EN PN16 is 16 bar (232 psig) and ASME Class 150 is 250 psig (17.2 bar). For valves with stainless steel bodies, ASME Class 150 is 278 psig (19.2 bar).
5. Contact your Crane ChemPharma & Energy sales office for applications outside the relevant pressure and temperature limits of the design code in question (dash line).

Lined Ball Valves Torques and Actuators Mounting

Operating Torques (max. break-away torque)

Full Port Size		Standard Port Size		ΔP up to 5 bar	ΔP up to 70 psi	ΔP up to 10 bar	ΔP up to 145 psi	ΔP up to 17.6 bar	ΔP up to 250 psi
DN	in	DN	in	Nm at 20°C	in/lb at 70°F	Nm at 20°C	in/lb at 70°F	Nm at 20°C	in/lb at 70°F
15	1/2"	-	-	8	71	8	71	9	80
20	3/4"	-	-	8	71	8	71	9	80
25	1"	40	1 1/2"	8	71	8	71	9	80
32	1 1/4"	-	-	12	106	13	115	20	177
40	1 1/2"	50	2"	12	106	13	115	20	177
50	2"	80	3"	19	168	20	177	25	221
50/65	2 1/2"	-	-	19	168	20	177	25	221
80	3"	100	4"	35	310	55	487	70	620
100	4"	150	6"	77	682	90	797	100	885
150	6"	200	8"	154	1363	190	1682	260	2301

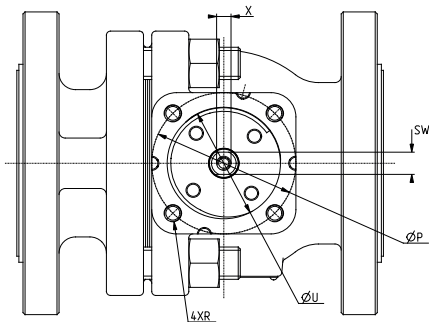

Top View

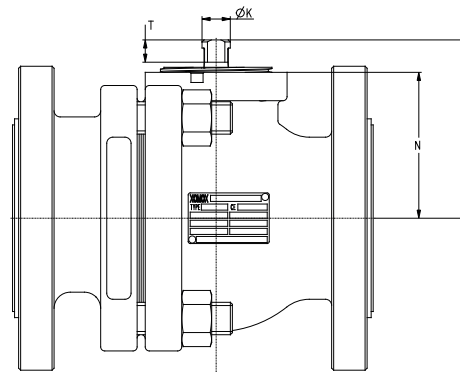

Side View

Actuator Mounting Dimensions

Full Port Size		Standard Port Size		ISO 5211	U	4XR	P	SW	T	K	X	N	Q
DN	in	DN	in										
15	1/2"	-	-	F05	35	M6	50	9	9	12	M6	48	62
20	3/4"	-	-	F05	35	M6	50	9	9	12	M6	48	62
25	1"	40	1 1/2"	F05	35	M6	50	9	9	12	M6	48	62
32	1 1/4"	-	-	F07	55	M8	70	11	11	14	M6	62	78
40	1 1/2"	50	2"	F07	55	M8	70	11	11	14	M6	62	78
50	2"	80	3"	F07	55	M8	70	11	11	14	M6	70	86
65	2 1/2"	-	-	F07	55	M8	70	11	11	14	M6	70	86
80	3"	100	4"	F10	70	M10	102	17	17	22	M8	100	122
100	4"	150	6"	F10	70	M10	102	17	17	22	M8	126	148
150	6"	200	8"	F12	85	M12	125	22	22	28	M8	155	182

Lined Ball Valves How to Order

2" — XLB		— 1	— 2	— A	— 1	— P6	— 28	— P16	— H	— C	
Size & Figure No.										Service	
1/2" - 6" (Full Port)										Chlorine	C
DN 15-150 (Full Port)										Oxygen	O
8" (Standard Port)										Vacuum	V
										General Service	Blank
										Other**	X
Flange Standard										Operator	
ASME Class 150	1									No Operator	N
EN PN16	2									Oval Handle	O
JIS 10Kg	3									Wrench with locking device	H
ASME Class 150 (Reduced Port)	4									Gear	G
										Gear with locking device	GX
										Actuator*	A
Face to Face										Seat & SX Seal	
ASME B16.10 Short Pattern	2									Chemically Modified PTFE (CMP)	P16
Long Pattern	3									Chemically Modified PTFE (CMP Antistatic)	P16AS
EN	4									UHMWPE	P8
Packing Options										Ball	
Adjustable	A									Standard Ball Duplex	28
										Stainless Steel Lined	
Body											
Ductile Iron	1										
Stainless Steel	6										
Other	X										
Liner											
PFA	P6										
PFA (anti-static)	P6AS										
PVDF	P9										



CRANE CHEMPHARMA & ENERGY

Xomox International GmbH & Co.OHG
Von-Behring-Straße 15
88131 Lindau (Bodensee)
Germany
Tel.: +49 8382 702-0

Xomox Corp.
4444 Cooper Road,
Cincinnati, OH 45242
USA
Tel.: (513) 745-6000

Crane Company, and its subsidiaries cannot accept responsibility for possible errors in catalogues, brochures, other printed materials, and website information. Crane Company reserves the right to alter its products without notice, including products already on order provided that such alteration can be made without changes being necessary in specifications already agreed. All trademarks in this material are the property of the Crane Company or its subsidiaries. The Crane and Crane brands logotype (ALOYCO®, BAUM®, CENTER LINE®, CRANE®, CRYOWORKS®, DEPA® & ELRO®, DOPAK®, DUO-CHEK®, FLOWSEAL®, GYROLOK®, GO REGULATOR®, HOKE®, JENKINS®, KROMBACH®, NOZ-CHEK®, PACIFIC®, RESISTOFLEX®, XOMOX®, SAUNDERS®, STOCKHAM®, TECHNIFAB®, TEXAS SAMPLING®, WESTLOCK CONTROLS®, WTA®, and XOMOX®) are registered trademarks of Crane Co. All rights reserved.