

XOMOX[®]

L-TORQ XOMOX[®]
SLEEVED PLUG
VALVES



OPERATING AND MAINTENANCE INSTRUCTIONS

Types L127; L067; L0367

CRANE[®]



www.cranecpe.com

General Information

INTRODUCTION

This information is provided to support the user with assembly, operation and maintenance of the L-TORQ XOMOX Valves (Types L127; L067; L0367). Please read the following instructions carefully before a valve is installed or operated.

ATTENTION

READ AND UNDERSTAND INSTRUCTIONS BEFORE SERVICING THE VALVE.

If instructions and warning notes in this manual are not adhered to, serious danger can arise, and warranty of the manufacturer could become void.

1. VALVE APPLICATION

Valves shall be installed between flanges in a piping system and are intended exclusively to let pass, shut off, or control the flow of fluids within the certified limits of pressure and temperature rating refer to the pressure-Temperature chart in the L-TORQ XOMOX valve brochure.

This is soft seated valve with PFA and not recommended for fluids having excess of 3% solid particulates, please consult factory for additional details.

2. SAFETY INFORMATION

2.1 General Safety Information

The same safety requirements apply for valves as for the piping system into which they are installed, and as for the plant control system, to which they are connected. Following instructions provide such advice only, which shall be observed additionally.

Separate safety information is included in the manual of the actuator attached to the valve.

ATTENTION

These valves should not be used in service conditions where materials of its parts in contact with the fluids are not suitable.

ATTENTION

Subsequent caution- and warning comments are not being adhered to, danger can result, and the guarantee of the manufacturer will become void. The manufacturer is at your disposal for further information – please see contact information on the last page.

2.2 Important information for the User

Before proceeding, please pay attention to the items presented in the beginning of this instruction manual and make sure that they are being followed in all following matters.

Please notice, that it is not the liability of the Valve Manufacturer to make sure that:

- the valve is only used following personal protective procedures and safety practices for protection as usual in the plant, into which the valve is installed.
- the valve is only used as specified in Section 1 “Valve Application”.
- an actuator for a valve supplied bare shaft has been sized and assembled to the valve according to the manufacturer’s recommendations.
- such an actuator has been adjusted correctly in the valve’s end positions – specifically in the OPEN end position.
- the design of the housing of the valve allows usual additional forces and bending torques, which are normal in such piping systems.
- the pipe system and the plant control system have been installed by experts and that these systems are regularly inspected.

General Information

- the fluid flow velocity in this pipe system is limited to the usual values, i.e. 4 m/s (13 ft/sec) for liquids, and no abnormal service conditions occur, such as vibrations, water hammer or cavitation.
- the contents of solid – especially hard and sharp – particulates in the fluid is known to and accepted by the manufacturer.
- valves used at fluid temperature $>50^{\circ}\text{C}$ (122°F) or $<-20^{\circ}\text{C}$ (-4°F) are protected together with the pipe connection ends from contact with the user.
- only trained and duly authorized personnel, who are trained in all aspects of plant safety – specifically for those fluids under pressure – shall operate, inspect and repair these valves.
- personnel shall read and understand the requirements of this manual.

ATTENTION

- **Only original L-TORQ XOMOX spare parts may be installed.**
- **Never reassemble with used cover gasket and stem packing.**
- **Clean components, stuffing box and stem to ensure that they are completely free of wear, solids or corrosion.**
- **Ensure that the gland, bolts and nuts run freely on threads**
- **Make sure that the gland follower nose is clean and fits properly into the stuffing box.**
- **Make sure that the plug stem has a surface finish of 32RMS Ra=0.8 or better and the stuffing box has a surface finish of 64RMS Ra=1.6 post cleaning.**
- **Obtain the correct equipment to setup packing described in this document.**
- **Refer to product literature for application data.**
- **Review all instructions below before proceeding with installation.**

2.3 Special kinds of danger

Make sure not to use thick elastomeric gaskets as this may lead to external leakage of the valve. The gasket used shall support and overlap the mating flange surface of the valve at both sides completely.

ATTENTION

- **Before a valve is removed from the pipe or the sleeve cartridge kit from the valve body is disassembled, make sure that the media in the pipe system is completely depressurized.**
- **During maintenance and cartridge replacement, it is recommended to depressurize the plug top area by adjusting the plug to the bottom most level with simple rotation of adjustment nut. Refer to plug adjustment guidance in this document.**
- **Valves in end-of-line-position:**
 - **For normal service a valve shall be used only, if a blind flange is assembled downstream (unless otherwise noted on the valve).**
 - **If a valve used in end-of-line-position shall be opened under pressure, open the valve very carefully: The fluid can splash out with high velocity.**
- **If a valve shall be removed from the pipeline:**
 - **Make sure that the pipe system is completely drained before the valve is removed from the pipeline. Be extra careful of residual amounts of the fluid that may remain trapped in the valve and/or in the pipeline.**

Introduction

ABOUT CRANE XOMOX

Xomox International is a world leader in the manufacturing of Sleeved Plug Valves that continues to strive for best-in-class solutions to our customers.

Today, we have widened our product portfolio so that our customer can comply with stringent emission requirements and handle complex applications such as phosgene, chlorine, and HF derivatives.

Trouble-free operation

XOMOX® valves have proven themselves with long term, trouble-free service in a wide variety of applications.

When applied within their pressure and temperature limitations, properly installed, adjusted and operated, these valves should require minimum attention and lower your long term ownership costs.

In case there are any questions, please contact your Crane ChemPharma & Energy representative, or the factory. Contact information can be found in the last page of this manual.

IMPORTANT INFORMATION

Read carefully

The following information, procedures and illustrations have been prepared to assist the user in assembly, installation and operation of L-TORQ XOMOX Sleeve Plug Valves. Please read and make sure to fully understand these instructions.



L-TORQ XOMOX Sleeved Plug Valves
Patent Pending

Plug Adjustment

Valve tightness can be set by lifting the plug, which increases the dynamic seal compression. The adjustment does not need special tooling and can be done in-line on manual or actuated valves by rotating the adjustment nut with an open-end wrench tool. The plug height position should be set so that the valve reaches the required in-line sealing at the lowest plug rotation torque to maximize the valve lifetime.

The operator should loosen the grub screw. The adjustment nut has left-handed threads. (Thread pitch is 1.5mm). The adjustment nut rotates clockwise lifting the plug, increasing the sealing force and eliminates or reduces leakage. The lifting of the plug increases the valve torque. An adjustment should be made by a maximum of 60-90 (insert degree sign) rotation, and after adjustment the operator should check the valves in-line sealing and torque. The valve torque should not exceed 20% of the published break torque.

The adjustment nut thread is then locked in place with a grub screw in the gland. After adjustment the operator should check that the adjustment nut does not rotate together with the plug stem. In this case the operator should re-tighten the grub screw.

The adjustment nut counterclockwise rotation pushes down the plug and reduces the valve torque, but larger adjustment may cause inline leakage

Adjustment nut

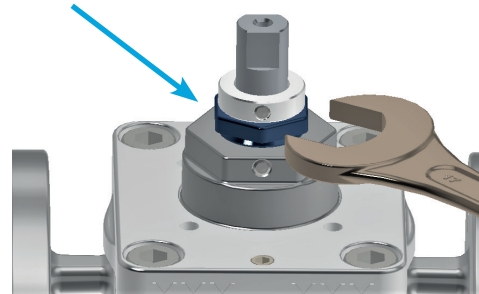

Gland – hold with wrench

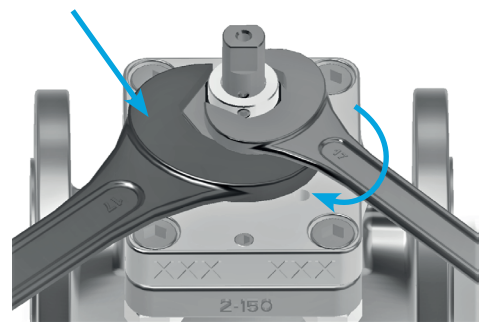

Grub screw for adjustment nut thread locking

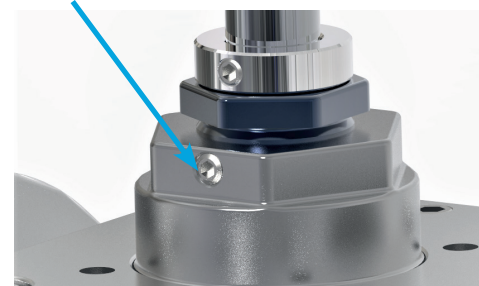

SIZE		Wrench size [mm]
NPS	DN	
1/2"	DN 15	24
3/4"	DN 20	24
1"	DN 25	30
1 1/2"	DN 40	30
2"	DN 50	30
3"	DN 80	30
4"	DN 100	46
6"	DN 150	50

Stem Packing Adjustment

Due to stem packing relaxation and wear, the gland torque should be checked and if necessary, re-tightened with the required torque (see below table) during regular checks and maintenance.

The valve stem packing can be resealed by re-tightening the threaded gland. The gland re-tightening can be done in-line on manual or actuated valves by rotating the gland clockwise with a Crows Foot tool.

For the proper stem packing compression, the operator should use the required Crows Foot and tightening torque based on the below table.

After gland tightening, open and close the valve 3 times for consolidation of the stem packing and re-tighten the gland with the to the same torque. Repeat this process until you do not notice any loss of torque value.

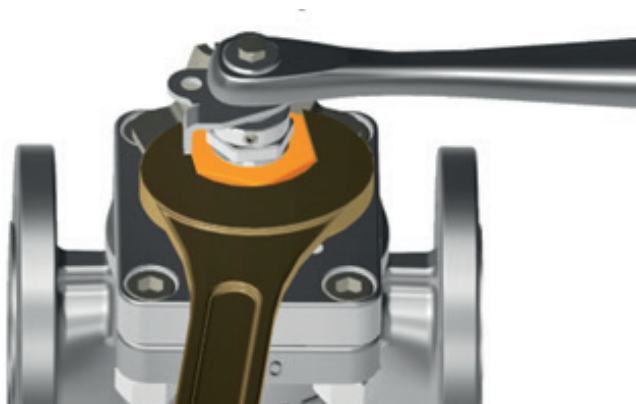

SIZE		Wrench size [mm]	Gland tightening torque [Nm]	
NPS	DN		PTFE	Graphite
1/2"	DN 15	32	28	68
3/4"	DN 20	32	28	68
1"	DN 25	41	28	68
1 1/2"	DN 40	46	89	212
2"	DN 50	46	89	212
3"	DN 80	46	89	212
4"	DN 100	60	210	497
6"	DN 150	65	255	604

Sleeve Cartridge Kit Replacement

PROCESS STEPS

1. Confirm the valve is depressurized and the media is completely released from the valve.
2. Remove the hand lever with the stopper or the actuator with the bracket
3. Remove the cover bolts
 - First remove only 3 cover bolts, loosen the remaining one and drive the nut to the lowest position on the bolt that can keep the cartridge kit in the body if any residual pressure remains in the valve or under the plug
4. Drive the cover grub screws to lift the kit
5. Use both screws alternately to lift the cartridge kit
6. Remove the remaining cover bolt and nut
7. Pull the cartridge kit out from the body
8. Remove the cover gasket
9. Clean the internal surfaces of the body
10. Put a new cover gasket into the body
11. Push the new kit into the body
12. Put the cover bolts into the cover
13. Tightening the nuts
 - use proper tightening sequences
 - bolts tightening torque based on below table.
14. Set the plug height with the adjustment nut rotation
 - See previous Plug Adjustment chapter
15. Tighten the gland with the required torque.
 - See detailed information about Stem Packing Adjustment at previous page
16. Assemble back the hand lever or the actuator

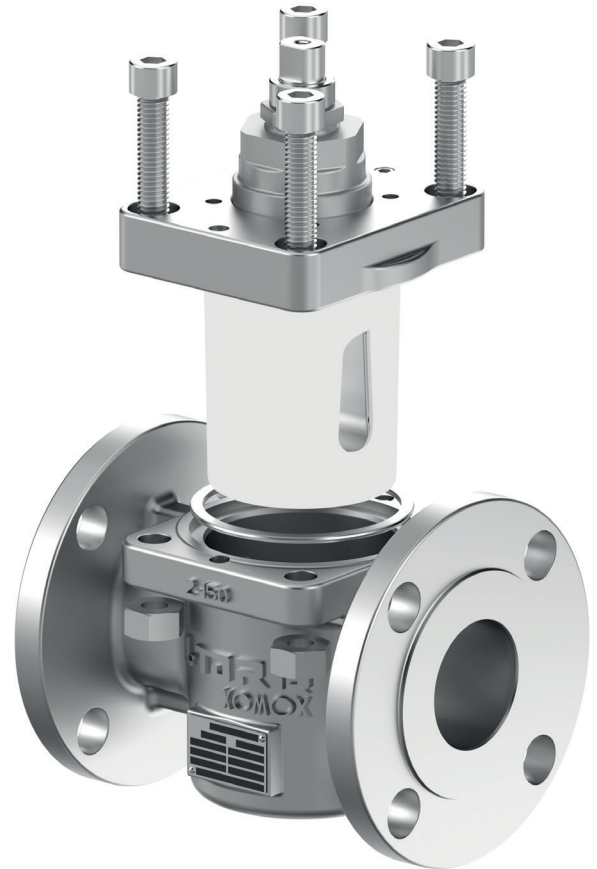

NPS	DN	Cover Bolt Spec	Cover Bolt Material	Bolt Size	MIN Torque [Nm]	MAX Torque [Nm]
1/2"	DN 15	SOCKET HEAD HEX BOLT M8-1.25Px35 mm LONG	A4-70	M8	14	16
3/4"	DN 20	SOCKET HEAD HEX BOLT M8-1.25Px35 mm LONG	A4-70	M8	14	16
1"	DN 25	SOCKET HEAD HEX BOLT M8-1.25Px40 mm LONG	A4-70	M8	14	16
1 1/2"	DN 40	SOCKET HEAD HEX BOLT M10-1.5Px45 mm LONG	A4-70	M10	27	33
2"	DN 50	SOCKET HEAD HEX BOLT M12-1.75Px50 mm LONG	A4-70	M12	48	57
3"	DN 80	SOCKET HEAD HEX BOLT M14-2Px50 mm LONG	A4-70	M14	76	91
4"	DN 100	SOCKET HEAD HEX BOLT M16-2Px60 mm LONG	A4-70	M16	118	142
6"	DN 150	SOCKET HEAD HEX BOLT M20-2.5Px70 mm LONG	A4-70	M20	231	277

CRANE[®]

CRANE CHEMPHARMA & ENERGY

Xomox International GmbH & Co.OHG
Von-Behring-Straße 15
88131 Lindau (Bodensee)
Germany
Tel.: +49 8382 702-0

Xomox Corp.
4444 Cooper Road,
Cincinnati, OH 45242
USA
Tel.: (513) 745-6000

Crane Company, and its subsidiaries cannot accept responsibility for possible errors in catalogues, brochures, other printed materials, and website information. Crane Company reserves the right to alter its products without notice, including products already on order provided that such alteration can be made without changes being necessary in specifications already agreed. All trademarks in this material are the property of the Crane Company or its subsidiaries. The Crane and Crane brands logotype (ALOYCO[®], BAUM[®], CENTER LINE[®], CRANE[®], CRYOWORKS[®], DEPA[®]& ELRO[®], DOPAK[®], DUO-CHEK[®], FLOWSEAL[®], GYROLOK[®], GO REGULATOR[®], HOKE[®], JENKINS[®], KROMBACH[®], NOZ-CHEK[®], PACIFIC[®], RESISTOFLEX[®], XOMOX[®], SAUNDERS[®], STOCKHAM[®], TECHNIFAB[®], TEXAS SAMPLING[®], WESTLOCK CONTROLS[®], WTA[®], and XOMOX[®]) are registered trademarks of Crane Company. All rights reserved.