

XOMOX®



L-TORQ XOMOX® SLEEVED PLUG VALVES

MOST COMPACT
AUTOMATED SPV
PACKAGES IN THE
INDUSTRY

CRANE



www.cranecpe.com

Why XOMOX® Plug Valves

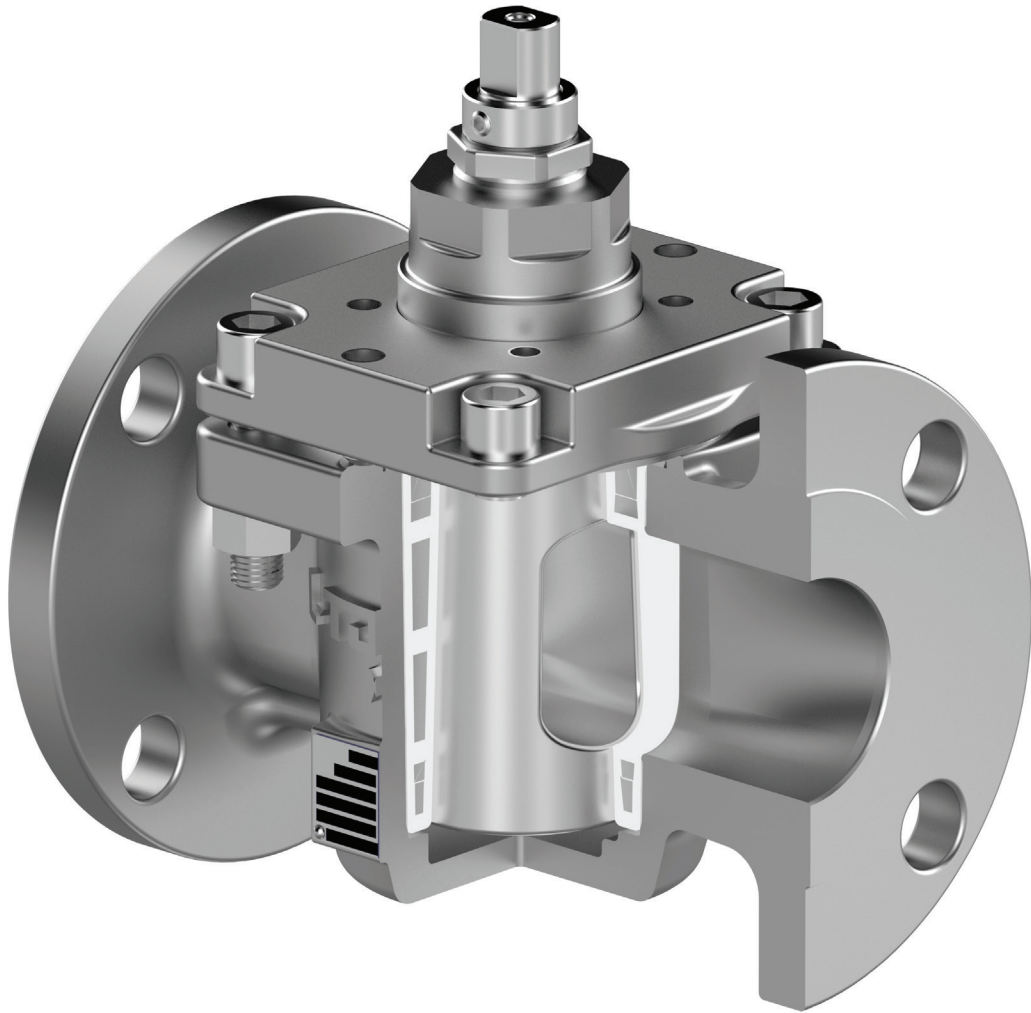

No Cavities

No scaling media
– Torque does not increase during service

Large Sealing Area

Small scratches do not affect the seal. No concern of leakage

Inline Adjustable

Inline and external seals can be adjusted while the valve is installed.

Product Overview

Materials of Construction

- WCB/CF8M/CN7M/CD4MCuN with PFA Cartridge
- 1.069/1.4408/1.4500/1.4470 Duplex with PFA Cartridge

Size Range

- ½" - 6"
- DN15 - DN150

Pressure Ratings

- ASME Class 150, 300
- EN Class PN 10-40

Sealing and Packing

- Cover Joint: 50% PTFE - 50% Graphite Spiral Wound Gasket with Monel or SS trim.
- Stem Seals: PTFE or Graphite

Actuator Mounting

- ISO 5211 Mounting

Applications

- MDI, TDI
- Fertilizer
- Ammonia
- Caustic
- Crude
- Oil Sands
- AA
- Chlorine
- HCN
- Sulfuric Acid
- HF
- Coffee



L-TORQ XOMOX

Brings remarkable benefits in torque, reparability and emissions performance, while maintaining the primary properties of a sleeved plug valve.

Features and Benefits

50% ↓

 **TORQUE REDUCTION**

**Conventional
Sleeved Plug Valve**

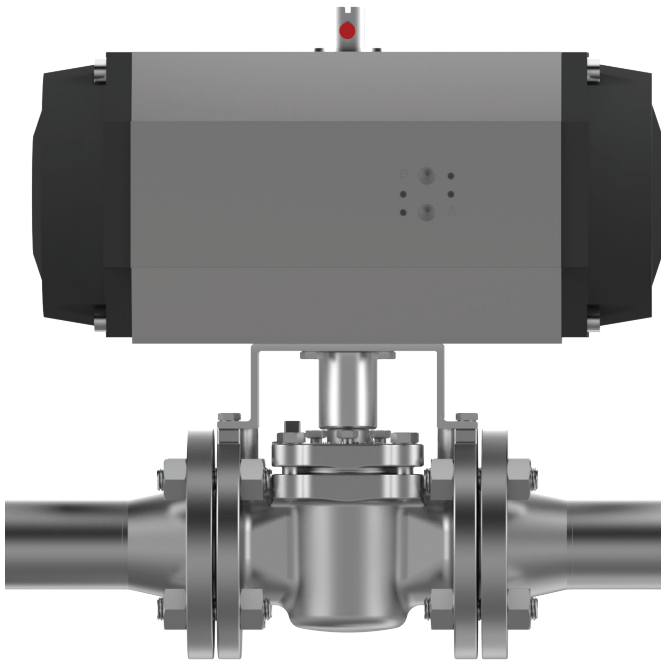

L-TORQ



Smaller Actuator

Lighter Weight
(Actuated Valves)

Longer Lifetime

Features and Benefits



SIMPLIFIED REPAIR

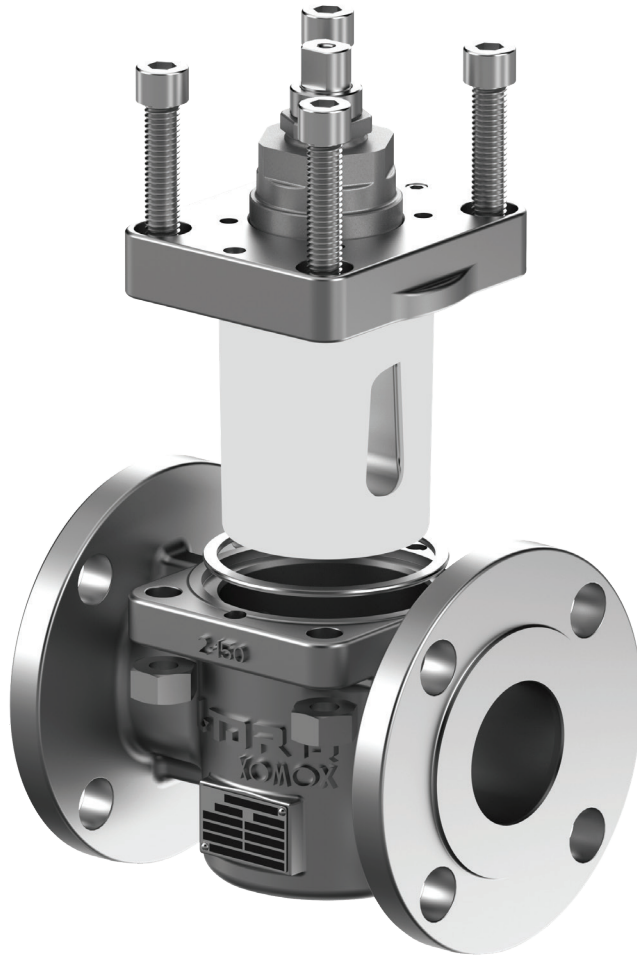

**Simplified
Repair**

**Compact Sleeve
cartridge design**

**Cover, Plug
and Sleeve Cartridge
Separate components**

Features and Benefits



FUGITIVE EMISSIONS

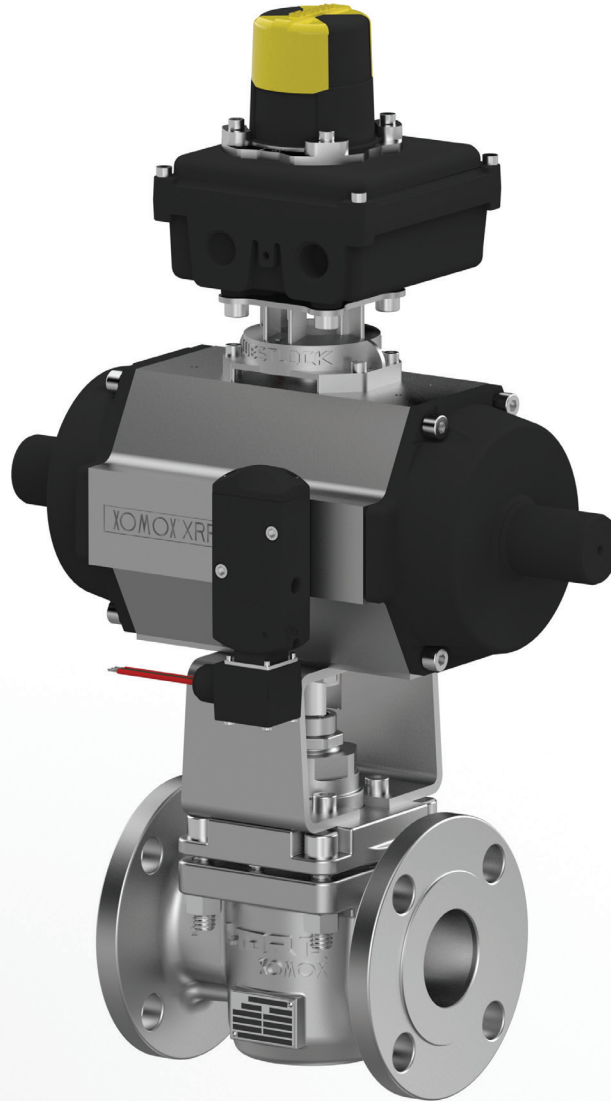

ISO 15848-1
2015

TA-LUFT
2021

ANSI/API
STD 607
8th EDITION 2022

Design Features

SLEEVE CARTRIDGE DESIGN

- Structure that supports the sleeve by giving more dimensional control.
- Fully encapsulated metal cage port lips in PFA – eliminating the crevice region that exist in conventional SPV design



INVERTED PLUG

- Provides effective control on sleeve compression
- Plug adjustment done by plug lifting
- Separated stem packing and plug adjustment



REPAIR KIT

- Compact sleeve cartridge design
- This simplified repair process does not require highly skilled personnel nor special tooling.



Overview

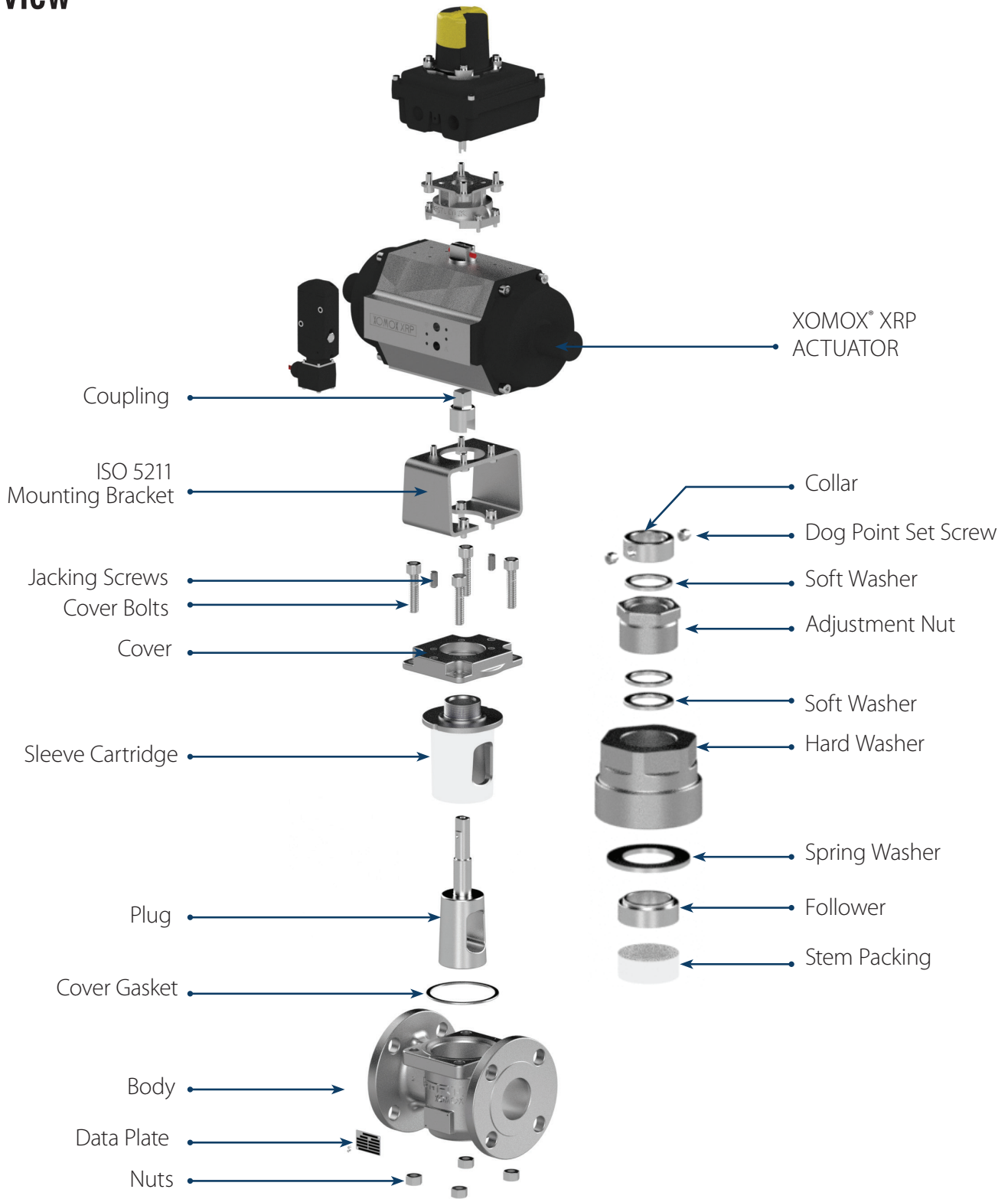

Design Features and Options

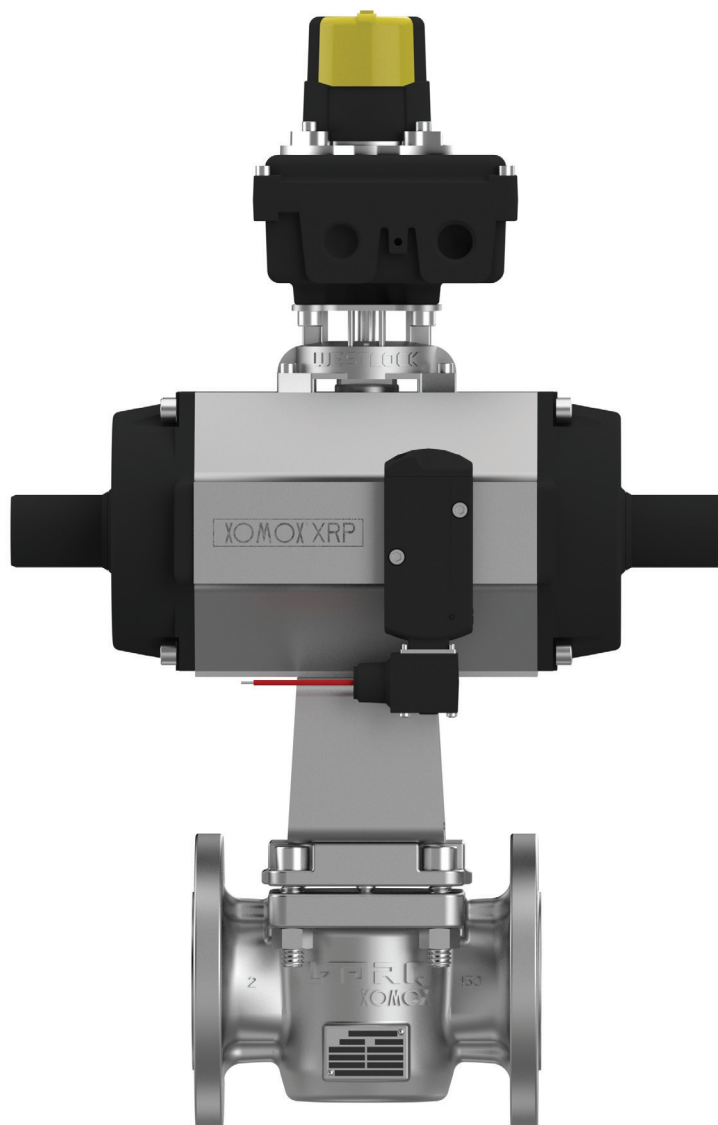

**ISO 5211
Actuator
Mounting**

**Locking Device
as standard with
Lever And Gear
Operators**

**Automated
Packages with
NAMUR interface
readily available**

**Available in
Firesafe
Option
as per API 607**

Pressure Temperature Ratings ANSI

PRESSURE-TEMPERATURE RATING

L-TORQ XOMOX FIG. L067 & L0367, SIZE 1/2"-6" 2-WAY, CLASS 150 & 300

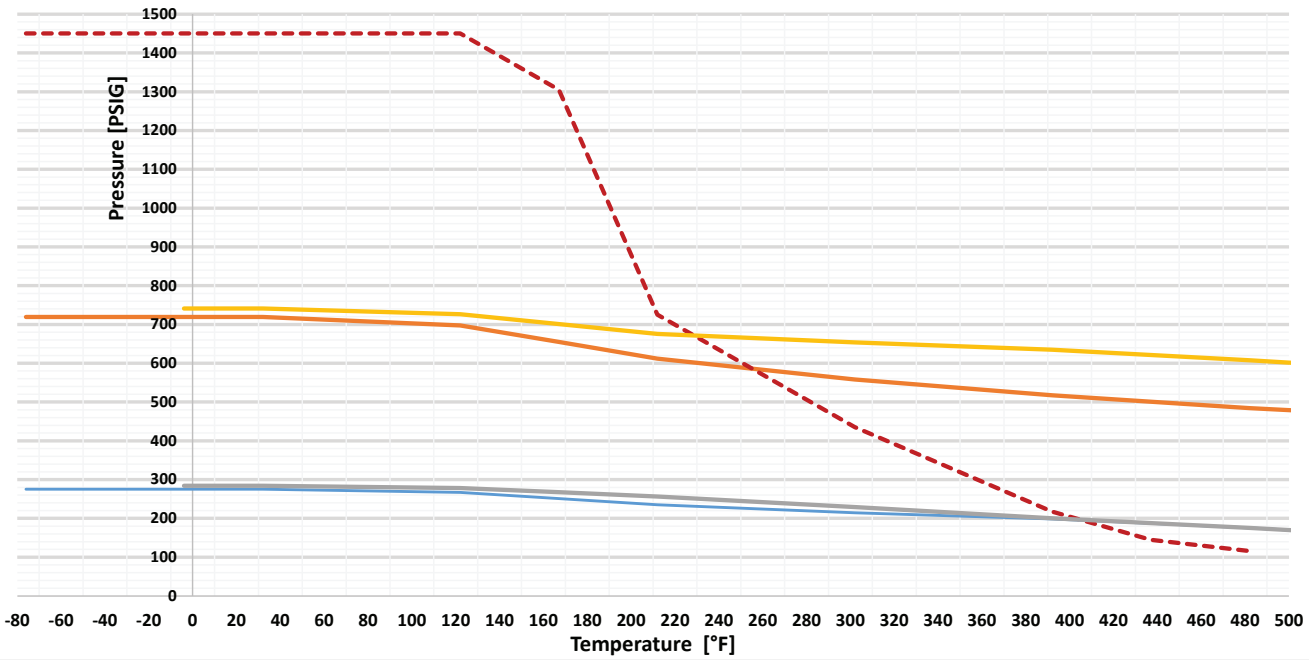

OPERATING TORQUES. (INCH-POUNDS)

Size	Break Torque	Seat Torque	Run Torque
1/2"	70	80	71
3/4"	70	80	71
1"	190	151	133
1½"	400	319	284
2"	545	434	381
3"	660	532	461
4"	1,350	1,080	948
6"	2,700	2,169	1,877

* Figures are for 2-Way valves with PFA Cartridge for clean media. For Chlorine, Oxygen etc. Dry Built configurations multiply the above values with 1.5

Pressure Temperature Ratings DIN

PRESSURE-TEMPERATURE RATING

L-TORQ XOMOX FIG. L067 & L0367, SIZE DN15 to DN150 2-WAY, PN 16 and PN40

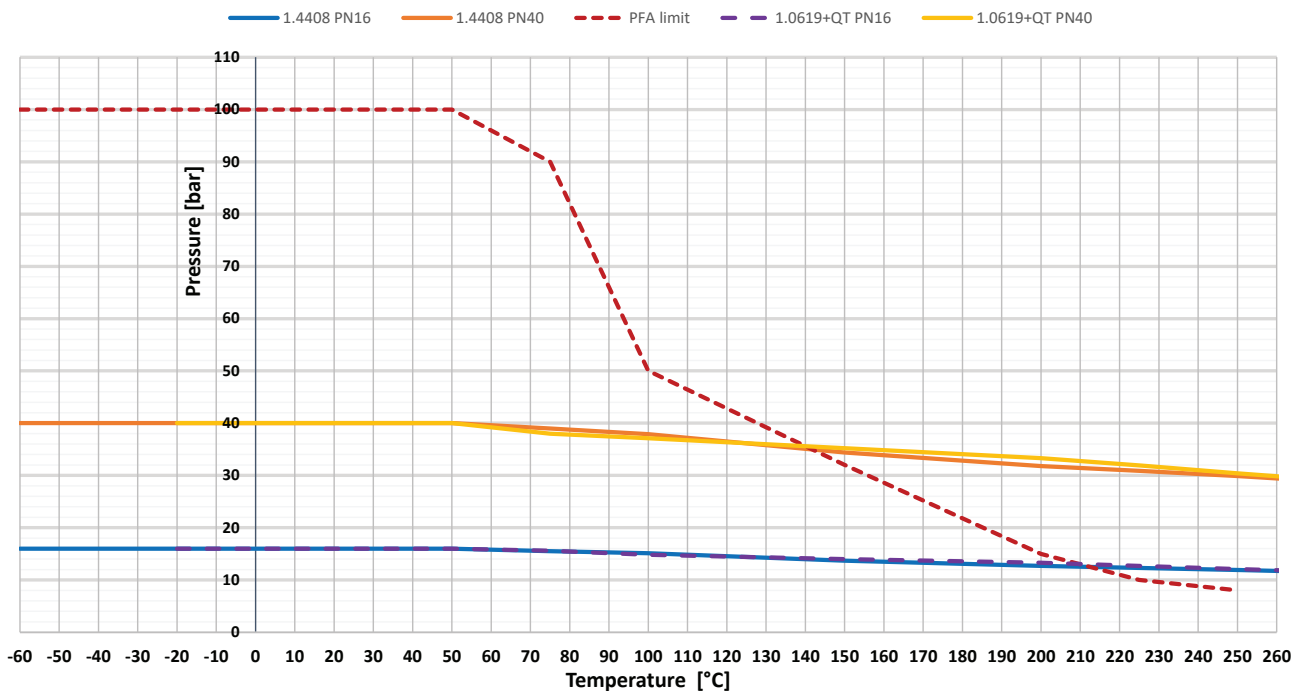

OPERATING TORQUES. (NM)

Size	Break Torque	Seat Torque	Run Torque
1/2"	8	9	8
3/4"	8	9	8
1"	21	17	15
1½"	45	36	32
2"	62	49	43
3"	75	60	52
4"	153	122	107
6"	305	245	212

* Figures are for 2-Way valves with PFA Cartridge for clean media. For Chlorine, Oxygen etc. Dry Built configurations multiply the above values with 1.5

MAST and Kv/Cv Values for US and EU

L-TORQ MAST (ANSI/DIN)

Size		1.4408/CF8M	1.4470 (Duplex) / CD4MCuN
1/2"	DN 15	62	96
3/4"	DN 20	62	96
1"	DN 25	107	164
1 1/2"	DN 40	222	343
2"	DN 50	222	343
2 1/2"	DN 65	222	343
3"	DN 80	222	343
4"	DN 100	576	892
5"	DN 125	852	1318
6"	DN 150	852	1318

Kv / Cv Values L067 class 150 & L0367 class 300

ANSI		
	KV	CV
1/2"	14	16
3/4"	16	19
1"	45	52
1 1/2"	101	117
2"	186	215
3"	306	354
4"	538	622
6"	1066	1232

Kv / Cv Values L127 PN10-40

DIN		
	KV	CV
DN 15	14	16
DN 20	16	19
DN 25	47	54
DN 32	47	54
DN 40	103	119
DN 50	190	220
DN 65	190	220
DN 80	350	405
DN100	615	711
DN125	615	711
DN150 SHORT	1066	1232
DN150 LONG	1109	1282

Ltorq Data Plate



L-TORQ XOMOX

L-TORQ XOMOX® brings remarkable benefits in torque, reparability, and emissions performance, while maintaining the primary properties of a sleeved plug valve; 50% lower torque than current sleeved plug valves, replaceable cartridge design that equates to less costs, and it Meets the new TA-LUFT & ISO-15848 standards.

Contact Us

- FEATURES AND BENEFITS
- TECHNICAL DETAILS
- APPLICATIONS
- LITERATURE
- CERTIFICATES

L-TORQ web page QR code

Data matrix for serial number



CraneCPE.com
"Made In" Country of Origin

Figure No ISO FE	
Size/Class	
Break Torque	
Body Matl/Cart Seal Matl/Stem Packing Matl	
CE # / Manufacturing year	
Max Temp/Max pressure at that temp (TS)	
Max pressure/Max temp at that pressure (PS)	
Valve Part #	
Valve Serial #	

L-TORQ Data Plate

ISO 15848 (TA-LUFT 2021) Standard Introduction



International Organization for Standardization

INTERNATIONALISO STANDARD 15848-1

ISO 15848-1 is an International standard for fugitive emissions issued by the ISO Organization. It contains both dynamic life cycles and thermal cycles and is considered one of the most demanding fugitive emission standards for soft seated valves. This standard contains different levels of acceptance based on the number of thermal and mechanical cycles, temperature, and number of adjustments. The objective of ISO 15848-1 is to enable classification of performance in different designs and constructions of valves to reduce fugitive emissions.

Example Description Tables

ISO 15848 – 1 BH CO3 392°F – SSA0

Part Composition		Number of Adjustments	
Part 1: Design • System of classification and procedures of qualification for the tests of the valve type	Part 2: Industrial (Production) • Acceptance tests in production of the valves • Non-destructive	0 / 1 / 2 / 3	

Temperature Classes				
(T-196°C)	(T-40°C)	(T RT)	(T200°C)	(T400°C)
-320°F	-40°F	Room temperature, °F	392°F	752°F
-196°C	-40°C	Room temperature, °C	200°C	400°C

Classification	Minimum number of mechanical cycles
CO1	800 cycles, with two thermal cycles (except for RT)
CO2	1,500 cycles, with three thermal cycles
CO3	2,500 cycles, with four thermal cycles

Test Fluid	Class
H - Helium	AH, BH, CH
M - Methane	AM, BM, CM

When the test fluid is **helium**, classes are identified as AH, BH and CH.
When the test fluid is methane, classes are identified as AM, BM and CM.

Class	Measured Leak Rate ^a mg s ⁻¹ m ⁻¹	Remarks
A ^b	≤ 10 ⁻⁵	Typically achieved with bellow seals or and equivalent stem (shaft) sealing system for quarter turn valves
B	≤ 10 ⁻⁴	Typically achieved with PTFE based packings or elastomeric seals
C	≤ 10 ⁻²	Typically achieved with flexible graphite based packings

^a Expressed in mg s⁻¹ m⁻¹ measured with total leakage method
^b Class A can be measured only with helium using the vacuum method

Manufacturing valves will be subjected to the ISO 15848-2 test as described in the norm. This is a non-destructive test that intends to address the performance of the valves (Please refer to ISO 15848 norm).

How to Order

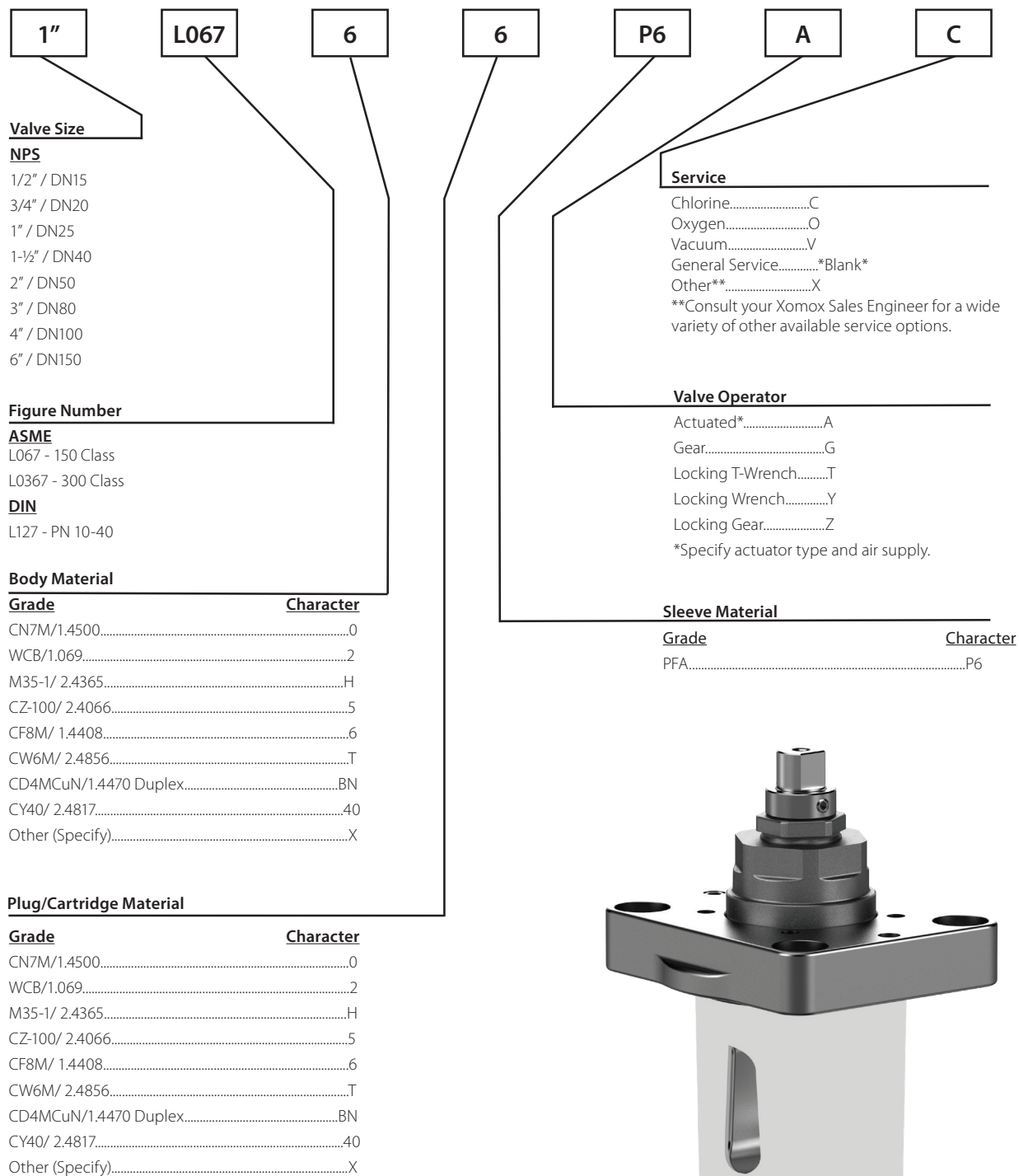

* For ordering Spare kit, please contact XOMOX Sales Representative.

* Other ferrous/non-ferrous material consult XOMOX engineer

CRANE®

CRANE CHEMPHARMA & ENERGY

Xomox International GmbH & Co.OHG
Von-Behring-Straße 15
88131 Lindau (Bodensee)
Germany
Tel.: +49 8382 702-0

Xomox Corp.
4444 Cooper Road,
Cincinnati, OH 45242
USA
Tel.: (513) 745-6000

Crane Company, and its subsidiaries cannot accept responsibility for possible errors in catalogues, brochures, other printed materials, and website information. Crane Company reserves the right to alter its products without notice, including products already on order provided that such alteration can be made without changes being necessary in specifications already agreed. All trademarks in this material are the property of the Crane Company or its subsidiaries. The Crane and Crane brands logotype (ALOYCO®, BAUM®, CENTER LINE®, CRANE®, CRYOWORKS®, DEPA®& ELRO®, DOPAK®, DUO-CHEK®, FLOWSEAL®, GYROLOK®, GO REGULATOR®, HOKE®, JENKINS®, KROMBACH®, NOZ-CHEK®, PACIFIC®, RESISTOFLEX®, XOMOX®, SAUNDERS®, STOCKHAM®, TECHNIFAB®, TEXAS SAMPLING®, WESTLOCK CONTROLS®, WTA®, and XOMOX®) are registered trademarks of Crane Company. All rights reserved.