

XOMOX[®]

L-TORQ XOMOX[®]
SLEEVED PLUG
VALVES



**TECHNICAL
DATASHEET**
ASME DESIGN

CRANE[®]

v in

www.cranecpe.com

Product Overview

L-TORQ XOMOX Sleeved Plug Valves

L-TORQ XOMOX brings remarkable benefits in torque, reparability and emissions performance, while maintaining the primary properties of a sleeved plug valve:

- Significant torque reduction and cost-effective automation package
- Complete cartridge kit for ease of repair
- In-line valve repair for maintenance, reducing downtime
- Independent plug adjustment and adjustable stem packing
- Designed to meet the latest Fugitive Emission Compliance according to ISO 15848-1

STANDARD FEATURES INCLUDE:

- Material of construction: WCB, CF8M, CN7M, CD4
- Automation packages: XRP, Matryx, Westlock limit switch, positioner
- Sealing and Packing:
 - Cover Joint: 50% PTFE - 50% Graphite Spiral Wound Gasket with Monel or SS trim
 - Stem Seals: PTFE or Graphite
- Actuator Mounting: ISO 5211 mounting
- Fugitive emissions:
 - New TA-Luft
 - ISO 15848-1 BH CO3 200°C SSA0 Standard

OPTIONAL FEATURES INCLUDE:

- Material of construction: M35-1, CW6M, CZ100 and other alloys
- Partial jackets
- Firesafe
- JIS standard



Product Range

SIZE	CLASS	BODY DESIGN	FACE-TO-FACE DIMENSION	BODY MATERIAL
1/2"-6"	Class 150, 300	Flanged	ASME B16.10	WCB CF8M

Exploded View and Materials of Construction

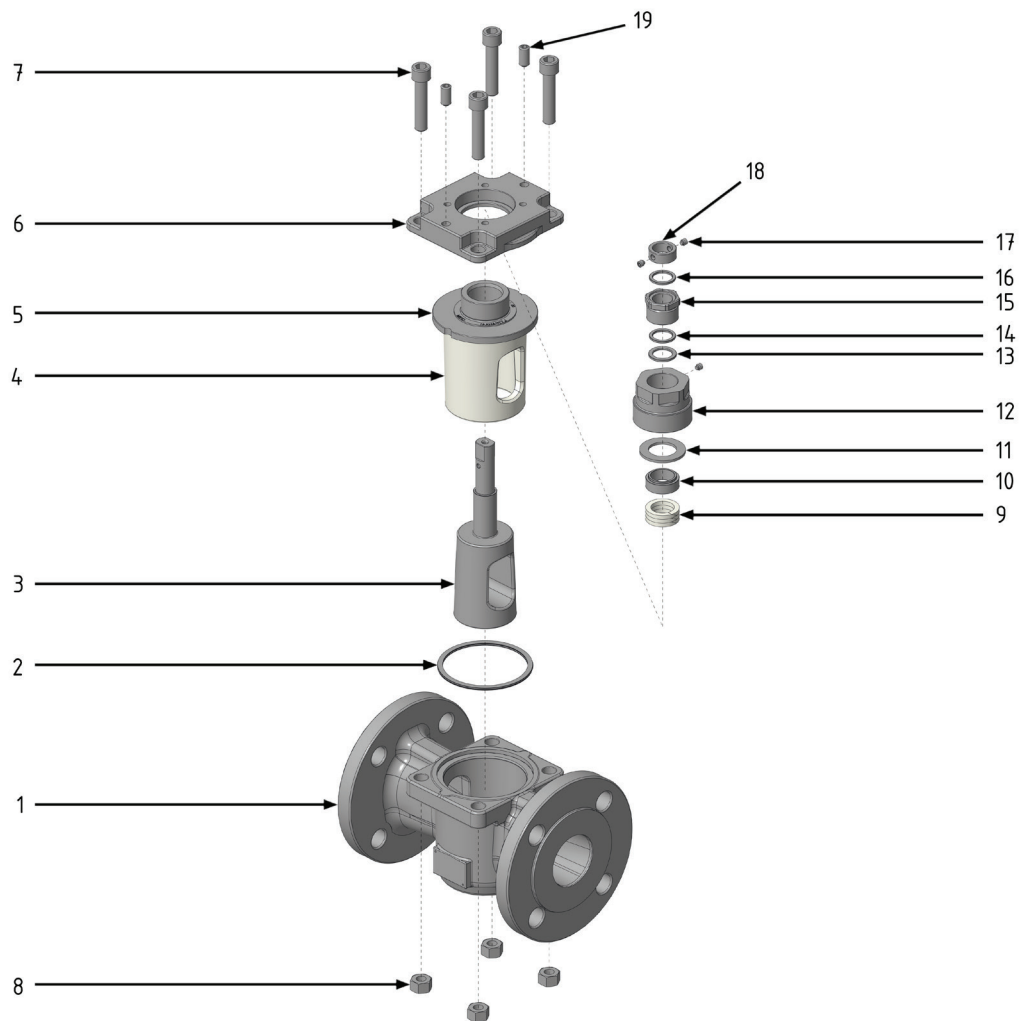

ITEM	DESCRIPTION	CARBON STEEL		STAINLESS STEEL	
		ASTM	DIN	ASTM	DIN
1	Body	A216 WCB	1.0619+QT	A351 CF8M	1.4408
2	Body-Cover Gasket	316L SS, PTFE/Graphite Blend (Donnit MS10T)			
3	Plug	A351 CF8M	1.4408	A351 CF8M	1.4408
4	Molded Sleeve	PFA			
5	Sleeve Cartridge	ASTM A351 CF8M & DIN 1.4408			
6	Cover	A216 WCB	1.0619+QT	A351 CF8M	1.4408
7	Cover Bolts	ISO 3506-1 A4-70			
8	Cover Nuts	ISO 3506-1 A4-70			
9	Stem Packing	PTFE (Latty 3265 LM) or Graphite (Chesterton 1622)			
10	Packing Follower	316 SS			
11	Belleville Washer	17-7PH SS			
12	Gland	ASTM A351 CF8M			
13	Hard Washer	17-4PH SS			
14	Soft Washer	CuNi14Al3			
15	Adjustment Nut	1.4470 CD3MN			
16	Soft Washer	CuNi14Al3			
17	Dog Point Screw	18-8 SS			
18	Collar	321 SS			
19	Jacking Screw	18-8 SS			

Dimensions and Weights

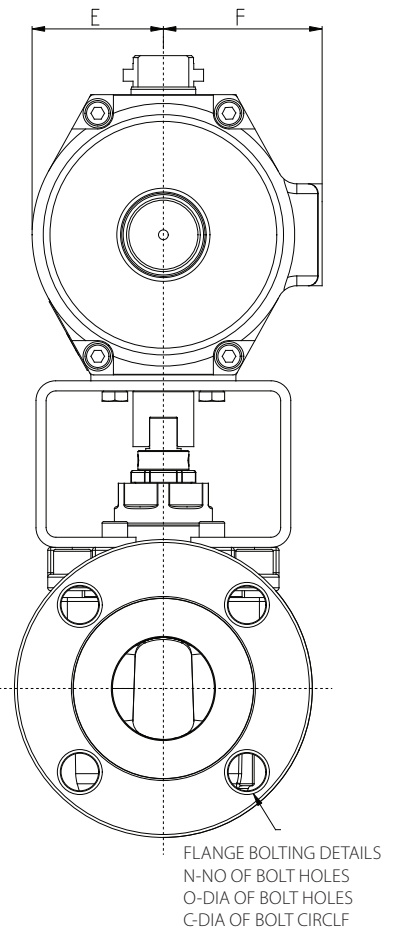
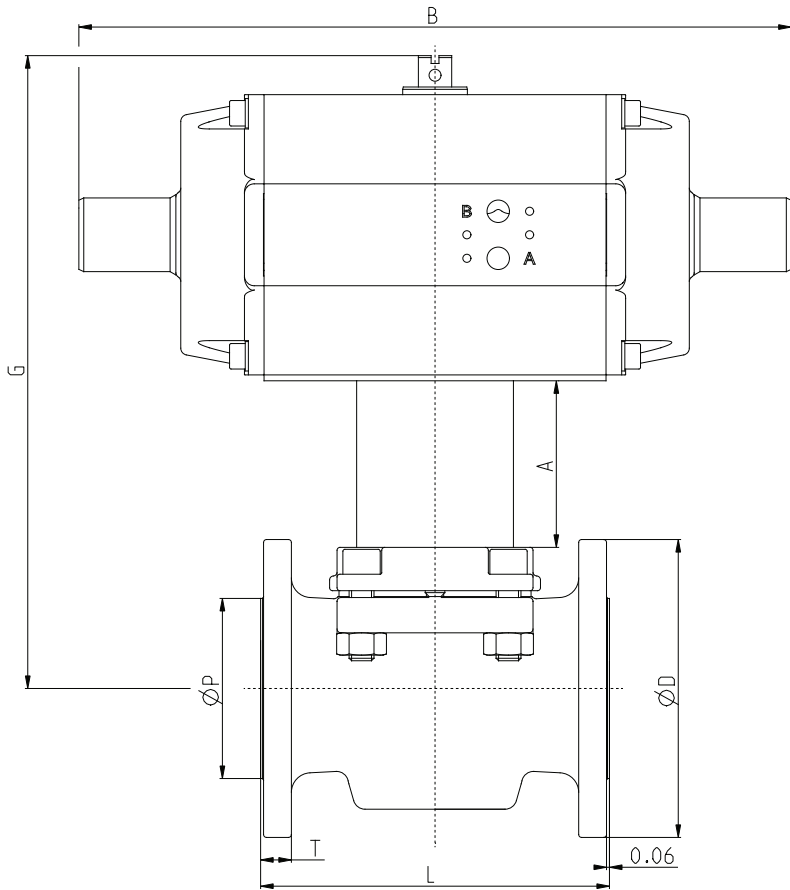

L-TORQ XOMOX FIG. L067 & L0367

Single Acting - Class 150 & 300

Single Acting with 80 PSIG air supply

L-TORQ XOMOX FIG. L067 & L0367, SIZE 1/2"-6", Class 150 and 300

SIZE		CLASS	DIMENSIONS (inch)											WEIGHT (lbs)	
			A	B	C	D	E	F	G	L	N	O	P		T
1/2"	DN 15	150	2.52	7.77	2.38	3.50	1.37	1.63	7.83	4.25	4	0.63	1.38	0.37	9.5
3/4"	DN 20	150	2.52	7.77	2.75	3.90	1.37	1.63	7.83	4.61	4	0.63	1.69	0.40	10.4
1"	DN 25	150	2.60	10.27	3.12	4.25	1.61	2.19	8.90	5.00	4	0.63	2.00	0.44	17.2
1 1/2"	DN 40	150	3.35	11.34	3.88	5.00	2.17	2.72	11.34	6.50	4	0.63	2.87	0.56	27.1
2"	DN 50	150	3.35	14.31	4.75	5.98	2.64	3.19	12.71	7.01	4	0.75	3.62	0.62	42.3
3"	DN 80	150	3.35	14.31	6.00	7.48	2.64	3.19	13.26	7.99	4	0.75	5.00	0.75	58
4"	DN 100	150	4.13	17.78	7.50	9.02	3.07	3.78	16.07	9.02	8	0.75	6.19	0.94	99
6"	DN 150	150	4.33	20.83	9.50	10.98	3.54	4.02	18.63	10.51	8	0.88	8.50	1.00	167.1
1/2"	DN 15	300	2.52	7.77	2.62	3.74	1.37	1.63	7.83	5.51	4	0.63	1.38	0.56	11
3/4"	DN 20	300	2.52	7.77	3.25	4.61	1.37	1.63	7.83	5.98	4	0.75	1.69	0.62	13
1"	DN 25	300	2.60	10.27	3.50	4.88	1.61	2.19	8.90	6.26	4	0.75	2.00	0.68	20.7
1 1/2"	DN 40	300	3.35	11.34	4.50	6.10	2.17	2.72	11.34	7.48	4	0.88	2.87	0.81	34.2
2"	DN 50	300	3.35	14.31	5.00	6.50	2.64	3.19	12.71	8.50	4	0.75	3.62	0.87	49.2
3"	DN 80	300	3.35	14.31	6.62	8.27	2.64	3.19	13.26	11.10	4	0.88	5.00	1.12	73.4
4"	DN 100	300	4.13	17.78	7.88	10.00	3.07	3.78	16.07	12.01	8	0.88	6.19	1.25	123.9
6"	DN 150	300	4.33	20.83	10.62	12.52	3.54	4.02	18.63	15.87	8	0.88	8.50	1.44	223.1

L-TORQ XOMOX FIG. L067 & L0367, SIZE 1/2"-6", Class 150 and 300

SIZE		CLASS	DIMENSIONS (mm)											WEIGHT (kg)	
			A	B	C	D	E	F	G	L	N	O	P		T
1/2"	DN 15	150	64	197	60	89	35	41	199	108	102	16	35	9	4
3/4"	DN 20	150	64	197	70	99	35	41	199	117	102	16	43	10	5
1"	DN 25	150	66	261	79	108	41	56	226	127	102	16	51	11	8
1 1/2"	DN 40	150	85	288	99	127	55	69	288	165	102	16	73	14	12
2"	DN 50	150	85	363	121	152	67	81	323	178	102	19	92	16	19
3"	DN 80	150	85	363	152	190	67	81	337	203	102	19	127	19	26
4"	DN 100	150	105	452	191	229	78	96	408	229	203	19	157	24	45
6"	DN 150	150	110	529	241	279	90	102	473	267	203	22	216	25	76
1/2"	DN 15	300	64	197	67	95	35	41	199	140	102	16	35	14	5
3/4"	DN 20	300	64	197	83	117	35	41	199	152	102	19	43	16	6
1"	DN 25	300	66	261	89	124	41	56	226	159	102	19	51	17	9
1 1/2"	DN 40	300	85	288	114	155	55	69	288	190	102	22	73	21	16
2"	DN 50	300	85	363	127	165	67	81	323	216	102	19	92	22	22
3"	DN 80	300	85	363	168	210	67	81	337	282	102	22	127	28	33
4"	DN 100	300	105	452	200	254	78	96	408	305	203	22	157	32	56
6"	DN 150	300	110	529	270	318	90	102	473	403	203	22	216	37	101

Dimensions and Weights

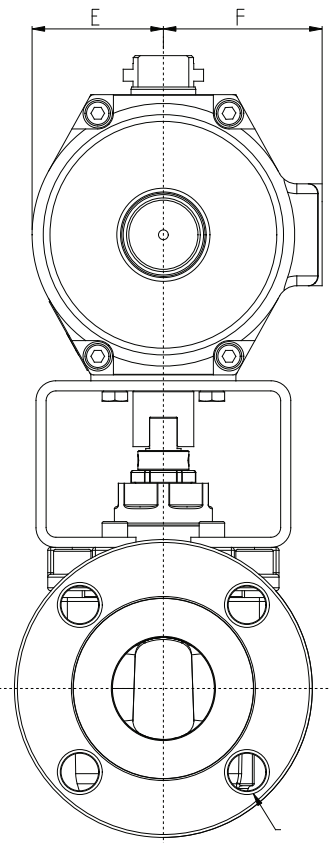
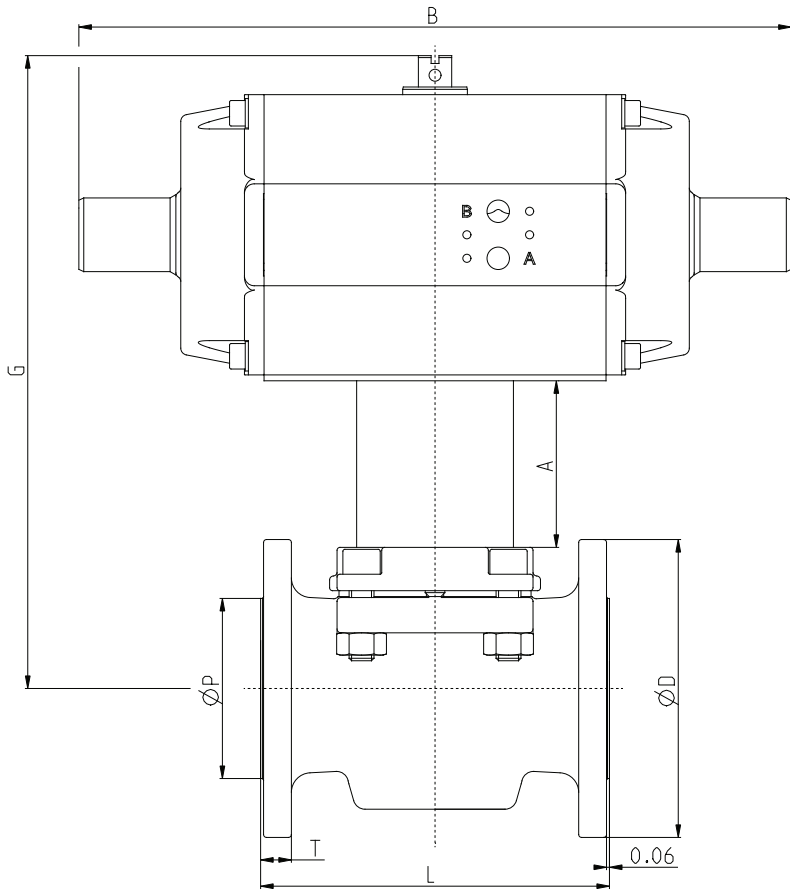

FLANGE BOLTING DETAILS
 N-NO OF BOLT HOLES
 O-DIA OF BOLT HOLES
 C-DIA OF BOLT CIRCLF

L-TORQ XOMOX FIG. L067 & L0367

Double Acting - Class 150 & 300

Double Acting with 80 PSIG air supply

L-TORQ XOMOX FIG. L067 & L0367, SIZE 1/2"-6", Class 150 and 300

SIZE		CLASS	DIMENSIONS (inch)												WEIGHT (lbs)
			A	B	C	D	E	F	G	L	N	O	P	T	
1/2"	DN 15	150	2.52	6.53	2.38	3.50	1.00	1.30	7.05	4.25	4	0.63	1.38	0.37	9.5
3/4"	DN 20	150	2.52	6.53	2.75	3.90	1.00	1.30	7.05	4.61	4	0.63	1.69	0.40	10.4
1"	DN 25	150	2.60	7.78	3.12	4.25	1.37	1.63	8.35	5.00	4	0.63	2.00	0.44	17.2
1 1/2"	DN 40	150	3.35	10.27	3.88	5.00	1.61	2.19	10.16	6.50	4	0.63	2.87	0.56	27.1
2"	DN 50	150	3.35	11.34	4.75	5.98	2.17	2.72	11.71	7.01	4	0.75	3.62	0.62	42.3
3"	DN 80	150	3.35	11.34	6.00	7.48	2.17	2.72	12.26	7.99	4	0.75	5.00	0.75	58
4"	DN 100	150	4.13	14.31	7.50	9.02	2.64	3.19	14.90	9.02	8	0.75	6.19	0.94	99
6"	DN 150	150	4.33	17.78	9.50	10.98	3.07	3.78	17.59	10.51	8	0.88	8.50	1.00	167.1
1/2"	DN 15	300	2.52	6.53	2.62	3.74	1.00	1.30	7.05	5.51	4	0.63	1.38	0.56	11
3/4"	DN 20	300	2.52	6.53	3.25	4.61	1.00	1.30	7.05	5.98	4	0.75	1.69	0.62	13
1"	DN 25	300	2.60	7.78	3.50	4.88	1.37	1.63	8.35	6.26	4	0.75	2.00	0.68	20.7
1 1/2"	DN 40	300	3.35	10.27	4.50	6.10	1.61	2.19	10.16	7.48	4	0.88	2.87	0.81	34.2
2"	DN 50	300	3.35	11.34	5.00	6.50	2.17	2.72	11.71	8.50	4	0.75	3.62	0.87	49.2
3"	DN 80	300	3.35	11.34	6.62	8.27	2.17	2.72	12.26	11.10	4	0.88	5.00	1.12	73.4
4"	DN 100	300	4.13	14.31	7.88	10.00	2.64	3.19	14.90	12.01	8	0.88	6.19	1.25	123.9
6"	DN 150	300	4.33	17.78	10.62	12.52	3.07	3.78	17.59	15.87	8	0.88	8.50	1.44	223.1

L-TORQ XOMOX FIG. L067 & L0367, SIZE 1/2"-6", Class 150 and 300

SIZE		CLASS	DIMENSIONS (mm)												WEIGHT (kg)
			A	B	C	D	E	F	G	L	N	O	P	T	
1/2"	DN 15	150	64	166	60	89	25	33	179	108	102	16	35	9	4
3/4"	DN 20	150	64	166	70	99	25	33	179	117	102	16	43	10	5
1"	DN 25	150	66	198	79	108	35	41	212	127	102	16	51	11	8
1 1/2"	DN 40	150	85	261	99	127	41	56	258	165	102	16	73	14	12
2"	DN 50	150	85	288	121	152	55	69	297	178	102	19	92	16	19
3"	DN 80	150	85	288	152	190	55	69	311	203	102	19	127	19	26
4"	DN 100	150	105	363	191	229	67	81	378	229	203	19	157	24	45
6"	DN 150	150	110	452	241	279	78	96	447	267	203	22	216	25	76
1/2"	DN 15	300	64	166	67	95	25	33	179	140	102	16	35	14	5
3/4"	DN 20	300	64	166	83	117	25	33	179	152	102	19	43	16	6
1"	DN 25	300	66	198	89	124	35	41	212	159	102	19	51	17	9
1 1/2"	DN 40	300	85	261	114	155	41	56	258	190	102	22	73	21	16
2"	DN 50	300	85	288	127	165	55	69	297	216	102	19	92	22	22
3"	DN 80	300	85	288	168	210	55	69	311	282	102	22	127	28	33
4"	DN 100	300	105	363	200	254	67	81	378	305	203	22	157	32	56
6"	DN 150	300	110	452	270	318	78	96	447	403	203	22	216	37	101

Pressure and Temperature Ratings

Temp [°F]:	-76	-4	32	122	167	212	302	392	437	482	572
CF8M CL150	276	276	276	267	251	235	215	199	187	175	148
CF8M CL300	719	719	719	697	655	612	558	518	501	484	458
WCB CL150	-	284	284	278	268	257	229	200	188	175	148
WCB CL300	-	741	741	726	701	676	654	635	621	608	577
PFA	1450	1450	1450	1450	1305	725	435	218	145	116	-

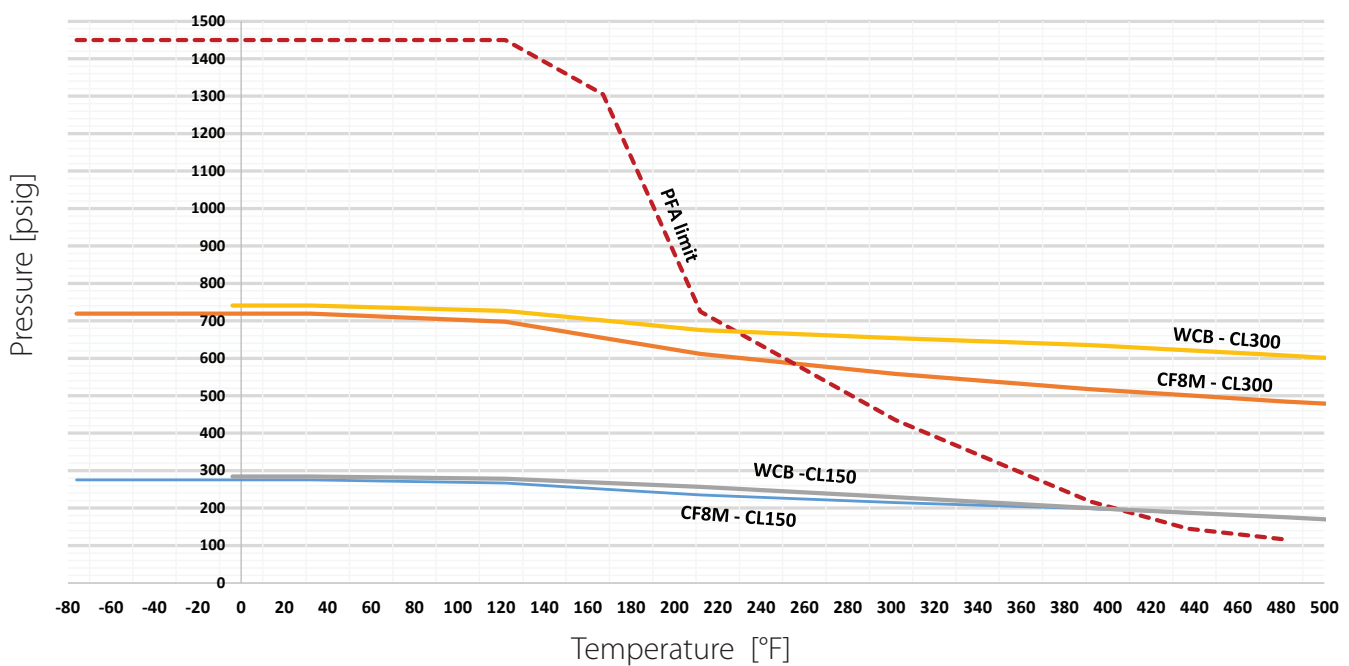

OPERATING TORQUES. (INCH-POUNDS)

Size	Break Torque	Seat Torque	Run Torque
1/2"	70	80	71
3/4"	70	80	71
1"	190	151	133
1½"	400	319	284
2"	545	434	381
3"	660	532	461
4"	1,350	1,080	948
6"	2,700	2,169	1,877

* Figures are for 2-Way valves with PFA Cartridge for clean media. For Chlorine, Oxygen etc. Dry Built configurations multiply the above values with 1.5

Pressure and Temperature Ratings

Temp [°C]:	-60	-20	0	50	75	100	150	200	225	250	300
CF8M CL150	19	19	19	18.4	17.3	16.2	14.80	13.7	12.9	12.1	10.2
CF8M CL300	49.6	49.6	49.6	48.1	45.2	42.2	38.50	35.7	34.6	33.4	31.6
WCB CL150	-	19.6	19.6	19.2	18.5	17.7	15.80	13.8	13.0	12.1	10.2
WCB CL300	-	51.1	51.1	50.1	48.4	46.6	45.10	43.8	42.9	41.9	39.8
PFA	100	100	100	100	90	50	30	15	10	8	-

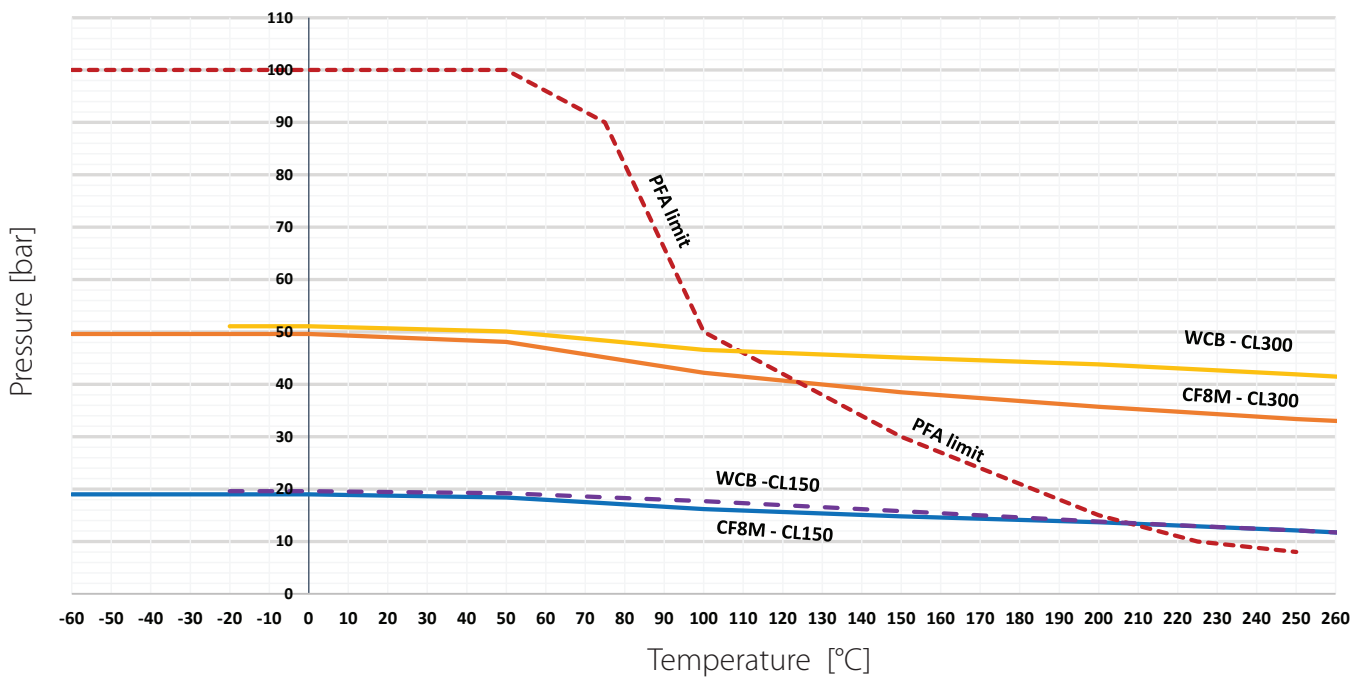

OPERATING TORQUES. (NM)

Size	Break Torque	Seat Torque	Run Torque
1/2"	8	9	8
3/4"	8	9	8
1"	21	17	15
1½"	45	36	32
2"	62	49	43
3"	75	60	52
4"	153	122	107
6"	305	245	212

* Figures are for 2-Way valves with PFA Cartridge for clean media. For Chlorine, Oxygen etc. Dry Built configurations multiply the above values with 1.5

MAST and Kv/Cv Values

L-TORQ MAST (ANSI/DIN)

Size		1.4408/CF8M	1.4470 (Duplex) / CD4MCuN
1/2"	DN 15	62	96
3/4"	DN 20	62	96
1"	DN 25	107	164
1 1/2"	DN 40	222	343
2"	DN 50	222	343
2 1/2"	DN 65	222	343
3"	DN 80	222	343
4"	DN 100	576	892
5"	DN 125	852	1318
6"	DN 150	852	1318

Kv / Cv Values L067 class 150 & L0367 class 300

ANSI		
	KV	CV
1/2"	14	16
3/4"	16	19
1"	45	52
1 1/2"	101	117
2"	186	215
3"	306	354
4"	538	622
6"	1066	1232

Kv / Cv Values L127 PN10-40

DIN		
	KV	CV
DN 15	14	16
DN 20	16	19
DN 25	47	54
DN 32	47	54
DN 40	103	119
DN 50	190	220
DN 65	190	220
DN 80	350	405
DN100	615	711
DN125	615	711
DN150 SHORT	1066	1232
DN150 LONG	1109	1282

Product Coding

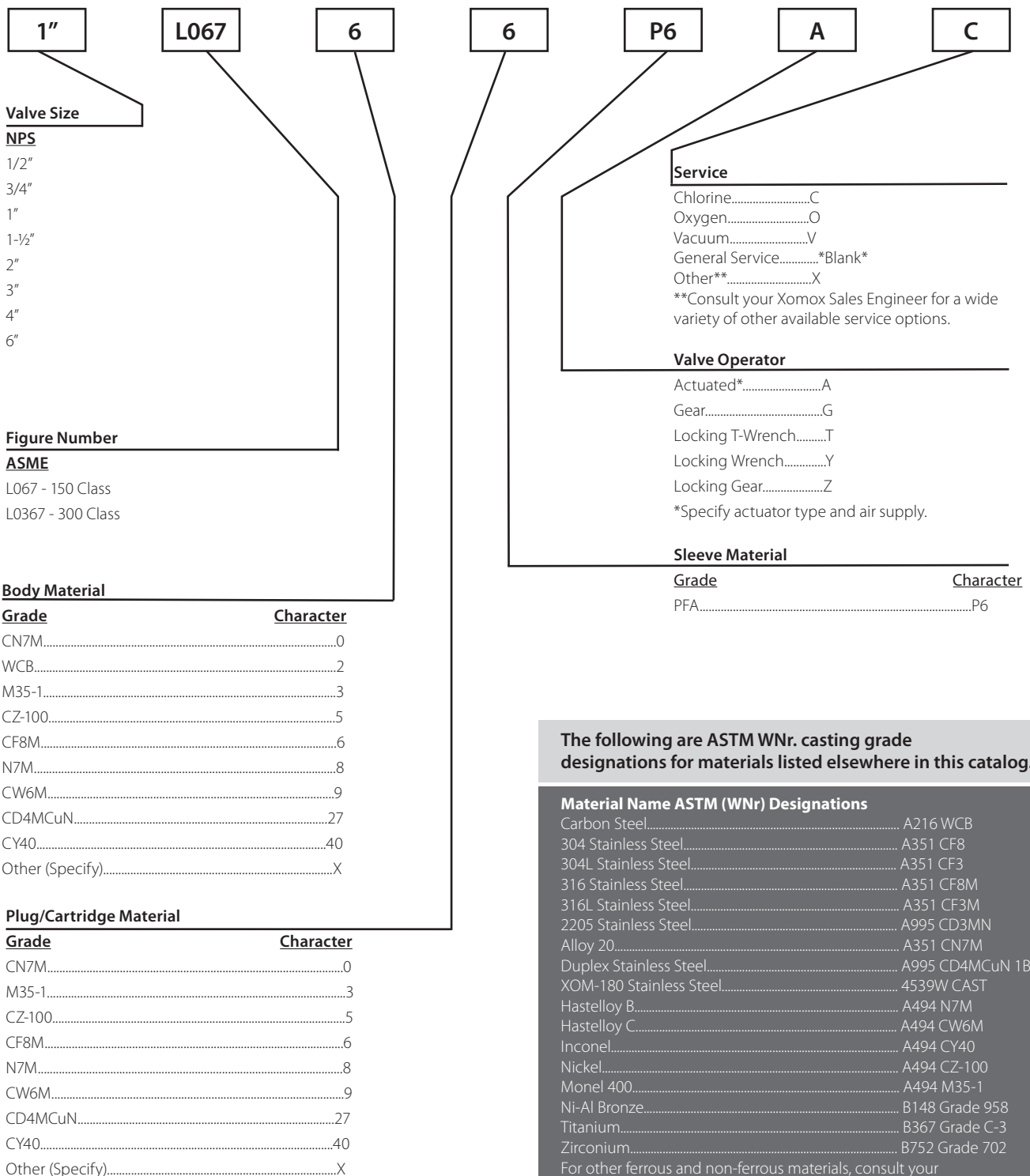

The following are ASTM WNr. casting grade designations for materials listed elsewhere in this catalog.

Material Name ASTM (WNr) Designations

Carbon Steel.....	A216 WCB
304 Stainless Steel.....	A351 CF8
304L Stainless Steel.....	A351 CF3
316 Stainless Steel.....	A351 CF8M
316L Stainless Steel.....	A351 CF3M
2205 Stainless Steel.....	A995 CD3MN
Alloy 20.....	A351 CN7M
Duplex Stainless Steel.....	A995 CD4MCuN 1B
XOM-180 Stainless Steel.....	4539W CAST
Hastelloy B.....	A494 N7M
Hastelloy C.....	A494 CW6M
Inconel.....	A494 CY40
Nickel.....	A494 CZ-100
Monel 400.....	A494 M35-1
Ni-Al Bronze.....	B148 Grade 958
Titanium.....	B367 Grade C-3
Zirconium.....	B752 Grade 702

For other ferrous and non-ferrous materials, consult your Crane ChemPharma & Energy/XOMOX Sales Engineer.



CRANE CHEMPHARMA & ENERGY

Xomox International GmbH & Co.OHG
Von-Behring-Straße 15
88131 Lindau (Bodensee)
Germany
Tel.: +49 8382 702-0

Xomox Corp.
4444 Cooper Road,
Cincinnati, OH 45242
USA
Tel.: (513) 745-6000

Crane Company, and its subsidiaries cannot accept responsibility for possible errors in catalogues, brochures, other printed materials, and website information. Crane Company reserves the right to alter its products without notice, including products already on order provided that such alteration can be made without changes being necessary in specifications already agreed. All trademarks in this material are the property of the Crane Company or its subsidiaries. The Crane and Crane brands logotype (ALOYCO®, BAUM®, CENTER LINE®, CRANE®, CRYOWORKS®, DEPA® & ELRO®, DOPAK®, DUO-CHEK®, FLOWSEAL®, GYROLOK®, GO REGULATOR®, HOKE®, JENKINS®, KROMBACH®, NOZ-CHEK®, PACIFIC®, RESISTOFLEX®, XOMOX®, SAUNDERS®, STOCKHAM®, TECHNIFAB®, TEXAS SAMPLING®, WESTLOCK CONTROLS®, WTA®, and XOMOX®) are registered trademarks of Crane Company. All rights reserved.
