

XOMOX[®]

XOMOX[®]
SLEEVED PLUG
VALVES
SERIES FEO



OPERATING AND MAINTENANCE INSTRUCTIONS

CRANE[®]



www.cranecpe.com

Table of Contents

General Information	3
Troubleshooting	7
Kit Options	8
Repair Instructions	9

General Information

Introduction

These instructions are to support the user with installation, operation and maintenance of valves.

⚠ Caution

If the subsequent caution and warning comments are not adhered to, danger can result thereof and the guarantee of the manufacturer becomes null and void. The manufacturer is at your disposal for further requests, for addresses see last page.

1. Intended Use

TUFLIN plug valves are only intended to lock or pass through media within the permitted pressure and temperature limits after setup of the manual operating possibilities or after installation of the actuator to the control. TUFLIN plug valves are only intended, after the installation in a pipeline system, after the setup of the manual operating possibilities or after connection of the actuator to the control, to lock or pass through or divert flows of media or divide the flow or to mix several flows depending upon the design of the plug within the permissible pressure and temperature limits. The permitted pressure and temperature range is described in the technical data sheet. Only plug valves, whose type no. begins with a 5 are suitable for regulating, these plug valves are not recommended for media with wetted solid materials. All other plug valves are permitted only for the OPEN-CLOSE-operation.

⚠ Caution

If a valve with differential pressures larger than approx. 0.15 bar (liquid media) is used for the controlling in the continuous operation, the system limits are to be observed in accordance with XOMOX-data sheet.

The multi-way plug valve in its standard design is designed accordingly that the medium has approximately the same pressure in each case in the piping branches that are connected with each other.

⚠ Caution

If for process engineering reasons the individual flow cross section in the plug have to be of various sizes - e.g. because of different initial pressures in the inflow lines which are to be mixed - consultation with the manufacturer XOMOX is necessary.

Safety

General Safety Notes

The same safety regulations apply for valves as for the piping system in which they are installed and as for the control system to which the actuator is connected. The instructions available provide only such safety notes which are to be observed additionally for valves. For actuator units additionally safety notes are contained in the respective operating instructions.

Safety Notes for Operator

It is not within the responsibility of the manufacturer, and thus when using the valve, to ensure that

- the valve is used as intended in such a way as described in the Section 1.

⚠ Danger

Safeguard against improper use of the valve:
It must be particularly ensured that the selected materials of the wetted parts of the valve are suitable for the used media. **Ignorance of these precautionary measures can mean danger for life and limb and cause damage in the piping system.**

- an actuator or a manual operating possibility which has been installed subsequently onto the valve, and adapted to the valve is adjusted correctly in all positions of the valve.
- the piping system (and the control system) was assembled professionally and are checked regularly. The wall thickness of the body of the valve is dimensioned in such a way that in such professionally assembled lines an additional load in the usual size ($= \pi/4 \cdot DN^2 \cdot PS$) is taken into account ($PS = \text{maximal permissible design pressure at ambient temperature}$).
- the valve is connected professionally to these systems.
- in this piping system the usual flow speeds (e.g. 4 m/s for liquids) are not exceeded in the continuous operation, and abnormal operation conditions such as oscillations, water shocks, cavitation and larger portions of solid materials in the medium – in particular abrasive – are to be agreed upon with the manufacturer XOMOX.
- valves which are operated at operating temperatures $>50^\circ\text{C}$ or $<-20^\circ\text{C}$ are protected together with the piping connections against being touched.

General Information

- only for pressure-conducting pipelines, qualified employee operates, services and repairs the valve
- No marking according to directive 94/9/EG (ATEX)

XOMOX valves were examined in the scope of the directive 94/9/EG regarding of an assessment of danger of ignition in accordance with DIN EN 13463-1. The valves exhibit no own potential ignition sources and do not fall thus under the requirements of the directive. A CE marking following this directive is not permissible. The valves can be used in a potentially explosive area. The valve has to be included into the electric potential analysis of the plant with regard to all metal parts in potentially explosive atmospheres independently of the guideline.

Special Hazards

⚠ Danger to Life

Before loosening the screw connection at the cover or before dismantling the valve of the pipeline, **the pressure in the pipeline must be completely diminished**, so that the media does not escape unchecked from the line.

⚠ Danger

For valves, which are used as end valve: During normal use, in particular with gas-like, hot and/or dangerous media a blind flange must be mounted at the free connecting pieces or the valve must be securely locked in „CLOSE“-position.

⚠ Danger

If a valve has to be opened as end valve in a pressure containing line, this may take place with all caution only in such a way that the spurting media does not cause any damage.

⚠ Danger

If a valve must be disassembled from a pipeline, media can escape from the line or from the valve. With unhealthy or dangerous media the pipeline must be completely emptied before the valve is disassembled. Caution with **residues which reflow from the line or which have remained in dead spaces of the valve (under pressure)**.

Valve Marking

The valve is marked according to EN 19 or on customer request. Markings may not be damaged, so that the valve can be identified.

Transport and Storage

Valves must be treated, transported and stored carefully:

- The valve is to be stored in its protective package and/or with the protective caps at the connection ends. Valves which are heavier than approx. 10 kg, should be stored and transported on a pallet (or similar supported) (also to the installation place).
- With storage before installation, valve, gear and actuator are to be protected from damaging influences such as dirt or humidity and are to be stored at ambient temperature.
- Particularly the actuator, the gear and the ends of the valve to the piping connection may neither be damaged through mechanical nor other influences.
- Valves must be stored in such a way as they were supplied. The operating device may not be activated.

Installation into Pipeline

General Instructions

For the installation of valves into a piping, the same instructions apply as for the connection of pipes and similar piping elements. For valves, the subsequent instructions apply additionally. For the transport to the installation place also the Section 3 (above) is to be considered.

⚠ Danger to Life

If an actuator unit is retrofitted, torque, rotation direction, operating angle and the adjustment of the final impacts „OPEN“ and „CLOSE“ must be adapted to the valve. **Ignoring these regulations could mean danger for life and limb and cause damage to the piping system.**

⚠ Danger

The actuator is adjusted for the operating data indicated in the order:
The adjustment of the final impacts „OPEN“ and „CLOSE“ apted to the switching positions of the valve may not be changed without agreement of the manufacturer.

General Information

⚠ Danger

Since a multi-way plug valve has several flow directions, it is to be observed with the installation that the possible switching positions correspond with the required flow directions. The technical data sheet shows an appropriate outline. Appropriate markings are attached to the plug shaft

⚠ Danger

Only for valves with electric drive:
It is to be ensured that the actuator is switched off in all final and intermediate positions by the signal of the limit switch. The signal of the torque switch can be used for an alarm. For further information, see the operating instructions of the electric drive.

Installation Steps

- Transport valve in the protective package to the installation place and remove it only there.
- Examine valve, gear and actuator for transport damage. Damaged units may not be installed.
- Ensure that only valves are installed whose pressure class, type of connection and connection dimensions correspond to the application conditions. The connection data for the actuator must correspond with the data of the control. See labelling at the actuator.

⚠ Danger to Life

No valve may be installed whose approved pressure/temperature range is not sufficient for the operating condition:

This approved range is described in the XOMOX catalogue B – see Section 8. **Ignoring these regulations could mean danger for life and limb and cause damage to the piping system.** In the case of doubt the manufacturer XOMOX is to be consulted.

- Check the function of the multi way valves before the installation: The type of the plug must be selected correctly for the in-tended flow directions in the pipe system.
- The connection ends of the piping must align with the connection ends of the valve and have plane parallel ends.

⚠ Danger

Multi-way plug valves are – according to function – supplied with the suitable plug: The type of the plug form is indicated in the shaft in accordance with the technical data sheet tdb_137_de-Multi-way-plug-valves.

- Before the installation, the valve and the subsequent piping must be cleaned carefully of dirt, in particular from hard foreign sub-stances.
- The valve can be installed in arbitrary installation position. The actuator is, however, to be arranged – if possible – not directly underneath the valve: Leakage at the switching shaft can damage the actuator.
- When inserting the valve (and the necessary sealings) in an already mounted pipeline the distance between the piping ends must be dimensioned in such a way that all connection and/or sealing surfaces (and sealings) remain undamaged.
- For the connection of the actuator unit to the control, the appropriate instructions apply.
- For the termination of the installation a functional test with the signals of the control is to be executed with the actuated valves: The valve must close and open correctly according to the control commands. Detectable functioning
- Faults are absolutely to be remedied before the commissioning. See also Section 7.

⚠ Danger to Life

Faulty executed control commands could **mean danger for life and limb and cause damage to the piping system.**

Pressure Test of the Pipe Section

For the pressure test of the valves the same instructions apply as for the piping. Additionally applies:

- Rinse new installed line systems carefully in order to wash out foreign substances.

The pressure test of an opened valve may not exceed the value $PT=1,5 \times PN/PS$. A closed valve may be tested under pressure only with $PT=1,1 \times PN/PS$ according to marking.

General Information

Normal Operation and Maintenance

Which were supplied ex-factory with actuator or gear are exactly adjusted and may not be adjusted as long as a valve operates perfectly. For the manual operation or the hand emergency operation at the actuator (if available) normal hand force is sufficient; the usage of extension for the increase of the actuation moment is not permissible.

Caution

The position of the two-flax at the shaft indicates the position of the valve:

Two-flax 90° transverse to the flow: valve closed,
two-flax parallel to the flow: valve opened.

Danger to Life

Only for valves with hand lever: The opening and closing may not take place jerkily, but must be effected quickly in such a way that pressure surges and/or temperature shocks in the line system are avoided. Ignoring this warning information can cause extreme danger for persons or for the piping system.

Regular maintenance work are not necessary at valves, but no medium may escape when checking the line section. With leakage and repairs see Section 2 and Section 7.

Caution

The sealing (pressed on sleeve in the body) is pre-tensioned for seat sealing: This pretension, which is adjusted ex-factory by means of 3 adjusting screws in the cover, is not to be modified as long as the plug valve is leak-proof.

Troubleshooting

Type of the Fault	Measurement	Notes
Leakage at the screw	Retighten connection.	
Flange connection to pipeline	Retighten cover screw connection. If the leakage cannot be remedied by this: Repair is necessary: Spare parts and necessary instructions are to be requested from	
Leakage in closed position Leakage at the plug shaft seal	<p>Readjust pretension of the sealing:</p> <p>With 3 Allen screws in the cover the pretension of the seat sealing can be increased: Screw in all 3 screws alternatingly through a ¼ rotation each in the clockwise direction until the leakage is remedied.</p> <p>With type 127: For seat leakage, note the 6 hex head screws in the cover. Of the 6, the smaller 3 grub screws adjust the seat seal. Screw in all 3 screws alternatingly through a ¼ rotation each in the clockwise direction until the leakage is remedied.</p> <p>For stem leakage, the larger 3 socket head cap screws adjust the stem packing . Screw in the 3 screws alternatingly a ¼ rotation each in the clockwise direction until the leakage is remedied.</p> <p>If the leakage can not be remedied by this or the plug valve moves then too heavily: Repair is necessary: Spare parts and necessary instructions are to be requested from XOMOX. Observe Section 2.3 If these 3 Allen screws in the cover are loosened or the cover have to be unscrewed: Observe Section 2.3</p> <div style="border: 2px dashed black; padding: 5px; text-align: center;"> <p>⚠ Danger to Life</p> <p>To safeguard the operating staff against danger, ensure that the line is completely depressurized beforehand</p> </div>	<p><u>Note 1:</u> Only original XOMOX®-spare parts may be installed.</p> <p><u>Note 2:</u> If, after dismantling, it turns out that the media media-exposed inner parts are not sufficiently resistant to the medium, parts made of a suitable material must be selected.</p>
Malfunction	Check actuator unit and control commands. If actuator and control are okay: Dismantle valve (observe thereby the notes of Section 2.3) and inspect. If the valve is damaged: Repair is necessary: Spare parts and necessary instructions are to be requested from	

Kit Options

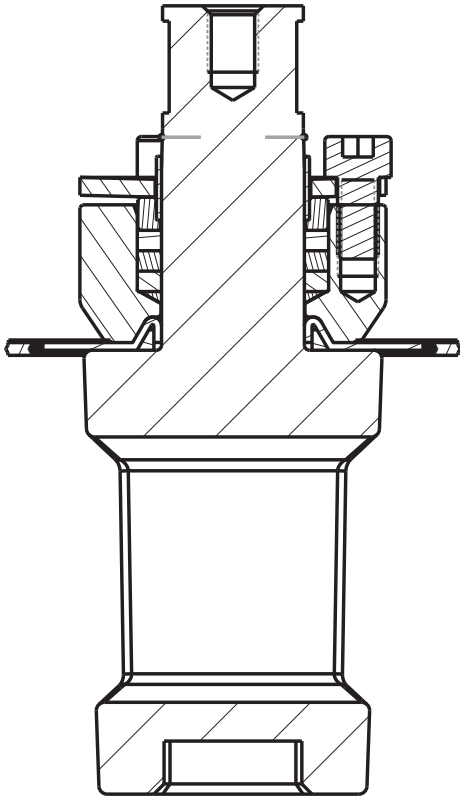

Kit A: Complete Plug Kit

Includes:

1. Plug
2. Cover Gasket
3. Complete top seal, pre-assembled
 - A. Wedge Ring
 - B. Formed Diaphragm
 - C. Stuffing Box
 - D. Packing
 - E. Follower
 - F. Spring Washer
 - G. PEEK Ring
 - H. Stem Bearing
 - I. Anti-static Ring
 - J. Packing Adjustment Bolts

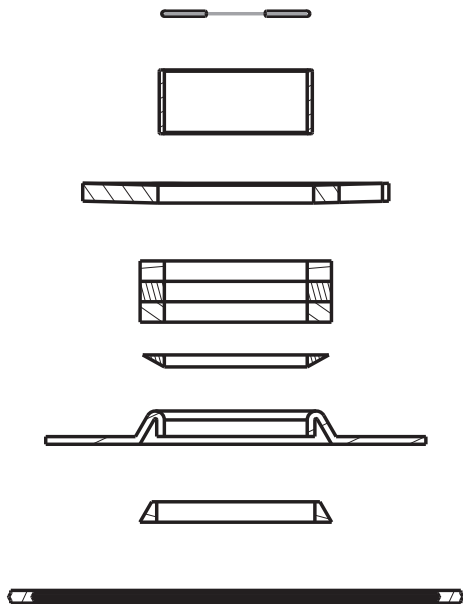

Kit B, Spare Part Repair Kit

Includes:

1. Wedge Ring
2. Formed Diaphragm
3. Packing Rings
4. PEEK Ring
5. Stem Bearing
6. Spring Washer
7. Cover Gasket
8. Protection/Installation tool

Repair Instructions

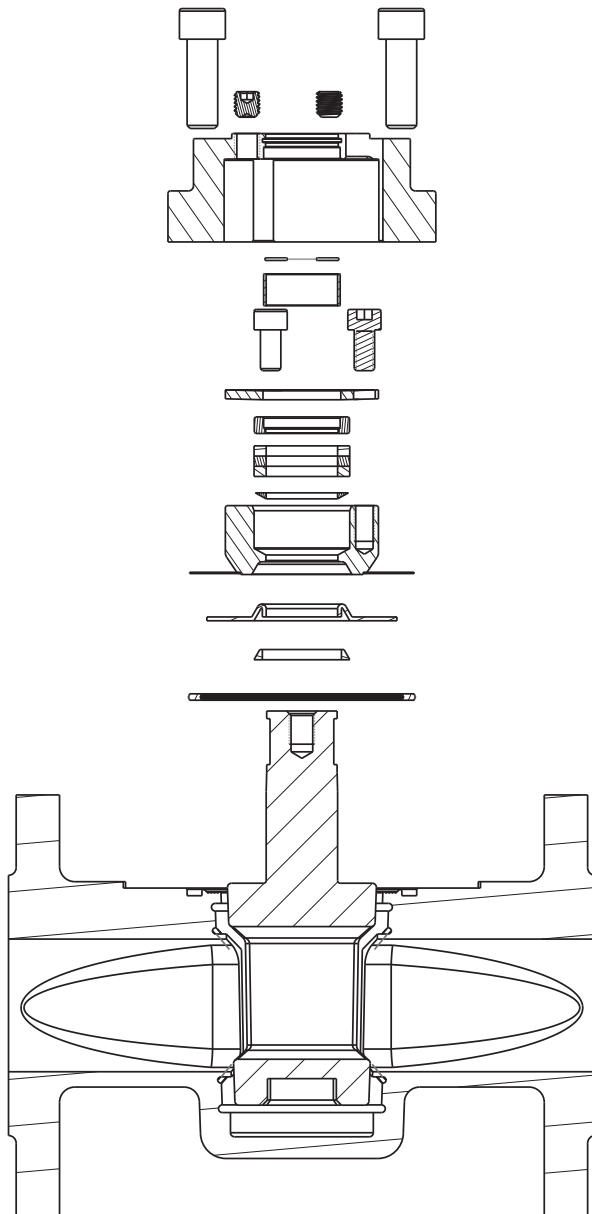

Fig. 1

1. Remove Operating Device and Cover (fig. 1)

DN15 - 400 resp. NPS 1 - 16

Remove operating device, loosen plug adjusting screws (B) loosen cover screws (A) by 3 turns (due to safety reasons do not remove yet). Turn plug by operating device available and release cover by loosening cover screws and alternately turning plug. Remove cover screws. Remove cover and re-tighten 3 adjusting bolts until they are on the body level. Clean cover.

2. Remove Seal Kit and Plug (fig. 1)

DN15 - 400 resp. NPS 1 - 16

Remove seal kit (D) - Stuffing Box (Packing Rings, Follower, Spring Washer, Adjustment Screws), Formed Diaphragm, Wedge Ring and Cover Seal. Turn plug and while doing so, lift plug out of body with the wrench and check whether the plug is still usable. The plug surface has to be treated carefully and shall not be damaged and has to be free of retentions. Plug repair shall not be done. In this case the maintenance has to be done by XOMOX.

Repair Instructions

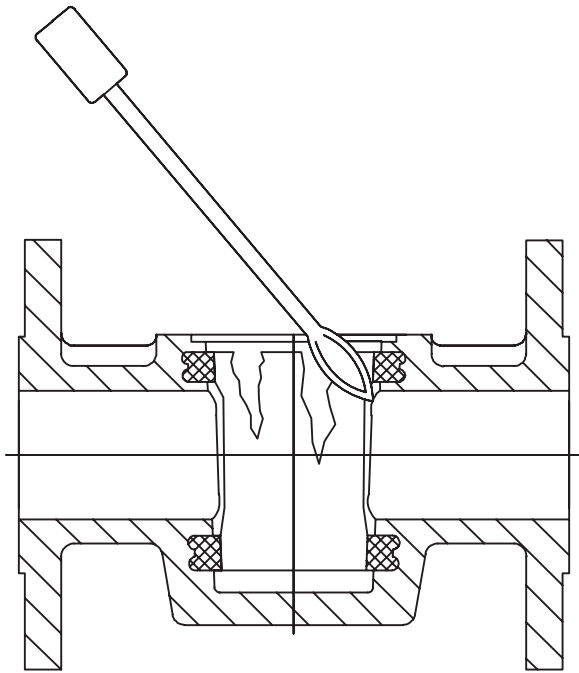

Fig. 2

3. Cut Out Old Sleeve (fig. 2)

DN15 - 400 resp. NPS 1 - 16

Cut out old sleeve and clean inside of body.

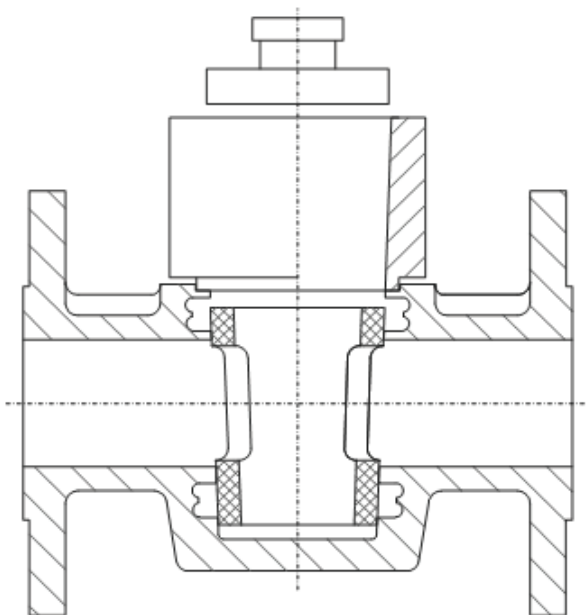

Fig. 3

4. Re-Install Sleeve (fig. 3 + 4)

DN15 - 100 resp. NPS 1 - 4

Install sleeve slightly offset so that sleeve can fit to the vertical ribs surrounding each port opening (fig. 4). Press sleeve under the metal ribs on upper part of the body.

DN 125 - 400 resp. NPS 5 - 16

Heat covered sleeve to 90°C for 30 min. Mount charging ring on cover center bore. Install uncovered sleeve slightly offset into charging ring so that sleeve can fit to the vertical ribs. Press sleeve to bottom by means of contact pieces under the ribs on upper port of the body (fig. 3 + 4).

Repair Instructions

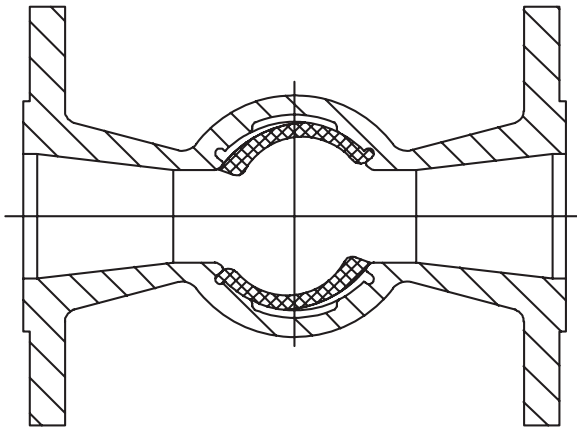

Fig. 4

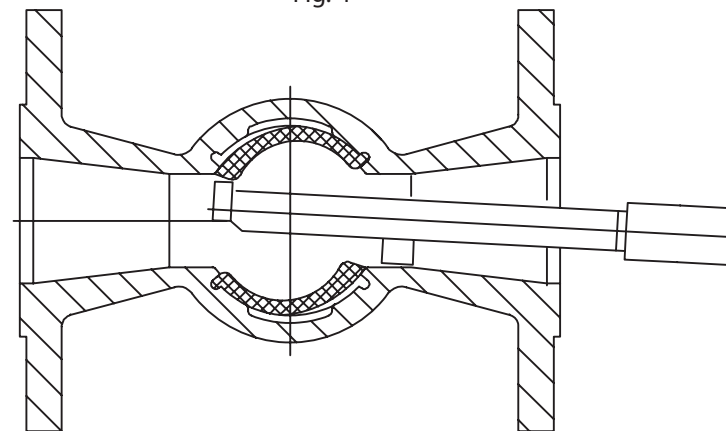

Fig. 5

5. Position Sleeve (fig. 5)

DN15 - 400 or NPS 1 - 16

Using a pry tool, push the sleeve behind the port lips.

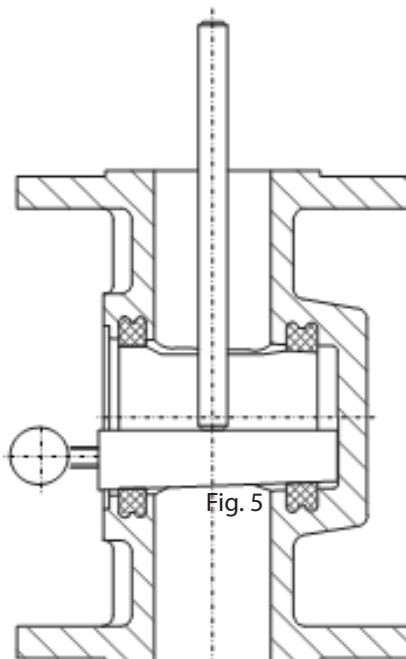

Fig. 5

Fig. 6

6. Press Sleeve (fig. 6)

DN15 - 400 or NPS 1 - 16

Press sleeve on both port openings against wall of body by means of a semicircle-plunger. Remove excess sleeve material with the cutting knife. Clean sleeve and body interior.

Repair Instructions

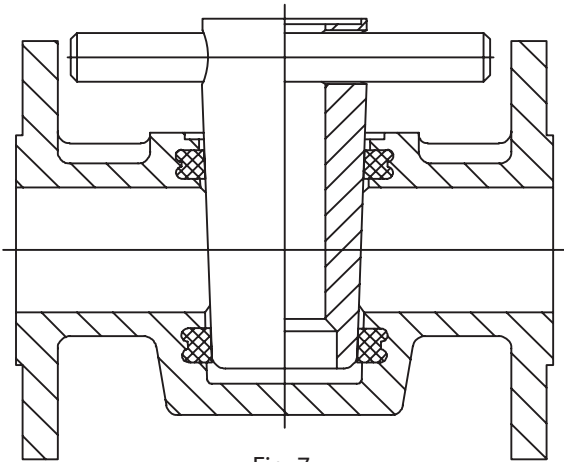

Fig. 7

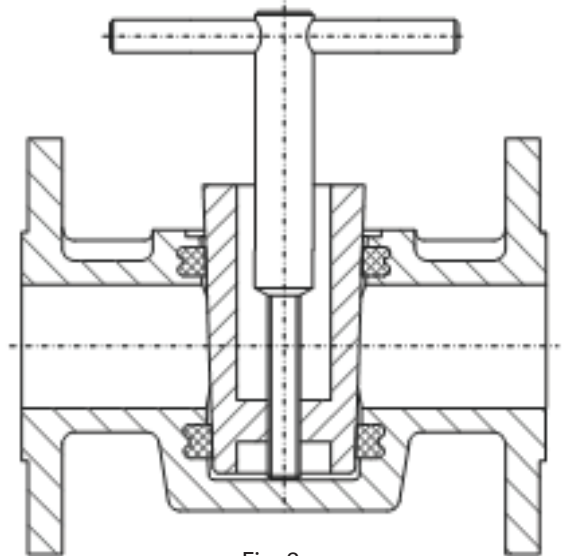

Fig. 8

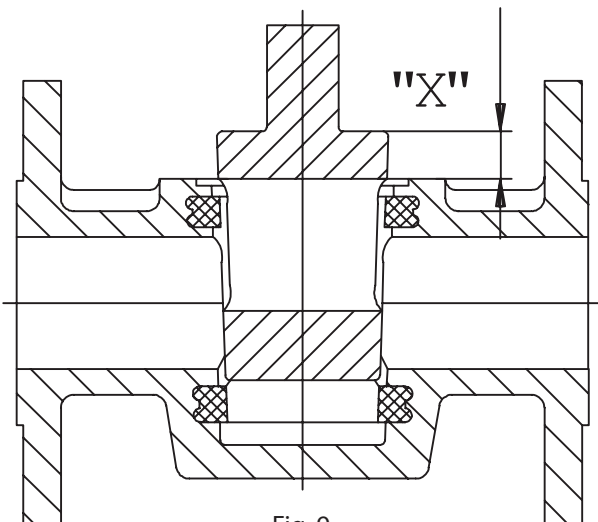

Fig. 9

7. Stamp Sleeve (fig.7, 8 + 9)

DN15 - 100 or NPS 1 - 4

Stamp sleeve with embossing-plunger slowly until plug is touching bottom of body. Use resin-free grease (vaseline) if allowed. Embossing-plunger can be removed by sticking shaft through the two boreholes of the embossing-plunger, turning it and lifting it out at the same time (fig. 7). To assure correct sizing operating, insert plug and check alignment of top of plug port opening with body top (fig. 9) resp. consider projecting dimensions of plug see tab. 1. Re-stamping may be necessary. Clean sleeve and body interior.

DN 125 - 400 or NPS 5 - 16

Stamp sleeve with embossing-plunger slowly until plug is touching bottom of body. Use resin-free grease - if allowed. Plug can be removed by using the jack screw (fig. 8). To assure correct sizing operation, insert plug and consider projecting dimensions of plug (see tab. 1 and fig. 9). Re-stamping may be necessary. Clean sleeve and body interior.

DN	25-32	40	50-80	100	125-150	200-300
NPS	1-1¼	1½	2-3	4	5-6	8-12
"X" (mm)	8	12	15	18	15	10

Tab. 1

Repair Instructions

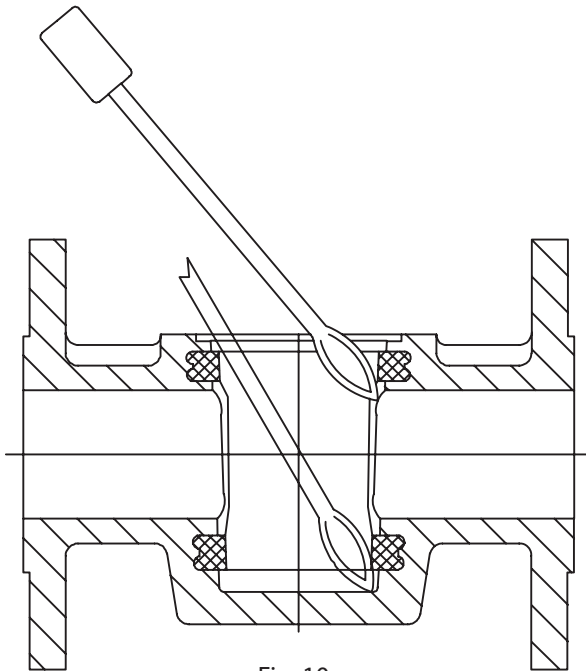

Fig. 10

8. Trim Sleeve (fig. 10)

DN15 - 400 or NPS 1 - 16

Excess sleeve material should be trimmed with cutting knife around the ports and at the top of the sleeve. Clean sleeve and body interior.

Type 147 / 047 / 177 / 077

Cut out the additional port with cutting knife (use the same sleeve with two ports as type 127/067).

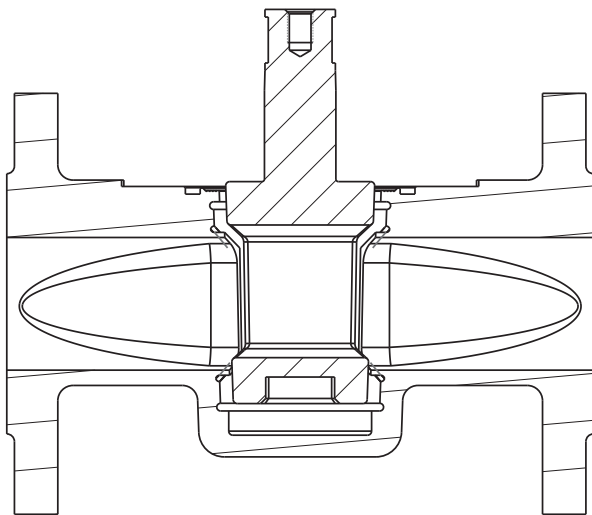

Fig. 11

9. Install Plug (fig. 11)

DN15 - 400 bzw. NPS 1 - 16

Plug (15) clean thoroughly, grease it unless the service does not allow it (oxygen service,...), insert the plug into the body.

*If utilizing complete plug kit (Kit A), skip step 10 and proceed to step 11 (cover installation).

Repair Instructions

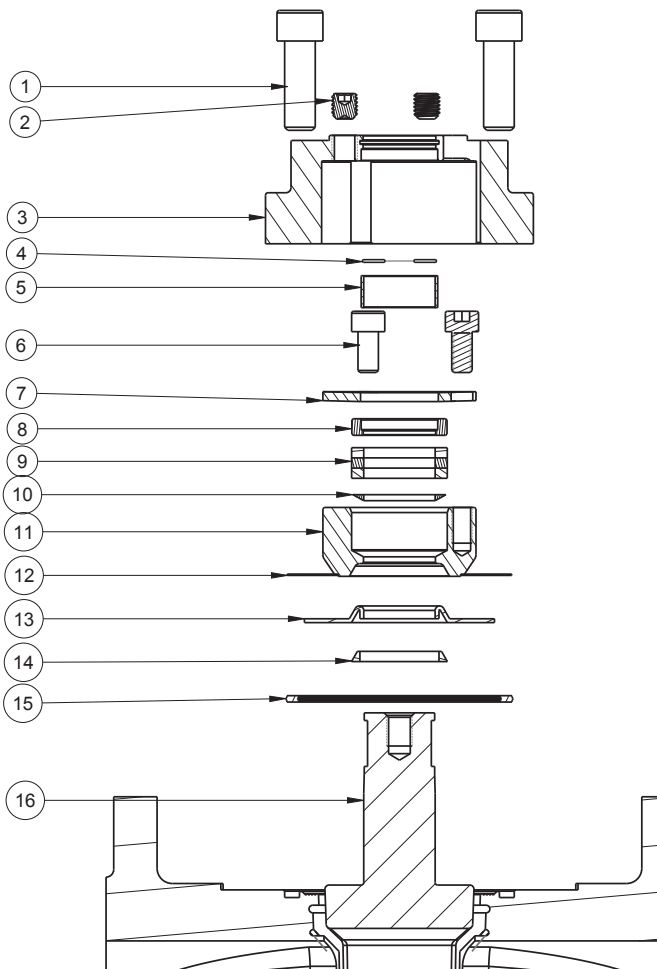

Fig. 12

10. Install Seal Kit (Kit B) (fig. 12)

- a. Put cover seal (15) in the body groove.
- b. Put wedge-ring (14) on plug shoulder.
- c. Put the assembly cone (not shown) over plug stem.
- d. Pull over carefully formed diaphragm (13) on plug and press it down to plug shoulder. Remove assembly cone.
- e. Put stuffing box (11) with welded steel diaphragm (12) on formed PTFE diaphragm.
- f. Insert PEEK ring (10) into stuffing box, with tapered edge facing down as shown in Fig. 12
- g. Insert packing (9) [PTFE as standard and graphite as fire safe] into the stuffing box. Take care not to damage the packing when placing over the stem.
- h. Place the follower (8) onto the packing.
- i. Align the spring washer (7) onto the follower, aligning the through holes with the tapped holes in the stuffing box.
- j. Put the cap screws (6) through the holes in the spring washer and tighten them into the stuffing box to the torques listed in Table 2.
- k. Put the stem bearing (5) and ground washer (4) back onto the stem.

11. Install Cover

- a. Insert the adjusting screws into the cover holes (2).
- b. Put cover (3) on the top seal group ensuring alignment of plug adjustment bolts with the holes in the cover.
- c. Tighten the cover bolts (1) to proper torque spec (Table 3)

Repair Instructions

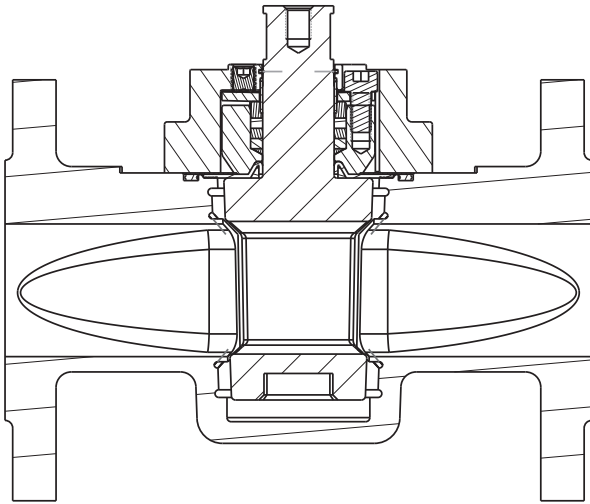

Fig. 13

Valve Size	Packing Screw Tightening Torque [Nm]	
	PTFE	Graphite
1/2" (DN15)	3	3,3
1" (DN25)	3,2	4
1-1/2" (DN40)	7	9
2" (DN50)	11	13,5
3" (DN80)	11	13,5
4" (DN100)	20	25
6" (DN150)	40	50

Tab. 2

Bolt Size	Packing Screw Tightening Torque [Nm]
M8	16
M10	35
M12	35
M16	140
M20	280

Tab. 3

12. Re-Install Operating Device.

CRANE[®]

CRANE CHEMPHARMA & ENERGY

Xomox International GmbH & Co.OHG
Von-Behring-Straße 15
88131 Lindau (Bodensee)
Germany
Tel.: +49 8382 702-0

Xomox Corp.
4444 Cooper Road,
Cincinnati, OH 45242
USA
Tel.: (513) 745-6000

Crane Company, and its subsidiaries cannot accept responsibility for possible errors in catalogues, brochures, other printed materials, and website information. Crane Company reserves the right to alter its products without notice, including products already on order provided that such alteration can be made without changes being necessary in specifications already agreed. All trademarks in this material are the property of the Crane Company or its subsidiaries. The Crane and Crane brands logotype (ALOYCO[®], BAUM[®], CENTER LINE[®], CRANE[®], CRYOWORKS[®], DEPA[®]& ELRO[®], DOPAK[®], DUO-CHEK[®], FLOWSEAL[®], GYROLOK[®], GO REGULATOR[®], HOKE[®], JENKINS[®], KROMBACH[®], NOZ-CHEK[®], PACIFIC[®], RESISTOFLEX[®], XOMOX[®], SAUNDERS[®], STOCKHAM[®], TECHNIFAB[®], TEXAS SAMPLING[®], WESTLOCK CONTROLS[®], WTA[®], and XOMOX[®]) are registered trademarks of Crane Company. All rights reserved.