

# XOMOX®



SEAL  
THE FUTURE.

## HIGH PERFORMANCE BUTTERFLY VALVES

SERIE 800ISO / 800-EU

**CRANE**



[www.cranecpe.com](http://www.cranecpe.com)

## XOMOX® HPBV Reliability and Sealing Performance

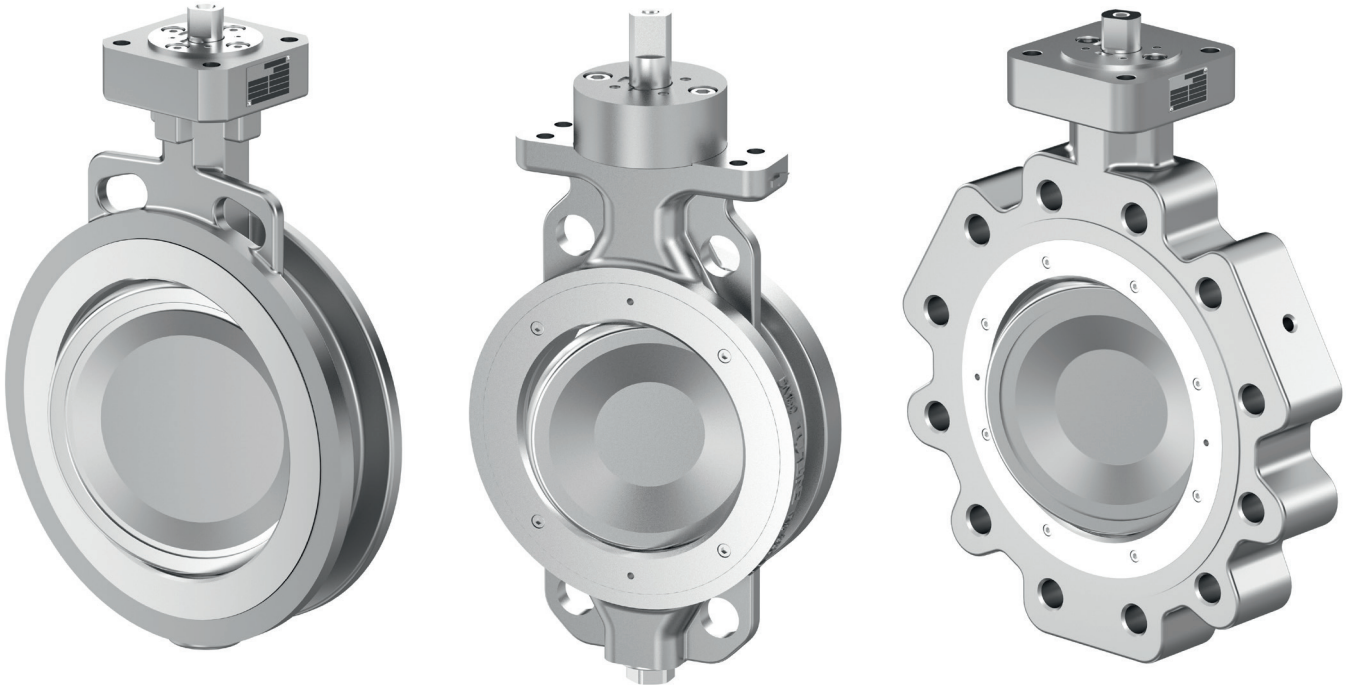

1

### **Certified for Safety**

Tested to TA Luft 2021, ISO 15848: 2017, and API 641 standards to ensure safe operation and prevent costly unplanned shutdowns.

2

### **Uninterrupted Sealing**

The 800ISO (-R) design offers a continuous sealing surface for higher efficiency and bi-directional double dead-end service under full differential pressure.

3

### **Leak-Free Reliability**

ISO mounting flange enables direct actuator installation, while the integral stuffing box eliminates extra leak paths compared to bolt-on designs.

4

### **Durability by Design**

Unique axially pliant seat - no springs, o-rings, or metal hoops - delivers consistent bubble-tight shutoff and long-term reliability per EN 12266-1.

# XOMOX® HPBV Design Features

XOMOX® HPBV come in two designs; 800ISO addressing all your standard needs for your most common sizes, pressure rating and materials; and Series 800 intended to accommodate any special requirement.

## Materials

- Standard: 1.0619, 1.4408; A216 Gr. WCB, A351 Gr. CF8M
- Optional materials available upon request including but not limited to Duplex, Superduplex, LCC/LCB, WC6, CF3M, Monel®, Inconel®, Hastelloy®, Alloy 20; 1.4469, 1.7357, 1.4409, 1.4539

## Size Range

- 800ISO: DN 80 to DN 600 ; 3" to 24"
- Series 800: up to DN 2600 or 102"

## Pressure Ratings

- 800ISO: PN 10, 16, 25, 40; ASME Class 150 & 300#
- Series 800: up to PN 100 or 600#

## Temperature Range

- PTFE: -70°C to +204°C; -94°F to 399°F
- RPTFE: -70°C to +232°C; -94°F to 450°F
- Metal-PEEK: -70°C to +260°C; -94°F to 500°F
- Fire-Safe (Metal/PTFE): -70°C to +300°C; -94°F to 572°F
- Metal/Graphite: -70°C to +550°C; -94°F to 1022°F
- Cryogenic (Metal-PCTFE): -196°C to +50°C; -321°F to 122°F

## Body Configurations

- Lug design
- Wafer design
- Others upon request

## Typical Applications

### Industrial Branches:

- Chemical and petrochemical industry
- Oil and gas
- Air separation
- Chlorine liquefaction
- Power generation
- Energy
- Offshore platforms
- Pulp & paper
- Desalination
- Steam
- Corn processing
- HVAC
- Maritime vessels

### Processes:

- Various chemicals
- Hot gases
- Chlorine gas
- Methanol
- Propane
- Liquid nitrogen
- Oxygen
- Carbon monoxide & carbon dioxide
- Sewage
- Reausticizing
- White water
- River water
- Cooked starch
- Scrubber effluent
- Fly and bottom ash
- Gasoline
- Tail gases
- Off gases
- Sour gas
- Sea water

## XOMOX® HPBV Design Features

### Standard Features and Compliance

- TA-Luft 2021 certified
- ISO 15848-1: 2017, Class BH, level CO3 standard, SSAO
- EPA Method 21 (Fugitive Emissions Compliance)
- API 609 and ASME B16.34; EN 12016 valve design standard
- Zero leakage as per API 598; EN12266 leakage rate A
- Fire-Safe acc. to API 607 and EN ISO 10497:2000
- Quality certification as per ISO 9001
- CE-marking according to DGRL 2014/68/EU
- ISO 5211 actuator mounting bracket
- IEC61508 SIL 2 and 3
- CRN (Canada) certified
- TSG (China) certified

### Special Options

- Fire-Safe
- Leakage Detection
- Primary stem seal
- Oil-free/Grease-free (various designs as per customer request)
- Oxygen application
- Chlorine and phosgene applications
- Smooth seat retainer
- Cryogenic design & Steam traced discs
- Heating jackets + others up on request

Along with the XOMOX® 800 series, the XOMOX® high performance butterfly valve 800ISO (-R) is the only double offset design butterfly valve on the market with uninterrupted sealing surfaces that provide double dead-end service under full differential pressure.

The ISO mounting flange allows levers, gear mechanisms, and actuators to be mounted directly via a standardized ISO interface.

The one-piece body design that includes the stuffing box and mounting pad without intermediate openings and sealing surfaces allow the connecting piping and valve to be completely insulated while eliminating potential leak paths.

# XOMOX® HPBV 800ISO Flange Options

DN (mm)	NPS (in.)	EN 558								API 609 Table 3a ASME B16.10 Table 9 Column 7 MSS-SP-68 Table 1
		PN 10		PN 16		PN 25		PN 40		Class 150
		R20	R25	R20	R25	R20	R25	R20	R25	
80	-	•	•	•	•	•	•	•	•	-
100	-	•	•	•	•	•	•	•	•	-
150	-	•	•	•	•	•	•	•	•	-
200	-	•	•	•	•	•	•	•	•	-
250	-	•	•	•	•	•	•	•	•	-
300	-	•	•	•	•	•	•	•	•	-
350	14"	-	•	-	•	-	-	-	-	•
400	16"	•	•	•	•	-	-	-	-	•
450	18"	•	•	•	•	-	-	-	-	•
500	20"	•	•	•	•	-	-	-	-	•
600	24"	•	•	•	•	-	-	-	-	•

\* Larger sizes and higher pressure ratings available in Series 800 displayed in Technical Data Sheet.

# XOMOX® HPBV 800ISO Key Product Features



1

**Exclusive, flexible O-ring** inside the packing flange prevents dirt from entering the inside of the valve and the packing.

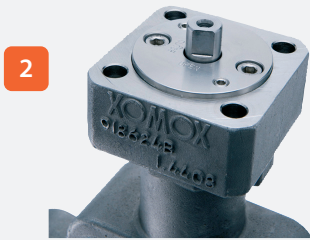

2

**DIN-ISO mounting head** permits the use of standardized ISO brackets for actuation. Also, actuation can be directly mounted on the valve more economically.



3

**Increased blow-out safety** is achieved through improved shaft design. Even if the tapered pin connection between shaft and disc is lost, the shaft is still in a stable position.



4

The LUG design comes standard with a screwed seat retainer, while the WAFER design features a smooth seat retainer. To meet diverse application needs, all valve designs can be equipped with clamped smooth seat retainers, bolted smooth retainers for double dead-end service, or standard bolted seat retainers.

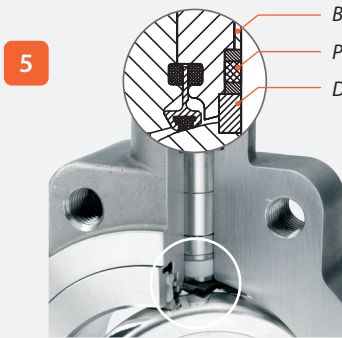

5

Bearing  
PTFE seal  
Disc Spacer Seal

The optional **disc spacer sealing** prevents dirt from entering the bearing area above and below the disc. This is especially important for sticky or dusty media, or media that tends to polymerize.



**6** **The extended body neck** enables standardized insulation. With thicker insulation, there is less heat loss, improving process efficiency.

**7** **The closed bottom of the valve body** eliminates a potential leak path. The increased safety improves economic efficiency of the plant. Starting with DN 350, an improved plug seal provides superior fugitive emissions control.

## XOMOX® HPBV Superior Sealing and Extended Service Life

An important feature of the seat is that it is axially pliant. Unlike other seats, it is not susceptible to radial stretch. When the valve opens, the seat flexes axially and returns to its original compact shape. It does not “relax” into the flow path. This seat design includes two components:

- 1 An outer segment of PTFE or R-PTFE.
- 2 A deformation-resistant, memory-core membrane.
- 3 The seat retainer covers the seat, protecting it from erosion and abrasion.

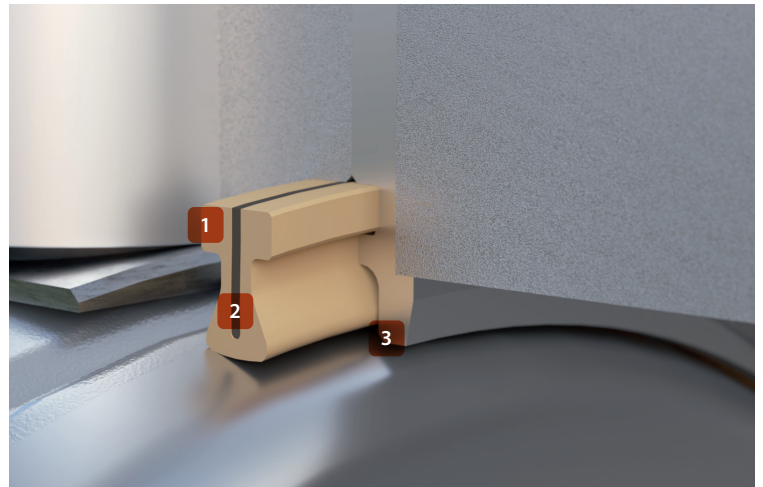

### Simply Superior

The genius is in its simplicity. There are no springs to break, O-rings to swell, or metal hoops to corrode. Installation is also simple and virtually error-proof. Two versions are available: soft and firesafe seat.

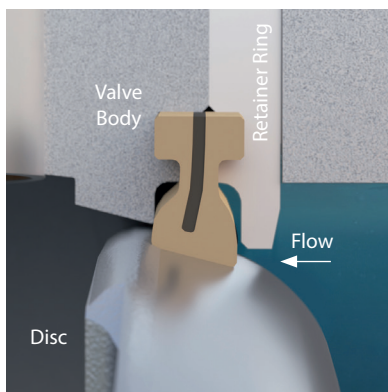

#### Valves closed, with right-to-left flow

The axial movement of the seat in the direction of the flow produces a pressure-assisted virtually leak-tight seal. (As line pressure increases, the seal tightens.) From vacuum through high pressure, tight shutoff is maintained.

Preferred flow direction for PTFE and R-PTFE seats, particularly for vacuum conditions.

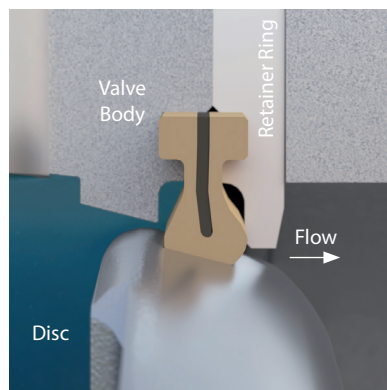

#### Valve closed, with left-to-right flow

Bi-directional flow and shutoff are easily accommodated. The same, simple, axial movement of the seat assures a reliable seal in either direction.

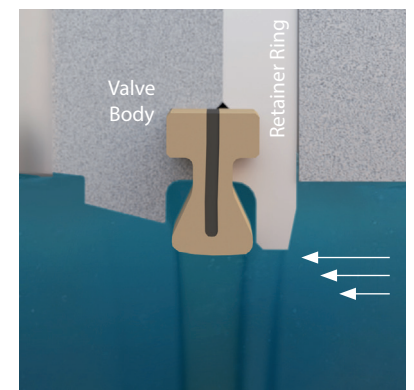

#### Valve open, with media flowing

To further extend seat life, the inside diameter of the retainer ring is smaller than that of the PTFE seat. This protects the seat from erosion and abrasion.

Even after 100,000 cycles the seat maintains a tight seal. The seat's internal pliant membrane is the “memory core” that inhibits radial deformation.

# XOMOX® HPBV Soft Seat Sealing with Fire-Tested Safety

For applications involving flammable media, the dual component seat offers both superior sealing and fire-tested security. It provides tightness according to leak rate A (EN12266-1) up to 300°C.

## Proven Performance

Numerous test results demonstrate that this valve meets or exceeds the requirements of API-607 4th edition as well as EN ISO 10497:20. The seat combines PTFE and metal sealing elements. The metal component is available in a variety of different alloys.

This seat establishes both a PTFE-to-metal seal and a dual metal-to-metal seal.

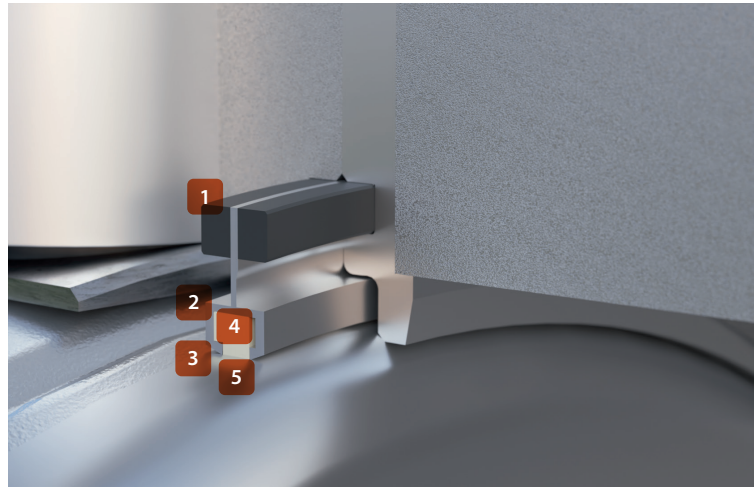

- 1 Seat sealing (graphite)
- 3 Metal-to-metal seal
- 5 PTFE-to-metal seal
- 2 Metal seat component
- 4 PTFE seat component

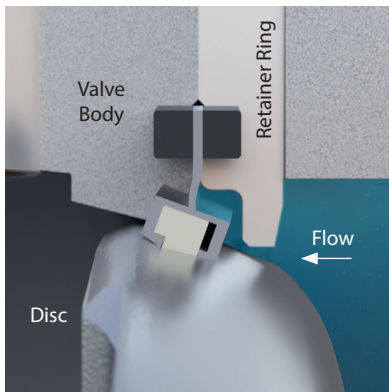

### Normal operation – right-to-left flow

This unique seat is designed for bidirectional flow control.

As pressure increases, the seat flexes axially in the direction of the flow. This tightens the seat contact with the disc for effective sealing.

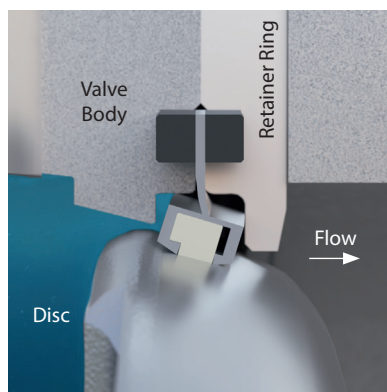

### Normal operation – left-to-right flow

Both the metal seat and the PTFE seat are in tight contact with the disc. As line pressure increases, the seal tightens axially.

Preferred flow direction for Firesafe and metal-to-metal seats.

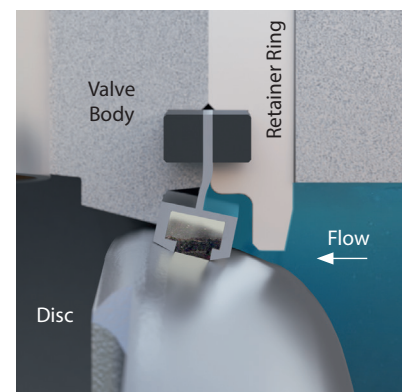

### Impact of fire

In case of fire, as the PTFE portion of the seat deteriorates, the metal portion of the seat maintains the integrity of the seal.

# XOMOX® HPBV 800ISO Coding - How to Order

## Coding - How to Order

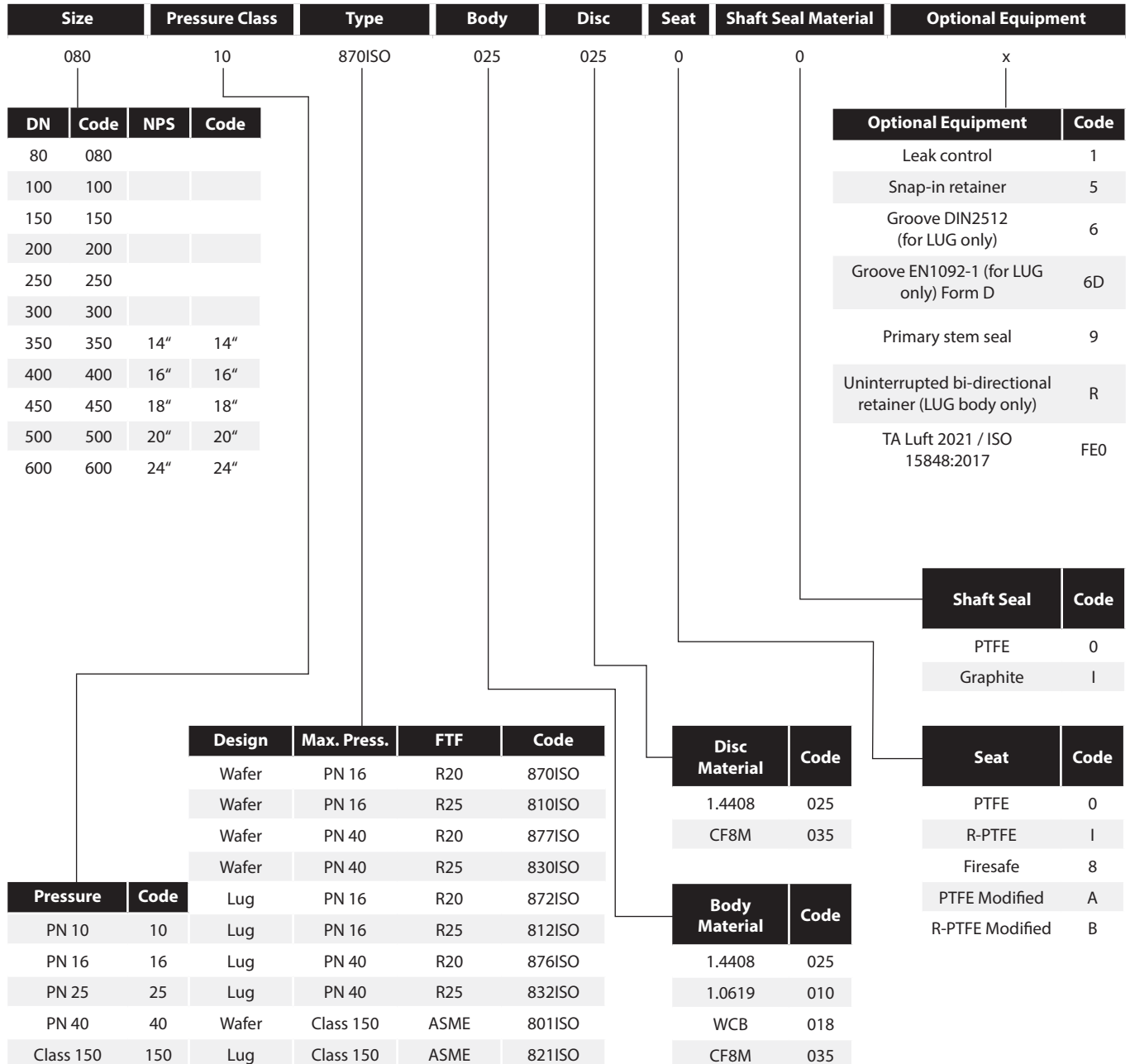

Optionally, the lug-design valves are available with a bolted seat retainer for double dead-end service. Larger sizes, higher pressure and temperature ranges, and ASME dimensions are still offered under our valve type "800". Special materials as per customer request are also provided under type "800".

# XOMOX® HPBV 800 Coding - How to Order

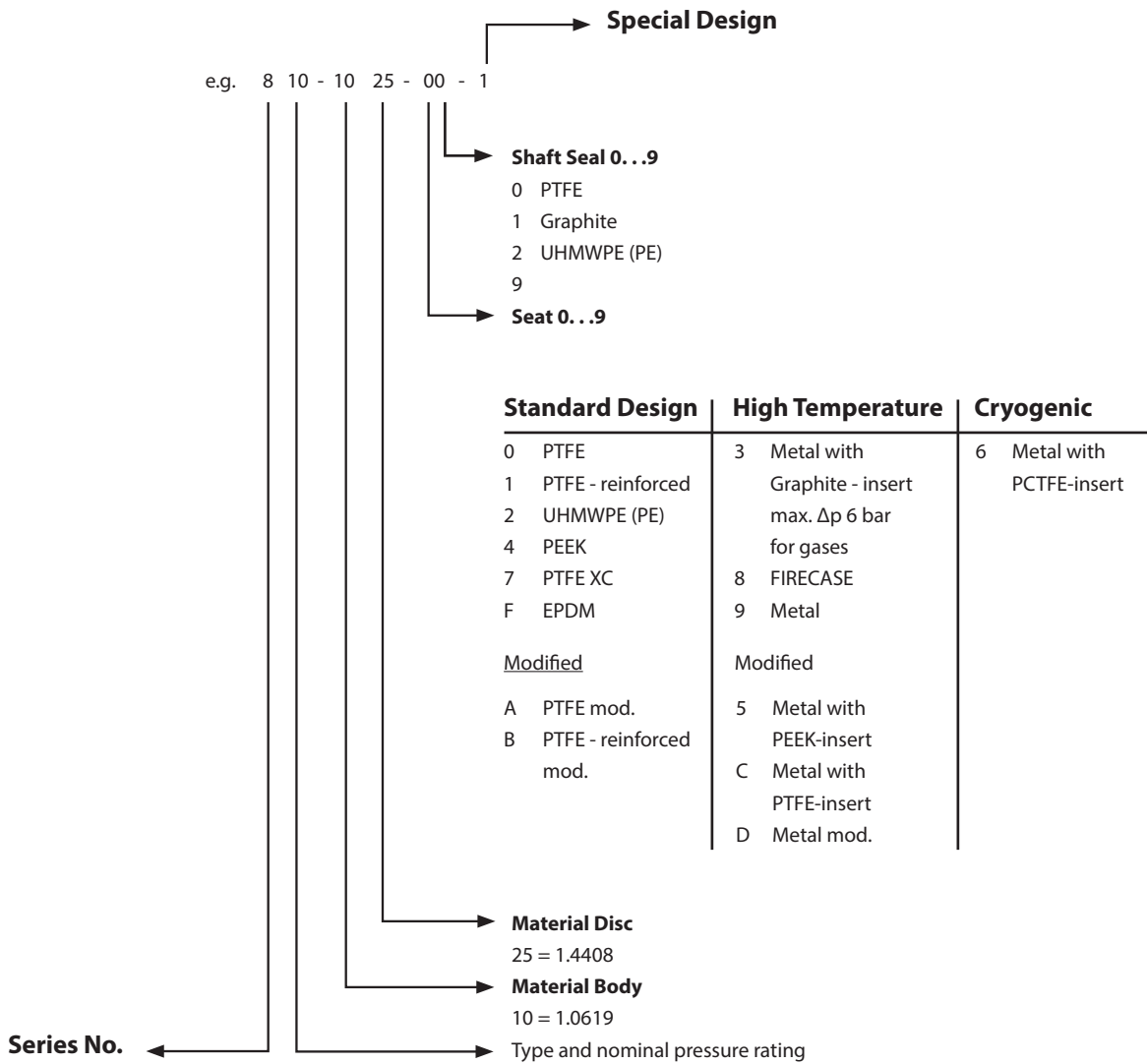

## Special Design

1	Leakage Drain Off
2	Extended Shaft Seal
3	Flanges to DIN ISO 5211 Actuator Mounting
4	Steam Traced Disc
5	Screwless Retainer Fixing (<DN 300)
6	Grooved Flange Faces DIN 2512* or 6D EN 1092-1
7	With Internal Travel Stop
8	Full cryogenic max. - 196°C
9	Disc Spacer Seals
K	Semi cryogenic max. - 100° C
L	Longer Taper Pins
Q1	Single Quadring Seal
Q2	Double Quadring Seal
V	Welded Plug

HR	Steam Jacket with Threaded Connections
HJ	Steam Jacket with Flanged Connections
6F	Tongue DIN 2512*
R13	Female-Faced Type R13-DIN 2513*
RJ	Ring Joint ASME B 16.5
LF	Large Female ASME B 16.5
LG	Large Groove ASME B 16.5
SG	Small Groove ASME B 16.5
VD	Plug with Safety Lock
EA	Grounding Connection
SA	Flushing Connection
FE0	TA-Luft 2021 / ISO 15848:2017

\* DN 50-100 and DN 150: Seat retainer fixed by roll pins.

## XOMOX® HPBV 800 Coding - How to Order

Material Number	Standard	XomoX-Material Code	Former / Alternative Specifications
1.4309 G-X2CrNi19-11	DIN 10213-4	067G	A2 1.4306 G-X2CrNiN189
1.4409 G-X2CrNiMo10-11-2	EN 10213-4	031	A4 1.4404 G-X2CrNiMoN1810
1.4552 G-X5CrNiNb10-11	EN 10213-4	028	A2
1.4400 G-X5CrNiMo 18 10	EN 10213-4	025	A4
Grade CD4MCuN	ASTM A 995	146	Duplex
Grade CN7M	ASTM A 351	178	Alloy 20
Grade CF8C	ASTM A 351	036	A2
Grade CF3	ASTM A 351	037	A2
Grade CF8	ASTM A 351	040	A2
Grade CF3M	ASTM A 351	038	A4
Grade CF8M	ASTM A 351	035	A4
3.7031 G-Ti2	DIN 17865	054	Titanium Casting unalloyed
3.7032	DIN 17865	054P	Titanium Casting with Pd
Grade C2	ASTM B 367	051	Titanium Casting

EN-JS1049 EN GJSF-400S-18S 5.3103	EN 1563	003	Ductile Iron GGG 40.3 0.7043
0.7659 GGGNiCrNb 20 2	DIN 1694	004	Ductile Iron austenitic
1.0038 S235JRG2	EN 10025	059	Unalloyed rolled-and forged Steel RS137-2
1.0425 P265GH	EN 10028-1	405	Unalloyed rolled-and forged Steel H11
1.0566 P355NL1	EN 10028T3	136	Unalloyed rolled-and forged Steel TStE355
1.0619 + QT GP240GH + QT	EN 10213-1/2AD W5	010	High Temp. Cast Steel 1.0619.05 GS-C 25 V
WCB	ASTM A216	018	High Temp. Cast Steel
1.1138.05	SEW 685	199	Low Temp. Cast Steel GS-21Mn5V
2.4365.01 G-NiCu30Nb	DIN 17730	145	Monel Casting
2.4170.01 G-Ni 95	DIN 17730	042	Nickel Casting
Grade CW-2M	ASTM A 494	021	Casting C4
Grade N-7M2	ASTM A 494	145	Casting B2
Grade CZ-100	ASTM A 494	050	Nickel Casting
Grade M-35-1	ASTM A 494	046	Monel Casting
2.0975	EN 1982	408/193	Alu-Bronze AB2 G-CuAl10Ni

**CRANE**®

---

**CRANE CHEMPHARMA & ENERGY**

Xomox International GmbH & Co.OHG  
Von-Behring-Straße 15  
88131 Lindau (Bodensee)  
Germany  
Tel.: +49 8382 702-0

Xomox Corp.  
4444 Cooper Road,  
Cincinnati, OH 45242  
USA  
Tel.: (513) 745-6000

---

Crane Company, and its subsidiaries cannot accept responsibility for possible errors in catalogues, brochures, other printed materials, and website information. Crane Company reserves the right to alter its products without notice, including products already on order provided that such alteration can be made without changes being necessary in specifications already agreed. All trademarks in this material are the property of the Crane Company or its subsidiaries. The Crane and Crane brands logotype (ALOYCO®, BAUM®, CENTER LINE®, CRANE®, CRYOWORKS®, DEPA® & ELRO®, DOPAK®, DUO-CHEK®, FLOWSEAL®, GYROLOK®, GO REGULATOR®, HOKE®, JENKINS®, KROMBACH®, NOZ-CHEK®, PACIFIC®, RESISTOFLEX®, XOMOX®, SAUNDERS®, STOCKHAM®, TECHNIFAB®, TEXAS SAMPLING®, WESTLOCK CONTROLS®, WTA®, and XOMOX®) are registered trademarks of Crane Company. All rights reserved.