

XOMOX[®]

HIGH
PERFORMANCE
BUTTERFLY
VALVES

SERIES 800ISO/800ISO FEO



DATASHEET

CRANE[®]



www.cranecpe.com

HPBV 800ISO Product Specifications

Product Details

Materials

- Standard: 1.0619, 1.4408; A216 Gr. WCB, A351 Gr. CF8M
- Optional materials upon request

Size Range

- DN 80 to DN 600 ; 3" to 24"

Pressure Ratings

- PN 10, 16, 25, 40; ASME Class 150

Temperature Range

- PTFE seat --> 204°C
- R-PTFE seat --> 232°C
- Fire-Safe seat --> 300°C

Body Configurations

- Lug design
- Wafer design

Standard Features and Compliance

- TA Luft 2021, ISO 15848 2017
- Fire-Safe acc. to API 607, 4th edition, and EN ISO 10497:2000
- DGRL 2014/68/EU
- See brochure for more information

Special Options

- Fire-Safe
- Leak control
- Primary stem seal
- Oil-free/Grease-free (various designs as per customer request)
- Oxygen application
- Chlorine and phosgene applications
- Sealed disc spacers
- Smooth seat retainer ring for double dead end service

Features and Benefits

1

Certified for Safety

Tested to TA Luft 2021 and ISO 15848: 2017, standards to ensure safe operation and prevent costly unplanned shutdowns.

2

Uninterrupted Sealing

The 800ISO (-R) design offers a continuous sealing surface for higher efficiency and bi-directional double dead-end service under full differential pressure.

Leak-Free Reliability

3

ISO mounting flange enables direct actuator installation, while the integral stuffing box eliminates extra leak paths compared to bolt-on designs.

4

Durability by Design

Unique axially pliant seat—no springs, o-rings, or metal hoops—delivers consistent bubble-tight shutoff and long-term reliability per EN 12266-1.

HPBV 800ISO Product Specifications

Sizes and Face-to-Face Dimensions

DN (mm)	NPS (in.)	EN 558								API 609 Table 2 ASME B16.10 Table 9 Column 7 MSS-SP-68 Table 1
		PN 10		PN 16		PN 25		PN 40		Class 150
		R20	R25	R20	R25	R20	R25	R20	R25	
80	-	●	●	●	●	●	●	●	●	-
100	-	●	●	●	●	●	●	●	●	-
150	-	●	●	●	●	●	●	●	●	-
200	-	●	●	●	●	●	●	●	●	-
250	-	●	●	●	●	●	●	●	●	-
300	-	●	●	●	●	●	●	●	●	-
350	14	-	●	-	●	-	-	-	-	●
400	16	●	●	●	●	-	-	-	-	●
450	18	●	●	●	●	-	-	-	-	●
500	20	●	●	●	●	-	-	-	-	●
600	24	●	●	●	●	-	-	-	-	●

Typical Applications

Industries and applications:

- Chemical and petrochemical
- Oil and gas
- Air separation
- Chlorine liquefaction
- Power generation
- Energy
- Offshore platforms
- Pulp & paper
- Desalination
- Steam
- Corn processing
- HVAC

Processes:

- Various chemicals
- Hot gases
- Chlorine gas
- Methanol
- Propane
- Liquid nitrogen
- Oxygen
- Carbon monoxide & carbon dioxide
- Sewage
- Reausticizing
- White water
- River water
- Cooked starch
- Scrubber effluent
- Fly and bottom ash
- Gasoline
- Tail gases
- Off gases
- Sour gas
- Hydrogen
- Ammonia
- Acrylic Acid

HPBV 800ISO Materials For DN 80-300 Standard Design

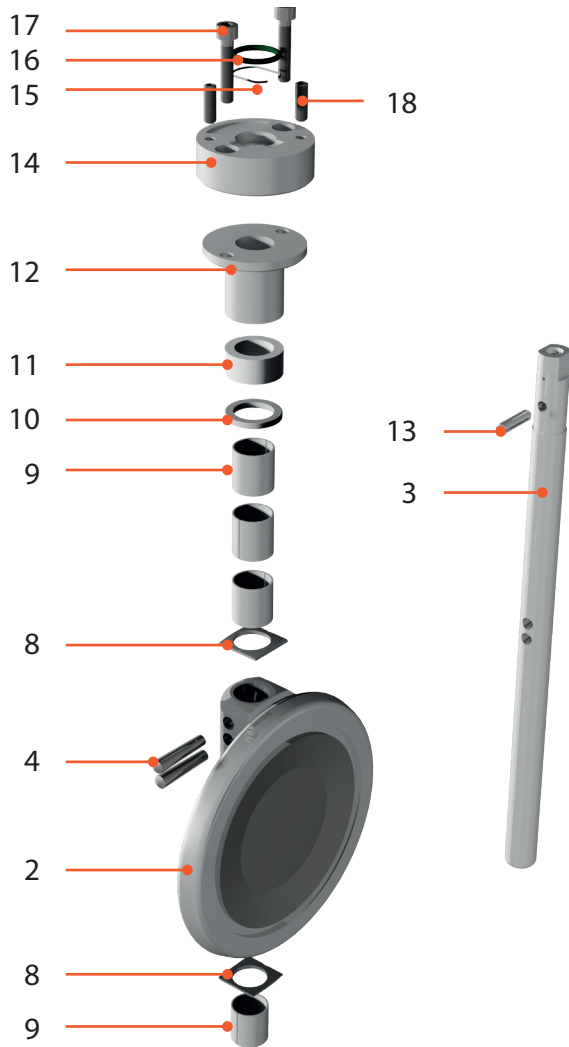

Pos. no.	Part	Material	
		Soft-seated	Firesafe
1	Valve body	1.4408 / 1.0619	1.4408 / 1.0619
2	Disc	1.4408	1.4408
3	Shaft	A564-630	A564-630
4	Tapered pin	A564-630	A564-630
5	Seat assembly	PTFE / R-PTFE	1.4571 / PTFE
6	Seat retainer	1.4408	1.4408
7	Hex socket cap screw	A4-70	A4-70
8	Disc spacer	1.4571 S4N	1.4571 S4N
9	Shaft bearing, rolled	1.4571 / PTFE	1.4571 / Ni-plated
10	Packing support ring	1.4571	1.4571
11	Packing set	PTFE	Graphite
12	Gland Follower	1.4571	1.4571
13	Locking pin	1.4310	1.4310
14	Packing gland	1.4408 / 1.4571	1.4408 / 1.4571
15	Antistatic spring	1.4310	1.4310
16	O-ring	FKM	FKM
17	Packing gland screw (hex socket cap screw)	A4-70	A4-70
18	Gland follower adjusting screw	A4-70	A4-70

* Bodies in carbon steel (1.0619/WCB) will be delivered with an anti-corrosive protection paint

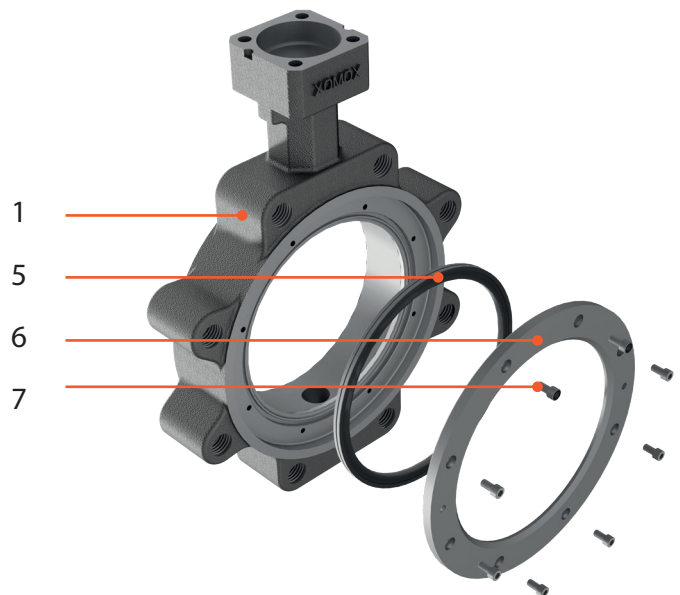

HPBV 800ISO Materials For DN 350-600 Standard Design

Pos. no.	Part	Material	
		Soft-seated	Firesafe
1	Valve body	1.4408 / 1.0619 CF8M / WCB	1.4408 / 1.0619 CF8M / WCB
2	Disc	1.4408 / CF8M	1.4408 / CF8M
3	Top shaft	A564-630	A564-630
4	Bottom shaft	A564-630	A564-630
5	Tapered pin	A564-630	A564-630
6	Disc spacer	1.4571 S4N	1.4571 S4N
7	Seat assembly	PTFE / R-PTFE	1.4571 / PTFE
8	Seat retainer	1.4571	1.4571
9	Hex socket cap screw	A4-70	A4-70
10	Shaft bearing, rolled	1.4571 / PTFE	1.4571 / Ni-plated
11	Packing support ring	1.4571	1.4571
12	Packing set	PTFE	Graphite
13	Gland follower	1.4571	1.4571
14	Packing gland	1.4408 / 1.4571	1.4408 / 1.4571
15	Antistatic spring	1.4310	1.4310
16	O-ring	FKM	FKM
17	Packing gland screw (hex socket cap screw)	A4-70	A4-70
18	Gland follower adjusting screw	A4-70	A4-70
19	Plug seal	PTFE	Graphite
20	Plug screw	A4-50	A4-50

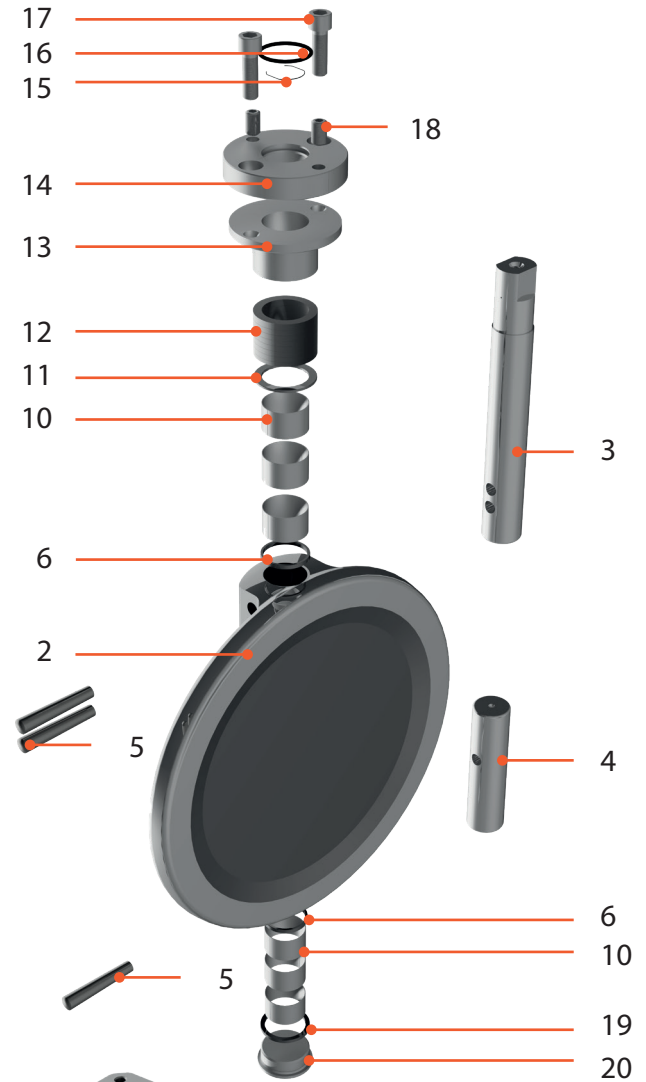

* Bodies in carbon steel (1.0619/WCB) will be delivered with an anti-corrosive protection paint

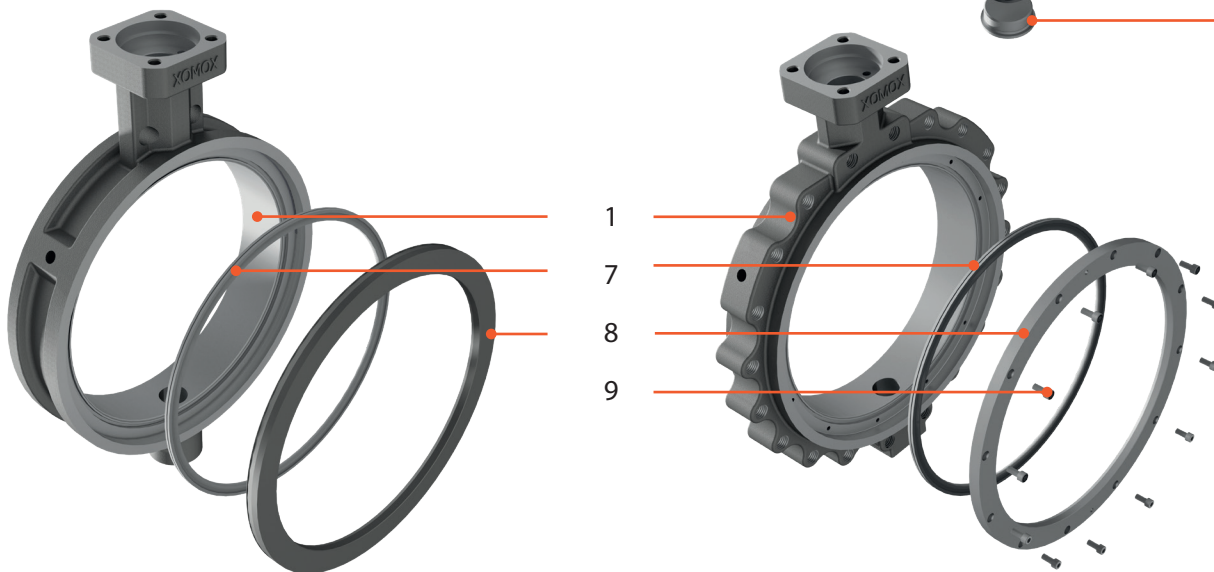

HPBV 800ISO Materials For DN80-300 TA-Luft Design FEO

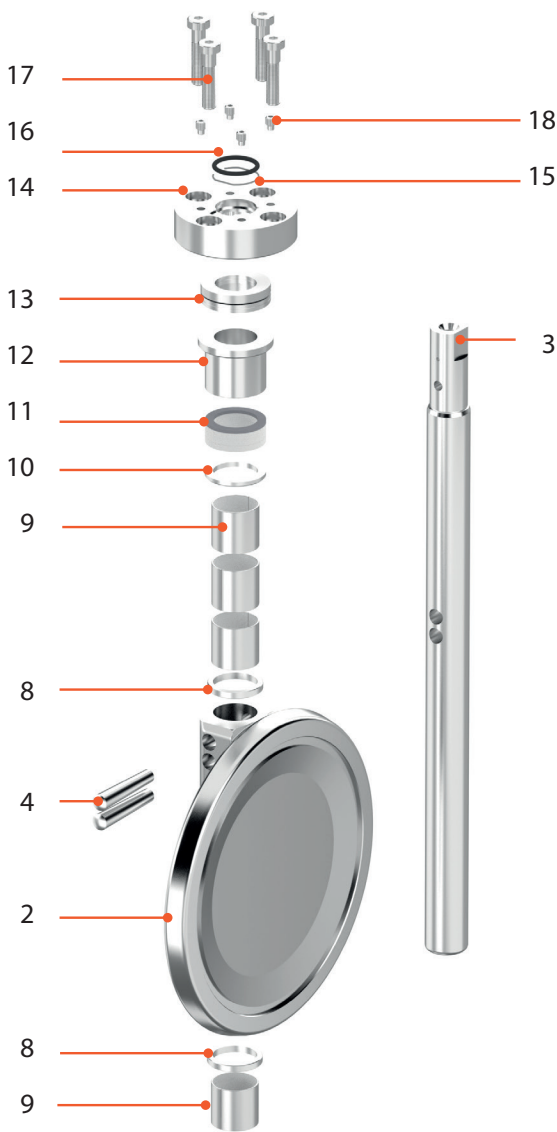

Pos. no.	Part	Material	
		Soft-seated	Firesafe
1	Valve Body	1.4408 / 1.0619 CF8M / WCB	1.4408 / 1.0619 CF8M / WCB
2	Disc	1.4408 / CF8M	1.4408 / CF8M
3	Shaft	A564-630	A564-630
4	Tapered pin	A564-630	A564-630
5	Seat assembly	PTFE / R-PTFE	1.4571 / PTFE
6	Seat retainer	1.4408	1.4408
7	Hex socket cap screw	A4-70	A4-70
8	Disc spacer	1.4571 S4N	1.4571 S4N
9	Shaft bearing	1.4571 / PTFE	1.4571 / Ni-plated
10	Packing support ring	1.4571	1.4571
11	Packing set	PTFE	Graphite
12	Gland follower	1.4571	1.4571
13	Beville spring set	1.4568	1.4568
14	Packing gland	1.4408 / 1.4571	1.4408 / 1.4571
15	Antistatic spring	1.4310	1.4310
16	O-ring	FKM	FKM
17	Packing gland screw (hex socket cap screw)	A4-70	A4-70
18	Beville spring adjust- ment screw	1.4980	1.4980

* Bodies in carbon steel (1.0619/WCB) will be delivered with an anti-corrosive protection paint

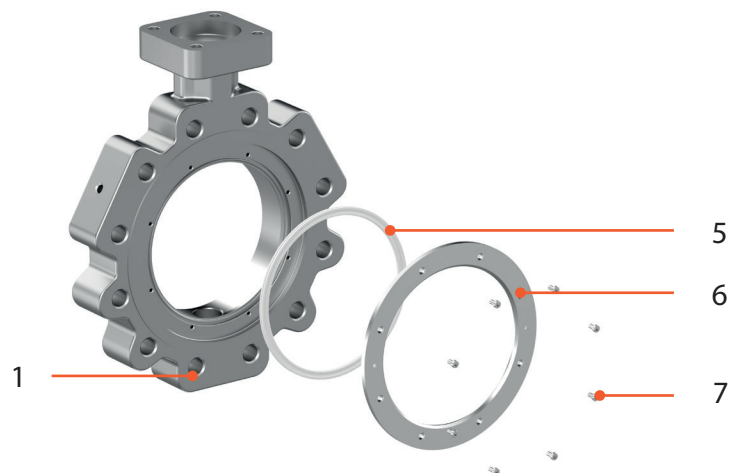

HPBV 800ISO Materials For DN 350-600 TA-Luft Design FEO

Pos. no.	Part	Material	
		Soft-seated	Firesafe
1	Valve Body	1.4408 / 1.0619 CF8M / WCB	1.4408 / 1.0619 CF8M / WCB
2	Disc	1.4408 / CF8M	1.4408 / CF8M
3	Top Shaft	A564-630	A564-630
4	Bottom Shaft	A564-630	A564-630
5	Tapered pin	A564-630	A564-630
6	Seat Assembly	PTFE / R-PTFE	1.4571/PTFE
7	Seat retainer	1.4408	1.4408
8	Hex socket cap screw	A4-70	A4-70
9	Disc spacer	1.4571 S4N	1.4571 S4N
10	Shaft bearing	1.4571 / PTFE	1.4571/CHNI
11	Packing support ring	1.4571	1.4571
12	Packing set	PTFE	Graphite
13	Gland follower	1.4571	1.4571
14	Beville spring set	1.4568	1.4568
15	Packing gland	1.4408 / 1.4571	1.4408 / 1.4571
16	Antistatic spring	1.4310	1.4310
17	O-ring	FKM	FKM
18	Packing gland screw (hex socket cap screw)	A4-70	A4-70
19	Beville spring adjustment screw	1.4980	1.4980
20	Plug seal	1.4571	1.4571
21	Plug Screw	A4-50	A4-50

* Bodies in carbon steel (1.0619/WCB) will be delivered with an anti-corrosive protection paint

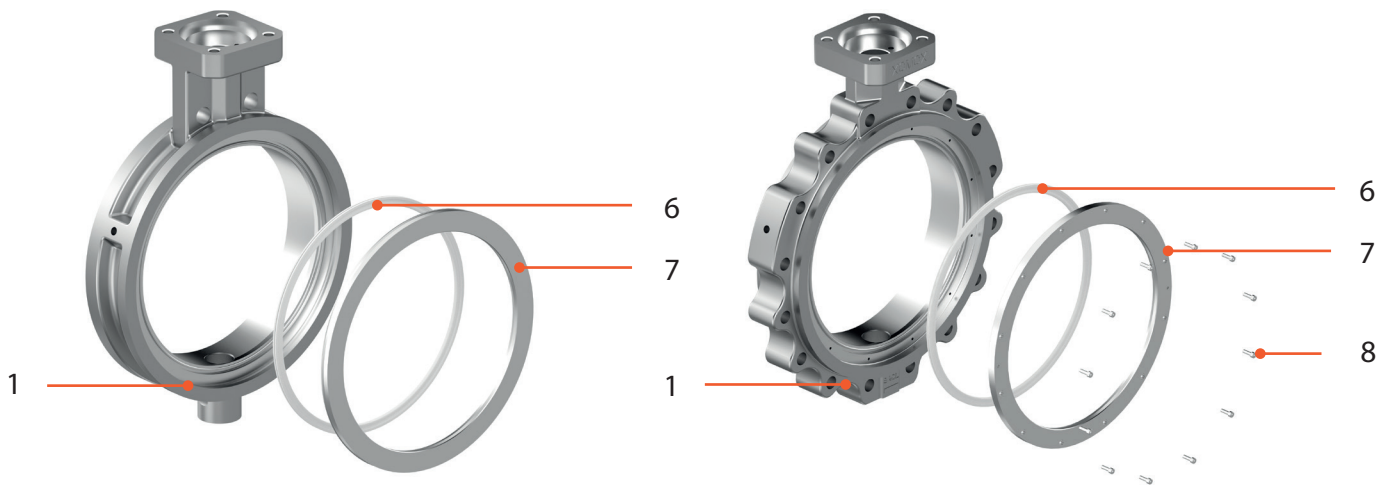
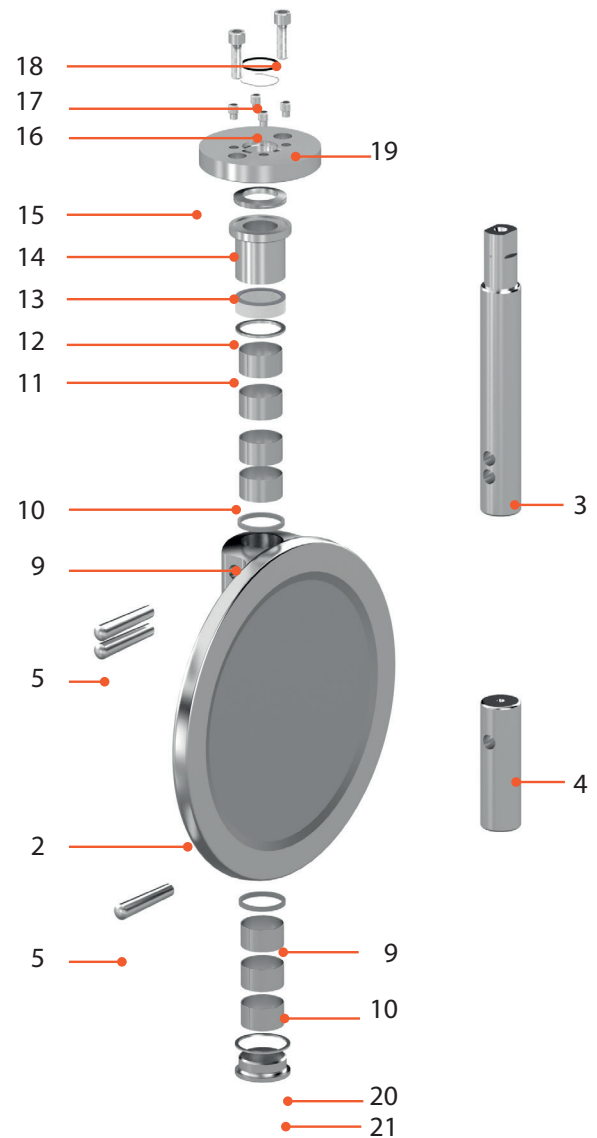

HPBV 800ISO Bare Stem Dimensions PN10/16 Class 150

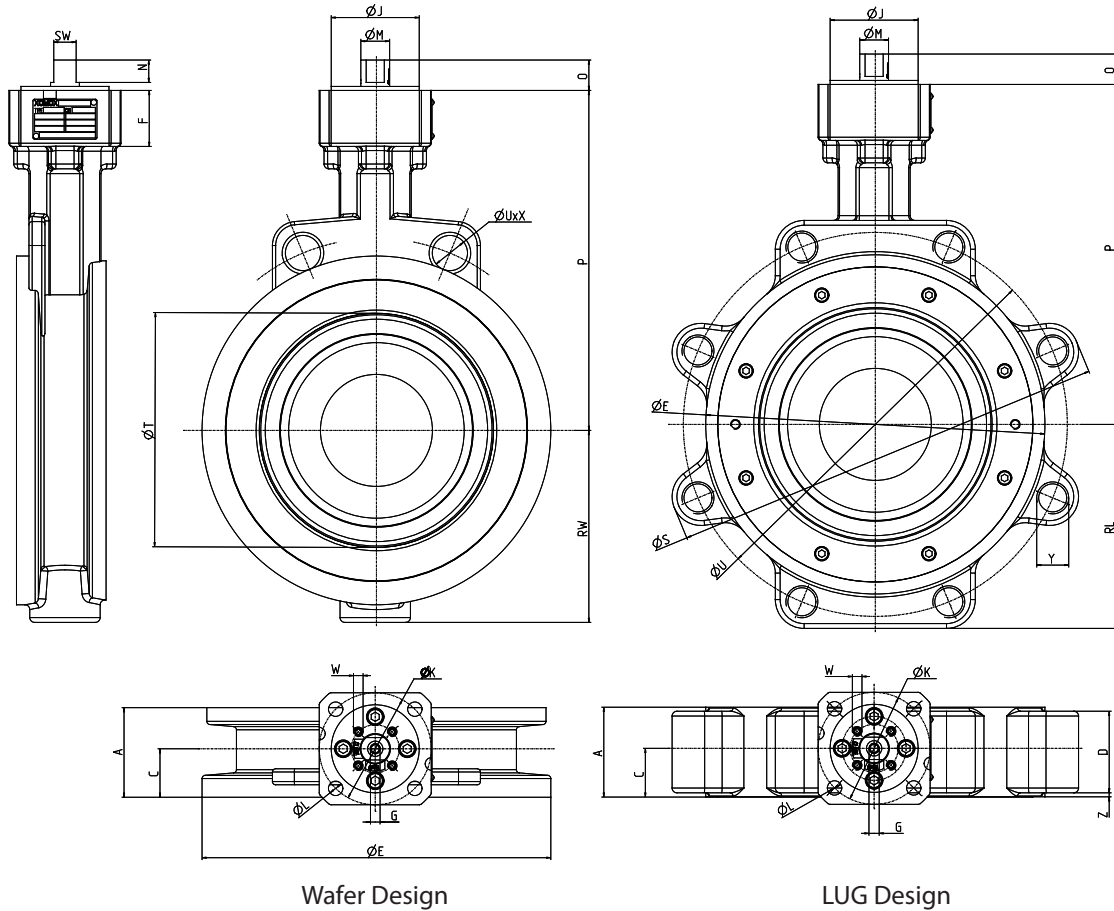

Wafer Design

LUG Design

Dimensions PN 10/16/Class 150 [mm]

DN	NPS	ISO flange	PN	Face-to-Face A			C	D	øE	F	G	øJ	øK	øL	øM	N	O
				R20	R25	ASME											
80	-	F05	10 - 16	46	49	-	23	36	142	30	M6	35	50	7.0	14	11	16
100	-	F07	10 - 16	52	56	-	26	45	162	33	M6	55	70	9.0	14	11	16
150	-	F07	10 - 16	56	70	-	30	51	218	35	M6	55	70	9.0	18	14	19
200	-	F10	10 / 16	60	71	-	33	54	273	34	M8	70	102	11.0	22	17	22
250	-	F12	10 / 16	68	76	-	39	56	328	36	M8	85	125	13.5	28	22	27
300	-	F14	10 / 16	78	83	-	45	62	378	38	M10	100	140	17.5	36	27	32
350	14"	F14	10/16/ CL150	not available	92		46	83	438	40	M10	100	140	M16	36	27	32
400	16"	F16	10/16/ CL150		102		50	64	489	43	M10	130	165	M20	36	27	33
450	18"	F16	10/16/ CL150		114		55	73	533	46	M10	130	165	M20	36	27	33
500	20"	F16	10/16/ CL150		127		62,5	70	590	52.5	M12	130	165	M20	48	36	42
600	24"	F25	10/16/ CL150		154		73	80	692	53	M12	200	254	M16	60	46	53

HPBV 800ISO Bare Stem Dimensions PN10/16 Class 150

DN	NPS	ISO flange	PN	P	RL	RW	øS	SW	øT	øU	W	øX	Y	Z			Weight Wafer / Lug [kg]
														R20	R25	ASME	
80	-	F05	10 - 16	170	90.0	78	192	11	79	160	M6	18	8 x M16	5.0	5.0	-	4.6 / 7.3
100	-	F07	10 - 16	180	100.0	90	212	11	102	180	M6	18	8 x M16	4.0	4.0	-	7.0 / 10.0
150	-	F07	10 - 16	213	130.0	120	278	14	146	240	M6	22	8 x M20	2.5	7.3	-	12.2 / 18.8
200	-	F10	10 / 16	240	167.5	145	339	17	190	295	M6	22	8 x M20 12 x M20	4.5	8.5	-	19.0 / 33.4
250	-	F12	10 / 16	273	196.5	179	405	22	235	350 355	M8	22 26	12 x M20 12 x M24	11.0	11.0	-	31.0 / 45.2
300	-	F14	10 / 16	300	220.0	205	454	27	281	400 410	M8	22 26	12 x M20 12 x M24	14.0	14.0	-	45.8 / 61.8
350	14"	F14	10/16/ CL150	360	271	271	515	27	331	460 470 476,2	M10	22 26 28,6	16 x M20 16 x M24 12 x 1"-UNC	5,5		-	72 / 110
400	16"	F16	10/16/ CL150	385	292.5	292.5	584	27	372	515 525 539,7	M12	26 30 28,6	16 x M24 16 x M27 16 x 1"-UNC	18		-	102 / 131
450	18"	F16	10/16/ CL150	415	316	316	630	27	420	565 585 577,8	M12	26 30 31,7	20 x M24 20 x M27 16 x 1 1/8"-8UN	18		-	127 / 181
500	20"	F16	10/16/ CL150	464	367	367	695	36	469	620 650 635	M16	26 33 31,7	20 x M24 20 x M30 20 x 1 1/8"-8UN	27,5		-	173 / 219
600	24"	F25	10/16/ CL150	521	426,5	426,5	820	46	561	725 770 749,3	M16	30 36 34,9	20 x M27 20 x M33 20 x 1 1/4"-8UN	33		-	276 / 358

HPBV 80ISO Lever & Gear Dimensions PN10-40

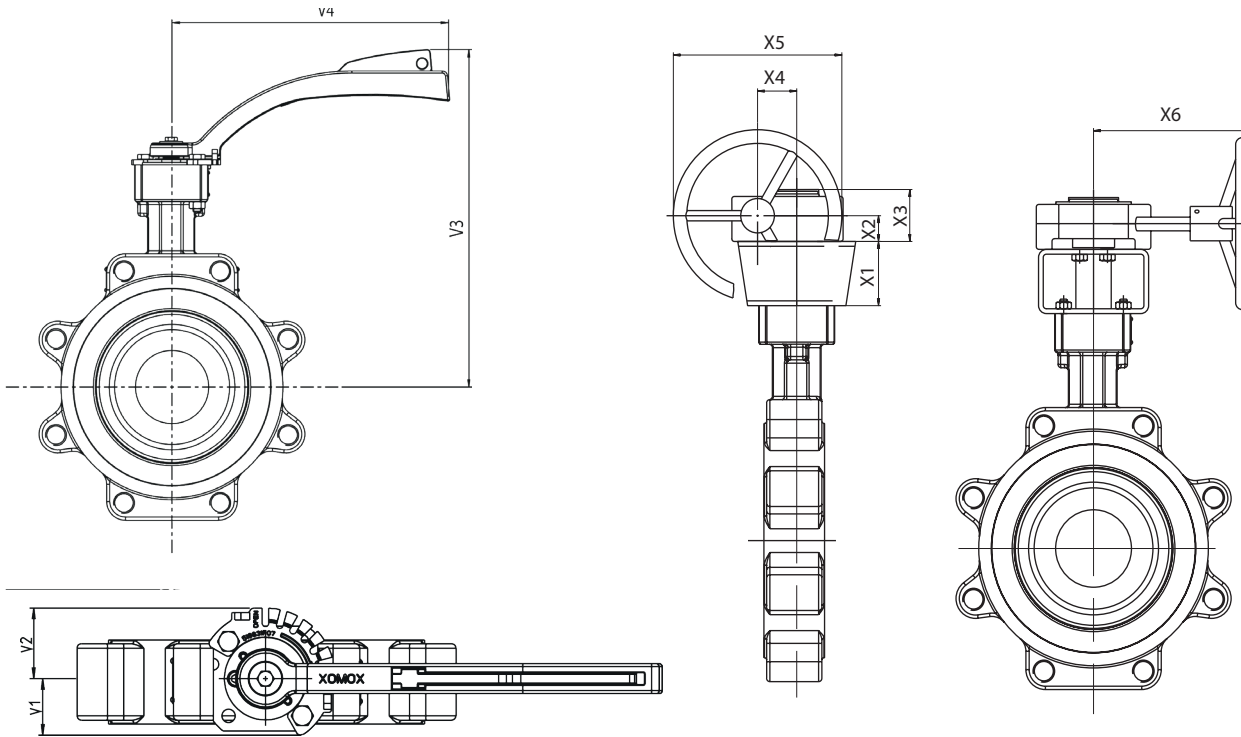

Valves with Latching Lever or Worm Gear DN 80 up to 600 / NPS 3" up to 24"

Dimensions PN 10-40 [mm]

DN	PN	Latching Lever					Manual Gear					
		V1	V2	V3	V4	Steps	X1	X2	X3	X4	X5	X6
80	10-16	33	33	266	170	5 x 18°*	60	27	58	39	150	133
	25-40	38	47	280	264	6 x 15°**	60	27	58	39	150	133
100	10-16	38	47	290	264	6 x 15°**	60	27	58	39	150	133
	25-40	38	47	298	264	6 x 15°**	60	27	58	39	150	133
150	10-16	38	47	322	264	6 x 15°**	80	35	67	52	203	163
	25-40	n/a	n/a	n/a	n/a	n/a	80	35	67	52	203	163
200	10-16	n/a	n/a	n/a	n/a	n/a	80	35	67	52	203	163
	25-40	n/a	n/a	n/a	n/a	n/a	80	42	81	67	305	200
250	10-16	n/a	n/a	n/a	n/a	n/a	80	42	81	67	305	200
	25-40	n/a	n/a	n/a	n/a	n/a	80	42	81	67	305	200
300	10-16	n/a	n/a	n/a	n/a	n/a	80	42	81	67	305	200
	25-40	n/a	n/a	n/a	n/a	n/a	100	50	94	90	457	267
350	10-16	n/a	n/a	n/a	n/a	n/a	80	42	81	67	305	200
400	10-16	n/a	n/a	n/a	n/a	n/a	100	50	94	90	457	267
450	10-16	n/a	n/a	n/a	n/a	n/a	100	50	94	90	457	267
500	10/16	n/a	n/a	n/a	n/a	n/a	100	50	94	90	457	267
							100	50	105	123	620	352
600	10/16	n/a	n/a	n/a	n/a	n/a	200	50	105	123	620	352
							200	50	126	154	750	377

* Closed / 18° / 36° / 54° / 72° / Open

** Closed / 15° / 30° / 45° / 60° / 75° / Open

HPBV 800ISO Bare Stem Dimensions PN25-40

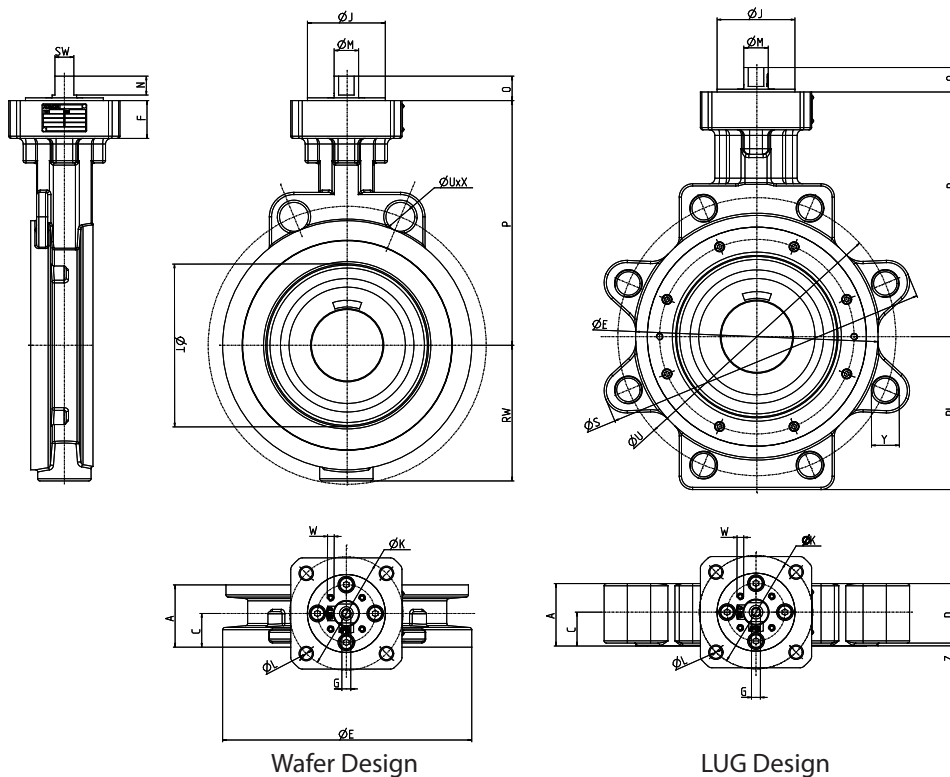

Dimensions PN 25/40 [mm]

DN	ISO flange	PN	Face-to-Face A			C	D	øE	F	G	øJ	øK	øL	øM	N	O
			R20	R25												
80	F07	25 - 40	46	49	23	41.0	142	33	M6	55	70	9.0	14	11	16	
100	F07	25 - 40	52	56	26	47.0	168	33	M6	55	70	9.0	18	14	19	
150	F10	25 - 40	56	70	30	53.5	224	34	M8	70	102	11.0	22	17	22	
200	F12	25 - 40	60	71	33	59.0	284	37	M8	85	125	13.5	28	22	27	
250	F14	25 - 40	68	76	39	64.5	340	40	M10	100	140	17.5	36	27	32	
300	F16	25 - 40	78	83	45	69.0	395	43	M10	130	165	22.0	36	27	32	

Dimensions (continued)

DN	ISO flange	PN	P	RL	RW	øS	SW	øT	øU	W	øX	Y	Z		Weight Wafer / Lug [kg]
													R20	R25	
80	F07	25 - 40	170.0	90	78	192	11	79	160	M6	18	8 x M16	3.0	3.0	5.5 / 7.9
100	F07	25 - 40	187.5	107	94	227	14	102	190	M6	22	8 x M20	3.0	3.0	7.5 / 11.4
150	F10	25 - 40	220.0	138	122	294	17	146	250	M6	22	8 x M24	2.5	2.5	14.7 / 22.8
200	F12	25/40	257.5	182	180	373	22	190	310 320	M8	26 30	12 x M24 12 x M27	1.0	1.0	26.4 / 43.4
250	F14	25/40	295.0	215	200	444	27	235	370 385	M8	30 33	12 x M27 12 x M30	4.0	4.0	41.3 / 65.2
300	F16	25/40	327.5	250	230	510	27	281	430 450	M8	30 33	16 x M27 16 x M30	9.5	9.5	60.8 / 95.0

HPBV 800ISO Design Parameters

Pressure-Temperature Rating

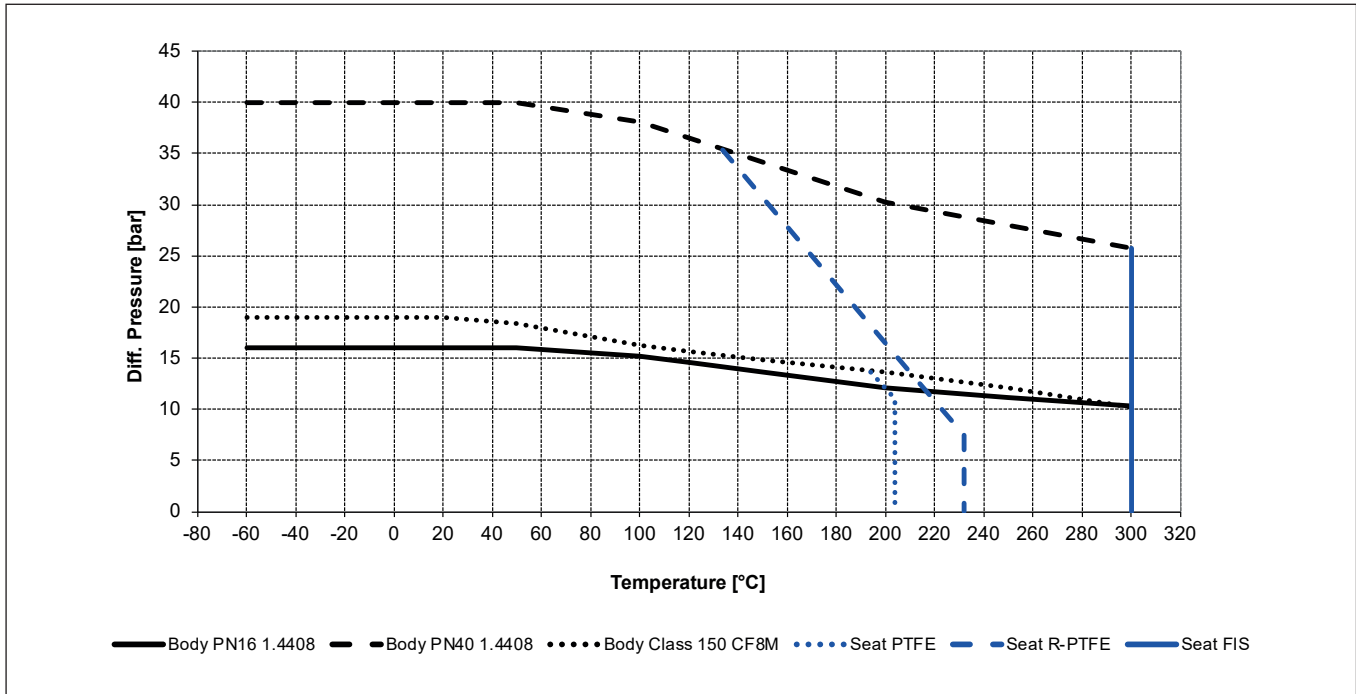

Torque Data

Diff. Pressure	Torque, PTFE Seat [Nm]			Torque, R-PTFE/FIS Seat [Nm]				
	7 bar	14 bar	20 bar	7 bar	14 bar	20 bar	28 bar	40 bar
80	24	31	37	29	36	43	52	68
100	39	50	61	46	60	72	90	115
150	96	120	146	115	140	175	225	299
200	181	226	277	217	270	330	425	579
250	289	352	443	346	435	530	690	940
300	430	543	661	516	650	790	1032	1416
350	588	735	900	625	850	1045	-	-
400	803	1006	1246	950	1155	1710	-	-
450	1006	1272	1590	1090	1590	2040	-	-
500	1289	1640	2037	1500	2200	2840	-	-
600	2046	2600	3210	2390	3385	4340	-	-

HPBV 800ISO Flow Characteristics

K_v Values PN 10/16 and Class 150

K _v Values at Various Disc Opening Angles [m ³ /h]						
DN	10 °	18 °	36 °	54 °	72 °	90 °
80	6	15	43	91	165	253
100	10	26	73	158	293	442
150	27	70	196	413	736	1154
200	47	120	335	709	1310	1980
250	74	191	532	1124	2080	3147
300	107	276	771	1628	2994	4627
350	153	380	1063	2245	4111	6325
400	193	482	1350	2852	5222	8034
450	265	662	1852	3914	7167	11026
500	330	826	2312	4865	8944	13760
600	446	1164	3260	6888	12611	19402

K_v values PN 25/40

K _v Values at Various Disc Opening Angles [m ³ /h]						
DN	10 °	18 °	36 °	54 °	72 °	90 °
80	5,1	13	37	79	144	222
100	9,4	24	66	144	264	406
150	26	64	178	376	689	1060
200	46	115	322	681	1247	1919
250	72	181	505	1068	1955	3066
300	104	262	732	1547	2833	4359

$$C_v [\text{gal/min}] = K_v * 1.156$$

HPBV 800ISO Design Parameters

Seat Tightness

For PTFE, R-PTFE and Firesafe seats:
Leak rate A according to EN 12266-1.

Vacuum Service

Standard: 3.33×10^{-2} mbar
Special: 1.33×10^{-6} mbar

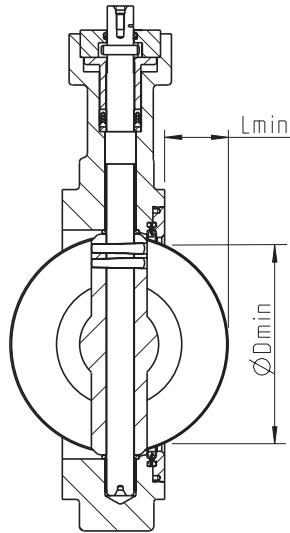

Minimum Pipe Diameter For Connecting Flanges

Minimum pipe diameter for connecting flanges			
DN	ØDmin R25 [mm]	ØDmin R20 [mm]	Lmin [mm]
80	73	74	20
100	96	97	30
150	141	146,5	50
200	186	194	70
250	233	243	90
300	280	289	111
350	330	330	125
400	370	370	140
450	420	420	160
500	470	470	180
600	560	560	220

HPBV 800ISO Product Coding

Coding - How to Order

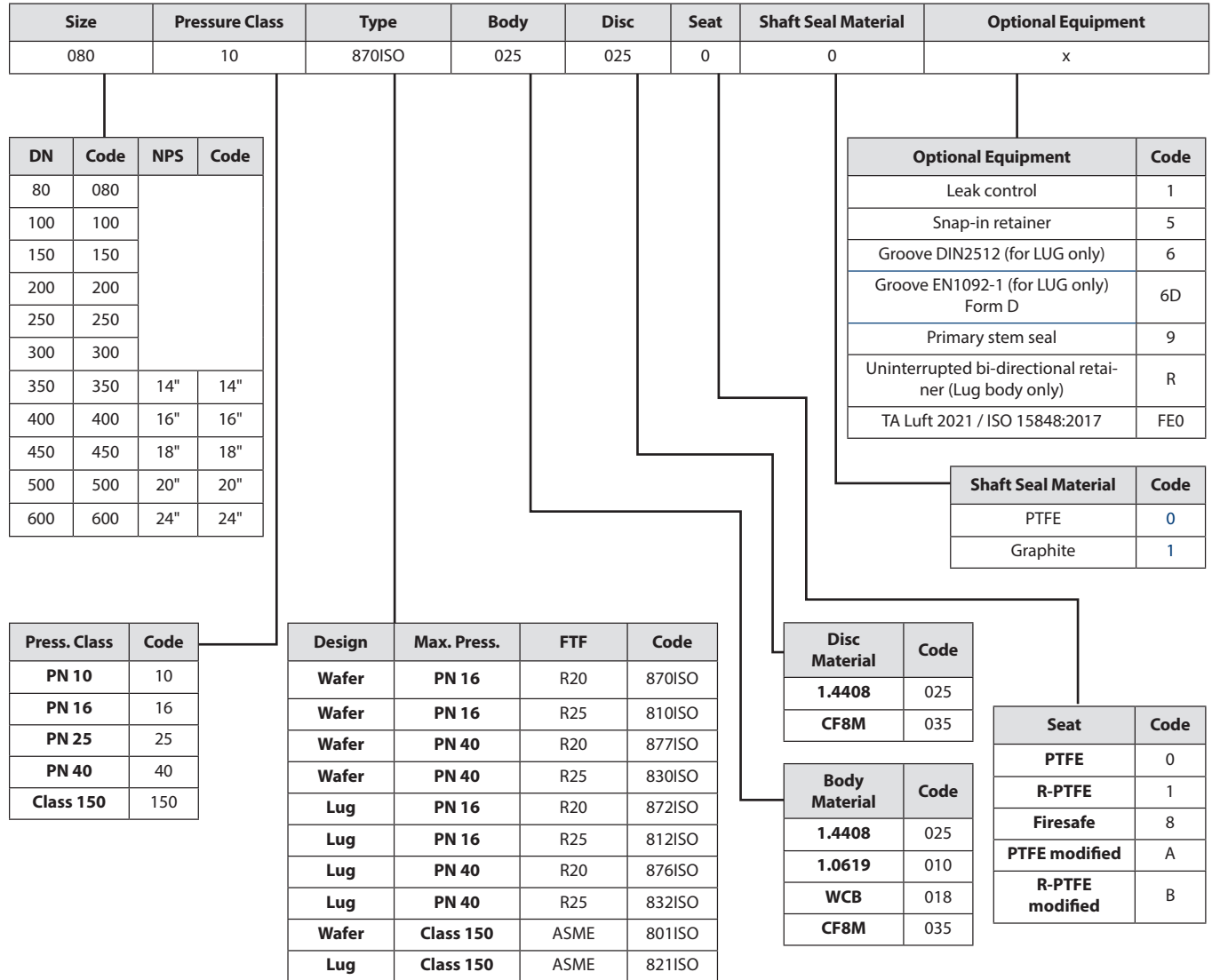

Optionally, the lug-design valves are available with a bolted seat retainer for double dead-end service. Larger sizes, higher pressure and temperature ranges, and ASME dimensions are still offered under our valve type "800". Special materials as per customer request are also provided under type "800".



CRANE CHEMPHARMA & ENERGY

Xomox International GmbH & Co.OHG
Von-Behring-Straße 15
88131 Lindau (Bodensee)
Germany
Tel.: +49 8382 702-0

Xomox Corp.
4444 Cooper Road,
Cincinnati, OH 45242
USA
Tel.: (513) 745-6000

Crane Company, and its subsidiaries cannot accept responsibility for possible errors in catalogues, brochures, other printed materials, and website information. Crane Company reserves the right to alter its products without notice, including products already on order provided that such alteration can be made without changes being necessary in specifications already agreed. All trademarks in this material are the property of the Crane Company or its subsidiaries. The Crane and Crane brands logotype (ALOYCO®, BAUM®, CENTER LINE®, CRANE®, CRYOWORKS®, DEPA®& ELRO®, DOPAK®, DUO-CHEK®, FLOWSEAL®, GYROLOK®, GO REGULATOR®, HOKE®, JENKINS®, KROMBACH®, NOZ-CHEK®, PACIFIC®, RESISTOFLEX®, XOMOX®, SAUNDERS®, STOCKHAM®, TECHNIFAB®, TEXAS SAMPLING®, WESTLOCK CONTROLS®, WTA®, and XOMOX®) are registered trademarks of Crane Company. All rights reserved.