

XOMOX®

HIGH PERFORMANCE BUTTERFLY VALVES

SERIES 800ISO/800ISO FEO



OPERATING AND MAINTENANCE INSTRUCTIONS

CRANE

v in

www.cranecpe.com

Table of Contents

General Info & Safety Considerations 3

General Valve Description and Variants 6

Series 800 ISO TALuft 2021 Compliant 7

List of Components 8

Repair Instructions 9

Troubleshooting 15

General Information and Safety Considerations

Introduction

These instructions are to support the user with installation, operation and maintenance of valves.

⚠ Caution

If the subsequent caution- and warning comments are not adhered to, danger can result thereof and the guarantee of XOMOX becomes null and void. XOMOX is at your disposal for further requests, for addresses see last page.

⚠ Danger

Safeguard against improper use of the valve:
It must be particularly ensured that the selected materials of the wetted parts of the valve are suitable for the used media. **Ignorance of these precautionary measures can mean danger for life and limb and cause damage in the piping system.**

1. Intended Use

Butterfly valves of the series 800 and 800ISO are only intended to lock, pass through or control the flow, after the installation into a pipeline system between the flanges PN 6 to PN 100 or Class 150 to Class 600 and after the set-up of the manual operating possibility or after the connection of the actuator to the control media within the permissible pressure- and temperature limits. These butterfly valves are not recommended for media with a high portion of abrasive solid materials.

The permitted pressure- and temperature range is described in the technical data sheets.

⚠ Caution

If a valve with differential pressures larger than approx. 0.15 bar (liquid media) is used for the controlling in the continuous operation, the system limits are to be observed in accordance with XOMOX-data sheet.

2. Safety Notes

2.1. General Safety Notes

The same safety regulations apply for valves as for the piping system in which they are installed and as for the control system to which the actuator is connected. The instructions available provide only such safety notes which are to be observed additionally for valves.

For actuator units additionally safety notes are contained in the respective operating instructions.

2.2. Safety Notes for the Operator Instructions.

It is not within the responsibility of XOMOX, and thus when using the valve, to ensure that

- the valve is used as intended in such a way as described in the Section 1

- An actuator or a manual operating possibility which has been installed subsequently onto the valve, and adjusted to the valve is adjusted correctly in both end positions of the valve.
- The piping system and the control system were assembled professionally and are checked regularly. The wall thickness of the body of the valve is dimensioned in such a way that in such professionally assembled lines the usual piping-additional forces and moments are taken into account.
- The valve is connected professionally to these systems.
- In this piping system the usual flow speeds are not exceeded in the continuous operation, and abnormal operation conditions such as oscillations, water shocks, cavitation and larger portions of solid materials in the medium – in particular abrasive – are to be agreed upon with the Manufacturer XOMOX.
- Valves which are operated at operating temperatures $>50^{\circ}\text{C}$ or $<-20^{\circ}\text{C}$ are protected together with the piping connections against being touched.
- Only for pressure-conducting pipelines, qualified employee operates, services and repairs the valve.
- No marking according to directive 94/9/EG (ATEX)

XOMOX® valves were examined in the scope of the directive 94/9/EG regarding of an assessment of danger of ignition in accordance with DIN EN 13463-1 2002.

The valves exhibit no own potential ignition sources and do not fall thus under the requirements of the directive. A CE marking following this directive is not permissible. The valves can be used in a potentially explosive area.

The valve has to be included into the electric potential analysis of the plant with regard to all metal parts in potentially explosive atmospheres independently of the guideline.

General Information

2.3. Special Types of Danger

⚠ Danger to Life

The butterfly valve shaft is sealed by a compression gland. Before the nuts are loosened at the gland, the **pressure in the pipeline must be completely diminished**, so that no media escapes from the compression gland.

⚠ Danger to Life

Before loosening the screw connection (or the cover) at the body or before dismantling the valve from the pipeline, the **pressure in the pipeline must be completely diminished**, so that the media does not escape unchecked from the line.

⚠ Danger

For valves, which are used as end valve: During normal use, in particular with gas-like, hot and/or dangerous media a blind flange must be mounted at the **free connecting pieces or the valve must be securely locked** in „CLOSE“-position.

⚠ Danger

If a valve has to be opened as end valve in a pressure containing line, this may take place with all caution only in such a way that **the spurting media** does not cause any damage.

⚠ Danger

If a valve must be disassembled from a pipeline, media can escape from the line or from the valve. With unhealthy or dangerous media the pipeline must be completely emptied before the valve is disassembled. Caution with residues which **reflow from the line or which have remained in body** cavities of the valve (under pressure).

2.4. Marking of the Valve

We mark the valve according to EN 19 or on customer request. Markings may not be damaged, that the valve can be identified.

3. Transport and Storage

Valves must be treated, transported and stored carefully:

- The valve is to be stored in its protective package and/or

with the protective caps at the connection ends. Valves which are heavier than approx. 10 kg, should be stored and transported on a pallet (or similar supported) (also to the installation place).

- With storage before installation, valve, gear and actuator are to be protected from damaging influences such as dirt or humidity and are to be stored at ambient temperature.
- Particularly the actuator, the gear and the ends of the valve to the piping connection may neither be damaged through mechanical nor other influences.
- Valves must be stored in such a way as they were supplied. The operating device may not be activated.

⚠ Danger

Only valves, which are supplied with free shaft end: The valve must be transported with the utmost care: the unsecured butterfly valve disk can open by itself out of the locking position due to effect from outside.

⚠ Caution

Only valves with actuator type „safety position „OPEN“ In the delivery state the butterfly valve disk protrudes on both sides from the body. The protruding rim of the butterfly valve disk has to be protected against damage: If the packing surface at the disk rim is damaged, the butterfly valve is no longer leak-proof!

4. Installation Into the Piping

4.1. General Instructions

For the installation of valves into a piping, the same instructions apply as for the connection of pipes and similar piping elements. For valves, the subsequent instructions apply additionally. For the transport to the installation place also the Section 3 (above) is to be considered.

⚠ Caution

The packing surfaces at the body of the butterfly valve are constructed in such a way that the flange sealings are to be used in accordance with EN1514-1 or ANSI B16.21. Counter flanges must have smooth packing strips, e.g. form A or B according to standard EN 1092. Other flange forms are to be agreed with the manufacturer XOMOX.

General Information

⚠ Danger

In order to avoid leakage at the flange connection:
Only suitable flange sealings may be used for the flange connections. Flange sealings made of elastomer may not be used.

⚠ Danger

The actuator is adjusted for the operating data indicated in the order: **The adjustment of the final impacts „OPEN“ and „CLOSE“** may not be changed without agreement of XOMOX.

⚠ Danger to Life

If – in special circumstances – a valve must be mounted without operating possibility, it is to be ensured that such a valve is not pressurized. If an actuator unit is retrofitted, torque, rotation direction, operating angle and the adjustment of the final impacts „OPEN“ and „CLOSE“ must be adapted to the valve.

Ignorance of these precautionary measures can mean danger for life and limb and cause damage in the piping system.

⚠ Caution

Only for valves with electric actuator:
It is to be ensured that the valve in the „CLOSE“-position is switched off **by the signal of the torque switch**.
In the position „OPEN“ the butterfly valve must be switched off **with the signal of the limit switch**.
For further information, see the operating instructions of the electric drive.

⚠ Danger to Life

No valve may be installed whose approved pressure-/temperature range (=„Rating“) is not sufficient for the operating condition: This approved range is described in the technical data sheet tdb_800_de -see Information. **Ignoring these regulations could mean danger for life and limb and cause damage to the piping system.** In the case of doubt the Manufacturer XOMOX is to be consulted.

- The counter flanges of the piping must be aligned and parallel to the plane. They must have an inner diameter with sufficient space for the opened butterfly valve, so that the butterfly valve is not damaged when swivelling out.
- Valves in general must be installed without any influence of stress, for example bending, from the pipeline. Both thermal expansion as well as vibrations of the pipelines have to be eliminated by compensators.
- Before the installation, the valve and the subsequent piping must be cleaned carefully of dirt, in particular from hard foreign substances, like welding debris.

⚠ Danger

Only butterfly valves with actuator „Safety position OPEN“:
For the installation the opened butterfly valve disc with control media must be closed and inserted into the line in completely closed state and bolted.

It must be ensured that for this installation process a supply with control media is available with full actuating pressure for the closing of the butterfly valve.

4.2. Assembly Order

- Take valve in the protective package to the installation place and remove valve from bag only there.
- Examine valve, gear and actuator for transport damage. Damaged units may not be installed.
- Ensure that only valves are installed whose pressure class, type of connection and connection dimensions correspond to the application conditions. The connection data for the actuator must correspond with the data of the control. See labelling at the actuator.
- Butterfly valves of the series 800/800ISO can be installed generally independently from the flow direction. In order to protect the seat ring.
- It is recommended to install the valve in such a way that a direction of arrow marked at the body (if available) corresponds with the flow direction.
- The preferred installation position is the one with horizontal flap shaft. The actuator is however to be arranged – if possible– not directly underneath the valve: Compression gland sealings can damage the actuator.
- When inserting the valve (and the necessary sealings) in

General Information

an already mounted pipeline the distance between the piping ends must be dimensioned in such a way that all connection- and/or sealing surfaces (and gaskets) remain undamaged.

Caution

The valve must be inserted with completely closed butterfly valve disk into the gap between the pipeline ends: Otherwise the flap disk could be damaged and the valve might no longer be leak-proof.

- During installation, the butterfly valve is centered by means of the flange screws.

Caution

Butterfly valves series 800 and 800ISO need screws of partly different lengths for the connection to the counter flanges. For dimensions of the flange screws see data sheet.

- The torque for tightening the flange bolts depends on the flange gasket and the operating conditions. Please refer to installation guidelines of gasket manufacturer. Flange bolts need to be tightened cross-wise to ensure equal pressure on the entire flange surface. For torque values, refer to data of gasket manufacturer.
- For the connection of the actuator unit to the control, the appropriate instructions apply.
- At the end of the installation a functional test with the signals of the control needs to be performed with the actuated valves: The valve must close and open correctly according to the control commands. Failures of correct functions must be corrected before putting the unit in service. See also Section 7 <Help with faults>.

Danger

Faulty executed control commands could **mean danger for life and limb and cause damage to the piping system.**

5. Pressure Test of the Piping Section

For the pressure test of the valves the same instructions apply as for the piping. Additionally applies:

- Rinse new installed line systems carefully in order to wash out foreign substances.
- The pressure test of an opened valve may not exceed the value 1,5 x PN/PS.
- A closed valve may be tested under pressure PT only with 1,1 x PN/PS (according to marking)

6. Normal Operation and Maintenance

The valves are to be operated manually or with the signals of the control. Valves which were supplied ex factory with actuator or gear are exactly adapted and may not be adjusted as long as a valve operates perfectly.

For the manual operation or the hand emergency operation at the actuator (if available) normal hand force is sufficient; the usage of extension for the increase of the actuation moment is not permissible.

For the manual operation or the hand emergency operation at the actuator (if available) normal hand force is sufficient; the usage of extension for the increase of the actuation moment is not permissible. In such cases the Section 2 <Safety information> and Section 7 <Faults> are to be observed.

Danger

A butterfly valve is not self-locking:
The operating possibility may not be dismantled **as long as the butterfly valve is pressurized.**

Danger

A butterfly valve is not self-locking:
Piston drives need **a constant supply with control pressure** for all positions which are started up under control pressure.

High Performance Butterfly Valves Models and Variants

XOMOX® High Performance Butterfly Valves (HPBV) are produced in a variety of models and options to best serve the needs of every specific application. This IOM covers one out of the two available valve models, Series 800 and 800 ISO. Both these models are currently designed to meet TA-Luft 2021 and certified as per ISO 15848:2017 to ensure outstanding performance with regards to Fugitive Emissions.

Series 800 & 800ISO valves are available in a wide array of configurations. This manual covers a few most commonly found options.

The model outlined in the instructions is the series 800ISO valve, designed without a bottom plug to minimize potential leak paths. It features an elongated neck to accommodate thicker insulation, along with several other premium design elements. These valves are manufactured in Europe and can be supplied with either a bolted seat retainer ring — accessible from the front or back for bi-directional dead-end service — or a Snap-In seat configuration.

The series 800 is available with a plug for bottom drain or with a bolted plate. These valves are also available with a bolted

seat retainer ring that is typically used in bi-directional dead-end applications, or with a snap-in seat retainer ring that provides a smooth sealing surface for the flange gasket to ensure a more efficient performance.

Both mentioned models offer an option to fit them with a fire-safe seat that is mounted in a slightly different way than the standard PTFE seat. All these options are covered in this IOM in the section corresponding to the assembly instructions for the Series 800ISO valves. For the assembly of series 800, please refer to the respective IOM of that model on the Crane website or through your local Crane representative.

For valves sold prior to the release of the 2021 version of TA-Luft, please contact your local Crane representative for the instructions manual.

Series 800 ISO Components

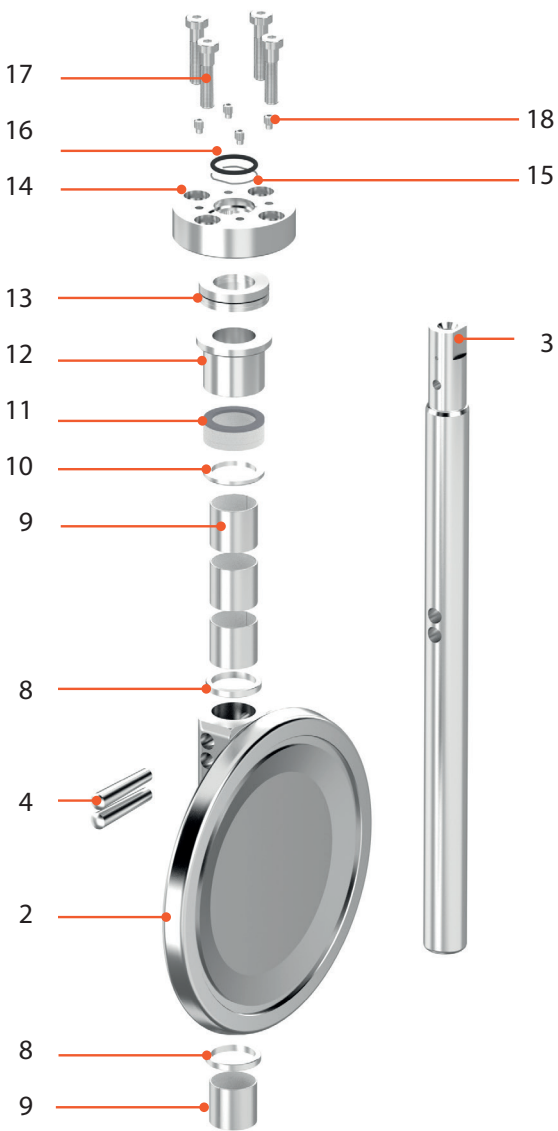

Pos. no.	Part	Material	
		Soft-seated	Firesafe
1	Valve Body	1.4408 / 1.0619 CF8M / WCB	1.4408 / 1.0619 CF8M / WCB
2	Disc	1.4408 / CF8M	1.4408 / CF8M
3	Shaft	A564-630	A564-630
4	Tapered pin	A564-630	A564-630
5	Seat assembly	PTFE / R-PTFE	1.4571 / PTFE
6	Seat retainer	1.4408	1.4408
7	Hex socket cap screw	A4-70	A4-70
8	Disc spacer	1.4571 S4N	1.4571 S4N
9	Shaft bearing	1.4571 / PTFE	1.4571 / Ni-plated
10	Packing support ring	1.4571	1.4571
11	Packing set	PTFE	Graphite
12	Gland follower	1.4571	1.4571
13	Beville spring set	1.4568	1.4568
14	Packing gland	1.4408 / 1.4571	1.4408 / 1.4571
15	Antistatic spring	1.4310	1.4310
16	O-ring	FKM	FKM
17	Packing gland screw (hex socket cap screw)	A4-70	A4-70
18	Beville spring adjust- ment screw	1.4980	1.4980

* Bodies in carbon steel (1.0619/WCB) will be delivered with an anti-corrosive protection paint

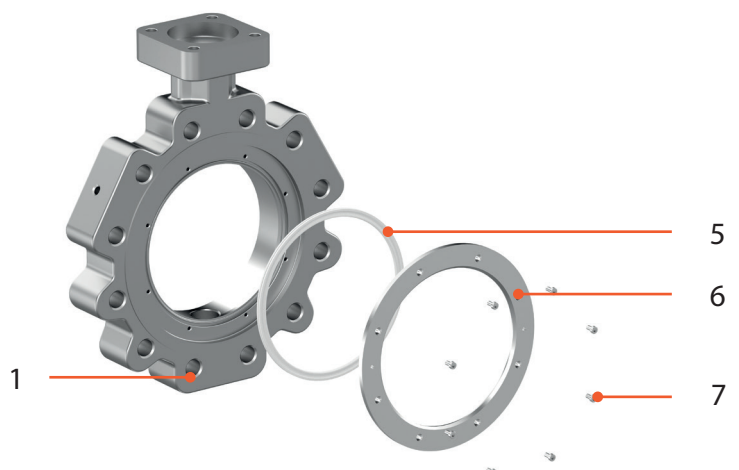

Series 800 ISO Repair Instructions

ATTENTION!

The disc (2), shaft (3), and taper pins (4) may only be used as a set (delivered or as previously disassembled).

Preparation:

1. Clean the valve body (1) of any debris, such as chips or burrs, and blow out all holes with compressed air.

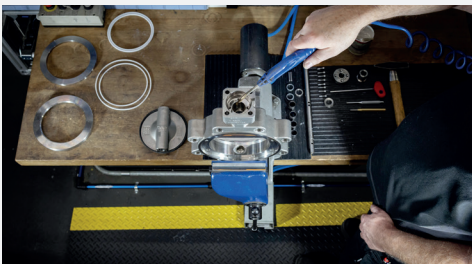

2. Remove the transport protection from the disc and remove the taper pins (4) and shaft (3) from the disc (2).

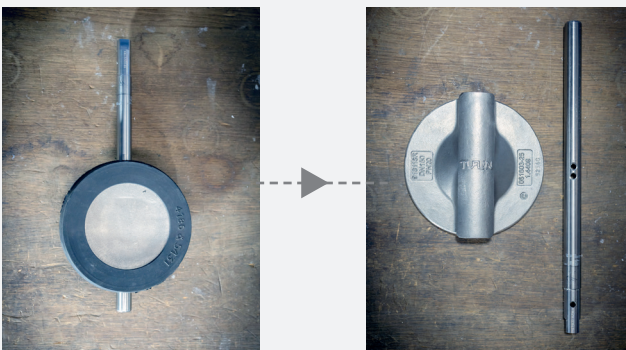

3. Affix the valve body (1), so that the body bore is vertical and the seat retaining ring side faces the assembler.

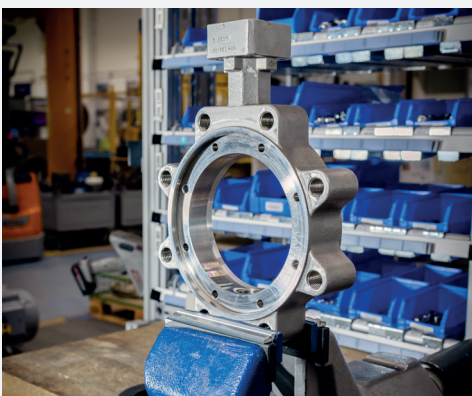

Preparation:

4. Insert the antistatic spring (15) into the packing gland (14).



5. Insert the O-ring (16) into the packing gland (14) above the spring.



6. Insert the shaft bearing (9) into the valve body (1). Bearing slots must be aligned transversely to the flow direction. If there is more than one shaft bearing ring, the slots must be offset by 180° each.

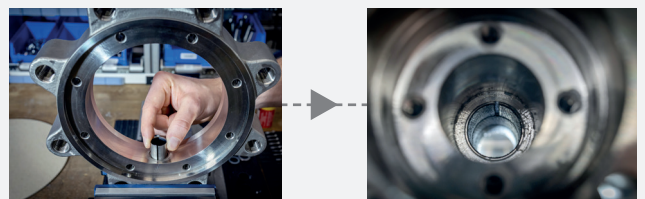

7. Insert the support ring (10) and align it against the lower support.



Series 800 ISO Repair Instructions

Shaft/Disc Assembly:

- Align the disc (2) and disc spacer rings (8) with the flat side towards the disc (2) and insert into the valve body (1).

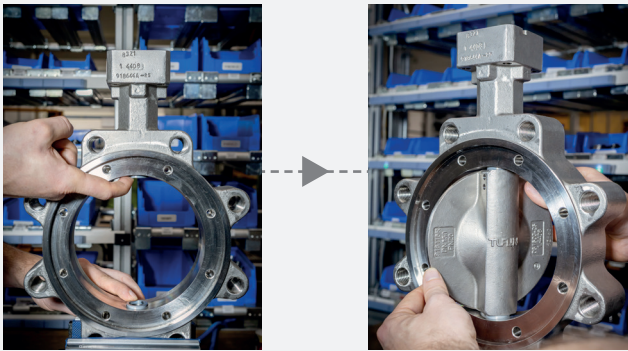

- Lightly grease the shaft (3) and insert it into the bore of the valve body (1), the disc (2), and disc spacer rings (8), aligning with the taper pin bores (note the taper direction!).

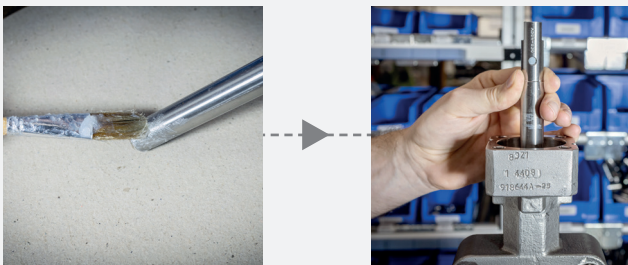

- Insert the taper pins (4); this must be possible over at least 2/3 of the length without force, otherwise check the position of the conical bores.



- Hammer in firmly and secure with a center punch.

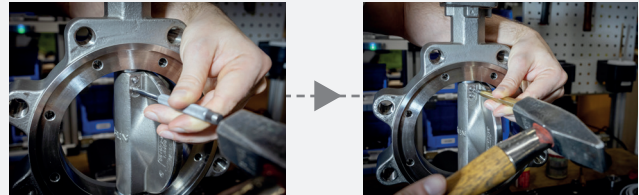

Series 800 ISO Repair Instructions

Packing Assembly:

12. Insert the new shaft packing (11) into the body bore.

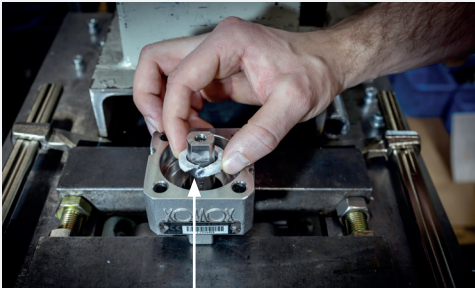

Make sure each ring's end cut at 45 degrees aligns properly without twisting the ring. Install the packing rings with an offset of approximately 120° to each other.

13. The new packing rings (11) must be installed individually. Each packing ring must be fully pressed into the housing with a defined force (**please reach out to XOMOX for required force**). For PTFE packings, three PTFE rings and one graphite ring are used. The sequence always starts with the PTFE rings and ends with the graphite ring.

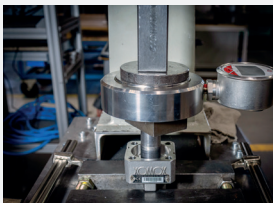

14. Install the new pressure ring (12).



15. Assemble the new beville springs (13) according to the drawing.

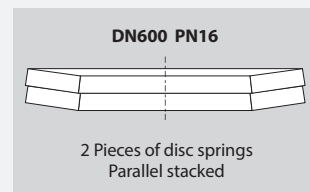
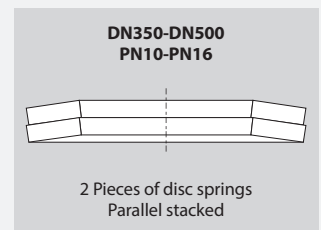
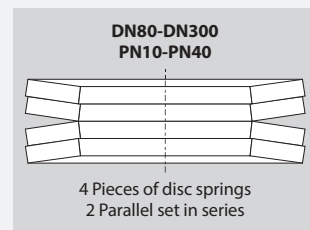
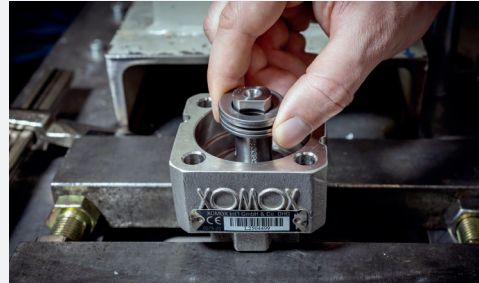

16. Assemble the packing gland (14) with a press to block, and tighten the new cylinder head screws (17) to the torque specified by XOMOX (**please reach out to XOMOX for actual values**).



Series 800 ISO Repair Instructions

17. The new adjusting screws (18) of the belleville springs must be tightened lightly (hand-tight) and must be flush with the top edge of the new packing gland (14).

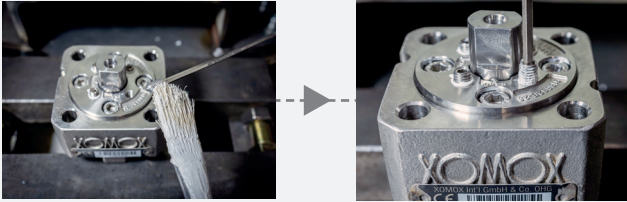

Seat Ring Assembly:

18. Clean the body groove before inserting the seat ring (5).

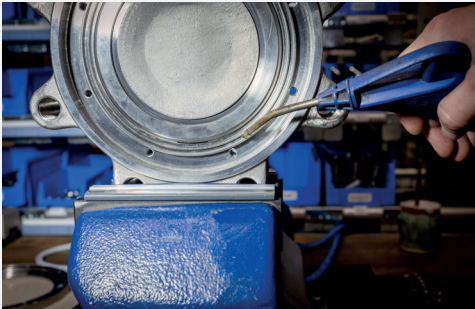

19. Bring the disc (2) to the closed position (0°).

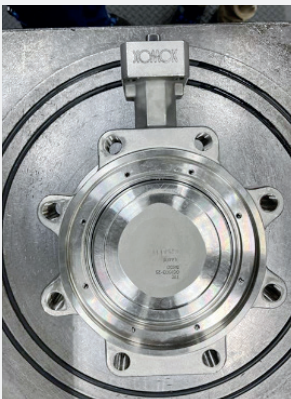

SNAP IN Seat Retainer Ring Assembly:

20. Insert the seat ring (5) into the body.

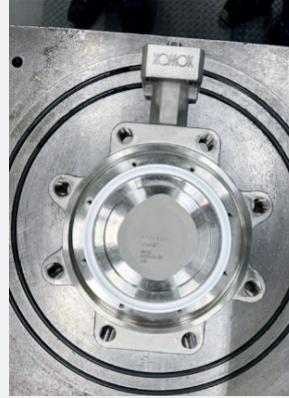

21. Place the seat retainer ring (6) with the flat side facing outwards and press it in. Maintain the pressing force.

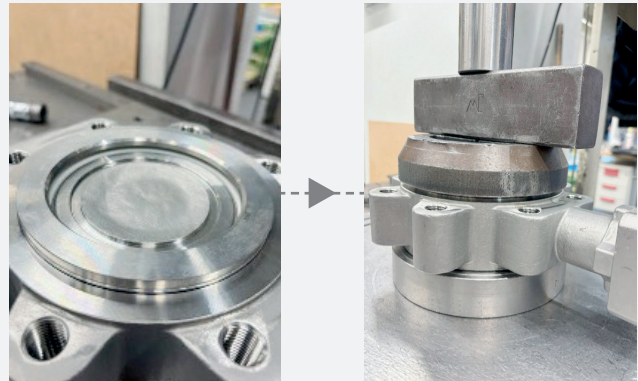

Series 800 ISO Repair Instructions

Screwed Seat Retainer Ring Assembly:

20. Insert the seat ring (5) into the body.

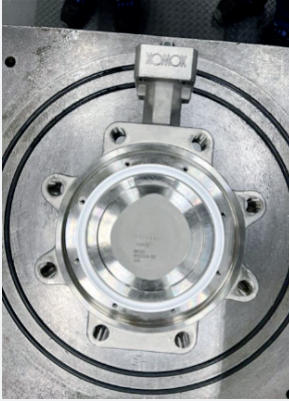

21. Place the seat retainer ring (6) with the flat side facing outwards and press it in. Maintain the pressing force while screwing in the screws to the torque specified by XOMOX (**please reach out to XOMOX for actual values**).

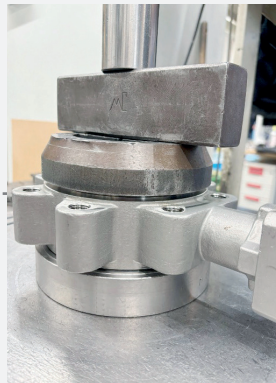
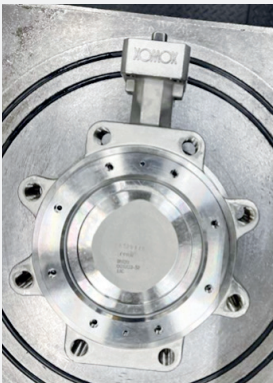

Screwed From the Back (-R) Seat Ring Assembly:

20. Apply grease to the seat retainer ring screws (7).



21. Insert the screws (7) in the respective bore holes.



21.1. Place the seat ring (5) and the large PTFE insert ring in the respective grooves of the seat retainer ring (6).



Series 800 ISO Repair Instructions

21.2. Position the assembled seat retainer ring (6) so that its holes align with the bore holes, then screw it in by hand until snug.

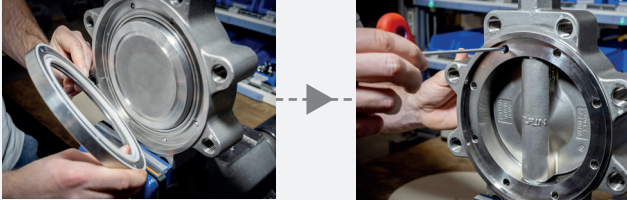

21.3. Place the seat retainer ring (6) with the flat side facing outward and press it in. Maintain the pressing force and tighten the screws until fully seated.

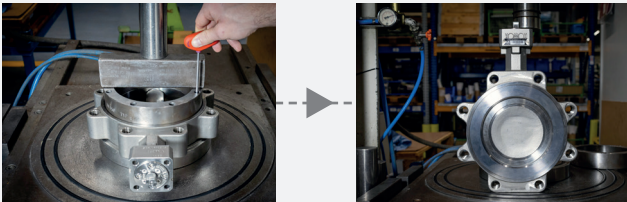

21.4. Fit the cover ring with the smaller PTFE insert ring, place it with the flat side facing outward, and press it in. Maintain the pressing force.

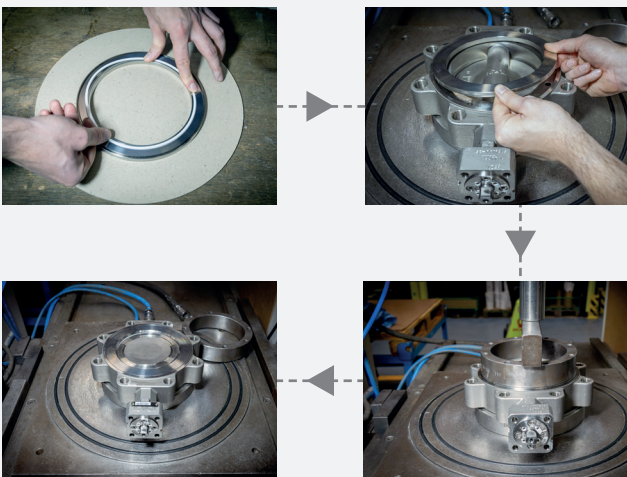

Testing:

22. Perform the tightness test with 6 bar air pressure, maintaining the pressing force on the seat retaining ring (6).



Series 800 ISO Troubleshooting

7. Help with Faults

With the remedying of faults the Section 2 <Safety notes> is absolutely to be adhered to

Type of the fault	Measurement	Note
Leakage at the flange connection/locking screw or body cover	Retighten flange-/locking screws. If the leakage cannot be remedied: Repair is necessary: Replace sealing: Spare parts and necessary instructions are to be requested from XOMOX.	
Leakage in the seat sealing	Check whether the valve is closed 100%. If 100% closed and an actuator is mounted: Check whether the actuator closes with full torque. If actuator ok: Open and close valve several times under pressure. If the gear is mounted, readjust final impact: Readjust the impact „CLOSE“ in the actuator in such a way that the butterfly valve disk can move somewhat further to the „CLOSE“-position. If valve is then still leaking: Repair is necessary: Replace seat sealing, spare parts and necessary instructions are to be requested from XOMOX	<u>Note 1:</u> Only original XOMOX®-spare parts may be installed. <u>Note 2:</u> If it is detected after the disassembly that the wetted inner parts are not sufficiently resistant towards the medium, parts of suitable material are to be selected
Leakage at the compression gland	⚠ Danger to Life Retighten both nuts at the gland alternately and in steps of ¼ rotation each. If the leakage can not be remedied by this: Repair is necessary: Spare parts and necessary instructions are to be requested from XOMOX. If the nuts at the gland have to be loosened or unscrewed: Observe section 2.3 <Special dangers>. To safeguard the operating staff against danger, ensure that the line is completely depressurized beforehand.	
Malfunction	Check actuator unit and control commands. Dismantle valve (observe thereby the notes of Section 2.3 <Special dangers>) and inspect. If the valve is damaged: Repair is necessary: Spare parts and necessary instructions are to be requested from XOMOX.	

With faults at the actuator unit, see appropriate instructions.

CRANE®

CRANE CHEMPHARMA & ENERGY

Xomox International GmbH & Co.OHG
Von-Behring-Straße 15
88131 Lindau (Bodensee)
Germany
Tel.: +49 8382 702-0

Xomox Corp.
4444 Cooper Road,
Cincinnati, OH 45242
USA
Tel.: (513) 745-6000

Crane Company, and its subsidiaries cannot accept responsibility for possible errors in catalogues, brochures, other printed materials, and website information. Crane Company reserves the right to alter its products without notice, including products already on order provided that such alteration can be made without changes being necessary in specifications already agreed. All trademarks in this material are the property of the Crane Company or its subsidiaries. The Crane and Crane brands logotype (ALOYCO®, BAUM®, CENTER LINE®, CRANE®, CRYOWORKS®, DEPA® & ELRO®, DOPAK®, DUO-CHEK®, FLOWSEAL®, GYROLOK®, GO REGULATOR®, HOKE®, JENKINS®, KROMBACH®, NOZ-CHEK®, PACIFIC®, RESISTOFLEX®, XOMOX®, SAUNDERS®, STOCKHAM®, TECHNIFAB®, TEXAS SAMPLING®, WESTLOCK CONTROLS®, WTA®, and XOMOX®) are registered trademarks of Crane Company. All rights reserved.
