

XOMOX®

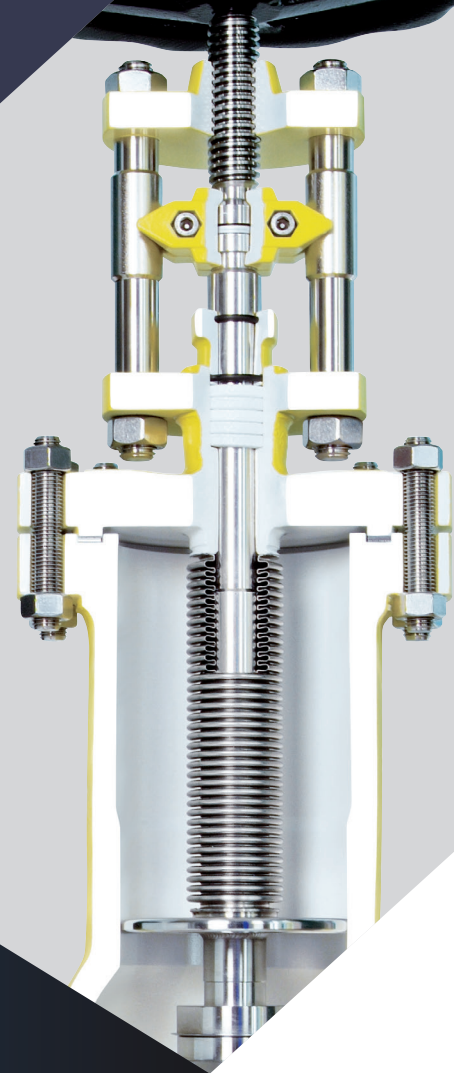

WTA® CHLORVENTILE

Bellows Sealed Globe Valves provide the highest fugitive emission protection for use in Chlor-Alkali applications.

KEY FEATURES INCLUDE

- 1 **SUPERIOR SAFETY SEALING SYSTEM** with multiple walled bellows, gland packing, metal back seat, two-part rising stem, stellite coated, conical shaped piston and seat.
- 2 Compliant with the demanding **EURO CHLOR AND CHLORINE INSTITUTE** Specifications for Bellows Sealed
- 3 Globe Valves used for Chlor-Alkali applications. Manufactured and tested in an ISO compliant clean room with ultrasonic cleaning system to ensure safety, quality, and **GAS-LEAK TIGHTNESS**.



CRANE



www.cranecpe.com

WTA® Chlorine Valves

Product Features

- Bonnet flange in tongue and groove design; stud bolted, with a nut at each end; bonnet gasket coated with PTFE.
- Bellows anti-torque device with integrated position indicator (for open and closed positions)
- Safety gland packing made of PTFE-silk; gland follower with double O-ring seal to prevent ingress of medium into the packing area.
- Protected multiple-wall bellows made of 2.4819/Hastelloy® C276, designed for 10,000 cycles, installed beyond main flow area.
- Disc with conical plug, sealing surface hardened with Stellite® 6, seat hardened with Stellite® 21.

Typical Applications

Processing systems handling liquid chlorine or dry chlorine gas, and similar hazardous media.

Temperature Range

Standard	Unit	Temp. Carbon Steel	
Euro Chlor	°C	Tmin	-40
		Tmax	+120
GEST	°F	Tmin	-40
		Tmax	+248

Other temperature ranges are available without Euro Chlor Certificate.

Special Options

- Pneumatically actuated according to GEST
- Complete internals in 2.4819/Hastelloy® C276 available on request

Compliance

- Chlorine Institute Pamphlet 6 and Euro Chlor GEST specification

Hastelloy® is a trademark of Haynes International Inc.
Stellite® is a registered trademark of Deloro Stellite.

Size Range

DN 25, 40, 50, 80, 100, 150 / NPS 1", 1 ½", 2", 3", 4", 6"
Other sizes are available on request

Pressure Rates

PN 40 and Class 300
Other classes are available on request

Materials of Construction

Low temperature Carbon Steel 1.6220 / LCB / LCC
Other sizes are available on request

Body Configurations

Straight type

End Connections

Flange design in accordance with EN 1092-1 and ASME B 16.5.

Post-Manufacture Handling and Final Tests

- Drying at a temperature of 120°C (248°F) for at least 3 hours
- Introduction of drying agents (Silica gel) into the valve
- Blanking of inlet and outlet orifices with suitable gaskets and bolted flanges to avoid entry of moisture into the valve
- Unfinished surfaces protected against rust
- Lubricated with chlorofluorinated grease

Testing/Marking

- Tests and design per Euro Chlor GEST recommendation and Chlorine Institute Pamphlet 6
- Quality level 3 of ASTM E446 or equivalent standard for body and bonnet
- TÜV type test approval to VdTÜV 1065 available
- Standard tests to DIN EN 12266 Part 1, shell and leak test acc. to item P10/P11/P12 (leakage rate A)