

VACUUM JACKETED PIPING SOLUTIONS

www.cranecpe.com

brands you trust.

REDUCED HEAT LEAK. INCREASED FLOW RATE.

CRANE® cryogenic vacuum jacketed piping is the optimal solution for transporting cryogenic liquids with minimal waste, maximum flexibility, and speedy delivery.

CRANE ChemPharma & Energy

Table Of **CONTENTS**

04-08	About Crane ChemPharma & Energy
09-11	About Crane® Cyogenic Products
12	Introducing VJP Solutions
13-18	Crane® VJ Rigid & Bendable Piping
19-24	Crane® VJ Transfer Hose
25-31	Crane® VJ Manifolds
32	Index: Unit conversion
33	Index: Notes

CRANE

®



Crane ChemPharma & Energy **INTRODUCTION**

Crane Co. is a diversified manufacturer of highly engineered industrial products with a substantial presence in a number of focused niche markets. We are dedicated to integrity and honest dealings in all that we do.

Crane CP&E designs and manufactures a variety of high performance products including: highly-engineered check valves, sleeved plug valves, lined valves, process ball valves, high performance butterfly valves, bellows sealed globe valves, aseptic and industrial diaphragm valves, multi/quarter-turn valves, actuation, sight glasses, lined pipe, fitting and hoses, and air-operated diaphragm and peristaltic pumps. Its trusted brands are in use worldwide in many industries, including Oil & Gas, Oil Refining, Petrochemical, Power Generation, Chemical Processing, Biotechnology, and Pharmaceutical.

Crane CP&E WORLDWIDE

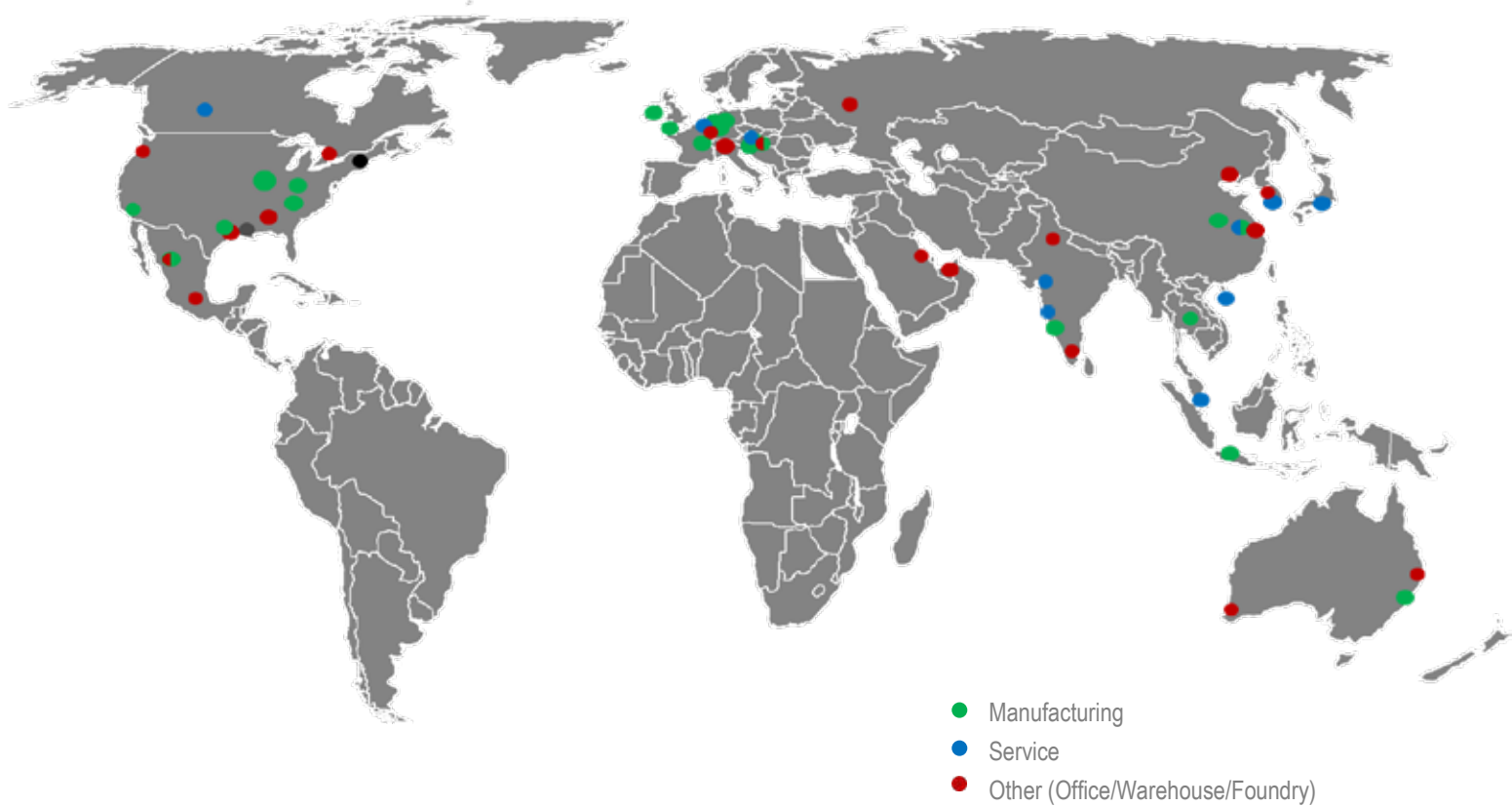

CPE MANUFACTURING SITES (Examples):



AMERICAS

CHIHUAHUA, MEX • CINCINNATI, OH
• CULLMAN, AL • EDMONTON, AB
• GONZALES, LA • HOUSTON, TX
• MARION, NC MEXICO CITY, MEX
• PORTLAND, OR • SADDLE
BROOK, NJ • SPARTANBURG,
SC • CONROE, TX , HQ: THE
WOODLANDS (HOUSTON), TX



EUROPE

BELFAST, UK • CWMBRAN, UK,
CRONING , SL • DÜSSELDORF, DE
• KREUZTAL, DE • LINDAU, DE •
SZÉKESVERHÉRVÁR, HU MUTA, SL
• MAXDORF, DE • MONZA, IT • MUL-
HOUSE, FR • BERGSCHENHOEK,
NL WAALWIJK, NL • WAVRE, BE •
WR. NEUDORF, AT



ASIA

BEIJING, PRC • CHENNAI (MA-
DRAS), INDIA KANAGAWA, JAPAN •
NINJIN, PRC • PUNE, INDIA SATARA,
INDIA • SHANGHAI, PRC SINGA-
PORE • SUZHOU, PRC • VIRALI-
MALAI, INDIA

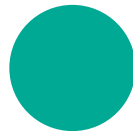

AUSTRALIA

BRISBANE • KEWDALE • MEL-
BOURNE • ST. MARYS



MIDDLE EAST

AL KHOBAR, SAUDI ARABIA • DUBAI,
UAE

Process Flow Technologies

VALVE GROUP

BRANDS YOU TRUST

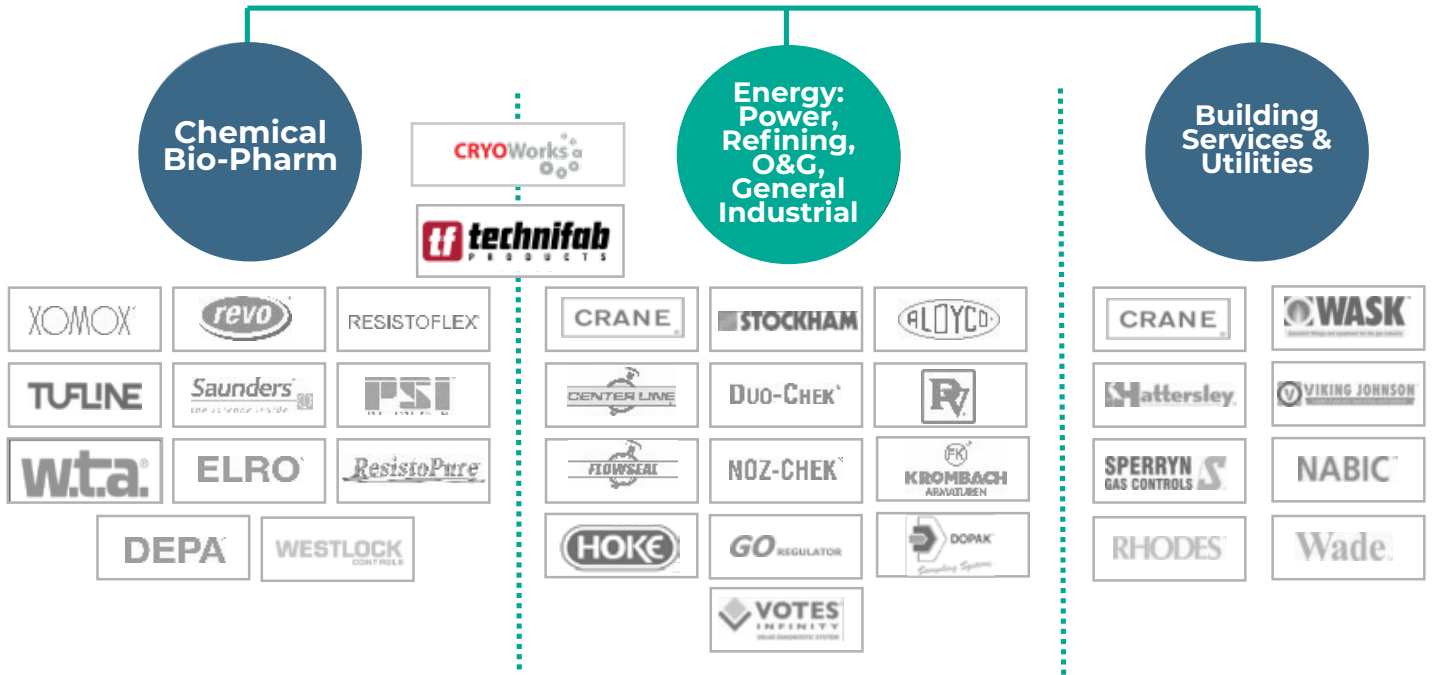



Local **SERVICE**

CRANE is committed to delivering efficient service and local technical expertise.

Crane is built on quality principles and practices to achieve the best safety, quality, performance, delivery, service and total cost.

Our vision as a global provider is to be the Supplier of Choice for on/off process valve solutions in chemical, power and refining, known for best-in-class customer responsiveness.



Quick access to high-demand stock



Engineering support



System design and drawings



MRO services



Training and testing



ABOUT CRANE CRYOGENIC PRODUCTS

For hydrogen energy to be an effective and efficient alternative to fossil fuels, liquefaction plants, storage facilities, transportation methods and pipelines must be outfitted with state-of-the-art PVF (Pipe Valves and Fittings) components. Crane® cryogenic products is focused on solving Customer's toughest challenges within the Hydrogen Industry backed by decades of field experience in severe service applications.

Crane® Cryogenic Product Solutions for Cryogenic Applications:

- Production
- Liquefaction
- Transportation
- Transfer
- Storage

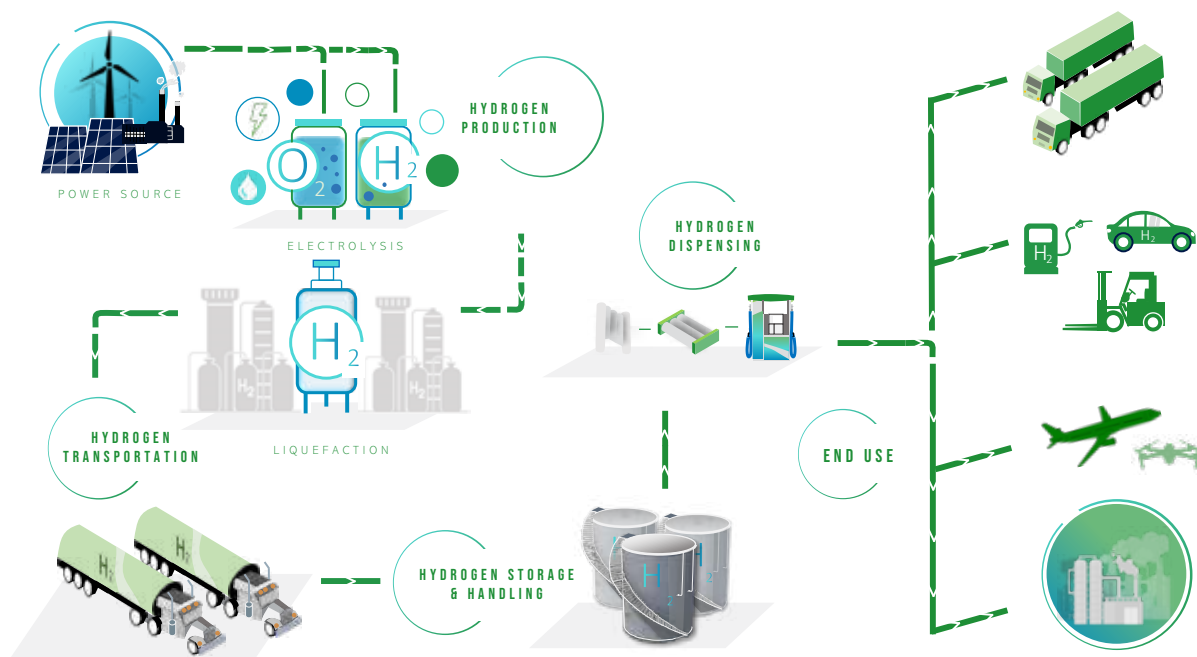

CRYOGENICS VS UNIVERSAL COSMIC COLD

How cryogenic fluids compare to low temperatures across the universe

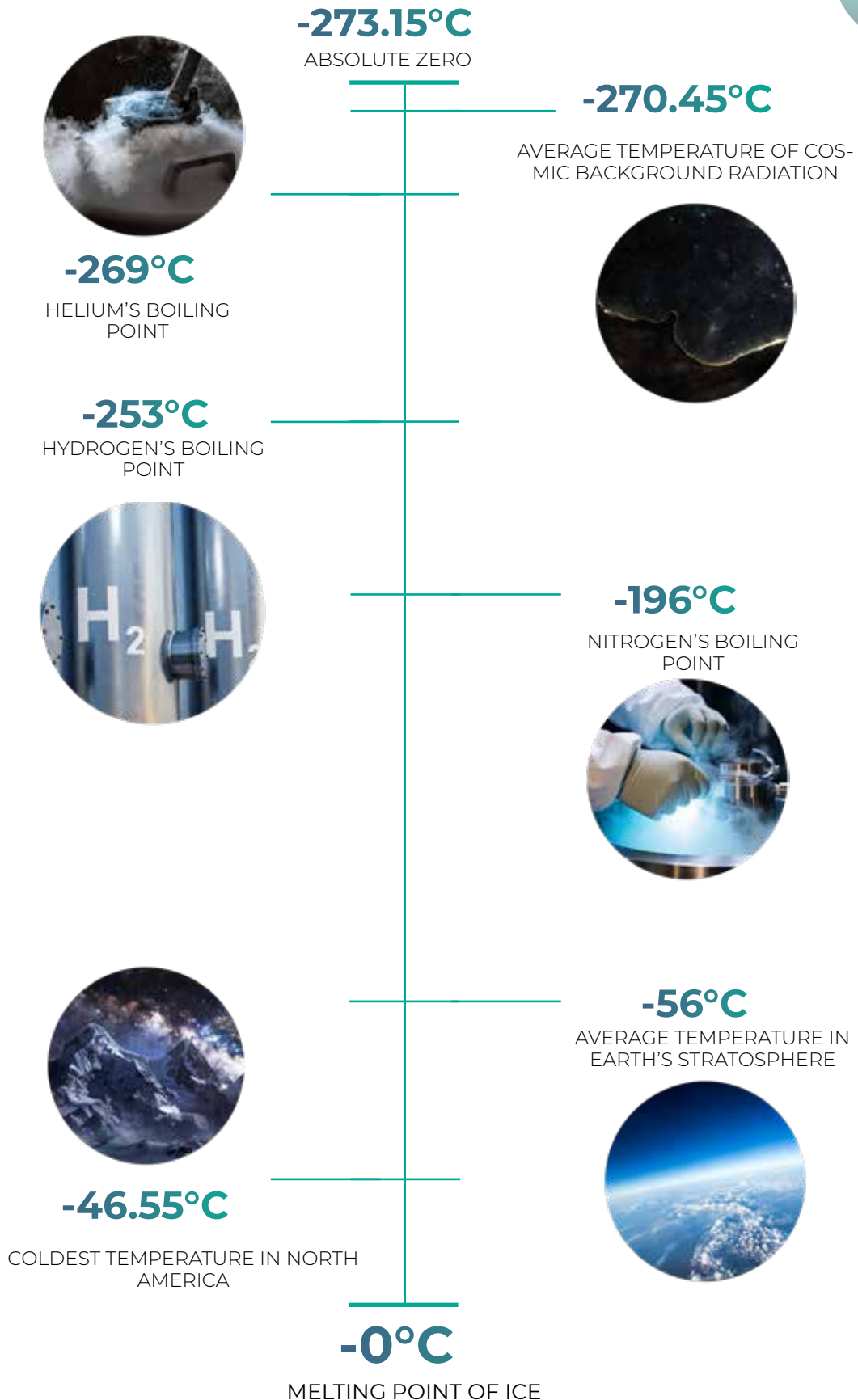



Our New Conroe Facility

ISO 9001:2015 Certified Facility for Design, manufacturing and testing of Vacuum Jacketed Piping products & valves for cryogenic applications

Profile

- 80,000 Sq-ft
- Planned 90 Associates
- 1 Hour to downtown Houston

Core Technology

- Cryogenic Applications
- Vacuum Acquisition
- Welding/Fabrication
- Valve Automation

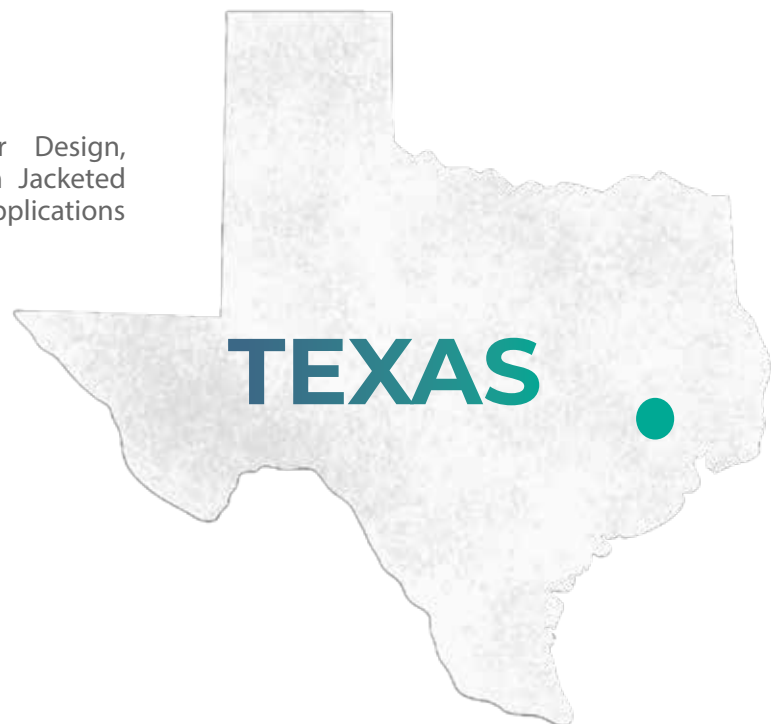

INTRODUCING VACUUM JACKETED PIPING SOLUTIONS

Crane® offers a distinguished product lineup of vacuum-jacketed piping solutions designed for cryogenic applications, delivering specialized and efficient solutions for the industry.



VJ Rigid & Bendable Piping

Crane® cryogenic Vacuum jacketed rigid & bendable piping is a double-walled pipe that uses a vacuum to reduce heat transfer and prevent product boil-off. It is used to transfer cryogenic liquids, such as hydrogen, nitrogen, and oxygen.



VJ Transfer Hose

Crane® cryogenic Vacuum jacketed transfer hose is a type of vacuum insulated pipe with a flexible outer jacket. It is used in process plant installations to transfer cryogenic liquids from a bulk storage vessel to use points.

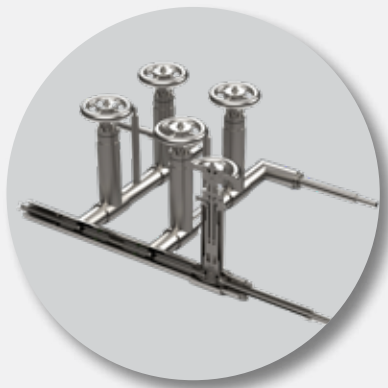

VJ Manifold

Crane® cryogenic manifolds are tailor-made for cryogenic liquid transfer with high-quality components, enhanced flow and heat control, and user-friendly connections that support all storage tank and trailer layouts.

CRANE® VJ Rigid & Bendable Piping

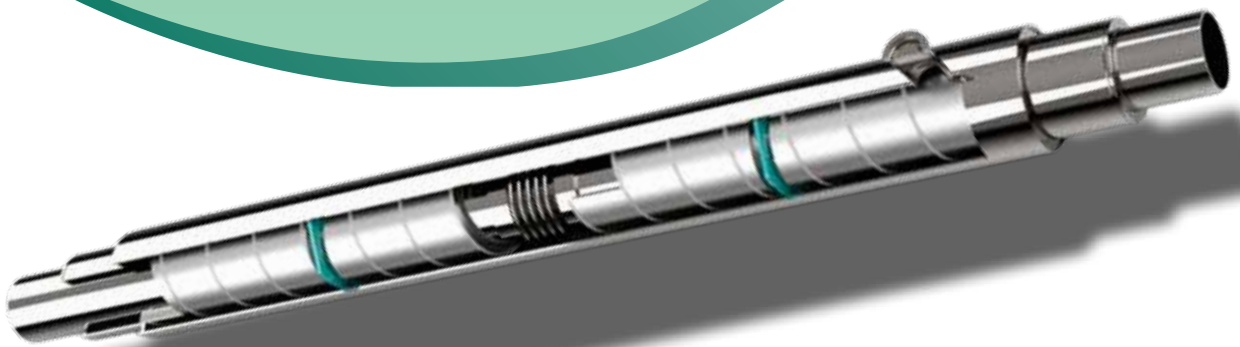

ABOUT OUR VJ RIGID & BENDABLE PIPING

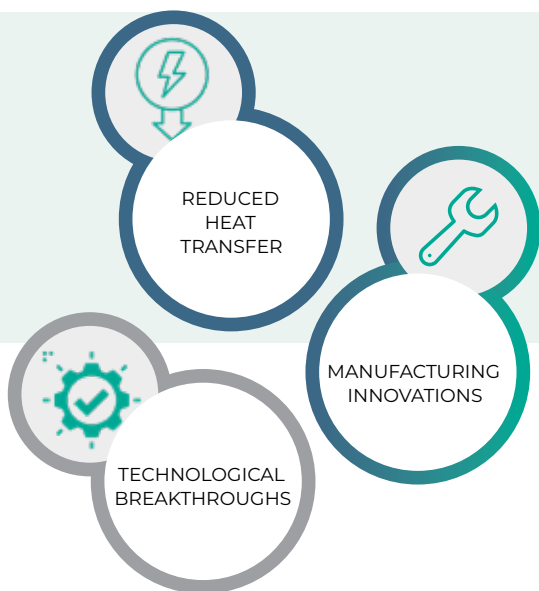

Crane® is pleased to announce the launch of its new vacuum jacketed piping (VJP) product line. VJP is a double-walled piping system with a vacuum space between the inner and outer pipes. This vacuum space acts as a thermal barrier that reduces heat transfer and prevents product boil-off, minimizing product loss and ensuring safety and quality. Additional insulation is also present to further enhance thermal performance.

Vacuum Jacketed Piping OVERVIEW

VJP is ideal for transporting liquid cryogenic media, which are substances that exist in a liquid state at very low temperatures, such as liquid nitrogen, oxygen, argon, hydrogen, helium, or carbon dioxide. Cryogenic fluids are used in a wide range of applications, including aerospace, medical, industrial, and energy.

Benefits of Crane® Vacuum Jacketed Piping

Crane® VJP offers a number of significant advantages over conventional piping systems for liquid cryogenic media, including:

Reduced heat transfer and product boil-off: VJP significantly reduces heat transfer and product boil-off, leading to cost savings and improved efficiency.

Enhanced safety and reliability: VJP is designed to meet the highest safety standards, with the vacuum space and insulation helping to prevent leaks and spills. The system is also resistant to corrosion and other environmental factors.

Easy installation, operation, and maintenance: VJP is easy to install, operate, and maintain, with a modular design that can be customized to fit any application.

1-year warranty: Crane® VJP comes with a 1-year warranty, demonstrating our confidence in the quality and reliability of our product.



Reduced Heat Transfer

Minimize product loss



Manufacturing Innovations

Unmatched quality and manufacturing agility



Technological Breakthroughs

Delivering best-in-class quote time





KEY FEATURES

Size Range

- Inner Pipe Size: 1/2", 1", 1-1/2", 2", 3", and 4" NPS

Pressure Ratings

- Up to 150 PSIG

Materials of Construction

- 300 Series Stainless Steel

Design Standards and Compliance

- ASME B31.12: Hydrogen Piping & Pipeline
- ASME B31.3: Process Piping
- CGA G-4.15: Vacuum-Jacketed Piping in Liquid Oxygen Service
- CGA G-5.6 – Hydrogen Pipeline Systems
- AWS 2.4 Standard symbols for welding, brazing and non-destructive examination
- AWS B2.1, ISO 15607, EN 1011-1: Specification for welding procedure and performance qualification
- AWS D10.18 Pipe welding (stainless steel)
- ASME B16.5: Pipe Flanges and Flanged Fittings
- ASME B16.9 – Factory made Wrought & fabricated butt welding fittings
- ASME B36.19M : Stainless Steel Pipe
- ASME BPVC Section IX: Welding and Brazing Qualifications

End Connections

- Bayonet
- Field Joint
- Mechanical Fitting

Testing Standard

- ASME B31.12: Hydrogen Piping & Pipeline
- ASME B31.3: Process Piping
- AWS B1.10 & ISO 17035: Guide for nondestructive examination of welds
- ASME BPVC Section V – Nondestructive Examination

KEY COMPONENTS

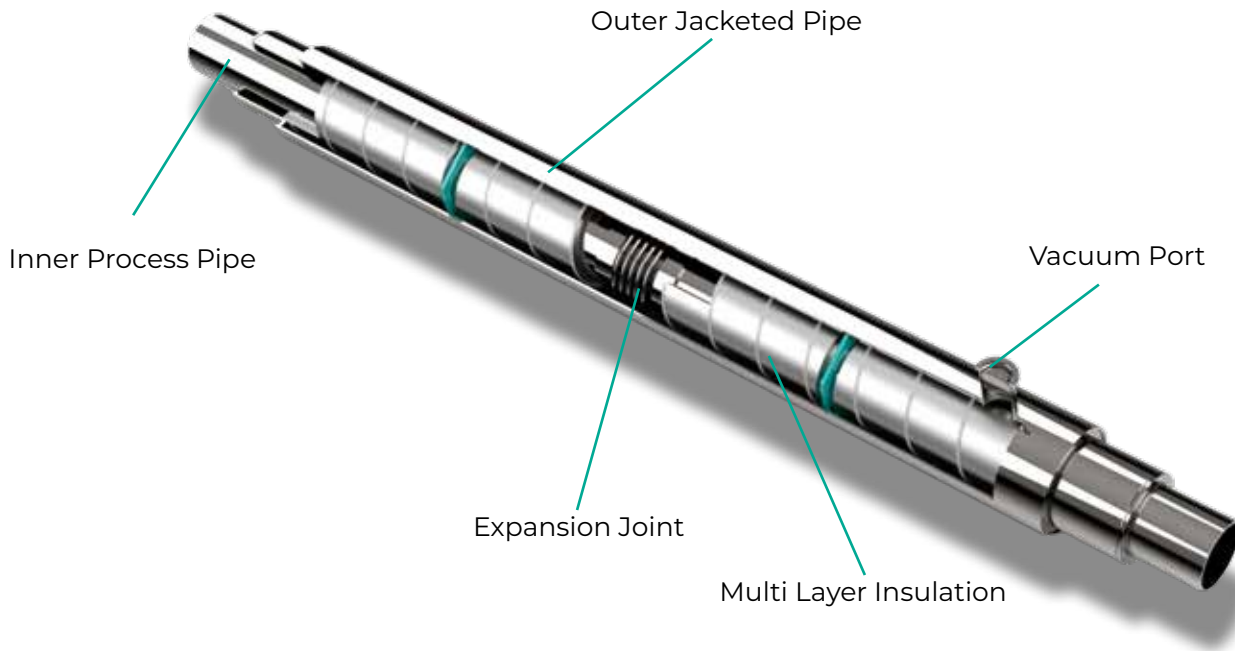
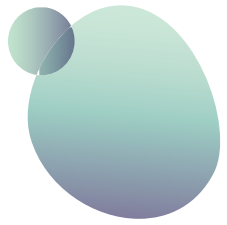

Inner process pipe: This is the innermost pipe that transports the cryogenic liquid from the source to the destination. It is usually made of stainless steel or copper and has a small diameter to reduce the surface area exposed to heat.

Outer jacketed piping: This is the outermost pipe that surrounds the inner pipe and forms the vacuum jacket. It is also made of stainless steel and has a larger diameter than the inner pipe. It is welded at both ends to seal the vacuum and prevent air from entering the system.

Vacuum port: This is a valve that is attached to the outer pipe and allows the air to be evacuated from the space between the inner and outer pipes. It creates a low-pressure environment that reduces the heat transfer by conduction and convection.

Expansion joint: Expansion Joints compensate for the thermal contraction of the inner-line preventing thermal stress

MLI Layer Insulation: MLI is alternating layers of reflective material and low thermal conductivity material. The reflective material reduces radiation (or radiative heat transfer) and the conductive resistance material reduces conduction (or conductive heat transfer).

PRODUCT APPLICATIONS

Crane cryogenic vacuum jacketed flexible piping is a versatile and reliable solution for a variety of applications, including:



Food Processing

Cryogenic liquids are used to quickly cool and freeze food products with VJP, which helps to maintain their freshness and quality. VJP connects cryogenic liquids to freezers, chillers, and cryogenic grinders that process food items.



Pharmaceutical Manufacturing

Cryogenic liquids are used to support various pharmaceutical manufacturing processes with VJP, such as the production of vaccines and antibiotics. VJP connects cryogenic liquids to bioreactors and freeze dryers that manufacture pharmaceutical products.



Electronics Manufacturing

Cryogenic liquids are used to regulate the temperature of electronic devices during manufacturing with VJP, which helps to ensure their quality and performance. VJP connects cryogenic liquids to semiconductor etching and doping machines that produce electronic devices.



Research and Development

Cryogenic liquids are used to create ultracold environments and to cool superconducting magnets with VJP, which enable the study of quantum phenomena and other experiments. VJP connects cryogenic liquids to research and development facilities that conduct scientific investigations.



CRANE® VJ Transfer Hose

ABOUT OUR VJ TRANSFER HOSE



Crane® Vacuum Jacketed Transfer Hose is the gold standard for cryogenic applications. It is made of two stainless steel pipes, with the inner pipe carrying the cryogenic liquid and the outer pipe providing vacuum insulation.

Vacuum Jacketed Flexible Piping OVERVIEW

The vacuum insulation minimizes heat transfer, which helps to keep the cryogenic liquid cold and prevents it from evaporating. Vacuum jacketed transfer hose is also very flexible, making it easy to install and maneuver in tight spaces. It is also resistant to corrosion and chemicals, making it a durable and long-lasting solution for cryogenics applications.

If you are looking for a safe, efficient, and cost-effective way to produce, store, and transfer cryogenic liquids, then CRANE® vacuum jacketed transfer hose is the best solution for you.

We have stocking sizes available with same-day shipment available.



Reduced Heat Leak

Minimize product loss and ice buildup vs standard hoses



Flexible and Durable

Easy to install and maneuver in tight spaces



Fast Product Availability

Stocking standard sizes with same day shipments available





KEY FEATURES

Size Range

- Inner Hose Size: ¼", 3/8", ½", 1"

Pressure Ratings

- 150 PSIG for Cryogenic

Materials of Construction

- 300 Series Stainless Steel

Design Standards and Compliance

- Built in accordance with ASME B31.3: Process Piping
- ISO 9001:2015 based Quality system

Temperature Range

- Designed for -321°F to 120°F

End Connections

- Plain End
- Flare Nuts
- Pipe Thread

Design Features

- Covered: Armored or Braided optional
- Temperature Control: Maintains ambient temperature on OD of Hose and reduces boil off of the cryogenic media.
- Safety: Minimizes opportunities for cryoburns or ice-build up to reduce potential for slips & falls
- Static Vacuum – State of the art vacuum acquisition process
- Flexible: Allows movement and stays flexible during fluid transfer.

KEY COMPONENTS

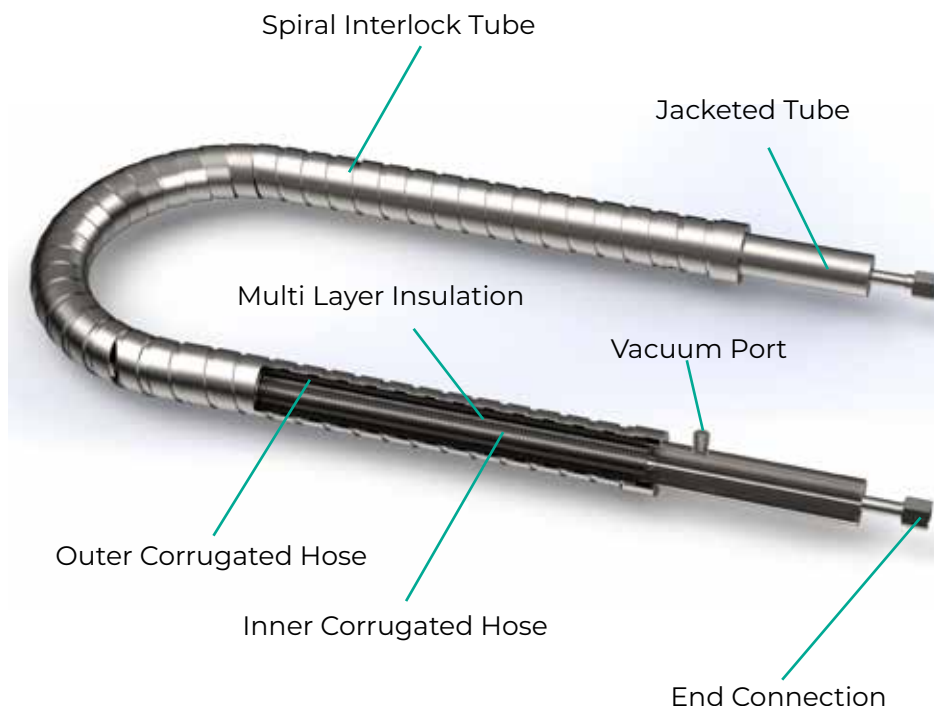
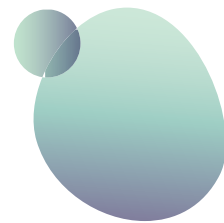

Inner Corrugated Hose: This is the core of the piping system, where the cryogenic liquid flows. It is made of stainless steel. The hose has a corrugated shape that allows it to bend and stretch without breaking or leaking.

Multilayer Insulation: This is the layer that surrounds the inner hose and prevents heat transfer from the environment. It is composed of multiple layers of reflective material that reflect infrared radiation and reduce heat loss. The insulation is wrapped in a spiral pattern around the inner hose to create an even distribution of thermal resistance.

Jacketed Tube: This is a thin-walled tube that covers the multilayer insulation and provides additional support for the inner hose. It also helps to create a vacuum in the space between the inner and outer hoses, which further reduces heat transfer.

Spiral Interlock Tube: This is a flexible metal tube that coils around the jacketed tube and protects it from physical damage. It also helps to maintain the vacuum in the annular space by preventing air leakage.

Outer Corrugated Hose: This is the outermost layer of the piping system, which protects the inner layers from external factors such as weather, corrosion, and abrasion. It is also made of stainless steel and has a corrugated shape that gives it flexibility and strength.

Vacuum Port: This is a small opening in the outer hose that is used to evacuate the air from the annular space and create a vacuum. The vacuum port is usually sealed with a vacuum valve to preserve the vacuum level.

End Connections: Our product can be customized with different types of end connections to suit various applications. Some of the common end connections are bayonet fittings, which allow for quick and easy connection and disconnection of the piping system.

PRODUCT APPLICATIONS

Crane cryogenic vacuum jacketed transfer hose is a versatile and reliable solution for a variety of applications, including:



Liquid Cylinder Filling

This piping can connect a liquid cylinder to a cryogenic storage tank or a dewar, allowing for safe and efficient filling of liquid nitrogen, liquid oxygen, liquid argon, or other cryogenic liquids. The hose prevents heat loss and pressure buildup during the filling process, ensuring that the liquid is transferred quickly and efficiently without any loss of product.



Dewars and Cold Plates

This piping can also connect a dewar or a cold plate to a cryogenic source, providing a constant supply of cold gas or liquid for cooling purposes. The hose maintains the desired temperature and flow rate of the cryogen, as well as prevents condensation and frost formation on the equipment. This is essential for maintaining the performance of sensitive equipment and ensuring the safety of personnel.



Cryo-storage Freezers and Laboratories

This piping can also be used to supply cryogenic liquids or gases to freezers or laboratories that store or handle biological samples, such as blood, DNA, RNA, or tissues. The hose ensures the optimal preservation and viability of the samples, as well as protects the personnel and the environment from exposure to hazardous or infectious materials.



Equipment Connections

This piping can also be used to connect various equipment that requires cryogenic or high-temperature fluids, such as valves, pumps, regulators, meters, or sensors. The hose provides flexibility and durability for the equipment, as well as reduces maintenance and operational costs.

HOW TO ORDER

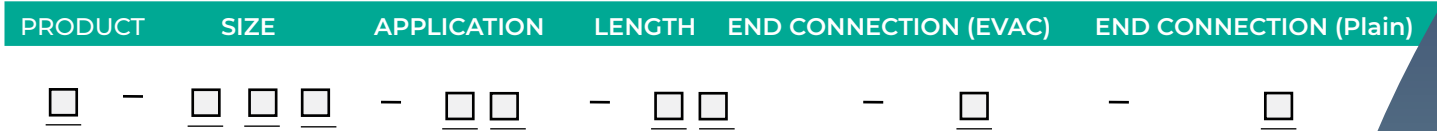

* ORDER EXAMPLE AVAILABLE BELOW

PRODUCT	
F	Vacuum Jacketed Flexible Pipe

SIZE	
004	1/4" Flex
006	3/8" Flex
008	1/2" Flex
016	1" Flex

APPLICATION	
N2	Nitrogen
AR	Argon
NG	Natural Gas
O2	Oxygen

LENGTH	
04	4 ft
06	6 ft
08	8 ft
10	10 ft
12	12 ft
20	20 ft

END CONNECTION (EVAC)	
A	CGA-295 Female Flare
B	MNPT
C	Plain Tube End

END CONNECTION (Plain)	
A	CGA-295 Female Flare
B	MNPT
C	Plain Tube End

ORDER EXAMPLE: F-008-N2-10-C-C

1/2" size VJ Transfer Hose of 10ft length with Plain Tube EVAC and plain end connections for Nitrogen Applications

CRANE® VJ Manifolds



ABOUT OUR VJ MANIFOLDS



Crane® provides fully customizable manifolds that support all storage tank and trailer layouts. These manifolds consist of high-quality valves, fittings, and hoses that are designed to optimize flow rates and minimize heat transfer. The manifolds use the improved CV Bellows Seal Globe Valve, which offers excellent sealing and durability for cryogenic applications. The manifolds also have improved product connections, such as quick disconnects and bayonet couplings, that allow for easy and safe operation.



Performance

Innovative engineered design greatly reduces Hydrogen loss through improved heat transfer and enhanced CV.



Lead Time

Automated facility delivers products faster and more efficiently with consistent quality.



Bespoke Solutions

CRANE® offers full customization and engineering for any tank layout.

A SOLUTION FOR EFFICIENT STORAGE TANK FILLING AND WITHDRAWAL

Storage tanks are essential for storing and transporting cryogenic fluids, such as liquid nitrogen, oxygen, and hydrogen. However, filling and withdrawing these fluids from the tanks can be challenging, as they require extremely low temperatures and high pressures to maintain their liquid state. Any heat transfer from the ambient environment can cause vaporization and pressure build-up, resulting in product loss and safety hazards. Thermal performance and the Flow Coefficient are two of the most critical aspects to consider when designing high-efficiency cryogenic valves. Utilizing CFD simulations & analysis integral to the design and development of new products, Crane® is pushing boundaries in Hydrogen.

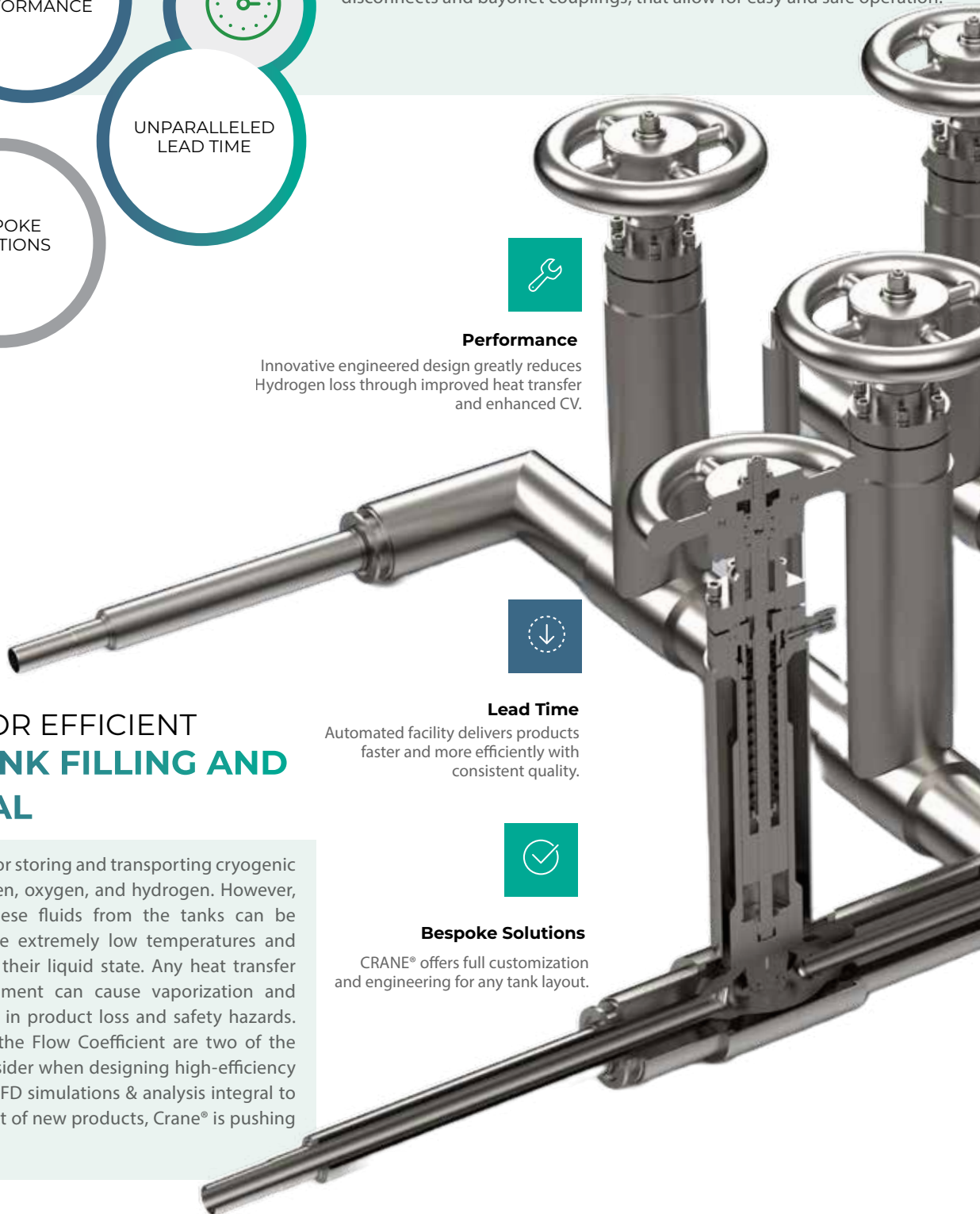

KEY FEATURES

Size Range

Inner Pipe Size: 1/2", 1", 1-1/2", 2", 3", and 4" NPS

Pressure Ratings

- 300 PSIG for Cryogenic

Materials of Construction

- 300 Series Stainless Steel

Design Standards and Compliance

- Built in accordance with ASME B31.3: Process Piping
- ASME B31.12: Hydrogen Piping & Pipeline
- CGA G-4.15: Vacuum-Jacketed Piping in Liquid Oxygen Service
- CGA G-5.6 – Hydrogen Pipeline Systems
- ASME B36.19M : Stainless Steel Pipe
- ASME BPVC Section IX: Welding and Brazing Qualifications
- NFPA 2 – Hydrogen Technologies Code
- AWS B1.10 & ISO 17035: Guide for nondestructive examination of welds
- ASME BPVC Section V – Nondestructive Examination

End Connections

- Bayonet
- Field Joint
- Mechanical Fitting

Design Features

- Fugitive Emission: Helium mass spec to 1×10^{-9} cm³/s
- Outgassing Getter, Molecular Sieve & Multi-Layer Insulation for Static Vacuum
- ASME B31.3 Certification
- Pressure Drop, Heat Leak, and Thermal Contraction of the System
- Internal G-10 Supports and Outer Pipe Supports



KEY COMPONENTS

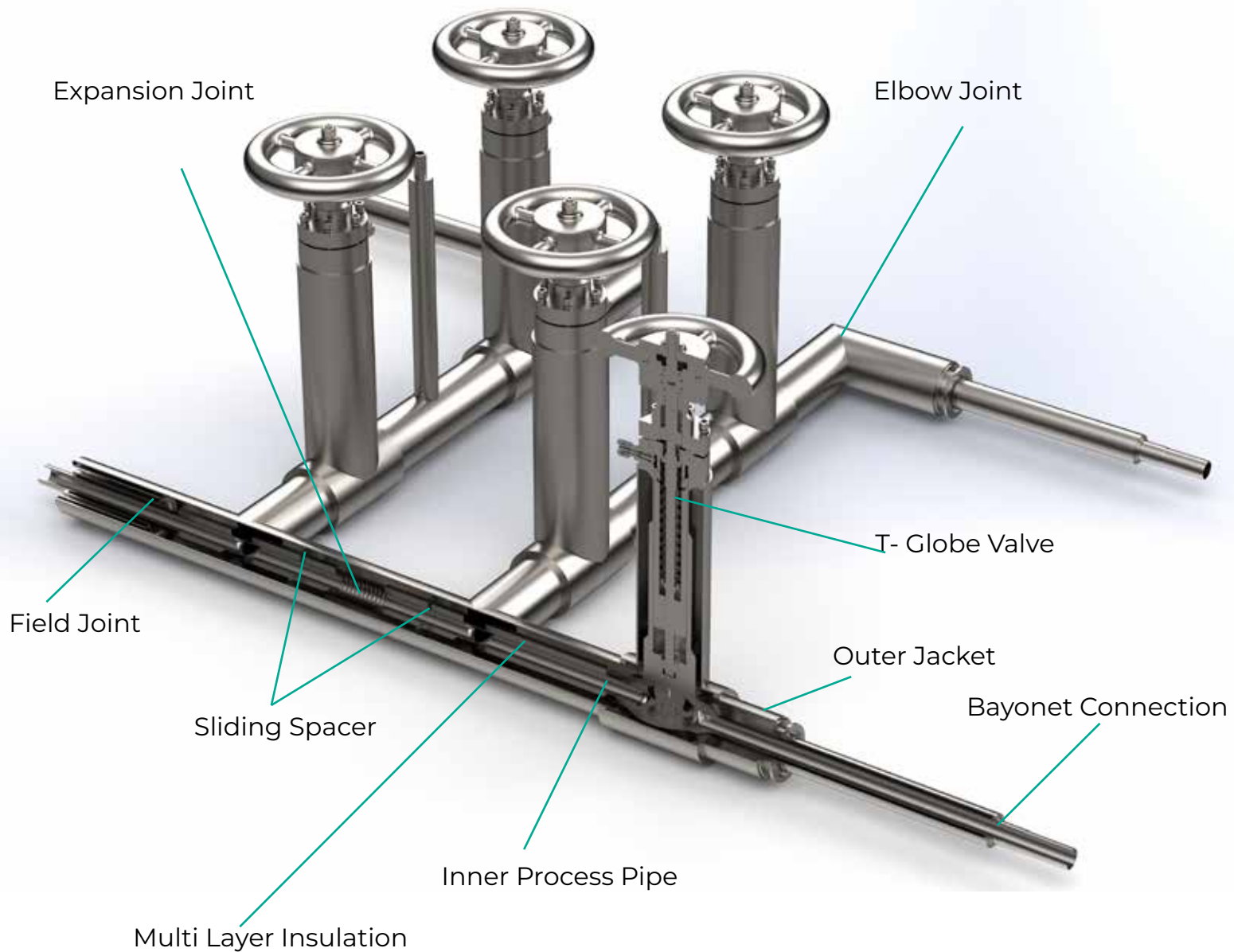
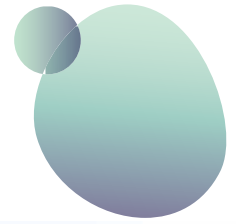

Designed for LH2 and other key industrial gases such as LIN, LOX, LAR, and LNG. Rated to -253°C (-423.4°F)

KEY COMPONENTS



Expansion Joint

An expansion joint is a device that allows for the expansion and contraction of the piping system due to temperature changes. Expansion joints are especially important in VJP systems because cryogenic liquids have a very high coefficient of thermal expansion.



Field Joint

A field joint is a type of joint that is used to connect two sections of VJP piping in the field. Field joints are typically flanged or welded joints.



Sliding Spacer

A sliding spacer is a device that allows for the relative movement of the inner pipe and outer jacket of a VJP system. Sliding spacers are important because they prevent the vacuum jacket from being damaged by the expansion and contraction of the inner pipe.



Multi Layer Insulation

Multi layer insulation (MLI) is a type of insulation that is used in VJP systems to reduce heat transfer from the surrounding environment. MLI consists of multiple layers of reflective material and non-conductive material.



Inner Process Pipe

The inner process pipe is the pipe through which the cryogenic liquid flows. The inner process pipe is typically made of stainless steel.



Bayonet Connection

A bayonet connection is a type of quick-release connector that is used in VJP systems. Bayonet connections are easy to connect and disconnect, and they are typically used to connect the VJP system to the storage tank.



Outer Jacket

The outer jacket is the pipe that seals the vacuum space and forms a "vacuum jacket." The outer jacket is typically made of stainless steel.



Photos provided as courtesy by CHART



PRODUCT APPLICATIONS

Vacuum jacketed storage tank fill and withdrawal assemblies are the next generation of cryogenic fluid transfer technology. These fully customizable manifolds are designed to support all storage tank and trailer layouts, while minimizing heat transfer rates and maximizing flow rates.

1

Primary Target: LH2

Liquid hydrogen (LH2) is an extremely cold cryogenic fluid with a boiling point of -252.9°C . This makes it ideal for use in applications where extreme temperatures are required, such as aerospace propulsion and fuel cells.

One of the biggest challenges in handling LH2 is heat loss. Due to its extremely low temperature, LH2 is very good at absorbing heat from the surrounding environment. This can lead to significant boil-off, which can waste product and increase costs.

Vacuum jacketed storage tank fill and withdrawal assemblies are ideal for handling LH2 because they minimize heat transfer. The vacuum jacket creates a barrier between the LH2 and the outside environment, which helps to keep the LH2 cold and reduce boil-off.

In addition, vacuum jacketed assemblies are designed to maximize flow rates. This is important because LH2 is a very viscous fluid. By maximizing flow rates, vacuum jacketed assemblies can help to reduce pumping costs and improve operational efficiency.

2

Secondary Target: LN2

Liquid nitrogen (LN2) is another commonly used cryogenic fluid with a boiling point of -195.8°C . LN2 is used in a wide range of applications, including industrial manufacturing, food processing, and medical research.

One of the key advantages of LN2 is its large addressable market. LN2 is used in a wide variety of industries and for a variety of purposes. This makes it a very attractive target market for vacuum jacketed storage tank fill and withdrawal assemblies.

In addition, vacuum jacketed assemblies can help to reduce the cost of LN2 operations. By minimizing heat transfer and maximizing flow rates, vacuum jacketed assemblies can help to reduce boil-off and pumping costs.

HOW TO ORDER

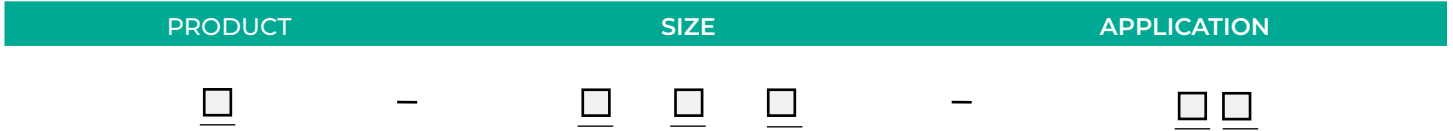

* ORDER EXAMPLE AVAILABLE BELOW

PRODUCT	
M	Manifold Pipe System

SIZE	
005	1/2"
010	1"
015	1 1/2"
020	2"
030	3"
040	4"

APPLICATION	
H2	Hydrogen
HE	Helium
N2	Nitrogen
AR	Argon
NG	Natural Gas
O2	Oxygen

ORDER EXAMPLE: M-010-N2

1" size Manifold Pipe System for cryogenic Nitrogen application

UNIT CONVERSION DATA FOR CRYOGENIC LIQUIDS

	WEIGHT		GAS		LIQUID	
	pounds (lbs)	kilograms (kg)	cubic feet (scf)	cu meters (Nm ³)	gallons (gal)	liters (l)
1 pound	1.0	.4536	192	5.047	1.6928	6.408
1 kilogram	2.205	1.0	423.3	11.126	3.377	14.128
1 scf gas	.00521	.00236	1.0	.02628	.00882	0.03339
1 Nm ³ gas	.19815	.08988	38.04	1.0	.3355	1.2699
1 gallon liquid	.5906	.2697	113.4	2.981	1.0	3.785
1 liter liquid	.15604	.07078	29.99	.7881	.2642	1.0

CRYOGEN	BOILING POINT (°F)	CRITICAL PRESSURE (PSIG ^a)	LIQUID DENSITY (g/L)	GAS DENSITY (27°C,g/L)	LIQUID-TO-GAS EXPANSION RATIO	TYPE OF GAS
Argon	-186(-303)	710	1402	1.63	860	Inert
Helium	-269(-452)	34	125	0.16	780	Inert
Hydrogen	-253(-423)	188	71	0.082	865	Flammable
Nitrogen	-196(-321)	492	808	2.25	710	Inert
Oxygen	-183(-297)	736	1410	1.4	875	Flammable
Methane	-161(-256)	673	425	0.72	650	Flammable
CO ₂	-79(-108)	1071	100	20	535	Inert

NOTES

Area for handwritten notes, consisting of alternating light green and white horizontal stripes.



INNOVATION DRIVEN BY YOUR NEEDS

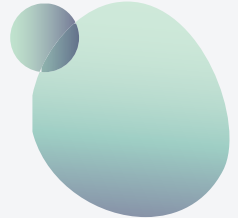

Our businesses are known for proprietary and differentiated technology, quality and reliability, deep vertical expertise, and responsiveness to unique customer needs.

brands you trust.



Corporate Office:

CRANE CHEMPHARMA & ENERGY
4526 Research Forest Drive,
Suite 400, The Woodlands, TX 77381
USA
Tel.: +1-936-271-6500

CRANE ChemPharma & Energy