

SAUNDERS[®] P345 is a polymer based piston operated pneumatic actuator designed to provide superior performance in bioprocess applications.



NEW! REDUCING CO₂ EMISSION IMPACT ON ENVIRONMENT BY 11%

KEY FEATURES INCLUDE:

- ✓ **4.5 BAR OPERATING PRESSURE**
Energy efficiency through reduced air consumption
- ✓ **INDUSTRY LEADING CLOSURE PERFORMANCE**
Up to 10 bar at 100% ΔP for rubber and 6 bar for PTFE diaphragms
- ✓ **25% LIGHTER CONSTRUCTION**
Lighter compared to stainless steel actuators
- ✓ **ECO-FRIENDLY**
14 ton of CO₂ emission reduction driven by lower operating pressure than other actuators



SAUNDERS[®] P345 Actuator

RELIABLE PERFORMANCE

Design philosophy focused on delivering high cycle life, lower air consumption and a compact design versus diaphragm type actuators.

HYBRID CONSTRUCTION

Polished 316 Stainless Steel
Glass filled polyamide combined to create a reliable and captivating device able to withstand typical wash down regimes in the pharma industry.

LIGHTWEIGHT ACTUATOR

Cutting edge polymer cap design achieving 25% weight reduction for Bio-Pharma applications.

PISTON ACTUATION

Innovative piston design for a reduction in operating pressure by 25% compared to market equivalents.

EASY CHANGE OUT

Modular plug-N-play design offering easy change out of compressors.

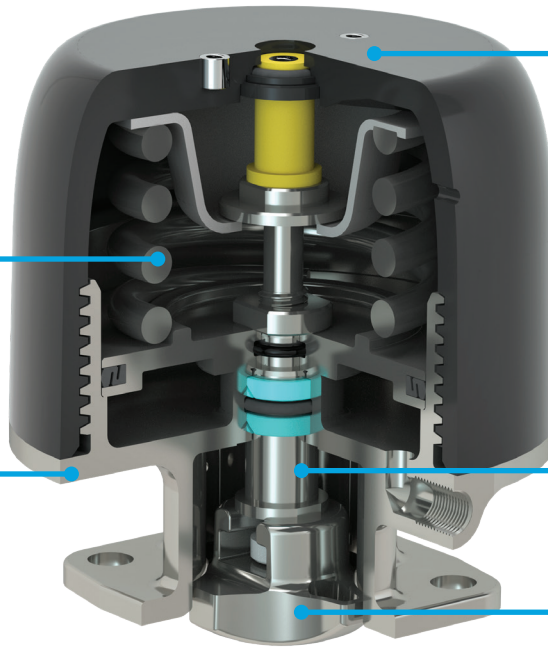

Size Range

- DN8 (0.25") – DN50 (2.00")

Modes of Operation

- Spring-to-Close

Material of Construction

- Actuator Shell: Polyamide
- Bonnet: Stainless Steel

Temperature

- Max: 100°C (212°F)
- Min: -10°C (14°F)

Accessory Options

- Saunders –VUE Sensors (Direct Mount)
- Limit open Stop (Spring-to-Close Mode)
- Positioners

Diaphragm Interchangeability

- Unique compressor design that permits easy conversion of the compressor between rubber and PTFE Diaphragms

Product Marking

- Valve Size
- Mode of Operation
- Operating Pressure
- Date of Manufacturing