



**NEW!** MAXIMIZING VALVE LIFE IN EXCESS OF 3 M CYCLES

**SAUNDERS<sup>®</sup> Angle Seat Valves**  
Engineered for high flow, rapid cycle  
hygienic applications

## About SAUNDERS<sup>®</sup>

### About Crane Co.

Crane Co. is a diversified manufacturer of highly engineered industrial products. Founded in 1855, Crane has over 11,000 employees operating globally and is traded on the New York Stock Exchange (NYSE:CR). The SAUNDERS<sup>®</sup> brand is part of Crane ChemPharma & Energy (within Crane Co's Process Flow Technologies segment) which designs and manufactures a variety of high performance fluid handling products destined for the most demanding corrosive, erosive and high purity applications. Crane solves customers' toughest challenges in the chemical, biopharmaceutical, oil & gas, refining, and power generation industries.

### About SAUNDERS<sup>®</sup>

Since P.K. Saunders invented the original diaphragm valve in 1928, SAUNDERS<sup>®</sup> has led the way in providing class-leading fluid handling solutions to a diverse range of critical industries. The SAUNDERS<sup>®</sup> brand remains synonymous with security, reliability, and trouble-free operation in meeting the challenge of corrosive and abrasive industrial applications as well as providing zero deadleg, intelligent sensing aseptic solutions to the Life Science industry. Simplicity in design coupled with over 80 years of cutting edge innovation has resulted in SAUNDERS<sup>®</sup> diaphragm valve technology handling a wider range of fluids than any other valve type.



SAUNDERS<sup>®</sup> manufacturing site Cwmbran, Wales 1939.



### Fluid handling solutions for demanding sterile applications

SAUNDERS<sup>®</sup> applies a unique understanding of aseptic valve technology, in-house polymer core competence and class leading sensing/controls to deliver unrivalled processing solutions to our customers in the Clean Process industries.

SAUNDERS<sup>®</sup> diaphragm valves lie at the heart of every Biopharmaceutical process and play a key role in controlling flow of high value, sterile media, many of which become the next generation Biologic drugs and life saving vaccines of tomorrow.

The same focus and dedication to innovation has now been applied to the development of a complementary Angle Seat Valve to further extend the SAUNDERS<sup>®</sup> Life Science portfolio. The new Angle Seat Valve range is underpinned with the unique assurance and quality of the SAUNDERS<sup>®</sup> brand providing unrivalled reliability and outstanding service life.



Aseptic Diaphragm Valve



Angle Seat Valve

# Technical Specification

## Temperature Range

- Ambient -10 to 60°C (14 to 140°F)
- Operating Max PTFE Seat -10°C to 180°C (14 to 356°F)
- Operating Max PEEK Seat -10°C to 220°C (14 to 428°F)

## Working Pressure

- 25bar (262psi) dependant on actuator selection
- Suitable for vacuum up to 20mbar

## Testing

- BS EN 12266-1 Leakage Rate A (Air)
- ANSI Class VI

## Operating Modes

- Normally Close NC
- Normally Open NO
- Double Acting DA

## Surface Finish

- <3.2µm Ra Internal Mechanical/EP
- 0.4, 0.6, 0.8µm Ra Mechanical/EP on request

## Size Range

- DN15-50 (0.5" to 2.0")

## Materials

- Actuator Corrosion Resistant Glass Filled Nylon
- Body S Steel 316L Investment  
Cast CF3M ASTM 351 (DIN 1.4409)
- Seat PTFE (Option PEEK)

## Compliance/Certification

- FDA Conformance PTFE Seat, Shaft Bearing, V Seal Gland Packing
- PED/CE
- EN10204 3.1 Traceability (Media Contact Parts)

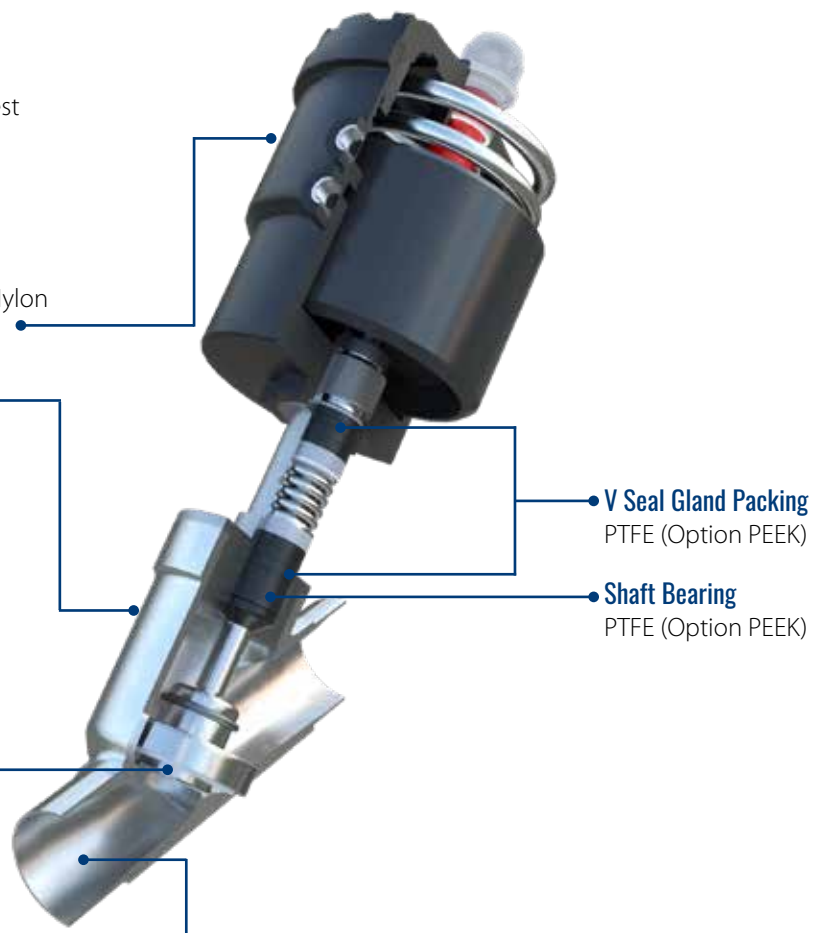

## Port Connections

- ASME BPE OD Butt Weld
- ASME BPE Clamp EN558-1 Series 1 Face to Face

## Features and Benefits

### SAUNDERS<sup>®</sup> Angle Seat Valves

Engineered for high flow, rapid cycle hygienic applications, the SAUNDERS<sup>®</sup> Angle Seat Valve combines a number of innovative design features to maximise service lifetime, minimise the need for routine or unplanned maintenance and optimise performance efficiency. The SAUNDERS<sup>®</sup> Angle Seat Valve represents the ideal choice for on/off and control applications and offers outstanding service life (factory tested in excess of 3 M Cycles).

With the SAUNDERS Angle Seat Valve, **security, reliability and repeatability** are ensured across the spectrum of challenging clean utility applications in Life Science, Food and Beverage and Cosmetics processing.



#### LONGER SERVICE LIFE

Self aligning disk, multi layered spring loaded V Seal gland packing and polished stem interface ensure low friction operation and outstanding service life



#### MAINTENANCE FREE DESIGN

Highly engineered self adjusting packing system and self aligning seat eliminate need for routine maintenance, saving significant operational costs and unplanned downtime



#### EFFICIENT OPERATION

360° head rotation permits ease of mounting, installation and operation

## Features and Benefits

The SAUNDERS<sup>®</sup> Angle Seat Valve presents a compact, minimum maintenance, “fit and forget” solution. The simplicity and innovation of Saunders design is built around key features that provide unrivalled service life and reduce or eliminate unplanned maintenance.

The universal, single body design is good for both low and high pressure applications, and is perfectly suited for liquids (clean or with particulates), steam and gas service as well as vacuum up to 20mbar.

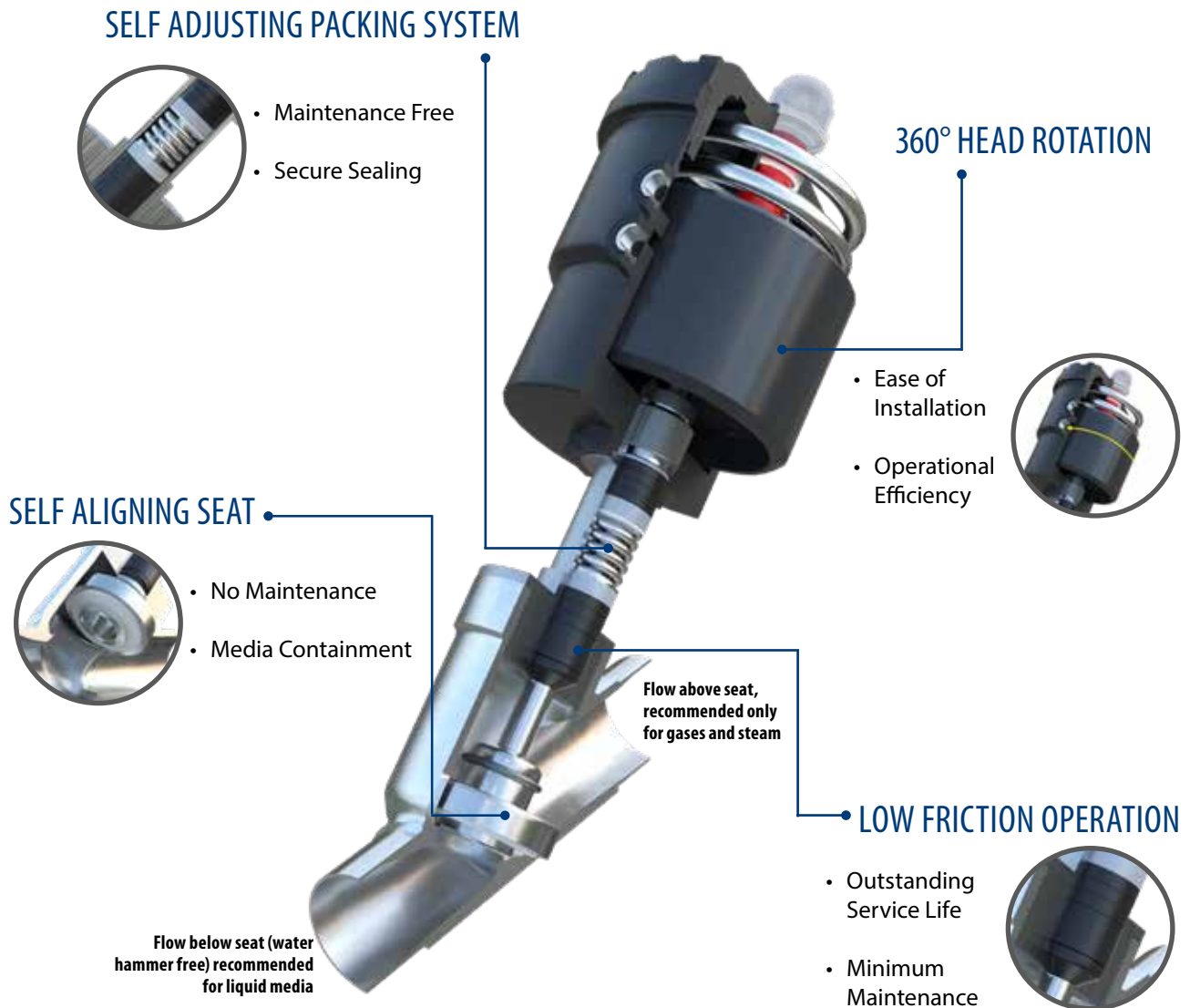

The SAUNDERS<sup>®</sup> range of Angle Seat Valves delivers outstanding service life across a spectrum of high flow, rapid cycle utility applications. Tested and validated at greater than 3 M cycles.

## Design Features



The SAUNDERS® Angle Seat Valve is designed with optimum seat position incline meaning flow is minimally impeded in open position. This results in excellent flow and low pressure loss.

**Self Aligning Seat** ensures media containment and repeatable, maintenance-free operation. Its engineered design permits a flexible, controlled movement as the valve is closed to self adjust and align on the orifice seat. Sealing is 100% ensured.

Unique **Self Adjusting Spring Loaded V Seal Gland Packing** maintains constant pressure on stem packing providing a high integrity and secure sealing arrangement. It prevents both emission of the working media into the actuator and penetration of foreign matter into the working media from external environment. This ensures trouble-free operation, avoids any unplanned maintenance and optimises total cost of ownership.

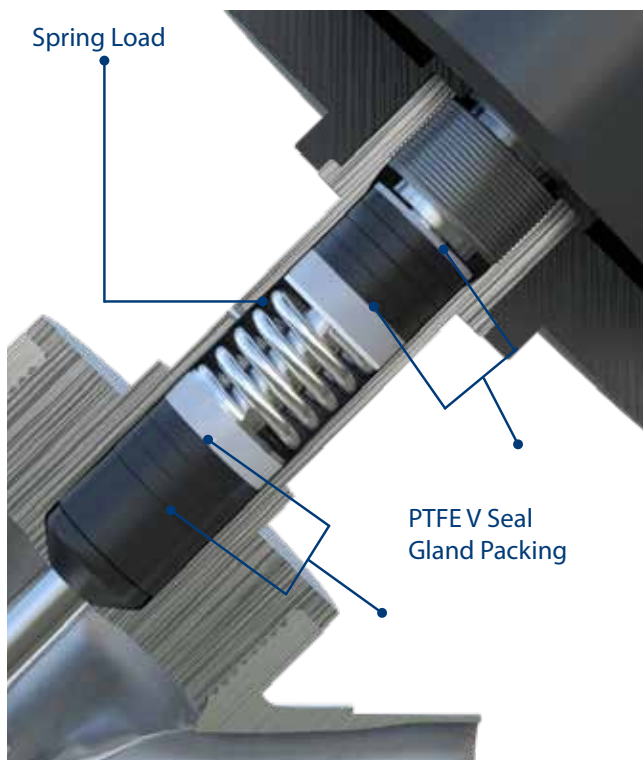

## Design Features

The SAUNDERS<sup>®</sup> compact high performance polymer actuator allows full 360° head rotation which facilitates ease of installation, mounting and operation. This removes risk of possible exhaust air contamination and sedimentation of particles in operator crevices. Air port alignment can be configured in any desired position to suit system layout and operation.

Stainless Steel  
Insert Air Ports

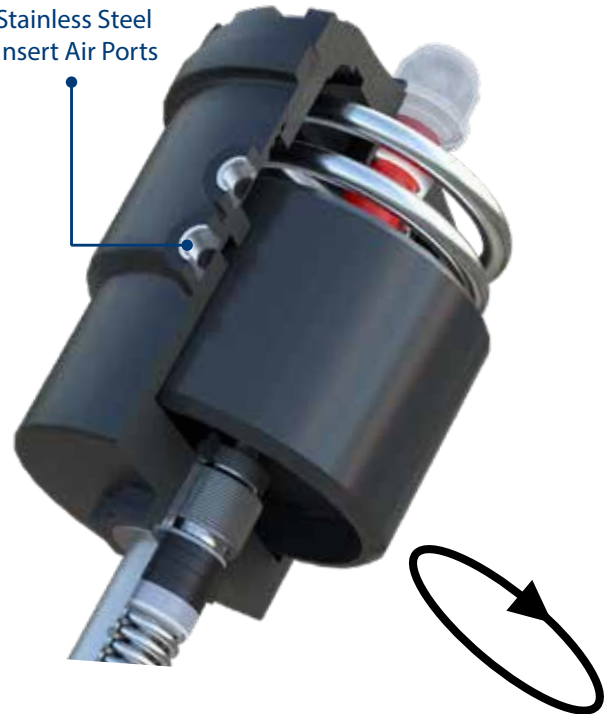

360 Degree head rotation

Low Friction  
Contour Wiper

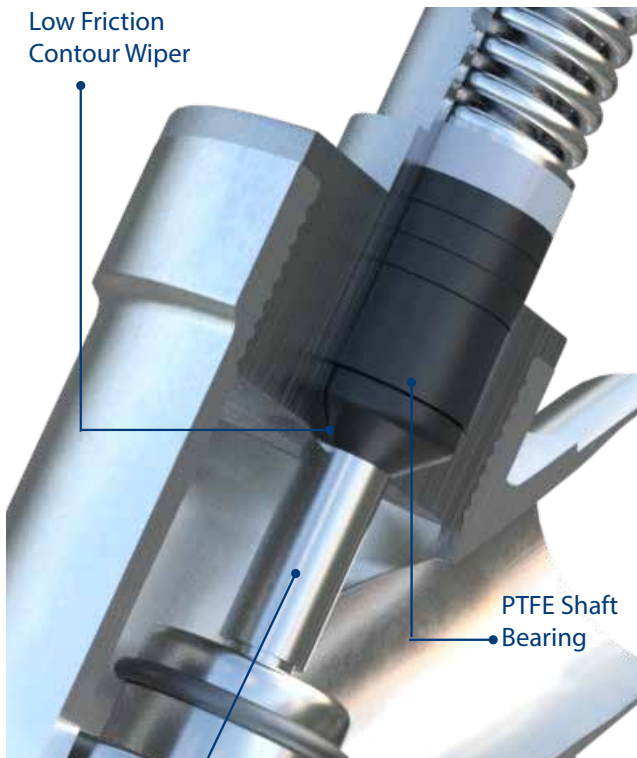

PTFE Shaft  
Bearing

Precision Polished Spindle interface

Maintenance-Free design provides a perfect fit for high cycle life application. The SAUNDERS<sup>®</sup> Angle Seat design has a **precision, engineered interface** between sealing system and dynamic components to provide the security and longevity of low friction operation. To further guarantee repeatable operation, a contoured wiper ring protects the spindle from possible contamination and damage.

## Class Leading Accessory Platform

**Intelligent class-leading accessory platform delivers unrivalled accuracy and total cost of ownership savings**



### **VUE Intelligent Sensors**

- Industry-leading automation technology
- State of the art continuous electro magnetic sensing technology
- Contactless calibration operation with no routine maintenance
- Offers remote diagnostics to optimise preventative maintenance



### **Powerflow Intelligent Positioners**

- Microprocessor controlled digital valve positioner
- Ease of operation via OLED display and keypad
- Positioner adjusts valve stroke quickly and accurately utilizing an automatic control algorithm and pulse width modification control technology



# Applications

Used to regulate the flow of liquids, gases, steam and vacuum, the SAUNDERS® Angle Seat Valve is ideally suited to the demands of hygienic processing applications in Life Science, Cosmetics and Food & Beverage industries.

- High flow rate perfectly suited to steam, heat exchange and control applications
- Fast cycling capability (500 ops/hr single acting, 1000 ops/hr Double Acting)
- High temperature (PTFE Seat/Seal 180°C, 356°F, PEEK option 220°C, 428°F)
- Maximum viscosity up to 500mm<sup>2</sup>/s
- Suitable for vacuum application up to 20mbar
- Compact construction (reduces vertical installation space)

## Media

- Liquids – water, glycol, salt solution, organic solvents, oils, alkalis, cooling lubricant
- Steam – industrial steam, saturated steam, sterile steam
- Gases – air, nitrogen, oxygen

## Applications

- Generation and distribution of industrial and sterile steam
- Freeze drying/lyophilisation
- Autoclave/steam sterilisers
- Cleaning and sterilisation (chemical and steam)
- Pure water generation
- High purity water pre treatment
- Electro deionisation skids
- Generation of sterile compressed air, biogas
- Medical grade washing systems
- Sterile air filtration
- Hygienic cleaning/decontamination systems
- Ultra filtration pre treatment (WFI water)
- Heat exchanger systems
- Steam distillation of essential oils
- Batch and filling processes
- Keg cleaning/filling/sterilisation

## Industries



Biotech



Pharmaceutical



Food



Cosmetics



Beverage

# Eliminating Risk of Water Hammer

Water Hammer is defined as a pressure surge when an incompressible fluid is forced to stop suddenly in a closed system. The cumulative effect of these pressure waves may cause damage to valves and surrounding equipment. Quarter turn style valve technologies (ball) may pose a particular risk of water hammer due to their “quick closure” design. Below we compare a typical quarter turn ball valve design with the angle seat design.

## BALL VALVES

## ANGLE SEAT VALVES

### Valve is Closed



Regular seal re-tightening required as the ability to maintain pressure in packing area is compromised after a small amount of seal wear. High ongoing maintenance cost.



Self aligning seat adjusts and aligns on orifice seat to guarantee sealing integrity and maintenance free operation. Self adjusting spring loaded gland packing system maintains constant pressure on the stem packing and is not impacted by seal wear.

### Valve Opens

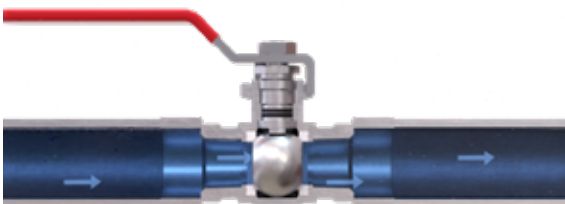

Valve opens through 90° or quarter turn rotation. Requires high torques, large actuators and more air to move. Generally poor control suitability.



Valve opens through controlled linear movement. Optimum seat position incline means flow is minimally impeded in open position. Results in excellent flow and low pressure loss.

### Valve Closes



Sudden closure of ball valve may cause pressure surges and possible damage to valves and system.

- Valve damage normally exhibited by premature seat wear/failure.
- System efficiencies may be impacted by leaks with significant increase in maintenance downtime.



Flow path through Angle Seat Valve is smooth and controlled. Dissipates any surge in pressure as valve closes. No risk of water hammer.

## How SAUNDERS® Angle Seat Valves eliminate risk of water hammer

Correct selection of SAUNDERS® Angle Seat Valves eliminates risk of water hammer as the design permits controlled closure and allows any pressure surge to dissipate past the seat. There is no risk of valve or system damage and no unplanned maintenance downtime.

## Performance Summary

### SAUNDERS<sup>®</sup> Angle Seat Valve

Design is inherently maintenance free and ensures consistent, repeatable, trouble free operation over millions of cycles. The self adjusting spring loaded V seal gland packing system maintains constant pressure on the stem packing and is not impacted by seal wear. The self aligning disk requires no maintenance.



### MAINTENANCE-FREE DESIGN – SIGNIFICANT REDUCTION IN TOTAL COST OF OWNERSHIP

- Security of operation guaranteed
- No unplanned downtime
- Major total cost of ownership savings
- Outstanding service life >3M cycles

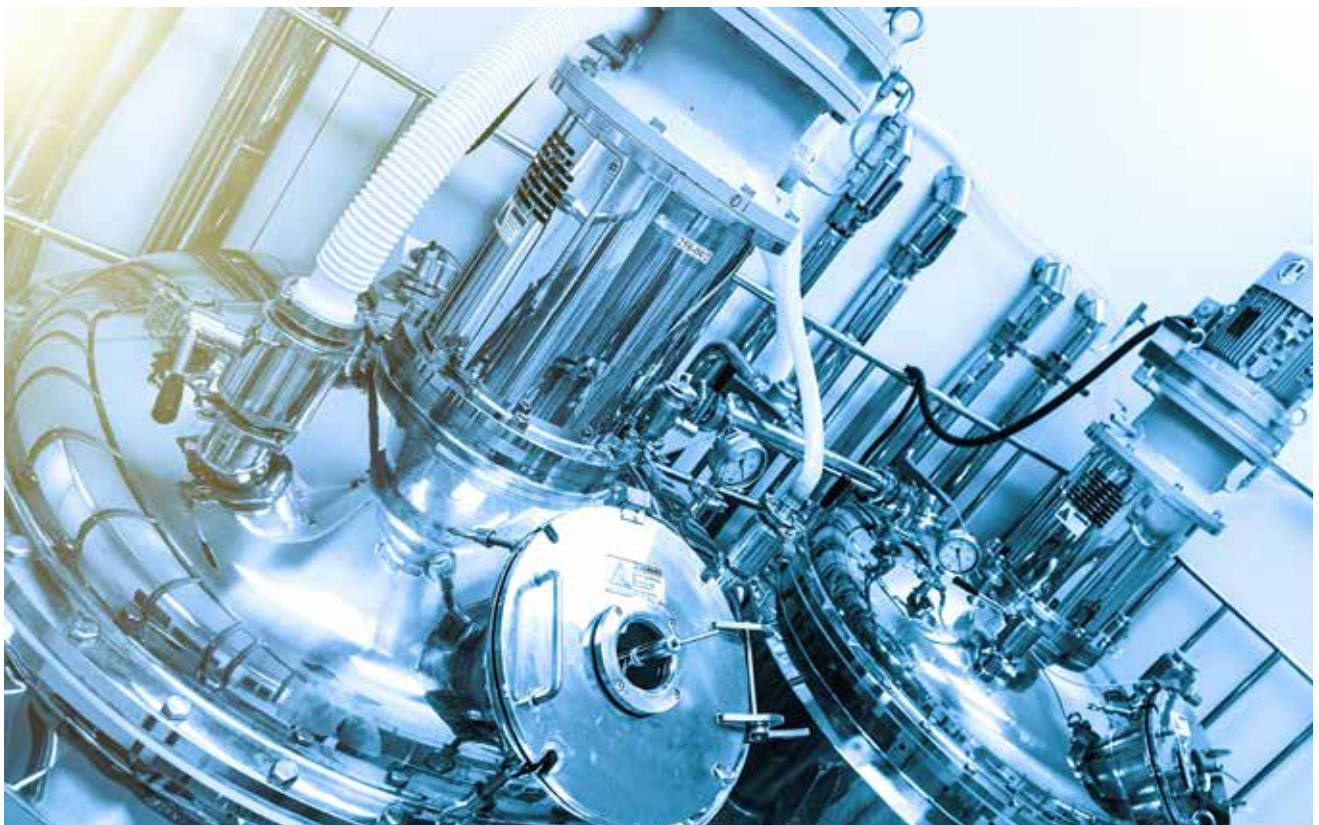

# CRANE®

---

**CRANE CHEMPHARMA & ENERGY**

4526 Research Forest Drive,  
Suite 400  
The Woodlands  
Texas 77381, U.S.A.  
Tel.: +1 936 271 6500

Crane Process Flow Technologies Ltd.  
Grange Road  
Cwmbran, Gwent NP44 3XX  
United Kingdom  
Tel.: +44-1633-486666

Crane Process Flow Technologies Ltd.  
Solitaire, 5th & 6th Floor, S.No. 131 /  
1+2, ITI Road, Aundh,  
Pune - 411007 India  
Tel: +91 20 3056 7800

Crane Process Flow Technologies  
BVBA/SPRL  
Avenue Léonard de Vinci 11  
1300 Wavre, Belgium  
Tel.: +32-10 8184444

---

Crane Co., and its subsidiaries cannot accept responsibility for possible errors in catalogues, brochures, other printed materials, and website information. Crane Co. reserves the right to alter its products without notice, including products already on order provided that such alteration can be made without changes being necessary in specifications already agreed. All trademarks in this material are the property of the Crane Co. or its subsidiaries. The Crane and Crane brands logotype (CENTER LINE®, COMPAC-NOZ®, CRANE®, DEPA® & ELRO®, DOPAK®, DUO-CHEK®, FLOWSEAL®, GYROLOK®, GO REGULATOR®, HOKE®, JENKINS®, KROMBACH®, NOZ-CHEK®, PACIFIC VALVES®, RESISTOFLEX®, REVO®, SAUNDERS®, STOCKHAM®, TEXAS SAMPLING®, TRIANGLE®, UNI-CHEK®, VALVES®, WESTLOCK CONTROLS®, WTA®, and XOMOX®) are registered trademarks of Crane Co. All rights reserved.