



PACIFIC VALVES

WEDGEPLUG

TECHNICAL DATASHEET

PROVEN PERFORMANCE IN THE MOST SEVERE SERVICE APPLICATIONS

WEDGEPLUG™
METAL SEATED VALVES
FROM PACIFIC VALVES®

CRANE



www.cranecpe.com



WEDGEPLUG™ Key Features

Key Features & Benefits

- 1 Simple construction with only three major parts
- 2 Simple purge options
- 3 Metal sealing surfaces
- 4 Wedgetorque® operator
- 5 Bi-directional sealing with double block-and-bleed capability
- 6 Purge acts as secondary seal barrier for more reliable shutoff
- 7 Wide seat area accommodates long term process damage and supports reliable isolation performance



WEDGEPLUG™ History of Innovation.....4
 Long Service Life Reference List.....5
 WEDGEPLUG™ Complete Range/Installations.....6
 Figure Number & Ordering Information7
 WEDGEPLUG™ Comparison.....8
 Estimated Steam Consumption9
 Design Features..... 10-11
 Purge/Flush and Automation Data 12
 Steam Jacketed..... 13
 WEDGEPLUG™ Special Options..... 14-16
 Materials of Construction 17
 ASME Class 300 • 70% Port • Sizes 1 ¼" - 20" 18-19
 ASME Class 150 • 90% Port • Sizes 6" - 24" 20
 ASME Class 300 • 90% Port • Sizes 6" - 30" 21
 ASME Class 300 • 100% Port • Sizes ½" - 14" 22
 ASME Class 300 • 100% Port • Sizes 14" - 30"..... 23
 ASME Class 600 • 100% Port • Sizes ½" - 14" 24
 ASME Class 900 • 100% Port • Sizes ½" - 12" 25
 ASME Class 1500 • Trunnion Type..... 26

PACIFIC VALVES® reserves the right to change or modify product design or construction without prior notice and without incurring any obligation to make such changes and modifications on products previously or subsequently sold.



WEDGEPLUG™ History of Innovation

The Early Years

In the late 1920s, a maintenance engineer for a major U.S. oil company recognized the need for a valve that could withstand the rigors of catalyst service in fluidized catalytic cracking units. The engineer developed a lift-type, non-lubricated plug valve that would lift, rotate and reseal the plug in a single motion. This gear-operated valve (shown below) was designed as an on-off isolation valve.

In the early years of production, WEDGEPLUG™ valves were manufactured in sizes from 1 to 30-inches with various port openings rated to 150, 300 and 600 ASA (now known as ASME). The product line was later expanded to include steam jacketed valves so that the WEDGEPLUG™ could be used effectively in handling viscous liquids such as tars and pitches.

In 1952, Stockham Valves & Fittings acquired WEDGEPLUG™ valves and relocated operations from New Orleans, Louisiana to Birmingham, Alabama. With the added resources and capital that Stockham provided, product enhancements became a priority. A screw-type operator and the O-Seal plug were developed and incorporated into the WEDGEPLUG™ design.

The screw-type operator

replaced the existing cam-type device and vastly improved the operating performance of the valve by lifting the plug vertically, rotating it 90 degrees and then reseating it by applying torque to a wrench, handwheel, gear operator or actuator. The new design accommodated lift variations which occur when line temperature varies.

O-Seal valves were designed with two Teflon® O-rings inserted into dovetail grooves on the plug faces providing vapor-tight shutoff on both upstream and downstream seats. The O-Seal design allowed WEDGEPLUG™ valves to be used in other applications including fueling facilities, tank farms and loading and unloading stations.

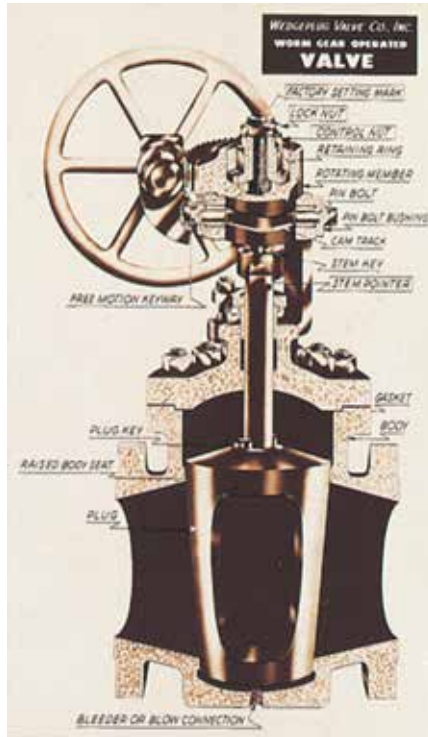

Product Innovations

The ensuing years brought other design enhancements to the WEDGEPLUG™ product line including:

- Balanced stems and trunnion mount for high differential pressures
- Extended bonnets for cryogenic service
- Heat-dissipating fins for temperatures exceeding 1000°F
- Additional sizes with 90% and 100% port openings to accommodate higher flow rates
- The Wedgetorque® operator, replacing the less efficient cam-type.

Teflon® is a registered trademark of DuPont.



Long Service Life Reference List

The below history and reference list is just a sampling of users who have used WEDGEPLUG™ valves in critical service coker applications for a minimum of 15 years. A full reference list and contact information is available. There are 1000's of WEDGEPLUG™ valves installed in critical service coker facilities worldwide.

1927	First WEDGEPLUG™ Installation	New Orleans, Louisiana	
mid to late 1930's	Coker Process Developed		
1950's	Maraven Installation	Cardon, Venezuela	4 Coke Drums
1950's	Logaven Installation	Puento Fuego, Venezuela	4 Coke Drums
1952	Stockham Valves acquires WEDGEPLUG™		
1954	Ultramar (ex Diamond Shamrock) Installation	Carson, California	4 Coke Drums
1958	Exxon / Mobil Installation	Beaumont, Texas	8 Coke Drums
1959	Conoco Phillips (ex Alliance) Installation	Bellechase, Louisiana	4 Coke Drums
1960's	Conoco Phillips Installation	Humberside, United Kingdom	8 Coke Drums
1960's	Conoco Phillips Installation	Europe	2 Coke Drums
1961	Exxon / Mobil Installation	Chalmette, Louisiana	8 Coke Drums
1962	Conoco Phillips Installation	Carson, California	6 Coke Drums
1965	Shell Installation	Norco, Louisiana	4 Coke Drums
1965	Shell Installation	Bakersfield, California	2 Coke Drums
1965	Valero Installation	Corpus Christi, Texas	2 Coke Drums
1968	BP (ex ARCO) Installation	Carson, California	6 Coke Drums
1968	Shell Refinery Installation	Cherry Point, Washington	2 Coke Drums
1968	Valero (ex Coastal) Installation	Corpus Christi, Texas	4 Coke Drums
1970	BP (ex ARCO) Installation	Cherry Point, Washington	4 Coke Drums
1970	Citco Installation	Corpus Christi, Texas	4 Coke Drums
1971	Petro Canada Installation	Edmonton, Alberta	2 Coke Drums
1974	Chevron Installation	Pascagoula, Mississippi	6 Coke Drums
1974	Chevron Installation	Carson, California	6 Coke Drums
1975	Conoco Phillips Installation	Rodeo, California	4 Coke Drums
1976	Seadrift Coke Installation	Seadrift, Texas	2 Coke Drums
1982	Flint Hills (ex Koch) Installation	Corpus Christi, Texas	2 Coke Drums
1988	Suncor Installation	Ft. McMurray, Alberta	12 Coke Drums
1992	Wedgetorque® Actuator Developed		
1995	Metal Seated Ball Valve enters market		
1997	Pacific Valves takes over WEDGEPLUG™		
2001	WEDGEPLUG™ Operation moved to Long Beach		
2004	Suncor Installation	Ft. McMurray, Alberta	6 Coke Drums
2007	Chevron Installation	Pascagoula, Mississippi	6 Coke Drums
2007	Suncor Voyageur	Ft. McMurray, Alberta	
2008	Conoco Phillips	Roxana, Illinois	4 Coke Drums



WEDGEPLUG™ Complete Range

Size Range

½" - 36" (DN 15 - 900)

Plug Options

Port openings 70%, 90%, 100%
Q-Plug

Pressure Ratings

ASME Class 150 - 1500

End Connections

Raised Face Flanged, RTJ

Body / Plug Materials

Carbon Steel – WCB
Stainless Steel – CF8M
ASTM A-217 – C5
ASTM A217 – C12
WC6
WC9
CFX8 – Incoloy® 800H

Body Configurations

Short Pattern
Long Pattern

Specials

Steam Jacketing
Extended Bonnet & Stem
Manual Gear
Automation

Incoloy® is a registered trademark of Special Metals Corporation



WEDGEPLUG™ installation at Suncor Millennium 2 Coker project, Fort McMurray, Alberta Canada. Electrically actuated 30" full port WEDGEPLUG™, overhead vapor line isolation service.



WEDGEPLUG™ installation at Chicago's O'Hare Airport. O-ring style plug used to supply water to the airport and also used in hot water loop to melt ice on runways.

How to Specify WEDGEPLUG™ Valves

G		A		0		6		OR		R		F	
G - Gear		A - Standard Design		0 - 100%		6 - 600		OR - O-Seal		R - O-Seal		RF - Raised Face	
Type of Operator		Plug Stem Arrangement		Port Opening		Pressure Class		Optional Features		End Connection			
W Wrench		A Standard Design		7 70%		1 150		OR O-Seal		RF Raised Face			
H Handwheel				9 90%		3 300		EB Ext. Bonnet		RJ Ring Joint			
G Gear		B Balance Stem		0 100%		6 600		HD Heat-Diss. Fins		FF Flat Face			
M Motor (Elec or Air)		T Trunnion-Mounted				9 900		S Std. Steam Jacket		SF Special Serr. Finish			
C Cylinder (Air or Hydraulic)						15 1500		J Steam Jacket w/oversized Flgs & Long Face/Face		BW Butt Weld			
								Z Flangeless Design		SE Screwed Ends			
								— No Optional Features		SW Socket Weld			
								T3 Pipeline Std. Trim		GH Grayloc® Hub			
								T6 Pipeline NACE Std.					
								T7 Pipeline NACE (Highly Corrosive)					
								XX Other Pipeline Trims Upon Application					

Product Range: ½" through 30" sizes. ASME Classes 150 through 1500, larger sizes and other pressure ratings may be quoted on application.

See page 27 for WEDGEPLUG™ datasheet.

Grayloc® is a registered trademark of Oceaneering Int.

Wedgetorque® Operator Grouping (Chart is a general guide for sizing, consult Pacific WEDGEPLUG™ Factory for specific details.)

Fig. No.	Valve Size (in.)																	
	1/2	3/4	1	1 1/2	2	2 1/2	3	4	6	8	10	12	14	16	18	20	24	30
71	-	-	-	WT30W	WT30W	WT30W	WT30W WT45G	WT45W WT45G	WT45W WT45G	WT100G	WT100G	WT100G	WT200G	WT200G	WT200G	WT200G	-	-
73	-	-	-	WT30W	WT30W	WT30W	WT30W WT45G	WT45W WT45G	WT45W WT45G	WT100G	WT100G	WT200G	WT200G	WT200G	WT200G	WT200G	-	-
91	-	-	-	-	-	-	-	-	WT100G	WT100G	WT200G	WT200G	WT200G	WT200G	WT200G	WT200G	WT200G WT500G	WT500G
93	-	-	-	-	-	-	-	-	WT100G	WT100G	WT200G	WT200G	WT200G	WT200G	WT200G	WT200G	WT200G WT500G	WT500G
03	WT30W	WT30W	WT30W	WT30W	WT45W WT45G	WT45W WT45G	WT45W WT45G	WT45W WT45G	WT100G	WT200G	WT200G	WT200G	WT200G	WT200G WT500G	WT200G WT500G	WT200G WT500G	WT200G WT500G	WT200G WT500G
06	WT30W	WT30W	WT30W	WT30W	WT45W WT45G	WT45W WT45G	WT45W WT45G	WT45G	WT100G	WT200G	WT200G	WT200G	WT200G WT500G	-	-	-	-	-
09	WT30W	WT30W	WT30W	WT30W	WT45W WT45G	WT45W WT45G	WT45G	WT45G	WT100G	WT200G	WT200G	WT200G WT500G	-	-	-	-	-	-

Notes: Wrench (W) and Handwheel (H) are interchangeable.
Gear (G)



WEDGEPLUG™ Comparison

	WEDGEPLUG™	Metal Seated Ball	Slide Gate Valve
Design	<ul style="list-style-type: none"> a) Simple - only 3 major parts: body, plug and bonnet. b) Torque seated: If small amount of leakage is noticed, an increase in applied torque is used to improve shutoff. 	<ul style="list-style-type: none"> a) Complex - more than 8 major parts, 2 body halves, bellows, bellows sleeve, upstream seat, downstream seat, and ball assembly. b) Position seated - If leakage occurs, there is no way to decrease. The leak will only increase from erosion until the coke unit must shut down and valve is removed for repair. 	<ul style="list-style-type: none"> a) Multiple body flange joints susceptible to thermal expansion issues and fugitive emission paths. b) Multiple internal components, guides, springs and seats can affect service reliability in case of purge loss. c) Large valve profile can be a challenge in existing Coker units.
Sealing Direction	<ul style="list-style-type: none"> a) Bi-directional sealing 	<ul style="list-style-type: none"> a) Uni-directional sealing increases risk. The valve manufacturer must be involved in proper installation. 	<ul style="list-style-type: none"> a) Some models are uni-directional.
Seat	<ul style="list-style-type: none"> a) Non-rubbing lift and turn design prevents wear and galling of the seal surfaces during operation. b) Integral: No voids to allow for coke buildup c) Simple repair: Only two pieces require any possible repair, the plug and body 	<ul style="list-style-type: none"> a) Constantly rubbing sealing surfaces allows wearing and damage by galling during the normal operation of the valve. b) Separate/interference fit: Allows for coke buildup behind the seat and misalignment during installation. c) Complex Repair: The valve must be removed from the piping. One must heat seal to high temperature to remove. Chance of thermal destruction and damage behind the seat. 	<ul style="list-style-type: none"> a) Spring loaded. b) Separate from body so susceptible to misalignment from coke buildup. c) High frictional wear between seat and wedge thus can affect life cycle and maintenance costs.
Spring	<ul style="list-style-type: none"> a) None required 	<ul style="list-style-type: none"> a) Bellows must be used to hold the ball in the seat to maintain isolation. It must be designed using high strength, thin, expensive material like Inconel® 718. b) Complex: Utilizes multiple convolutions, which allows for many areas of coke buildup. c) Requires a protective sleeve to protect and isolate the sensitive bellows from the process. d) Purge is required at the bellows to prevent the bellows from catastrophic damage from normal operating pressures. e) Lapping of bellows is required to prevent massive steam consumption. f) Low spring loads allow for adhered coke on the ball to migrate between the ball and the seat. 	<ul style="list-style-type: none"> a) Susceptible to coke build up if purge is disrupted and this may affect valve sealing capability.
Plug/Ball	<ul style="list-style-type: none"> a) Hardened martensitic stainless steel (Hb 350-400), ground to prevent erosion and adhesion 	<ul style="list-style-type: none"> a) Conventional chrome plating provides a finish of 2-4 RMS that resist coke adhesive. However, chrome plating is a weak mechanical bond with discontinuities known as "holidays". These discontinuities allow permeation of corrosives through the coating. These corrosives attack the bond causing the bond to weaken and fail. 	
Testing	<ul style="list-style-type: none"> a) Valve and trim design is capable of withstanding 100% ASME/API. No "modified" or de-rated test needed. 	<ul style="list-style-type: none"> a) ASME/API test must be "modified" or de-rated to prevent damage to valve internals. 	
Actuation	<ul style="list-style-type: none"> a) Plug does not contact/rub the seat during rotation thus torques are low. This results in smaller actuators and lower capital cost. b) Lower torque is lower work for the actuator, thus the actuator life is increased. c) Plug and seat do not contact during rotation, so torques do not increase after being in service. d) Low torque allows for easy manual operation, with 30-60 turns to open and close. 	<ul style="list-style-type: none"> a) Ball constantly contacts and rubs the seat during rotation causing significant run torques. This results in much larger, expensive actuators being required. b) Increased torque lowers the life expectancy of the actuator. c) Ball and seats in constant contact must wipe or overcome coke buildup on the ball during rotation. The increasing torques after being in service causes jamming. d) High torques require minimum of 100 turns of a handwheel to open and close. 	<ul style="list-style-type: none"> a) MOV adds additional ceiling height to envelope dimension.
Experience	<ul style="list-style-type: none"> a) WEDGEPLUG™ valves have been in delayed coking service since 1954. 	<ul style="list-style-type: none"> a) Only about 15 years in delayed coking service. 	<ul style="list-style-type: none"> a) Less than 10 years Coker isolation experience.
In-Line Repair	<ul style="list-style-type: none"> a) One-piece body allows for the bonnet and plug to be removed, and the seat inspected and cleaned without removing the body from the line. 	<ul style="list-style-type: none"> a) Two-piece split body requires the valve to be removed from the line to allow inspection and cleaning of the internals. 	
In-Line Decoke	<ul style="list-style-type: none"> a) Lift and turn torque seating allows the valve to be decoked in line during operation. 	<ul style="list-style-type: none"> a) Coker unit must be shut down and valve removed in order to be decoked. 	

Inconel® is a registered trademark of Special Metals Corporation

Estimated Steam Consumption

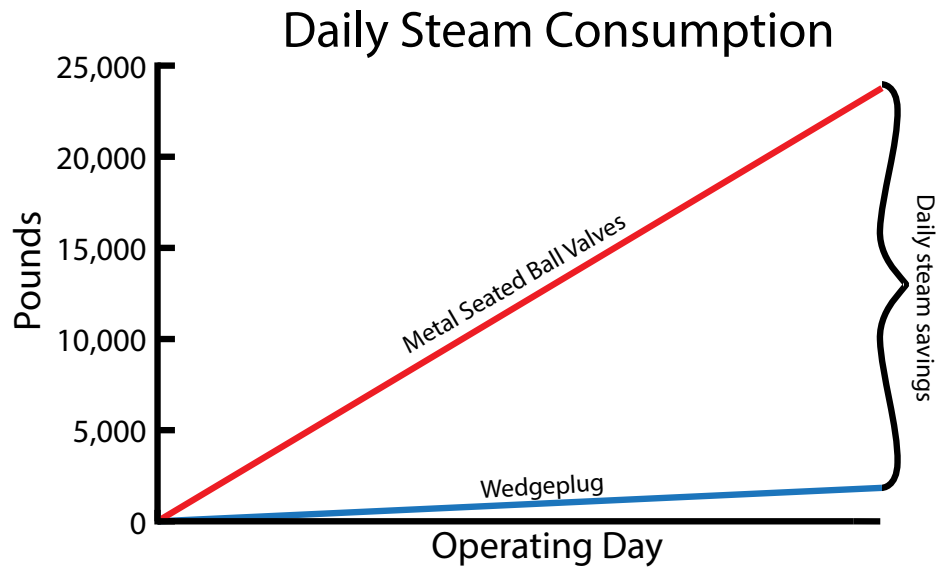

Estimated Steam Consumption for WEDGEPLUG™ versus Ball or Gate Valve

						Steam Consumption (pounds)						
	Valve Size	Qty of Valve	Purge Pipe Size	No. of Purge Connections	Steam Usage	Valve Cycle Time (min)	No. of Valve Cycle/Day	Minutes/Day	Each Valve/Day	Each Valve/ Yr	Total Valves/ Yr	All Valves/Yr
WEDGEPLUG™	4"	4	½"	3	During valve cycle only	0.5	4	2	9.6	3,360	13,440	297,360
	10"	5	1"	3		1	4	4	62.4	21,840	109,200	
	14"	2	1"	3		1	4	4	62.4	21,840	43,680	
	20"	4	1"	3		1.5	4	6	93.6	32,760	131,040	
Ball or Gate valve	4"	4	½"	3	Continuous	2.5	4	1440	6912	2,419,200	9,676,800	96,163,200
	10"	5	1"	3		5	4	1440	22464	7,862,400	39,312,000	
	14"	2	1"	3		5	4	1440	22464	7,862,400	15,724,800	
	20"	4	1"	3		7.5	4	1440	22464	7,862,400	31,449,600	

Notes:

1. Steam amounts shown are maximum, assuming ideal supply and nozzle, with no seat area restraint.
2. No steam is consumed at other times for WEDGEPLUG™. Steam is only consumed when WEDGEPLUG™ is in motion (cycling).
3. Continuous steam consumption in uni-directional Gate valve or Ball valve.
4. Steam consumption rates are based on 25 psig differential pressure (purge steam vs line pressure).
5. Ball valve typically require more purge connections than WEDGEPLUG™. Steam consumption, therefore, will be higher than the above estimate.



Design Features

WEDGEPLUG™ NON-LUBRICATED PLUG VALVE

WEDGEPLUG™ valves are designed to conform to API Standard 599 and API Standard 600 where applicable and are tested to API 598.

WEDGETORQUE® OPERATORS

Patented mechanical operators lift, rotate a quarter-turn, and reseal the plug on its protected seating surfaces. The operators automatically compensate for wear and varied operating conditions. They allow metal plugs to be seated by torque in both open and closed positions. Operator members are made from high-strength steel, heat treated for maximum wear resistance.

Operators - Valves are operated by wrenches, handwheels, or worm gears. Handwheels have finger grips cast on bottom of rim and are fastened with a cap screw and lock washer. Worm-type gearing is completely enclosed in a housing. Valve opens by turning the handwheel counterclockwise. Electric, hydraulic and pneumatic actuation is also available. For motor operation, the gear box is provided with standard mounting flanges.

Body - Raised seating surfaces in bodies are protected when plug is in either open or closed position. Seating surfaces are ground to a mirror-like finish on precision grinding machines. All sizes have seven bosses on body for bleed, drain, and bypass connections. The bottom boss is furnished tapped with standard pipe threads.

Dimensions, drilling and spot-facing end flanges conform to ASME B16.5. Face-to-face dimensions conform to ASME B16.10, covering short pattern, regular and round full port valves except as noted on the catalog pages.

Threaded or butt-weld end valves may be quoted on application.

WEDGEPLUG™ Hard Facings - Hard facings on the plug and body seats of WEDGEPLUG™ valves can be furnished to customer requirements.

The facing is deposited on the plug and body seats and is then machined to a mirror-like surface. The hard facing materials used retain their wearing qualities, corrosion resistance, and hardness at extremely high temperatures. WEDGEPLUG™ steel valves with hard facings are available for high temperature corrosive and erosive steam and oil or oil vapor services. Valves with hard facings are also suitable for severe services at low temperatures. Plugs in austenitic stainless steel valves are regularly furnished in this material. Typical hardfacing includes Stellite®.

Plug - Plugs are cast from materials selected for their nongalling

Graphoil® is a registered trademark of Union Carbide Corp.
Stellite® is a registered trademark of Deloro Stellite.

TYPES OF PORT OPENINGS

Type 7 - 70% port opening, particularly suitable where small pressure drop is desirable

Type 9 - 90% port opening suitable for very small pressure drop

Type 0 - Full round port opening offering minimum pressure loss conditions.

characteristics. Special metals are available on application. Plug taper assures a tight seal and ease of operation.

Stem - High strength stainless steel stems are accurately machined. Large diameter assures strength. Other alloys are available on special order. Trunnions and balance stems, attached to the bottom of the plug, are available for high differential pressures and special installations.

Position Indicator - indicators show whether plug is open or closed and provide a visual indication of the 90° rotation of plug. Indicators can be easily seen from a distance. On valves controlled remotely, the position indicators may be used for microswitch contact.

Bonnet - Bonnets are cast from alloy steels. Special alloys are available on order. Male and female or ring type joint body-bonnet connections are utilized.

Design Features

Packing and Gland Assembly - Two-piece ball and socket-type joints assure alignment and proper compression of packing without binding stem. Packing furnished is Graphoil®. A sacrificial metal inhibitor is compounded into the packing to combat corrosion. Special packing configurations are available. Consult factory when ordering.

Testing and Inspection - WEDGEPLUG™ valves are tested in accordance with API Standard 598, latest revision. Special hydrostatic testing and non-destructive examinations are available. Consult factory when ordering.

Marking - For identification, the following is cast on each valve: the name "WEDGEPLUG™," size in inches, "Steel" alloy grade, and numerals indicating ASME Class. Pressure castings are marked with a foundry heat or melt number, and the physical and chemical properties of these heats or melts are maintained in a permanent record. In addition, a stainless steel nameplate on each valve shows the figure number, size, pressure rating, serial number, and materials of the body, plug and stem.

Trunnion Design

- Supports the weight of the plug in large diameter valves.
- Prevents deflection of the plug in high flow rate conditions.
- Allows valve to be installed in vertical position.
- Provides for adequate flushing of seating area during valve cycle.

Handling Solids in Suspension - When handling solids in suspension, WEDGEPLUG™ valves should be installed with the stem vertical. The boss at the bottom of the valve body is regularly tapped at the factory. This permits easy installation of a bleed and/or blow connection. If permissible to blow back into the line, any purging medium such as air, inert gas, steam, or flushing oil may be introduced through this connection. Then as the plug valve is lifted off its seats, any accumulation below the plug or on the seats will be blown back into the line. Conversely, by opening the bleed, line pressure will blow out any accumulation when the plug is lifted.

Non-Lubricated, Economical - The design of WEDGEPLUG™ valves assures quick, easy opening and closing with no sticking. Expensive plug seal lubricants are not required. The WEDGEPLUG™ valve is equipped with a Wedgetorque® operator which quickly lifts the tapered plug from the body seats, turns it 90 degrees, then reseats the accurately ground plug on the body seats, making a precision metal-to-metal fit.

Note: Valve can be installed at an incline up to 90° and anywhere in between. (Bi-directional so can go in either direction.)

Integral Purge

One piece forged flange and pipe eliminates some welding.

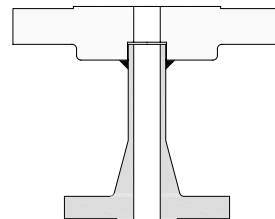

Trunnion Purge

Has the ability to purge through the trunnion to keep both the trunnion and the cavity clean.

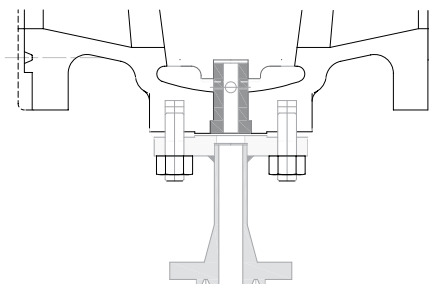

Trunnion Non-Purge

Has the ability to purge through the trunnion to keep both the trunnion and the cavity clean.

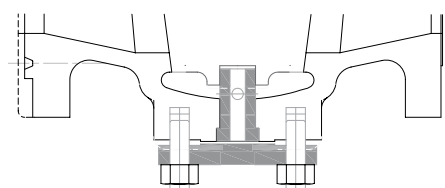



Purge/Flush and Automation Data

BLEED/BLOW CONNECTIONS

An upper barrel boss may also be tapped for a second bleeder and/or blow connection. A line drawing of this arrangement is shown. This also permits circulation of a flushing medium around the plug.

The sectional drawing illustrates the body cavities surrounding the plug. Circulation is provided from the spaces above and below the plug.

If it is necessary to install WEDGEPLUG™ valves in any position other than vertical when handling solids in suspension, it is recommended that an upper barrel boss be tapped. In installing the valve, this boss should be placed on the downward, gravity side. (Consult factory for special installations.)

ACTUATED VALVES - PNEUMATIC, HYDRAULIC OR ELECTRIC

Information needed with inquiry:

1. Valve size and figure number.
2. Service conditions-line media, temperature, and maximum operating differential pressure.
3. Air pressure, hydraulic pressure or electrical supply available to actuator.
4. Opening and closing time required for electric actuators.
5. Weatherproof or explosion proof electric actuator.
6. Type actuator controls and/or accessories required.

Other accessories may be quoted on request.

Notes: Fully opened or closed valve can be purged.
All welded construction no mounting flanges.

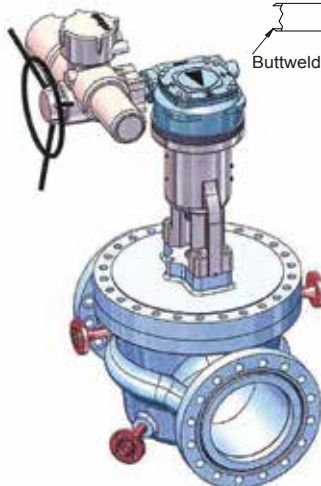
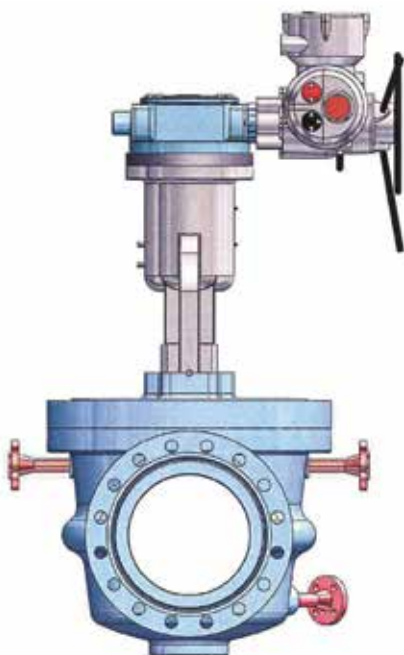
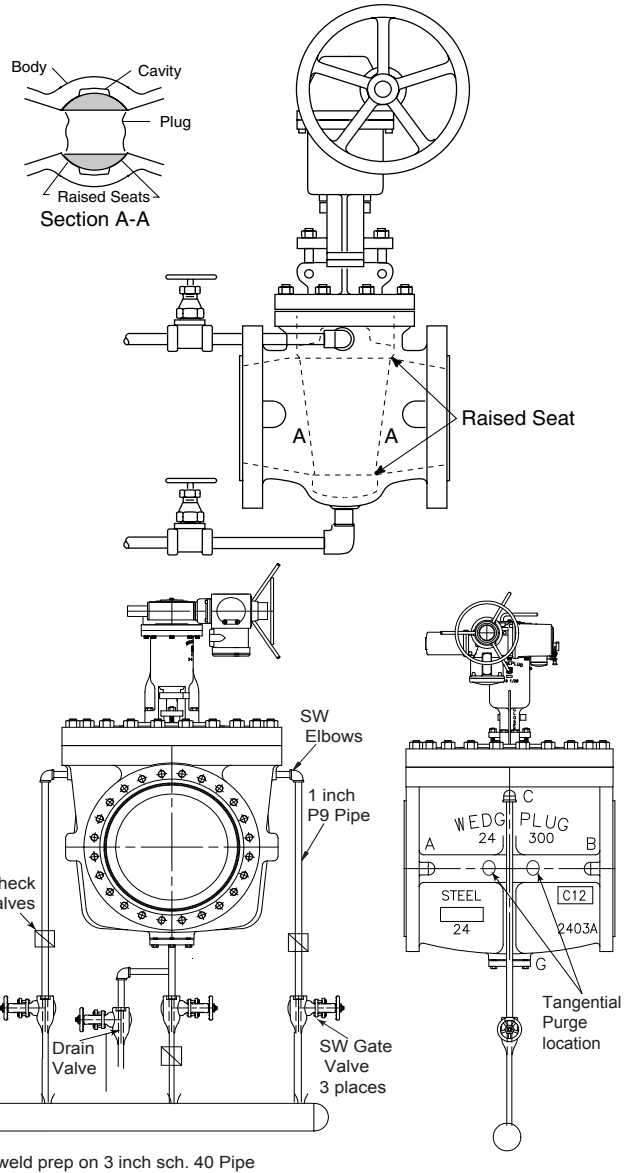

3-D images of Tangential Purge

ASME Class 150 and 300 • Steam Jacketed Valve • Sizes 1½" - 10"

WEDGEPLUG™ valves can be furnished with steam jackets for use on lines carrying any product that will harden or congeal at ordinary temperatures. This allows the injection of a hot fluid (normally steam) into the jacket, keeping the valve and the media warm.

- Refer to page 7 for Ordering Information
- Refer to page 16 for Materials of Construction



Steam Jacketed Body

Valve Size	S-TYPE (M) shown*		J-TYPE (N)	
	70% PORT		70% PORT	
	CL. 150	CL. 300	CL. 150	CL. 300
1 1/2		7.50		9.87
2	7.00	8.50	9.25	10.00
2 1/2	7.50	9.50		
3	8.00	11.12	12.00	12.62
4	9.00	12.00	16.00	
6	10.50	15.87	20.00	21.00
8	11.50	16.50		
10			21.00	

* Special sizes and configurations are available, consult factory when ordering.

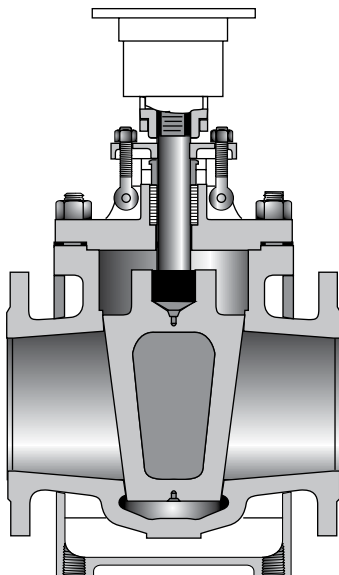

Steam Jacketed Body 'J' Type

Jackets have four bosses – two sided bosses and two bottom bosses tapped in compliance with MSS SP-45.

Special injection arrangements, pressure requirements, and sizes are available.

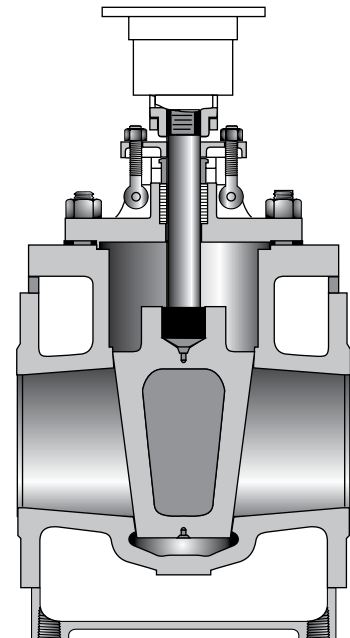

Steam Jacketed Body 'S' Type

All steam jackets are constructed from carbon steel materials and are welded to the valve body. Design pressure is 300 psi unless otherwise noted.



WEDGEPLUG™ Special Options



Extended Bonnet



Steam Jacketed



Typical Shadow Instrument Package

Steam Jacketed (for more information see page 13)

Steam jacketed valves are available to handle high viscous media such as tars and pitches. They may be obtained in ASME Class 150 and 300, sizes 1 1/2 inch through 10 inch.

Extended Bonnet

WEDGEPLUG™ offers an extended bonnet version for either an extreme temperature service condition above 1000°F or when piping structure requires an extended reach to the actuation unit. In the case of extreme high temperature, the purpose of the extended bonnet is to keep the actuator temperature below the point where a breakdown of materials in the actuator will occur. Special alloy materials are available for the construction of extreme high temperature WEDGEPLUG™ such as CF8X or Incoloy® 800H.

Shadow Instrument Package

The purpose of the Shadow Instrument Package is to give absolute positive position feedback of the valve plug. Valves so equipped will indicate seated open, seated closed and percent travel open to closed. Primarily the Shadow Instrument Package is used in conjunction with Electric Actuation systems where precise independent valve position is necessary.

It is important to understand how a WEDGEPLUG™ valve operates. Basically when these valves are operated the plug unseats or lifts up approximately 5/16" - 3/8" while continuing the revolutions of the handwheel or operation of the automated actuator, the plug rotates 90 degrees. The plug then moves down onto the seats again. The problem for automation and PLC's is the first 35% and the last 35% of handwheel or gearhead shaft rotation does not affect flow in any way. This motion only serves to unseat and reseat the valve. The 30% of travel or operation in the middle is when flow rates are affected. If trying to read position from an electric actuator there is no correlation of % open to increase or decrease of flow.

The Shadow instrument package is a system by which both the lift, seat and turning phases of WEDGEPLUG™ valve operation is positively indicated throughout its motion. Rotational motion is completely independent of the valve indicator which can fail in rare instances. The indication of valve plug movement is achieved via two separate instrument systems. First indication is the seated and unseated positions. Indication is provided via Allan Bradley roller proximity switches indicating off the existing valve position indicator. Through these 2 switches, one mounted on each side of the yoke legs, open and closed the down or seated position of the valve plug is signaled. Thus when the plug and indicator start down the individual switch, either open or closed is tripped.

The second indication of valve movement is provided via a single WESTLOCK CONTROLS Model EPICD420R00 switch mounted on the top of the yoke assembly. The yoke is modified to allow the switch to read only the turning portion of valve travel via a positive link directly to the valve stem. Its reading is totally independent of any actuator or the valve yoke assembly. This switch delivers visual as well as 4-20Ma signal on the actual turning portion of the valve travel. It does not read or signal during the raising and lowering of the plug on and off the valve seats. Rotational movement of the actual valve stem and plug is completely independent of the electric actuator or valve indicator. The percent travel as indicated by this switch is directly proportional to increase or decrease of flow unlike that of the electric actuator.

As you can tell the set up is primarily geared for WEDGEPLUG™ valves having electric or automatic actuators such as Limatorque or some other type automated actuator where independent plug position is desired.

WEDGEPLUG™ Special Options

EXAMPLES OF WEDGEPLUG™ DESIGNS ARE:

- A**
 - 8"
 - 100% port
 - Class 300#
 - 304H stainless steel body
 - Extended bonnet w/heat dissipating fins
 - Purge and flush connections

- B**
 - 24"
 - 90%
 - Class 300#
 - Main transfer line valve with electric actuator
 - Mechanically linked to 8" 70% port



Proximity Switches

Logic Control Panel

Pacific offers panels to operate WEDGEPLUG™ isolation valves as well as the switch valve in delayed coker installation. Panels are hard-wired for single valve unit or PLC/DCS type for safe remote and sequential valve operation.



Proximity Switches

Two independent proximity switches designed for use with WEDGEPLUG™ in high temperature and dirty services such as delayed coker or asphalt production. Both mechanical trip switch and electronic inductive proximity switch are available for monitoring applications. These switches are mounted externally of the yoke for ease of installation, service and visual inspection. Switches are set to generate signals when the plug is fully seated in either fully open or closed positions. For even higher precision monitoring, a "Shadow Positioning" system is also available. Shadow Positioning system on WEDGEPLUG™ provides the ability to track both the vertical and angular positions of the plug (i.e., seated, un-seated and degree of opening of the valve).

Logic Control Panel





WEDGEPLUG™ Special Options

Protected, Double Seating

The plug is seated in the body seats when the valve is in both open and closed positions. This protects both body seats and the portion of the plug making seating contact from any abrasives in the line.

Special alloys must be used below -50°F. These valves are perfect performers for manifolding, chemical plants, airport fueling facilities, tanker service, refineries, and as pipeline block valves.

No Contamination

Since WEDGEPLUG™ valves do not require seal lubricants, they are suitable for such services as liquid and gaseous oxygen and nitrogen, food products, refined products, and various other chemicals where the presence of greases used for plug seal lubricants would contaminate the products and be harmful.

Fugitive Emission Testing

Packing tested with methane resulted in less than 100 ppm leakage.

Q-Plug

The Q-plug provides full port flow along with less weight and easier maintenance. Other enhancements include trunnion mounting to eliminate side loads for prolonged seat life; tangential purge; and heavy-duty mounting yoke design. The Q-plug is optional on certain sizes.



Q-Plug



* Dowtherm® is a registered trademark of Dow Chemical Company

Materials of Construction

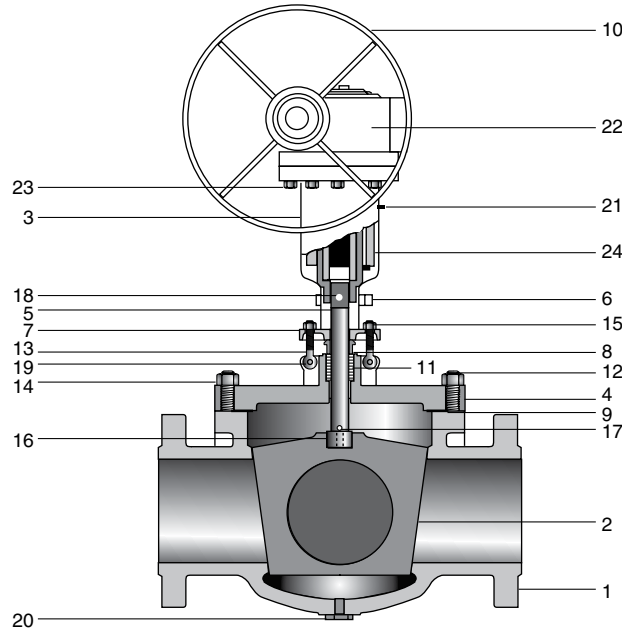

Note:
Pacific WEDGEPLUG™ intent is to show TYPICAL materials of construction. Materials are subject to change without notice and without obligations. Other material and combinations are available.

CARBON STEEL

ITEM	DESCRIPTION	ASTM SPEC
1	Body with optional hardfacing	A-216 Grade WCB
2	Plug (Hardened)	A-217 Grade CA15
3	Yoke	A-217 Grade C5
4	Bonnet	A-216 Grade WCB
5	Stem	A-276 Type 410
6	Position Indicator	Steel
7	Pkg. Gland Flg.	A-216 Grade WCB
8	Pkg. Gland	A-395 Ductile
9	Gasket Bonnet	Steel
10	Handwheel	Steel
11	*Packing	Graphoil®
12	Bonnet Stud	A-193 Grade B7
13	Eybolts	A-307 Grade A
14	Nut, Bonnet Stud	A-194 Grade 2H
15	Nut, Packing Gland Flange	A-563 Grade A
16	Plug Key	A-276 Type 410
17	Plug Key Retainer	A-276 Type 410
18	Keeper Pin, Indicator	Steel
19	Keeper Pin, Eyebolt	Steel
20	Pipe Plug	Carbon Steel
21	Lubricating Fitting	Steel
22	Gear Housing (AUMA)	
23	Cap Screw, Gear Housing	A-307 Grade A
24	Wedgetorque® Operator	

316 STAINLESS

ITEM	ASTM SPEC
1	A-351 Grade CF8M
2	A-351 Grade CF8M
3	A-217 Grade C5
4	A-351 Grade CF8M
5	A-276 Type 316
6	Steel
7	A-216 Grade WCB
8	A-395 Ductile
9	A-276 Type 316
10	Steel
11	Graphoil®
12	A-193 Grade B8M
13	A-307 Grade A
14	A-194 Grade 8M
15	A-563 Grade A
16	A-276 Type 316
17	A-276 Type 316
18	Steel
19	Steel
20	A-276 Type 316
21	Steel
22	
23	A-307 Grade A
24	

5Cr (A-217 C5)

ITEM	ASTM SPEC
1	A-217 Grade C5
2	A-217 Grade C5
3	A-217 Grade C5
4	A-217 Grade C5
5	A-276 Type 410
6	Steel
7	A-216 Grade WCB
8	A-395 Ductile
9	A-276 Type 410
10	Steel
11	Graphoil®
12	A-193 Grade B16
13	A-307 Grade A
14	A-194 Grade 4
15	A-563 Grade A
16	A-276 Type 410
17	A-276 Type 410
18	Steel
19	Steel
20	A-276 Type 410
21	Steel
22	
23	A-307 Grade A
24	

9Cr (A-217 C12)

ITEM	ASTM SPEC
1	A-217 Grade C12
2	A-217 Grade C12
3	A-217 Grade C5
4	A-217 Grade C12
5	A-276 Type 410
6	Steel
7	A-216 Grade WCB
8	A-395 Ductile
9	A-276 Type 410
10	Steel
11	Graphoil®
12	A-193 Grade B16
13	A-193 Grade B7
14	A-194 Grade 4
15	A-563 Grade A
16	A-276 Type 410
17	A-276 Type 410
18	Steel
19	Steel
20	A-276 Type 410
21	Steel
22	
23	A-307 Grade A
24	

* Standard packing is recommended for most applications to 850°F. However, in certain applications it may be necessary to use special high temperature packing. Please consult factory when ordering.



ASME Class 150 • 70% Port • Sizes 1 1/4" - 20"

- Refer to page 7 for Ordering Information
- Refer to page 16 for Materials of Construction
- Refer to page 12 for Tangential Purge Information

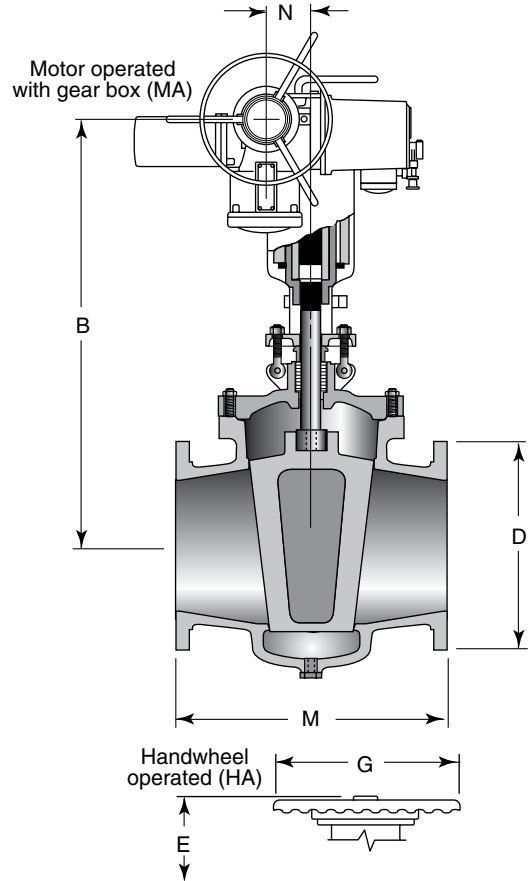
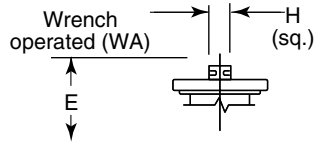
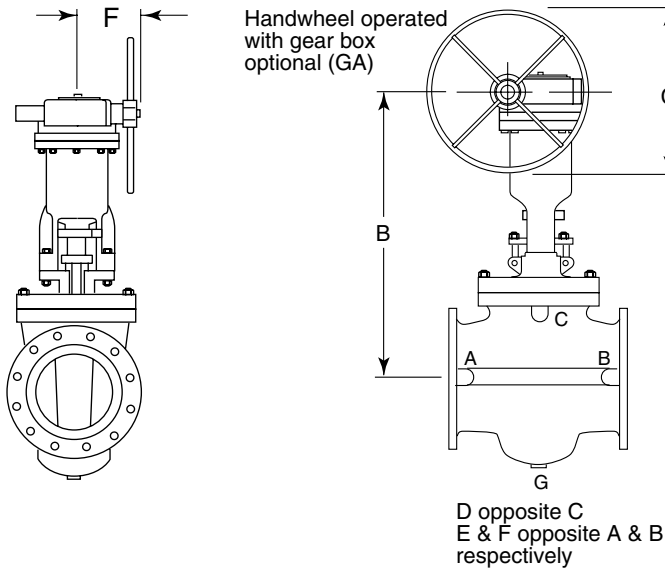

Dimensions, Weights & Flow Characteristics

Size	Wt.	B	C	D	E	F	G	H	N	M		K _v	C _t
										RF	RTJ		
1 1/4 (32)	58 (26)	N/A	N/A	4.63 (118)	15.25 (387)	N/A	9.00 (229)	1.25 (32)	N/A	7.50 (191)	8.00 (203)	.30 -	120
1 1/2 (40)	58 (26)	N/A	N/A	5.00 (127)	15.25 (387)	N/A	9.00 (229)	1.25 (32)	N/A	7.50 (191)	8.00 (203)	.21 -	146
2 (50)	70 (32)	N/A	N/A	6.00 (152)	15.75 (387)	N/A	9.00 (229)	1.25 (32)	N/A	7.00 (178)	7.50 (191)	.21 -	260
2 1/2 (65)	88 (40)	N/A	N/A	7.00 (178)	15.75 (387)	N/A	9.00 (229)	1.25 (32)	N/A	7.50 (191)	8.00 (203)	.27 -	360
3 (80)	135 (61)	18.63 (473)	12.00 (305)	7.50 (191)	16.00 (406)	6.50 (165)	14.00 (356)	1.25 (32)	2.50 (64)	8.00 (203)	8.50 (216)	.27 -	510
4 (100)	180 (81)	20.25 (514)	12.00 (305)	9.00 (229)	20.50 (521)	6.50 (165)	18.00 (457)	2.00 (51)	2.50 (64)	9.00 (229)	9.50 (241)	.30 -	870
6 (150)	270 (122)	21.25 (540)	12.00 (305)	11.00 (279)	21.25 (540)	6.50 (165)	18.00 (457)	2.00 (51)	2.50 (64)	10.50 (267)	11.00 (279)	.64 -	1350
8 (200)	430 (194)	29.50 (749)	16.00 (406)	13.50 (343)	N/A	6.70 (170)	N/A	N/A	3.20 (81)	11.50 (292)	12.00 (305)	.71 -	2270
10 (250)	530 (239)	32.83 (834)	16.00 (406)	16.00 (406)	N/A	6.70 (170)	N/A	N/A	4.00 (102)	13.00 (330)	13.50 (343)	1.03 -	2940
12 (300)	1100 (495)	34.63 (880)	16.00 (406)	19.00 (483)	N/A	6.70 (170)	N/A	N/A	4.00 (102)	24.00 (610)	24.50 (622)	.45 -	6415
14 (350)	1440 (648)	42.75 (1086)	24.00 (610)	21.00 (533)	N/A	10.00 (254)	N/A	N/A	4.92 (125)	27.00 (686)	27.50 (699)	.38 -	8570
16 (400)	2430 (1094)	46.25 (1175)	24.00 (610)	23.50 (597)	N/A	10.00 (254)	N/A	N/A	4.92 (125)	30.00 (762)	30.50 (775)	.39 -	11,140
18 (450)	2710 (1220)	47.00 (1194)	24.00 (610)	25.00 (635)	N/A	10.00 (254)	N/A	N/A	4.92 (125)	34.00 (864)	34.50 (876)	.40 -	14,090
20 (500)	2900 (1305)	47.00 (1194)	24.00 (610)	27.50 (699)	N/A	10.00 (254)	N/A	N/A	4.92 (125)	36.00 (914)	36.50 (927)	.41 -	17,240

ASME Class 300 • 70% Port • Sizes 1 1/4" - 20"

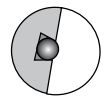
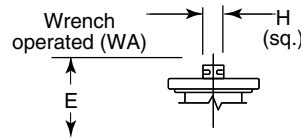
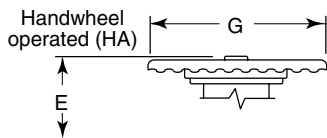
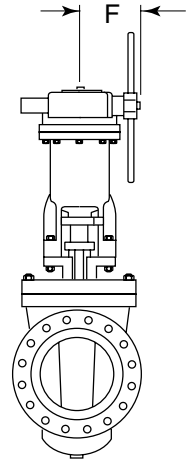
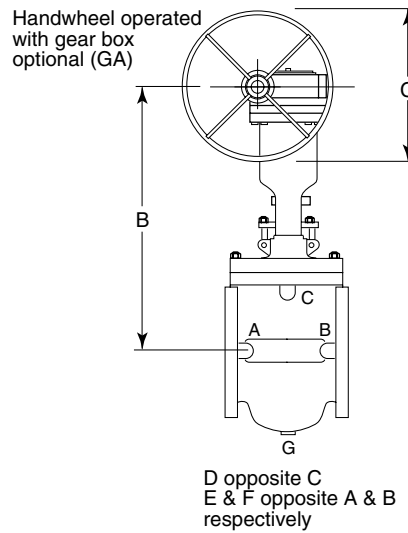
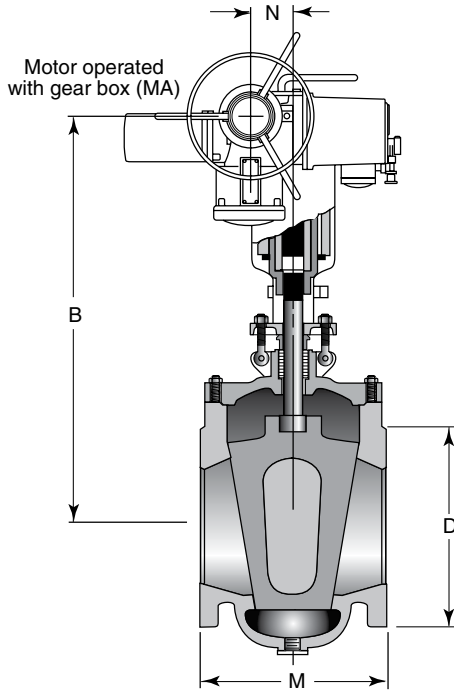

O-ring detail optional sizes 1/2" - 12"

Dimensions, Weights & Flow Characteristics

Size	Wt.	B	C	D	E	F	G	H	N	M		K _v	C _v
										RF	RTJ		
1 1/4 (32)	55 (25)	N/A	N/A	3.25 (83)	15.25 (387)	N/A	9.00 (229)	1.25 (32)	N/A	*6.62 (168)		.30 -	120
1 1/2 (40)	58 (26)	N/A	N/A	6.12 (155)	15.25 (387)	N/A	9.00 (229)	1.25 (32)	N/A	7.50 (191)	8.00 (203)	.20 -	150
2 (50)	70 (32)	N/A	N/A	6.50 (165)	15.75 (400)	N/A	9.00 (229)	1.25 (32)	N/A	8.50 (216)	9.12 (232)	.27 -	230
2 1/2 (65)	90 (41)	N/A	N/A	7.50 (191)	16.00 (406)	N/A	9.00 (229)	1.25 (32)	N/A	9.50 (241)	10.12 (257)	.22 -	400
3 (80)	150 (68)	18.75 (476)	12.00 (305)	8.25 (210)	16.00 (406)	6.50 (165)	14.00 (356)	1.25 (32)	2.50 (64)	11.12 (282)	11.75 (298)	.19 -	500
4 (100)	180 (81)	20.25 (514)	12.00 (305)	10.00 (254)	20.50 (521)	6.50 (165)	18.00 (457)	2.00 (51)	2.50 (64)	12.00 (305)	12.62 (321)	.21 -	1040
6 (150)	350 (158)	21.25 (540)	12.00 (305)	12.50 (318)	21.38 (543)	6.50 (165)	18.00 (457)	2.00 (51)	2.50 (64)	15.88 (403)	16.50 (419)	.27 -	2070
8 (200)	530 (239)	29.50 (749)	16.00 (406)	15.00 (381)	N/A	6.70 (170)	N/A	N/A	3.20 (81)	16.50 (419)	17.12 (435)	.34 -	3280
10 (250)	730 (329)	32.38 (822)	16.00 (406)	17.50 (445)	N/A	6.70 (170)	N/A	N/A	4.00 (102)	18.00 (457)	18.62 (473)	.41 -	4670
12 (300)	1390 (626)	43.00 (1092)	24.00 (610)	20.50 (521)	N/A	10.00 (254)	N/A	N/A	4.92 (125)	19.75 (502)	20.38 (518)	.79 -	4850
14 (350)	1800 (810)	42.75 (1086)	24.00 (610)	23.00 (584)	N/A	10.00 (254)	N/A	N/A	4.92 (125)	30.00 (762)	30.62 (778)	.32 -	10,360
16 (400)	2800 (1260)	46.25 (1175)	24.00 (610)	25.50 (648)	N/A	10.00 (254)	N/A	N/A	4.92 (125)	33.00 (838)	33.62 (854)	.34 -	13,130
18 (450)	3230 (1454)	47.00 (1194)	24.00 (610)	28.00 (711)	N/A	10.00 (254)	N/A	N/A	4.92 (125)	36.00 (914)	36.62 (930)	.34 -	16,610
20 (500)	3600 (1620)	47.00 (1194)	24.00 (610)	30.50 (775)	N/A	10.00 (254)	N/A	N/A	4.92 (125)	39.00 (991)	39.75 (1010)	.34 -	18,120

*Socket weld ends only.



ASME Class 150 • 90° Port • Sizes 6" - 24"

- Refer to page 7 for Ordering Information
- Refer to page 16 for Materials of Construction
- Refer to page 12 for Tangential Purge Information

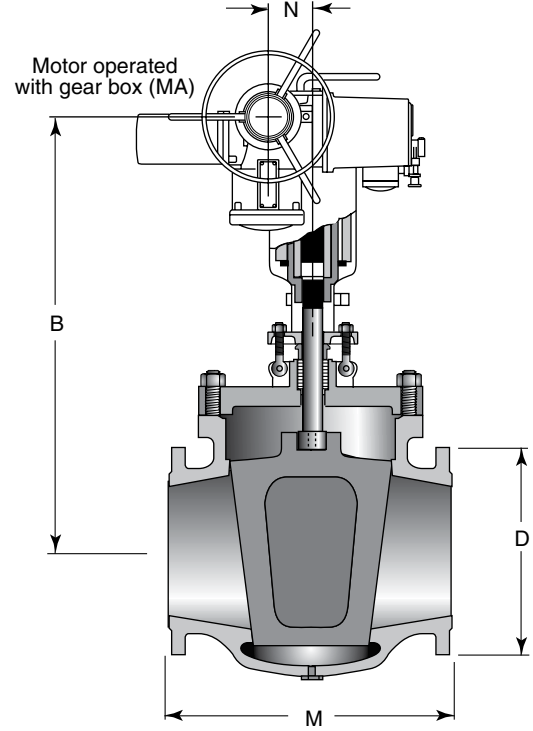
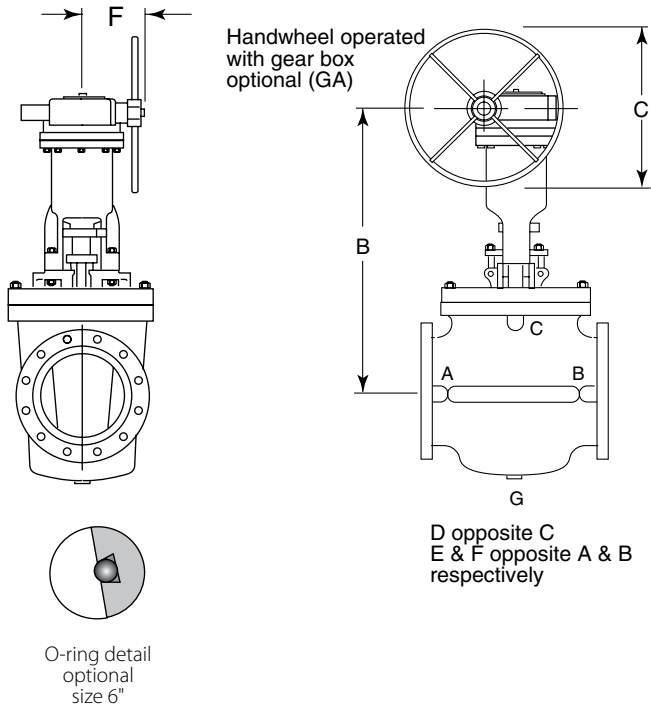

Dimensions, Weights & Flow Characteristics

Size	Wt.	B	C	D	F	N	M		K _v	C _v
							RF	RTJ		
6 (150)	345 (155)	29.50 (749)	16.00 (406)	11.00 (279)	6.70 (170)	3.20 (81)	15.50 (394)	16.00 (406)	.18 -	3200
8 (200)	446 (201)	30.25 (768)	16.00 (406)	13.50 (343)	6.70 (170)	3.20 (81)	18.00 (457)	18.50 (470)	.19 -	4,400
10 (254)	870 (392)	40.25 (1022)	24.00 (610)	17.50 (445)	10.00 (254)	4.92 (125)	18.00 (457)	18.62 (473)	.24 -	6,000
12 (304)	1600 (721)	42.00 (1066)	24.00 (610)	20.50 (521)	10.00 (254)	4.92 (125)	19.75 (502)	20.37 (517)	.16	10,500
14 (350)	1900 (855)	43.88 (1,115)	24.00 (610)	21.00 (533)	10.00 (254)	4.92 (125)	28.50 (724)	29.00 (737)	.17 -	12,610
24 (600)	6500 (2,925)	52.00 (1,321)	24.00 (610)	32.00 (812)	10.00 (254)	4.92 (125)	45.00 (1,143)	45.50 (1,156)	.16 -	40,120

ASME Class 300 • 90° Port • Sizes 6" - 30"

- Refer to page 7 for Ordering Information
- Refer to page 16 for Materials of Construction
- Refer to page 12 for Tangential Purge Information

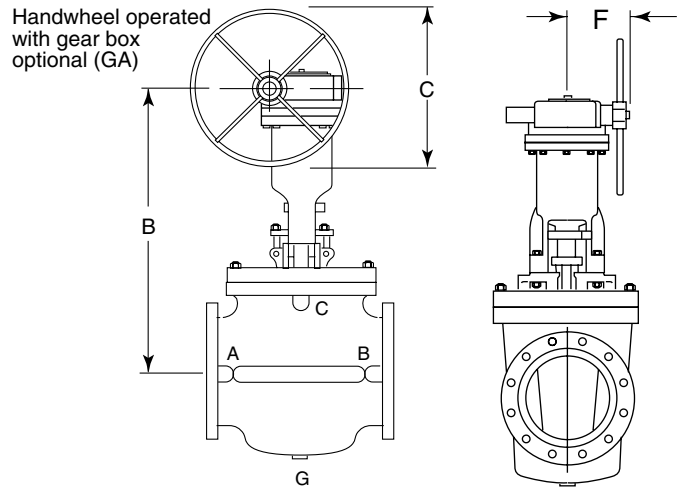
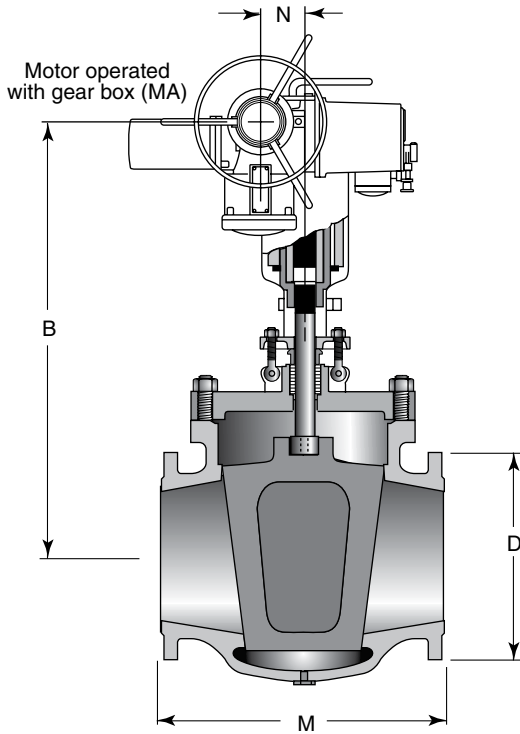

D opposite C
E & F opposite A & B respectively

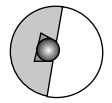

O-ring detail
optional
size 6"

Dimensions, Weights & Flow Characteristics

Size	Wt.	B	C	D	F	N	M		K _v	C _v
							RF	RTJ		
6 (150)	370 (167)	29.50 (749)	16.00 (406)	12.50 (318)	6.70 (170)	3.20 (81)	15.88 (403)	16.50 (419)	.18 -	2550
8 (200)	600 (270)	30.25 (768)	16.00 (406)	15.00 (381)	6.70 (170)	3.20 (81)	16.50 (419)	17.12 (435)	.24 -	3900
10 (250)	870 (390)	40.25 (1,022)	24.00 (610)	17.50 (445)	10.00 (254)	4.92 (125)	18.00 (457)	18.62 (473)	.24 -	6000
12 (300)	1600 (727)	42.00 (1,067)	24.00 (610)	20.50 (521)	10.00 (254)	4.92 (125)	19.75 (502)	20.37 (517)	.16 -	10,500
14 (350)	1950 (878)	44.00 (1,118)	24.00 (610)	23.00 (584)	10.00 (254)	4.92 (125)	30.00 (762)	30.62 (778)	.17 -	12,610
16 (400)	3000 (1,350)	45.25 (1,149)	24.00 (610)	25.50 (648)	10.00 (254)	4.92 (125)	33.00 (838)	33.62 (854)	.17 -	16,770
18 (450)	3350 (1,508)	46.25 (1,175)	24.00 (610)	28.00 (711)	10.00 (254)	4.92 (125)	36.00 (914)	36.62 (930)	.16 -	21,620
20 (500)	4400 (1,980)	47.25 (1,200)	24.00 (610)	30.50 (775)	10.00 (254)	4.92 (125)	39.00 (991)	39.75 (1,010)	.16 -	27,000
24 (600)	6600 (2,970)	52.00 (1,321)	24.00 (610)	36.00 (914)	10.00 (254)	4.92 (125)	45.00 (1,143)	45.88 (1,165)	.16 -	40,120
30 (750)	10700 (4,853)	62.75 (1,594)	36.00 (914)	43.00 (1092)	22.00 (559)	7.88 (200)	55.00 (1,397)	56.00 (1,422)	.21 -	55,000



ASME Class 300 • 100% Port • Sizes 1/2" - 14"

- Refer to page 7 for Ordering Information
- Refer to page 16 for Materials of Construction
- Refer to page 12 for Tangential Purge Information

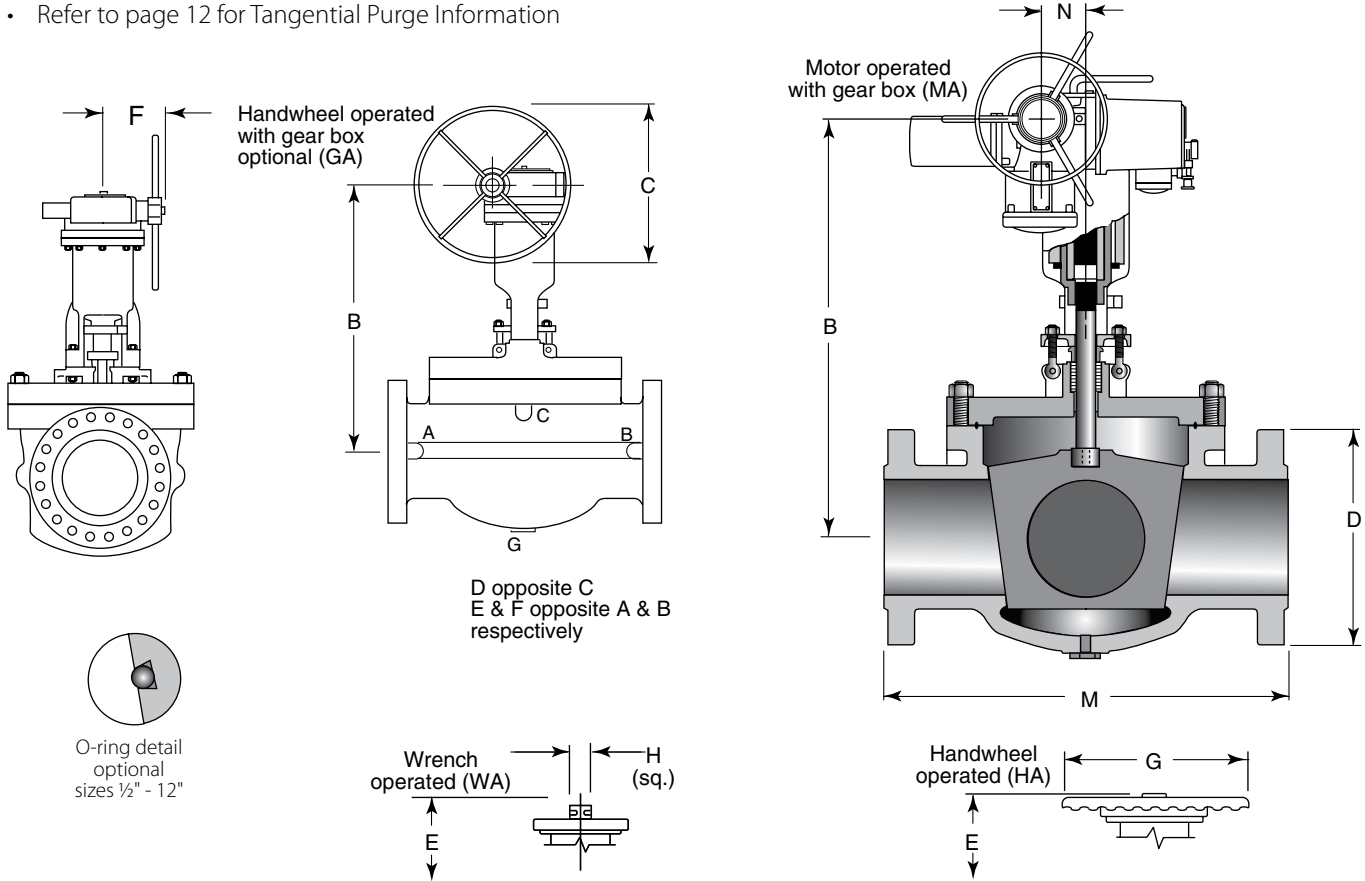

Dimensions, Weights & Flow Characteristics

Size	Wt.	B	C	D	E	F	G	H	N	M		K _v	C _v
										RF	RTJ		
1/2 (15)	35 (16)	N/A	N/A	3.75 (95)	15.00 (381)	N/A	9.00 (229)	1.25 (32)	N/A	*7.50 (191)	-	.30 -	14
3/4 (20)	45 (20)	N/A	N/A	4.62 (117)	15.00 (381)	N/A	9.00 (229)	1.25 (32)	N/A	*7.50 (191)	-	.18 -	.18
1 (25)	58 (26)	N/A	N/A	4.88 (124)	15.00 (381)	N/A	9.00 (229)	1.25 (32)	N/A	7.50 (191)	8.00 (203)	.17 -	72
1 1/2 (40)	68 (31)	N/A	N/A	6.12 (155)	15.00 (381)	N/A	9.00 (229)	1.25 (32)	N/A	9.50 (241)	10.00 (254)	.13 -	184
2 (50)	160 (72)	19.50 (495)	12.00 (305)	6.50 (165)	19.03 (483)	6.50 (165)	18.00 (457)	2.00 (51)	2.50 (64)	11.12 (282)	11.75 (298)	.11 -	368
2 1/2 (65)	175 (79)	19.00 (483)	12.00 (305)	7.50 (191)	19.12 (486)	6.50 (165)	18.00 (457)	2.00 (51)	2.50 (64)	13.00 (330)	13.62 (346)	.09 -	610
3 (80)	225 (101)	19.50 (495)	12.00 (305)	8.25 (210)	18.50 (470)	6.50 (165)	18.00 (457)	2.00 (51)	2.50 (64)	15.25 (387)	15.88 (403)	.09 -	890
4 (100)	390 (176)	21.50 (546)	12.00 (305)	10.00 (254)	21.63 (549)	6.50 (165)	18.00 (457)	2.00 (51)	2.50 (64)	18.00 (457)	18.62 (473)	.08 -	1730
6 (150)	800 (360)	29.50 (749)	16.00 (406)	12.50 (318)	N/A	6.70 (170)	N/A	N/A	3.20 (81)	22.00 (559)	22.62 (575)	.06 -	4950
8 (200)	1290 (581)	40.38 (1,026)	24.00 (610)	15.00 (381)	N/A	10.00 (254)	N/A	N/A	4.92 (125)	27.00 (686)	27.62 (702)	.05 -	8800
10 (250)	2100 (945)	42.38 (1,076)	24.00 (610)	17.50 (445)	N/A	10.00 (254)	N/A	N/A	4.92 (125)	32.50 (826)	33.12 (841)	.05 -	14,020
12 (300)	2590 (1,166)	40.38 (1,026)	24.00 (610)	20.50 (521)	N/A	10.00 (254)	N/A	N/A	4.92 (125)	38.00 (965)	38.62 (981)	.04 -	21,220
14 (350)	3490 (1,571)	43.50 (1,105)	24.00 (610)	23.00 (584)	N/A	10.00 (254)	N/A	N/A	4.92 (125)	40.00 (1,016)	40.62 (1,032)	.04 -	26,600

*Threaded or socket ends only.

ASME Class 300 • 100% Port • Sizes 14" - 30" (Long and Short)

- Refer to page 7 for Ordering Information
- Refer to page 16 for Materials of Construction
- Refer to page 12 for Tangential Purge Information

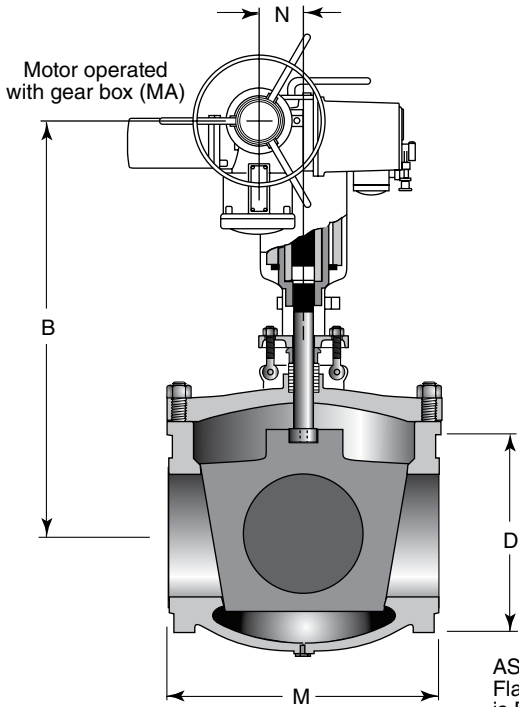

ASME Class 300 Flange Bolt Circle is Drilled and Tapped

Long Pattern

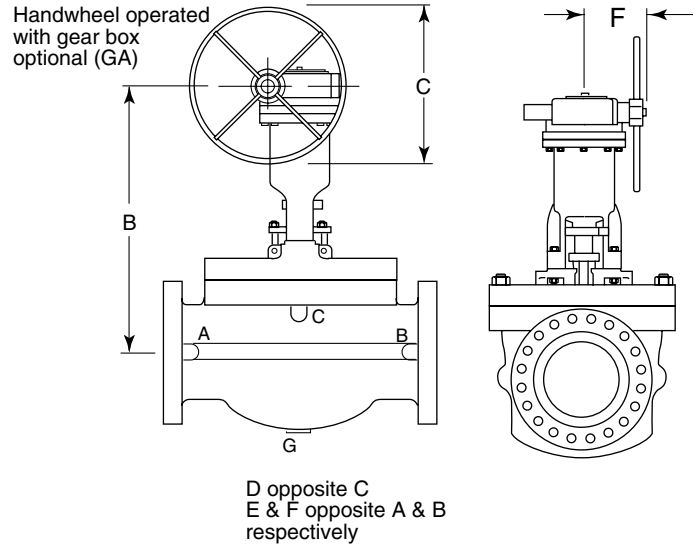

Short Pattern

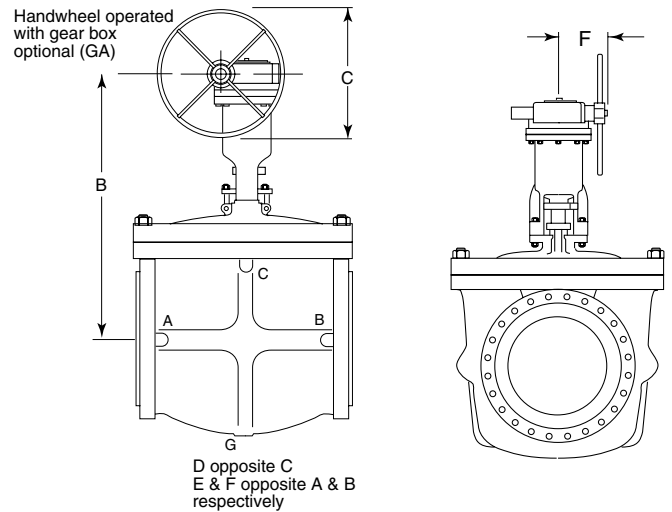

Dimensions, Weights & Flow Characteristics

Size	Wt.	B	C	D	F	N	M		K _v	C _v
							RF	RTJ		
14 (350)	3490 (1,571)	43.50 (1,105)	24.00 (610)	23.00 (584)	10.00 (254)	4.92 (125)	30.00 (762)	30.62 (778)	.029 -	30,900
16 (400)	4500 (2,025)	47.25 (1,194)	24.00 (610)	25.50 (648)	10.00 (254)	4.92 (125)	33.00 (838)	33.62 (854)	.028 -	41,500
18 (450)	5025 (2,261)	48.50 (1,232)	24.00 (610)	28.00 (711)	10.00 (254)	4.92 (125)	36.00 (914)	36.62 (930)	.025 -	56,200
20 (500)	7100 (3,195)	50.00 (1,270)	24.00 (610)	30.50 (775)	10.00 (254)	4.92 (125)	39.00 (991)	39.75 (1,010)	.024 -	71,060
20 long (500)	7250 (3,263)	50.00 (1,270)	24.00 (610)	30.50 (775)	10.00 (254)	4.92 (125)	50.00 (1270)	51.00 (1,295)	.024 -	71,060
24 (600)	9700 (4,365)	51.50 (1,308)	24.00 (610)	36.00 (914)	10.00 (254)	4.92 (125)	45.00 (1,143)	45.88 (1,165)	.024 -	100,500
24 long (600)	9850 (4,433)	51.50 (1,308)	24.00 (610)	36.00 (914)	10.00 (254)	4.92 (125)	53.38 (1,356)	54.25 (1,378)	.024 -	100,500
30 (750)	16900 (7,605)	65.00 (1,651)	36.00 (915)	43.00 (1,092)	22.00 (559)	7.88 (200)	55.00 (1,397)	56.00 (1,422)	.020 -	174,100



ASME Class 600 • 100% Port • Sizes 1/2" - 14"

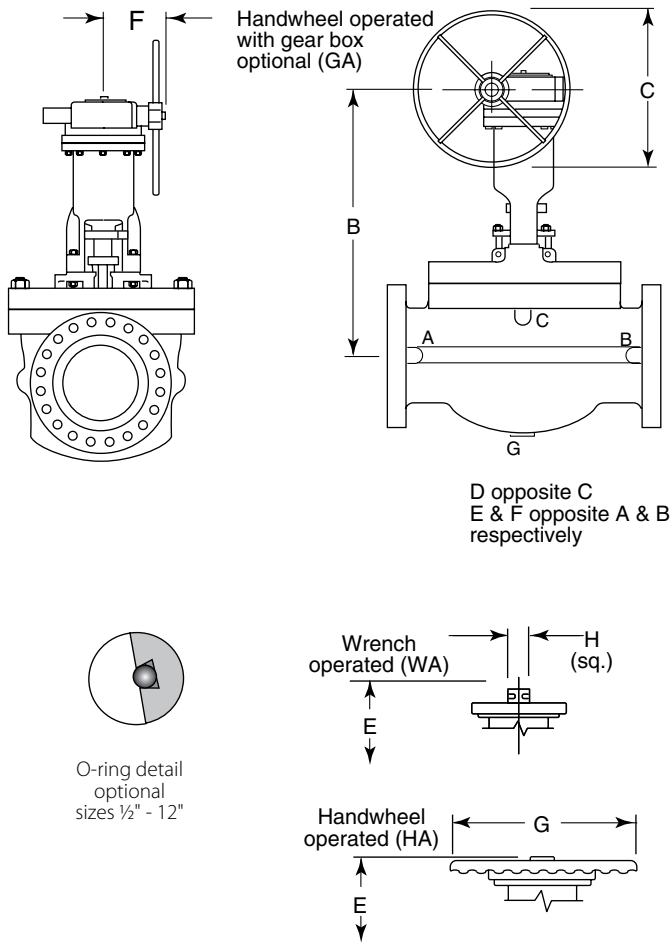

- Refer to page 7 for Ordering Information
- Refer to page 16 for Materials of Construction
- Refer to page 12 for Tangential Purge Information

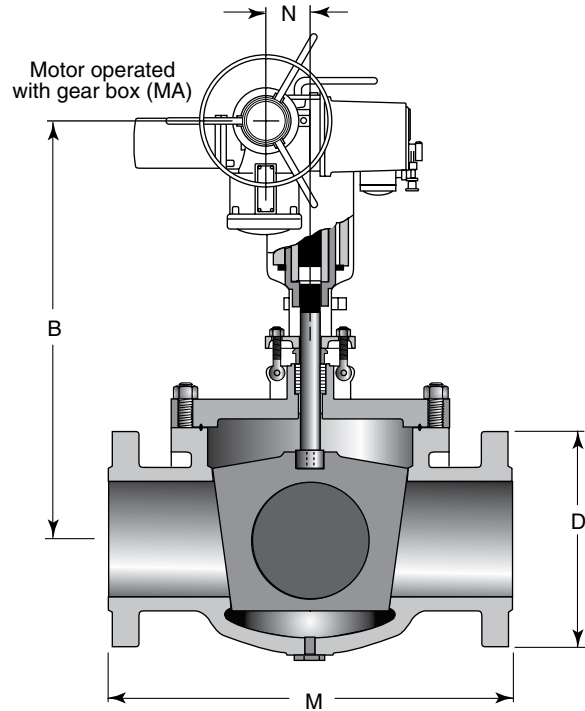

Dimensions, Weights & Flow Characteristics

Size	Wt.	B	C	D	E	F	G	H	N	M		K _v	C _v
										RF	RTJ		
1/2 (15)	50 (23)	N/A	N/A	2.25 (57)	15.00 (381)	N/A	9.00 (229)	1.25 (32)	N/A	*5.50 (140)	-	.30 -	14
3/4 (20)	55 (45)	N/A	N/A	2.25 (57)	15.00 (381)	N/A	9.00 (229)	1.25 (32)	N/A	*5.50 (140)	-	.18 -	39
1 (25)	60 (27)	N/A	N/A	4.88 (124)	15.00 (381)	N/A	9.00 (229)	1.25 (32)	N/A	10.00 (254)	10.00 (254)	.23 -	62
1 1/2 (40)	80 (36)	N/A	N/A	6.12 (155)	15.00 (381)	N/A	9.00 (229)	1.25 (32)	N/A	12.50 (318)	12.50 (318)	.18 -	160
2 (50)	190 (86)	19.50 (495)	12.00 (305)	6.50 (165)	19.50 (495)	6.50 (165)	18.00 (457)	2.00 (51)	2.50 (64)	13.00 (330)	13.12 (333)	.12 -	340
2 1/2 (65)	240 (108)	19.25 (489)	12.00 (305)	7.50 (191)	19.00 (483)	6.50 (165)	18.00 (457)	2.00 (51)	2.50 (64)	13.00 (330)	13.12 (333)	.09 -	610
3 (80)	300 (135)	19.50 (495)	12.00 (305)	8.25 (210)	19.50 (495)	6.50 (165)	18.00 (457)	2.00 (51)	2.50 (64)	17.50 (445)	17.62 (448)	.11 -	830
4 (100)	490 (221)	21.50 (546)	12.00 (305)	10.75 (273)	21.50 (546)	6.50 (165)	18.00 (457)	2.00 (51)	2.50 (64)	20.00 (508)	20.12 (511)	.09 -	1640
6 (150)	1050 (473)	30.33 (770)	16.00 (406)	14.00 (356)	N/A	6.70 (170)	N/A	N/A	4.00 (102)	26.00 (660)	26.12 (663)	.07 -	4220
8 (200)	1600 (720)	40.25 (1,022)	24.00 (610)	16.50 (419)	N/A	10.00 (254)	N/A	N/A	4.92 (125)	31.25 (794)	31.38 (797)	.05 -	8180
10 (250)	2875 (1,294)	42.25 (1,073)	24.00 (610)	20.00 (508)	N/A	10.00 (254)	N/A	N/A	4.92 (125)	37.00 (940)	37.12 (943)	.05 -	13,340
12 (300)	3250 (1,463)	41.25 (1,048)	24.00 (610)	22.00 (559)	N/A	10.00 (254)	N/A	N/A	4.92 (125)	42.00 (1,067)	42.12 (1,070)	.05 -	17,520
14 (356)	4300 (1,937)	43.50 (1,105)	24.00 (610)	23.75 (603)	N/A	10.00 (254)	N/A	N/A	4.92 (125)	48.00 (1,219)	48.12 (1,222)	.05 -	22,500

*Threaded or socket ends only.

ASME Class 900 • 100% Port • Sizes 1/2" - 12"

- Refer to page 7 for Ordering Information
- Refer to page 16 for Materials of Construction
- Refer to page 12 for Tangential Purge Information

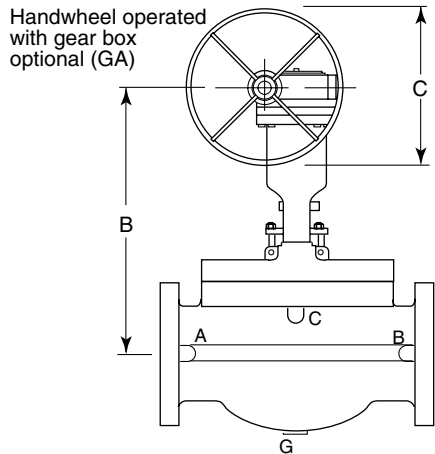

D opposite C
E & F opposite A & B respectively

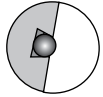

O-ring detail optional sizes 1/2" - 12"

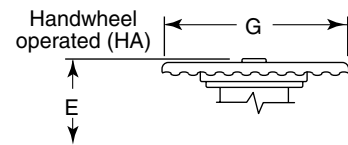
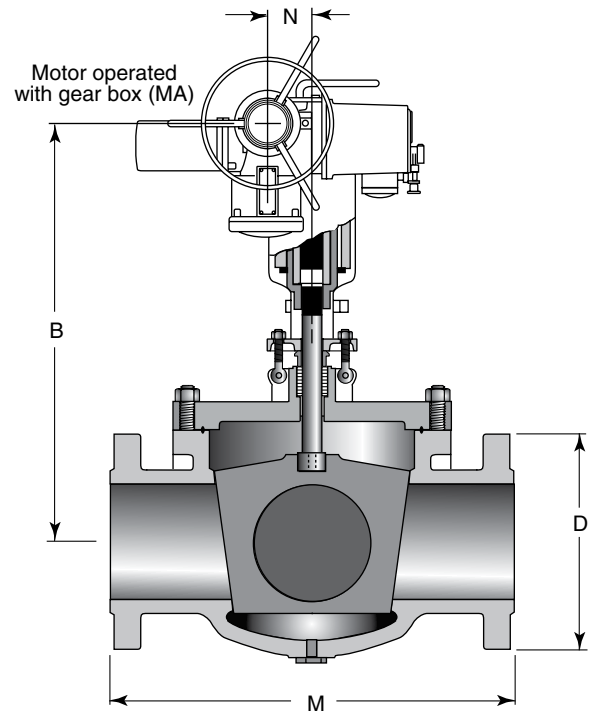
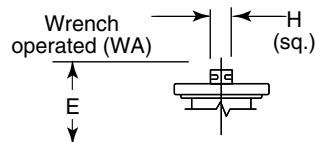

Dimensions, Weights & Flow Characteristics

Size	Wt.	B	C	D	E	F	G	H	N	M		K _v	C _v
										RF	RTJ		
1/2 (15)	48 (22)	N/A	N/A	4.75 (121)	15.00 (381)	N/A	9.00 (229)	1.25 (32)	N/A	*10.00 (254)	-	.55 -	10
3/4 (20)	57 (26)	N/A	N/A	5.12 (130)	15.00 (381)	N/A	9.00 (229)	1.25 (32)	N/A	*10.00 (254)	-	.33 -	30
1 (100)	68 (31)	N/A	N/A	5.88 (149)	15.00 (381)	N/A	9.00 (229)	1.25 (32)	N/A	10.00 (254)	10.00 (254)	.23 -	62
1 1/2 (150)	92 (41)	N/A	N/A	7.00 (179)	15.00 (381)	N/A	9.00 (229)	1.25 (32)	N/A	12.00 (305)	12.00 (305)	.17 -	164
2 (50)	208 (94)	20.50 (521)	12.00 (305)	8.50 (216)	19.50 (495)	6.50 (165)	18.00 (457)	2.00 (51)	2.50 (64)	14.50 (368)	14.62 (371)	.14 -	322
2 1/2 (65)	350 (158)	22.00 (559)	12.00 (305)	9.62 (244)	19.00 (483)	6.50 (165)	18.00 (457)	2.00 (51)	2.50 (64)	16.50 (419)	16.62 (422)	.13 -	417
3 (80)	360 (162)	19.50 (495)	12.00 (305)	9.50 (241)	19.50 (495)	6.50 (165)	18.00 (457)	2.00 (51)	2.50 (64)	18.50 (470)	18.62 (473)	.11 -	808
4 (100)	560 (252)	20.50 (521)	12.00 (305)	11.50 (292)	21.50 (546)	6.50 (165)	18.00 (457)	2.00 (51)	2.50 (64)	22.00 (559)	22.12 (562)	.09 -	1570
6 (150)	1200 (540)	29.50 (749)	16.00 (406)	15.00 (381)	N/A	6.70 (170)	N/A	N/A	4.00 (102)	29.00 (737)	29.12 (740)	.07 -	4000
8 (200)	2200 (990)	40.25 (1,022)	24.00 (610)	18.50 (470)	N/A	10.00 (254)	N/A	N/A	4.92 (125)	32.00 (813)	32.12 (816)	.05 -	7230
10 (250)	3350 (1,508)	43.50 (1,105)	24.00 (610)	21.50 (546)	N/A	10.00 (254)	N/A	N/A	4.92 (125)	38.00 (965)	38.12 (968)	.05 -	13,160
12 (300)	5000 (2,250)	44.50 (1,030)	24.00 (610)	24.00 (610)	N/A	10.00 (254)	N/A	N/A	4.92 (125)	44.00 (1,118)	44.12 (1,121)	.05 -	16,301

*Threaded or socket ends only.



ASME Class 1500 • Trunnion Type

- Refer to page 7 for Ordering Information
- Refer to page 16 for Materials of Construction
- Refer to page 12 for Tangential Purge Information
- Special Trunnion sizes and configurations are available. Consult factory when ordering.

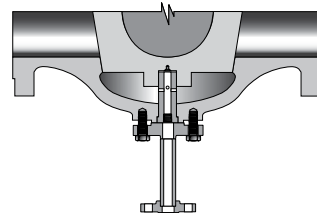
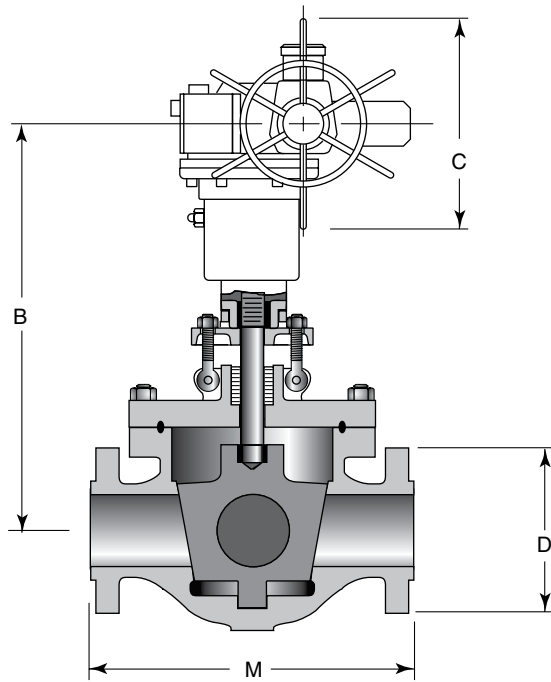

Trunnion

Has the ability to purge through the trunnion to keep both the trunnion and the cavity clean.

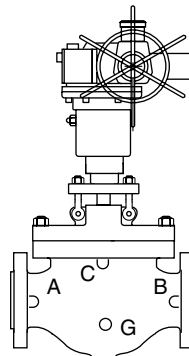

Valve not drilled for purge ports

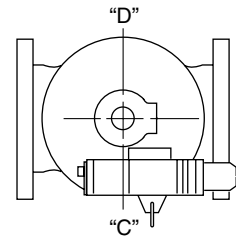

Top View

Dimensions & Weights

Size	Est. Wt.	B	C	D	M		K _v	C _v
					RF	RTJ		
6 (150)	1850 (833)	41.25 (1,048)	24.00 (610)	15.50 (394)	27.75 (705)	30.00 (762)	.07 -	3100

CRANE[®]

CRANE CHEMPHARMA & ENERGY

4526 Research Forest Drive,
Suite 400
The Woodlands
Texas 77381, U.S.A.
Tel: +1 936 271 6500

Xomox Chihuahua, S.A.

Juan Ruiz de Alarcón 313,
Complejo Industrial Chihuahua,
31136 Chihuahua
Mexico
Tel: +52 614 442 9860

Crane Company, and its subsidiaries cannot accept responsibility for possible errors in catalogues, brochures, other printed materials, and website information. Crane Company reserves the right to alter its products without notice, including products already on order provided that such alteration can be made without changes being necessary in specifications already agreed. All trademarks in this material are the property of the Crane Company or its subsidiaries. The Crane and Crane brands logotype (ALOYCO[®], BAUM[®], CENTER LINE[®], CRANE[®], CRYOFLO[®], DEPA[®] & ELRO[®], DOPAK[®], DUO-CHEK[®], FLOWSEAL[®], GYROLOK[®], GO REGULATOR[®], HOKE[®], JENKINS[®], KROMBACH[®], NOZ-CHEK[®], PACIFIC VALVES[®], RESISTOFLEX[®], REVO[®], SAUNDERS[®], STOCKHAM[®], TEXAS SAMPLING[®], WESTLOCK CONTROLS[®], WTA[®], and XOMOX[®]) are registered trademarks of Crane Co. All rights reserved.