



PACIFIC VALVES

WEDGEPLUG

OPERATION AND MAINTENANCE MANUAL

PROVEN PERFORMANCE IN THE MOST SEVERE SERVICE APPLICATIONS

WEDGEPLUG™
METAL SEATED VALVES
FROM PACIFIC VALVES®

CRANE



www.cranecpe.com



Table of Content

General Valve Operation & Maintenance	3-8
WEDGEPLUG™ Valves	9
Bolting Torques	10-11
Long Term Storage	12
Valve Installation	13-15
Packing & Gasket Maintenance and Valve Lubrication	16-19
Gear and Motor Operators	20-21
Warnings	22-24

General Valve Operation & Maintenance

1.0 Theory of operation

WEDGEPLUG™ valves are highly specialized non-lubricated plug valves, which operate as both a quarter turn and rising stem valve. WEDGEPLUG™ valves are designed to close off or open up the flow in a pipeline. The WEDGEPLUG™ is designed to completely stop flow and form a tight seal against pressure in either direction. WEDGEPLUG™ valves are not recommended for throttling use.

2.0 Description

This manual covers all WEDGEPLUG™ Metal Seated Valves from PACIFIC VALVES®. These valves are designed within the limits of ASME B16.34. For the operator and mounting topworks of these valves, the user is referred to pages 20-21 in this manual. See paragraph 5.0 for operation of valves. This manual is for reference purposes only. Disassembly and maintenance of valves should only be performed by qualified personnel. Consult PACIFIC VALVES® for specific technical support.

3.0 Installation

When unpacking, care should be exercised in lifting and handling to avoid damage to valves or injury to personnel. Do not lift any valve by the handwheel or stem. Use lifting lugs or straps around the valve body. For specific installation information, please refer to page 13-15 of this manual. When installing, ensure that all foreign material is removed from the interior of the valve, including desiccants.

Note: Do not remove protective end coverings until immediately prior to valve installation.

Note: Do not disassemble or modify a Pacific Valve in any way prior to installation. This will void the factory warranty if it occurs. A protective paint has been applied to the weld ends on some valves and it should be removed before welding.

For soft-seated valves, the temperature of the valve body should not exceed 200°F during welding to avoid damaging the soft seals. Check the temperature of surrounding areas to avoid heating valve body excessively, especially with small sizes, where a heat sink may be necessary.

Use the smallest electrodes and the minimum amperage possible consistent with approved welding procedures. This will help to minimize warpage in the seat areas. Tack welds should be ground out before completing the root pass in that area.

Valves of carbon steel should be allowed to cool slowly. The valve may be covered with a heat-insulating blanket to promote slow cooling and limit the heat-affected zone. Appropriate industry standards should be followed for all PWHT.

Note: Ensure that all foreign material (dirt, weld slag, etc.) has been removed from the valve prior to and after installation. Foreign material is the primary cause of premature seat failures.

4.0 Warranty

All PACIFIC VALVES® are backed by a full manufacturer's warranty against defects in materials or workmanship. It should be noted that any work or modification performed on a Pacific Valve must be authorized by PACIFIC VALVES® to retain the original factory warranty.

5.0 Operating instructions

PACIFIC VALVES® are designed for simplicity and ease of operation. To open a WEDGEPLUG™, turn the handwheel in a counterclockwise direction; continue turning until interference is felt; at this point, the valve will be fully open. On WEDGEPLUG™ valves it is imperative to verify that the position indicator has lowered into the final seating position.

With some larger valves under conditions of high pressure, a rim pull of more than 250 lbs. may be required to achieve proper seating.

Caution! - These valves were designed to operate within the pressure and temperature limits of ASME B16.34. Do not exceed these limits.



General Valve Operation & Maintenance

6.0 Maintenance

6.1 Preventative Maintenance and Periodic Inspection

PACIFIC VALVES® recommends that periodic inspections be made of all valves. The frequency of these inspections will vary, depending upon the severity of service and frequency of operation of the valve. As a minimum, all valves should be checked quarterly to ensure proper operation and discourage the damage compounding effects of leakage. The following list details the areas requiring inspection and maintenance.

Item to inspect	WEDGEPLUG™
Check Stem threads for wear	XXX
Check for Packing leaks	XXX
Check body/bonnet joint for leaks, retighten all bolting (a)	XXX
If conditions permit, operate valve.	XXX
Inspect all external connections	XXX
Ensure Stem and seal areas are free from debris	XXX
Check all lubrication points	XXX
Inspect condition of motor and/or gear operators (when used)	XXX
Inspect valve for obvious damage	XXX

6.2 Maintenance of valve under pressure

If the above listed inspections reveal any indications, the following procedures are recommended:

Note: Extreme care should be taken when working on any pressurized system!

6.2.1

If the stem packing is leaking, the eyebolt nuts on the gland flange should be tightened uniformly until the leakage stops. If the leakage continues or there is no adjustment remaining, additional packing must be installed or the packing must be replaced. (See disassembly procedure for appropriate valve or packing and gasket maintenance page 16). It should also be noted that the valve should be able to operate freely at all times. If the valve cannot operate due to excessive packing force, the packing has become worn and must be replaced at first opportunity.

6.2.2

The stem threads that are exposed to atmosphere should be periodically lubricated to reduce wear, operating torque, and

to deter corrosion. Care should be taken to ensure that only the threaded portion of the stem is lubricated. PACIFIC VALVES® does not recommend the practice of lubricating the sealing area of the stem. This practice tends to attract debris and foreign material, which can lead to stem or stuffing box damage.

6.2.3

The yoke sleeve should be lubricated periodically through the grease fittings to ensure smooth operation. Lubrication should be inspected and revised at each application. Each installation may have specific requirements/ specifications regarding lubrication.

6.2.4

If leakage develops at the body/bonnet joint of a bolted bonnet valve, the bonnet stud nuts should be tightened uniformly. This tightening should be done in accordance with the bolting torque page 10 of this manual.

Caution! Do not overstress the bolting. If leakage continues, the gasket should be replaced. (See the bolting torque page 10 or the appropriate valve disassembly procedure).

6.2.5

If normal inspection reveals a binding or galling action of valve operating parts, it is advisable to dismantle and inspect the valve parts at the first opportunity. Contact PACIFIC VALVES® prior to disassembling any valve.

7.0 Identification

All PACIFIC VALVES® are identified with a metal tag that is riveted to the valve. This tag is usually found on the body/bonnet joint area, or on the top plate area near the handwheel. When performing any work, ordering spare parts, or requesting technical support, please refer to this tag. The Serial number (6), Figure number (11) and Stock number (7) are the keys to proper valve identification.

General Valve Operation & Maintenance

Explanation of tag markings

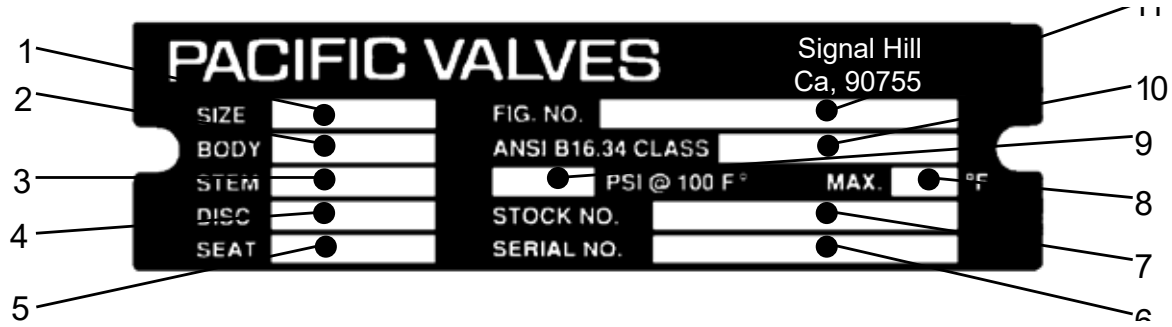

1	SIZE	Nominal pipe size (NPS) of the valve
2	BODY	Body ASTM material grade designation
3	STEM	Stem material
4	DISC	Disc or Wedge trim material
5	SEAT	Seat trim material
6	SERIAL NO.	Unique number identifying a single valve
7	STOCK NO	Number identifying a group of like valves
8	MAX °F	Maximum temperature at which the valve may be operated within the limits of pressure allowed by ASME B16.34, Table 2.
9	PSI @ 100 °F	Pressure in psig at which the valve is rated to operate when the temperature does not exceed 100 °F
10	ANSI B16.34 CLASS	Pressure class rating of the valve as defined in ASME B16.34 Section 2.
11	FIG. NO.	Number identifying the valve's main features including material, class, trim, end connections, and operator type. See the following sections for classification of Figure Numbers.



General Valve Operation & Maintenance

Following is the figure number definition for WEDGEPLUG™ Metal Seated Valves from PACIFIC VALVES®:

G	A	O	6	OR	RF
1	2	3	4	5	6
TYPE OF OPERATOR	PLUG/STEM ARRANGEMENT	PORT OPENING	PRESSURE CLASS	OPTIONAL FEATURES	END CONNECTIONS

1	Type of Operator	W Wrench H Handwheel G Gear M Motor (Electric or Air) C Cylinder (Air or Hydraulic)
2	Plug and Stem Arrangement	A Standard Design B Balanced Stem T Trunnion Mounted
3	Port Opening	4 40% 7 70% 9 90% 0 100%
4	Pressure Class	1 150 3 300 6 600 8 900 9 1500
5	Optional Features	OR O-Seal EB Extended Bonnet HD Heat dissipating Fins S Standard steam jacket J Steam jacket with oversized flanges and long face to face. Z Flangeless Design ¾ No optional features T3 Pipeline Standard Trim T6 Pipeline NACE Standard T7 Pipeline NACE (Highly Corrosive) XX Other Pipeline Trims upon application
6	End Connections	RF Raised face RJ Ring Joint FF Flat face SF Special serrated finish BW Butt weld SE Screwed ends SW Socket weld ends GH Grayloc® Hub

General Valve Operation & Maintenance

Boundary conditions for WEDGEPLUG™ products

Scope of product:	½" through 30" Class 150 through 1500
Service fluid:	Water, steam, gas, or hydrocarbon compounds.
Service Life:	20 years or when corrosion allowance is depleted whichever is less. This excludes normal maintenance parts such as packing, seals, gaskets and parts that move relative to each other e.g. seats, stems and bushings.
Allowable pressure and temperature:	ASME B16.34
Materials for pressurized parts:	Only materials approved under PMA by Accredited Notified Body may be used. See approved CE materials list. Appropriate material for service conditions to be based upon the following criteria: <ol style="list-style-type: none"> 1. The design pressure and temperature 2. An acceptable service life consistent with the corrosion rate of the material at design conditions. 3. Expected operating conditions within the defined pressure cycles, thermal cycles and flow velocity limits.
Packing and gasket materials	To be compatible with expected operating conditions
Corrosion/erosion allowance:	Varies by valve size and pressure class. See valve wall thickness calculation in ASME 16.34.
Method of operation:	Wrench, Handwheel, Manual Gear, or Motor Actuator
Installation orientation:	Stem vertical in a horizontal pipe run.
Flow velocity.	To keep noise and erosion at or below reasonable levels, valves are not to be used for throttling service and velocity is not to exceed $120 \sqrt{V}$ Where \sqrt{V} = Specific volume of flowing medium
Hydrostatic test:	1.5 times the 100 °F rating pressure in ASME B16.34 for the body material
Pressure and Thermal Cycles:	Unlimited cycles < Design Pressure/3 & 30°F
Heat up/cool down rate:	Not to exceed 100 °F per hour for 2000 cycles
Pipe & support reactions:	All reaction loads transmitted through valve ends. Cross section and Moment of Inertia of valve ends to be greater than that of the connecting pipe.
External fire capability:	Valve seats of standard product may be solid metal or may contain plastic inserts. Solid metal seats are not suitable for a sustained external heat source greater than 1500 °F. Plastic inserted seats are not suitable for temperatures greater than 450 °F.
Wind and Earthquake rating:	1 g load in any direction.
Vent or Drain method	None



General Valve Operation & Maintenance

Minimum Wall Thickness For All Products By Pressure Class & Corrosion Allowance

Size (In)	Class 150	Class 300	Class 600	Class 900	Class 1500	Class 2500	Corrosion Allowance
0.5	0.11	0.11	0.13	0.16	0.19	0.25	0.12
0.75	0.12	0.12	0.13	0.18	0.23	0.29	0.12
1	0.16	0.17	0.18	0.22	0.26	0.35	0.12
1.25	0.19	0.19	0.19	0.25	0.31	0.44	0.12
1.5	0.19	0.19	0.21	0.29	0.38	0.50	0.12
2	0.22	0.25	0.25	0.31	0.44	0.62	0.12
2.5	0.22	0.25	0.28	0.34	0.50	0.75	0.19
3	0.22	0.28	0.31	0.41	0.62	0.88	0.19
4	0.25	0.31	0.38	0.50	0.75	1.09	0.19
6	0.28	0.38	0.50	0.72	1.09	1.59	0.19
8	0.31	0.44	0.63	0.88	1.41	2.06	0.19
10	0.34	0.50	0.75	1.06	1.72	2.59	0.22
12	0.38	0.56	0.90	1.25	2.00	3.03	0.25
14	0.41	0.62	0.97	1.38	2.19	3.34	0.25
16	0.44	0.69	1.09	1.56	2.50	3.81	0.25
18	0.47	0.75	1.22	1.75	2.81	4.27	0.25
20	0.50	0.81	1.34	1.91	3.04	4.69	0.25
24	0.57	0.94	1.59	2.28	3.72	5.63	-
30	0.66	1.14	1.96	-	-	-	-
36	0.75	1.31	2.33	-	-	-	-

1.0 General Information

For general information regarding WEDGEPLUG™ valves, please refer to page 4 of this manual.

1.1

WEDGEPLUG™ valves have a unique operator and position indicator system. WEDGEPLUG™ valves when operated: lift, rotate a quarter turn and then reseal. Care should be taken that if using previous model Wedgetorque operators (Group 2, Group 3, Group 4, Group 4.5, Group 5.5, and Group 7), it is critical that the valve completes the initial lift, a 90 degree turn, and reseating or dropping the plug back into position. A WEDGEPLUG™ valve is not completely opened or closed unless the position indicator has shown this reseating movement. Updated Wedgetorque designs (models beginning with WT) are capable of mid-cycle reversal. The lift and subsequent reseating of the plug (as shown by the position indicator) is very slight, usually less than 1/2". Care should be taken to ensure that the valve is completely opened or closed. The lifting and reseating process takes place regardless of whether the valve is being opened or closed.

1.2

WEDGEPLUG™ valves are torque seated in both the open and closed positions.

1.3

Prior to installation, verify that the WEDGEPLUG™ valve will be installed with the stem in the vertical position. Consult PACIFIC VALVES® for installations with the stem in any other position.

1.4

It is recommended that WEDGEPLUG™ valves be insulated when line media temperatures are above 600°F.

1.5

A WEDGEPLUG™ valve generally closes by turning the handwheel (or wrench, etc.) clockwise.

2.0 Purging and Flushing

WEDGEPLUG™ valves in certain applications require purging and flushing to properly operate and maintain the valve. The purging and flushing function is performed automatically, every time the WEDGEPLUG™ valve opens or closes.

2.1

Purge lines should be connected to the factory supplied purge ports.

2.2

Purge media should be compatible with the process media and should be introduced into a WEDGEPLUG™ valve at a max of 50 psi over process media for steam, 50 psi for air, and 10 psi for liquid.

Consult PACIFIC VALVES® for process specific purging and flushing recommendations.

3.0 Adjusting the Wedgetorque Operator

WEDGEPLUG™ valves are adjusted at the factory for working pressures at ambient temperature unless otherwise specified on the order.

3.1

When WEDGEPLUG™ valves are correctly adjusted, they will operate as follows:

3.1.1

All WEDGEPLUG™ valves should operate between 1 and 1 1/4 turns of the operating screw

3.1.2

Excessive torque will not be necessary to seat the valve

3.1.3

The plug will lift approximately 1/4" to 1/2" before beginning to turn

Bolting Torque Values

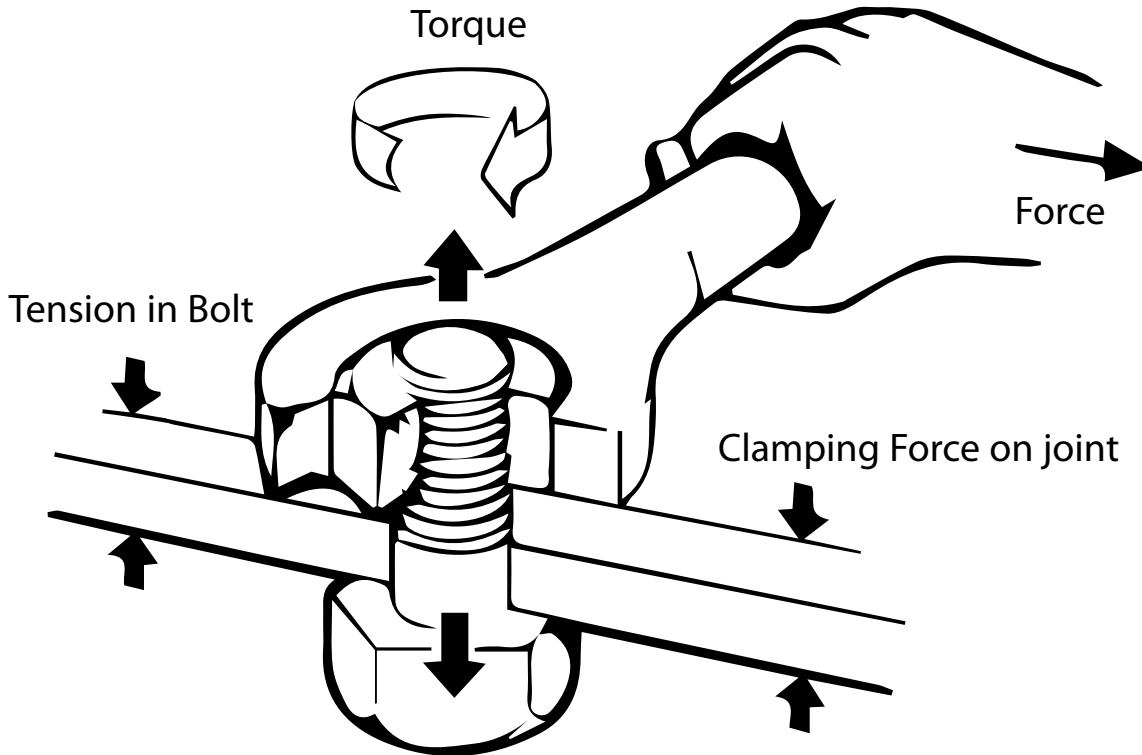

BOLTING TORQUE VALUES

1.0 General Information

For general valve operation & maintenance information please refer to page 4 of this manual.

This section details the specific torque values recommended by PACIFIC VALVES® for bolting used in all Pacific products.

2.0 Standard Procedures

2.1

Always use new bolting materials.

2.2

Verify that the materials are compatible with the process system as well as any temperature or pressure requirements. Note that bolting materials can have minor identification changes which may have a substantial impact on performance, ie. B7M vs. B7.

2.3

Whenever allowed by system and process parameters, use appropriate lubrication to ensure even tightening of the bolting materials. For higher temperature applications, the use of an "Antisieze" compound may be necessary to promote future disassembly.

Bolting Torque Values

3.0 Torque Values

All values are listed in foot/pounds (ft/lbs.)

Bolt Dia.	TPI	ASTM A193 GR B7, B16, & K-500 monel with a bolt stress of 60,000 psi	ASTM A193 GR B8 class 2, & B8M with a bolt stress of 45,000 psi
1/4	20	20	16
5/16	18	30	22
3/8	16	45	34
7/16	14	60	47
1/2	13	90	65
9/16	12	120	90
5/8	11	160	120
3/4	10	270	200
7/8	9	500	300
1	8	700	450
1 1/8	8	875	650
1 1/4	8	1200	900
1 3/8	8	1625	1200
1 1/2	8	2100	1590
1 5/8	8	2750	2000
1 3/4	8	3400	2570
1 7/8	8	4250	3200
2	8	5200	3880
2 1/4	8	7400	5575
2 1/2	8	10000	7685
2 5/8	8	11800	8900
2 3/4	8	13700	10200
3	8	17750	13350



Long Term Storage of Valves

LONG TERM STORAGE OF VALVES

1.0 General Information

For general operation & maintenance information regarding for valves, please refer to page 4 of this manual.

2.0 Storage

The following recommendations are for preparing valves and their accessories for long term storage. They are necessary to maintain the valves in proper condition prior to installation into the pipeline. By following these procedures, abrasive and corrosive substances can be prevented from affecting valve performance.

It is the purchaser's responsibility to take the necessary precautions for the protection of valves in storage.

2.1 As shipped condition

Valves are packaged with a moisture resistant closure on the valve ends. Where size permits, plastic plugs or caps are used. On larger size valves, plastic or wood covers are sealed with tape and securely attached with metal bands. All other openings are covered with plastic caps or plugs.

Parts packaged separately are secured in packaging from the factory to prevent damage during handling and storage. These parts are to be stored off the ground in an area protected from the weather. If it is anticipated that the valve will be in storage for more than 4 months the packing should be removed and shipped dry.

2.2 Recommended storage facilities

The following are a list of storage types in order of most preferred to least preferred:

- Enclosed weather tight building with a concrete floor.
- Enclosed building with a dirt floor. Valves must be on pallets.
- Open air, valves on pallets on a concrete floor covered with a tarpaulin (this is not recommended for more than six months)
- Open air, valves on pallets on a dirt floor and covered with a tarpaulin (this is not recommended for more than six months)

2.3 Inspection

Periodic inspections should be performed on all stored valves and parts. The frequency of these inspections should be determined by the type of storage facilities and weather conditions. At a minimum, all parts and valves should be inspected every 4-6 months. Inspect for dirt, moisture, or any other type of contamination. If any is found the valve is to be thoroughly cleaned and dried. Repeat the above listed packaging procedure to ensure the valve is weather tight. Slight external rusting may

occur on valves stored outside. This will have little or no effect on their performance. Heavy internal rust, however, may be harmful and must be corrected. If stored longer than 4 months, the packing must be replaced.

2.4 Preparation for installation into the pipeline

Inspect valves as per the above instructions and remove any contamination, assuring that the valve is clean and dry. Re-torque all bolting to factory specifications to compensate for possible bolt relaxation, which may occur during long storage. Ensure that all foreign material has been removed from the valve and that it is dry.

VALVE INSTALLATION

1.0 General Information

For general valve information, please refer to page 4 of this manual.

2.0 Introduction

By exercising proper care in the installation of PACIFIC VALVES®, the probability of trouble-free service will be enhanced. It is important to recognize that in the transport, handling, and storage of a valve between the time of manufacture and the time of installation, there are numerous possibilities for accident or error, which may affect valve performance.

All valves should be handled/installed in such a manner as to comply with all applicable state, local and federal safety regulations including, but not limited to OSHA regulations. Personal Protective Equipment (PPE) should also be used in compliance with all regulations.

3.0 Inspection and handling

Before installation of the valve, it is important to determine that the valve is in satisfactory condition. It may be helpful to observe the following points, in order to avoid subsequent valve problems:

3.1

Carefully unpack the valve and note any special warning tags or identification plates attached to the valve; take appropriate action.

3.2

Check valve for any markings indicating flow direction. If flow direction is indicated, appropriate care should be exercised to install the valve in the proper flow orientation. Check valves and non-return valve are uni-directional and must be installed in the proper orientation.

3.3

Inspect the valve interior through the end ports to determine that it is clean and free from foreign matter and/or corrosion. Remove any special packing materials (blocks to prevent disc movement) or packages of desiccant. The wedge/discs of weld end gate/globe valves should be slightly open during welding of the valves into the pipeline.

3.4

Check the pipeline to ensure that it is properly aligned and supported. Expansion joints or bends should be installed in the

pipeline to compensate for expansion and contraction.

3.5

Only qualified riggers should handle the valves. The pick up point for all PACIFIC VALVES® is by the use of a strap or chain around the neck area of the valve body. Do not pick up PACIFIC VALVES® by use of straps or chains on or around the handwheels, yoke, bevel gear, motor or cylinder operator, or any override attachment. Do not pick up a valve by the packing bolting or other interior connections. After the weight of the valve is supported by a strap or chain around the neck of the valve body, other lines may be attached for steadying the valve in place during installation.

3.6

Immediately prior to valve installation the interior of the piping (to which the valve is to be attached) should be checked for cleanliness and free from foreign materials.

4.0 Installation

All valves should be installed in such a manner as to prevent exposure to excessive vibration and process flow turbulence. Check valves specifically are subject to increased turbulence and wear due to their position in a piping system.

When PACIFIC VALVES® with bevel gear, motor or air cylinder operators are mounted in a position other than with the valve stem in a vertical position, contact PACIFIC VALVES® for specific instructions.

4.1 Weld End Valves

Welded joints, when properly made, provide a structural and metallurgical continuity between the pipe and the valve body. For socket weld joints it is usually required that the weld fillet have more cross sectional area than the pipe. Butt welds usually require full penetration and thickness at least equal to that of the pipe. If a pipe of a high strength alloy is welded to a valve with body material of lower mechanical strength, the weld usually must taper to a compensating greater thickness at the valve end, or the valve must have a matching high strength welded-on extension or "pup".

CAUTION! All welding should be done in accordance with any code or jurisdictional regulations applicable to the piping system construction and with complete and approved welding procedures, and inspected as required by applicable specification. The following items are a general overview of sound welding practice:

4.1.1

Check material markings on pipe and valve to confirm they are as specified.



Valve Installation

4.1.2

Inspect welding end surfaces, dimensions, and cleanliness. Correct any condition that might interfere with assembly and satisfactory welding.

4.1.3

If backing rings are to be used, check to confirm that the ring material is compatible with the pipe and valve materials, check individual rings for fit and cleanliness.

4.1.4

Determine that the prescribed welding parameters including preheating and post weld heat treating if required, are in accordance with the approved welding procedure.

4.1.5

Inspect valve-pipe end alignment; adjust if and as required.

4.1.6

Securely tack weld.

4.1.7

Complete weld, using approved welding procedure.

4.2 Flanged Valves

Pipe flanged joints depend on tight sealing and compressive deformation of gasket material between facing flange surfaces. The bolting must provide the mechanical force necessary to maintain the necessary compressive stresses on the gasket, as well as resist the normal pressure forces tending to separate the joint. It should be recognized that bolting force used for "brute force" alignment of misaligned flanges will not be available to sustain gasket loading and pressure force loading, and the result may be a joint leakage problem.

4.2.1

Check mating flange facings. If a condition is found which might cause leakage, (e.g. a deep radial groove or cut), do not attempt to assemble until the condition is corrected.

4.2.2

Check bolting for proper size, length and material.

4.2.3

For flange bolting for steel flanges ANSI Class 400 or higher, high strength material (usually B - 7) is required. The proper matching of flanges, bolting and gaskets is important.

4.2.4

Check gaskets for obvious defects or damage.

4.2.5

Use care to provide good alignment of flanges being assembled. Use suitable lubricants on bolt threads. When assembling, sequence the bolt tightening (in a star pattern) to make initial contact of flanges and gaskets as flat and parallel as possible. Tighten gradually and uniformly to avoid tendency to twist one flange relative to the other. Use of torque wrench is important to assure correct and uniform final tightening of flange bolting.

4.2.6

Parallel alignment of flanges is especially important in the case of assembly of a valve into an existing system. It should be recognized that if the flanges are not parallel, in such instances, it would be necessary to bend something to make the flange joint tight. Simply forcing the flanges together with the bolting may bend the pipe, or it may bend the valve. In large diameter piping particularly, such conditions should always be brought to the attention of someone capable of evaluating the bending conditions, and corrective measures taken as needed.

4.2.7

CAUTION! As indicated above, torque wrenches should be used for flange bolting. If, in the tightening process, the torque on a given bolt has been increasing with each part turn, and then is observed to remain unchanged or increase a much lesser amount with an additional part turn, that bolt is yielding. Such bolt should be replaced and scrapped.

4.3 Threaded Valves

For tight sealing, threaded pipe joints depend on a good fit between the male and female pipe threads, and, usually, the presence of a special soft or viscous material between the assembled threads. For best assurance of a leak-free system the following points should be observed:

4.3.1

Check the threads on both the valve and the mating pipe for form and cleanliness. Inspect for obvious dents, deformation of the thread or out-of-round areas. Ensure that no chips or grit are present.

4.3.2

Note internal length of threads in valve ends, and proximity of valve internal seat or wall. Observe any need for care regarding how far the pipe is threaded into valve. If there appears to be a possibility of a problem, carefully check the pipe end thread, to make sure there is no extended straight portion beyond the standard tapered sections.

Valves Installation

4.3.3

Use care to align threads at point of assembly. Tapered pipe threads are inherently loose fit at entry; substantial wrenching force should not be applied until it is apparent that threads are properly engaged.

4.3.4

Apply appropriate tape or thread compound to the external pipe threads (except when dry seal threading is specified).

4.3.5

Assemble joint wrench-tight. Wrench on valve should be on the valve end into which the pipe is being threaded.

CAUTION! Because there is no clear limit on the torque that may be developed in a tapered thread joint, it is possible to damage valves by applying excessive twisting forces through the body.

4.3.6

Repeat the process at second valve end. Again apply wrench at end of valve to which pipe is being assembled.

5.0 TESTING AND ADJUSTMENT

5.1

When a valve has been properly inspected and installed, it is reasonable to assume it will be in good condition and ready to operate. Nevertheless, it is at this time that the valve is at the end point of its more vulnerable phase. Operability can be proven only by test.

5.2

At this point, valves having adjustable stem seals should be checked to determine that packing has been properly installed and gland bolting has its initial adjustment. Additional adjustment should be determined according to need as valve operability is checked and as system pressure is introduced.

5.3

A first observation can be made by actuating the valve through an open-close, or close-open cycle. If no obvious problems are observed, an actual test at pressure may be applied while tightness and operability are checked.

5.4

It is a fairly common practice after the installation of piping systems to clean the systems by blowing with gas or steam or flushing with a liquid to remove debris and/or internal protective films and coatings. It should be recognized that valve cavities may form a natural trap in a piping system and material not

dissolved in or carried out by the flushing fluid may settle in such cavities and adversely affect valve operation. Also, abrasive material carried by a high velocity fluid stream may cause serious damage to seating surfaces. Again, great care should be taken to ensure that the valve is free of all debris prior to operation.

5.5

Upon installation, new valve lubrication should be applied to all lubrication points.



Packing & Gasket Maintenance

1.0 GENERAL INFORMATION

1.1

For general valve operation & maintenance information please refer to page 4 of this manual.

2.0 PACKING MAINTENANCE

2.1

Inspection of the valve stem/bonnet seal should be an essential part of routine monthly valve maintenance inspections.

2.2

If inspection indicates the seal is leaking, the bolts holding the gland flange should be tightened uniformly (one-quarter of a turn at a time) until leakage stops.

CAUTION! Extreme care should be taken when working on or around any pressurized equipment. Tightening of bolting beyond this point results in over-compression of the packing against the stem, thereby producing excessive wear and loss of packing material. If difficulty is experienced in achieving satisfactory sealing without producing excessive stem friction, it may be desirable to increase or to replace the packing material.

2.3

If gland travel is fully taken up and leakage does not stop, a careful examination of the stem should be undertaken. Operation of a valve on a regular basis will minimize corrosion between the stem and packing material. Any deterioration of the stem surface which is in contact with the stem seal or packing (such as dents, scratches, pitting or general corrosion) must be recognized as a probable cause of leakage problems. The valve stem should be examined to determine if it has become bent or misaligned. If any of the above conditions exist, the stem must be refinished or replaced. If the stem is undamaged and the valve continues to leak, addition to or replacement of the packing is necessary.

2.4

Replacement packing should be dry and free of all types of contamination prior to installation in the stuffing box. The new packing should also be compatible with both the valve stem material and the material in the piping system, at operating temperatures and pressures.

CAUTION! It is extremely dangerous to remove the bolting, gland flange and gland to replace the packing with pressure in the pipeline. Always depressurize the valve/pipeline before dismantling the stuffing box. Although specific procedures may vary with specific valve and packing designs, the following rules always must be considered.

3.0 PACKING INSTALLATION AND INSTRUCTIONS

3.1

Remove/drain system pressure from the valve.

3.2

Loosen and remove nuts holding gland flange in place. At this time, the gland flange and the gland will be free to move up the stem and the stem packing is exposed (refer to appropriate valve section for identification of parts).

3.3

Remove old packing. Use caution to ensure that tools used to remove packing do not scratch either the stem shaft or the inside of the stuffing box. Clean shaft and box thoroughly.

3.4

Replace original packing with packing indicated on the applicable spare parts listing. (In most cases, the packing will be a die-formed graphite/ braided carbon set). Use all new packing. Never install used rings.

3.4.1

To open split ring joints, twist the open ends in opposite directions (the packing ring should resemble an "S"). Install each new packing ring separately, tamping each one before installing the next. Ensure that rings are not cocked and that air is not entrapped between adjacent rings.

3.4.2

The joints of split packing rings should be staggered 90 degrees to 120 degrees from the joints of adjacent rings.

3.4.3

If the valve has a lantern ring, make sure it is replaced in its original position.

3.4.4

The gland may be used to set the packing in the bottom of the stuffing box.

3.5

Replace the gland and gland flange and hand tighten the gland nuts. Then tighten the gland nuts to approximately 40 ft. lbs.

3.6

Manually open and close valve several times to ensure all parts are working smoothly under pressure and to help "set" the packing.

Packing & Gasket Maintenance

3.7

After several days, inspect valve for leakage. Slight adjustment may be required.

3.8

The following suggestions apply if Chevron type Teflon Packing is used:

3.8.1

Ensure that sections of the lips of the rings are not turned over.

3.8.2

Ensure that the packing rings are facing in the direction of the medium being sealed - whether it is liquid or gas.

4.0 GASKET MAINTENANCE

NOTE: The following information refers primarily to valves that have been repaired/reconditioned previously. It is always a sound practice to inspect and maintain all sealing areas. Inspection of the valve body/bonnet joint should be a part of routine maintenance inspection after installation and startup. Flanged valves should have the flange ends inspected at the same time. In addition to improper gasket installation procedure, thermal changes, pressure changes, vibrations etc also may cause leakage. If re-torquing of the bolting does not stop the leakage, the flanged joint should be unbolted and the gasket carefully examined.

Observation Possible Remedies

- Gasket corroded: Select replacement material with improved corrosion resistance.
- Gasket Extruded: Select replacement material with better cold flow properties, select excessively replacement material with better load carrying capacity - i.e., more dense.
- Gasket Grossly: Select replacement material with better load carrying capacity, provide means crushed to prevent crushing the gasket by use of a stop ring or redesign of flanges.
- Gasket Mechanically: Review gasket dimensions to insure gaskets are proper size. Make certain damaged due to gaskets are properly centered in joint overhang of raised face or flange bore.
- No Apparent Gasket: Select softer gasket material. Select thicker gasket material. Reduce compression visible gasket area to allow higher unit sealing load. Inspect flange dimensions. Gasket substantially Indicative of excessive "flange rotation" or bending. Alter gasket thinner on O.D. dimensions to move gasket reaction closer to bolts to minimize bending than I.D. movement. Provide stiffness to flange by means of back-up rings. Select softer gasket material to lower required seating

stresses. Reduce gasket area to lower seating stresses.

- Gasket Unevenly: Improper bolt-up procedure followed. Make certain proper sequential compressed around bolt up procedures are followed circumference.
- Gasket thickness: Indicative of "flange bridging" between bolts or warped flanges. Provide varies periodically reinforcing rings for flanges to better distribute bolt load. Select gasket material with lower seating stress. Provide additional bolts if possible to obtain better load distribution. If flanges are warped, remachine or use softer gasket material.

5.0 GASKET INSTALLATION PROCEDURES

Regardless of the type of gasket being used or the materials of construction, certain basic procedures must be followed during assembly to ensure proper operation. The procedures should be followed whether bolt stresses will be achieved with ordinary stud wrenches, preheating studs, using tensioning devices, using torque wrenches, or using hydraulic wrenches.

5.1

Inspect the gasket seating surfaces. Look for tool marks, cracks, scratches or pitting by corrosion and make sure that the gasket seating surface is proper for the type of gasket being used. Radial tool marks on a gasket seating surface are virtually impossible to seal regardless of the type gasket being used, therefore every attempt must be made to minimize them.

5.2

Inspect the gasket. Make sure the material is as specified, look for any possible defects or damage in the gasket.

5.3

Inspect and clean each stud or bolt, each nut, each washer, and the facing on the flanges against which the nuts will rotate. Look for severe galling, pitting, etc. If any of the above mentioned items are damaged beyond repair, replace the damaged item.

5.4

Lubricate all thread contact areas and nut facings. The importance of proper lubrication cannot be overstressed. No joint should be made up without the proper lubricant being applied to the threaded surfaces and to the nut facings. When flanges will be subjected to high temperatures, the use of an anti-seize compound should be considered to facilitate subsequent disassembly.



Packing & Gasket Maintenance

5.5

With raised face and flat face installation, loosely install the stud bolts on the lower half of the flange. Insert the gasket between the flange facing to allow the bolts to center the gasket on the assembly. Install the balance of the bolts and nuts and bring all to a hand-tight or snug condition.

5.6

If the gasket is being installed in a recess or a groove, center the gasket midway into the recess or the groove. If the joint is vertical it may be necessary to use some cup grease or a few dabs of gasket cement or some other adhesive compatible with the process fluids, to keep the gasket in position until the flanges are tightened.

5.7

Torque the bolts up to a maximum of thirty percent of the final torque value required following a pattern resulting in evenly applied torque. Number bolts so that torquing requirements can be followed. With any gasket material, it is extremely important to follow a proper bolting sequence. If this sequence is not followed, the flanges can be cocked. Then, regardless of the amount of subsequent torquing, they cannot be brought back parallel. This problem, of course, is maximized on metallic gaskets more so than on non-metallic.

5.8

Repeat step 5.7, increasing the torque to approximately 50 to 60 percent of the final torque required.

5.9

Continue with a star pattern of re-torquing all studs or bolts to the desired amount until no further rotation of the nuts can be achieved. This may require several re-torquings since as one stud is torqued it will relieve the stress on the adjacent stud until such time as equilibrium is achieved.

5.10

On high-pressure, high-temperature applications, it is recommended that the flanges be re-torqued to the required stress after 24 hours at operating pressures and temperatures to compensate for any relaxation or creep that may have occurred.

6.0

Gaskets are designed and manufactured with 30 Deg Angles.

6.0.1

Please note that the gasket will form to the existing bonnet angle during installation.

6.1

Gaskets have tape holding the caps or wires in place for shipping and installation purposes.

6.1.1

Please note: Tape should not be removed.

6.2

Like all graphite seals, Pacific Valve gaskets are compressible, and thus are taller than standard metal pressure seals prior to installation.

6.2.1

Please note PACIFIC VALVES® graphite gaskets will compress during installation and initial system pressurization.

6.3

In some rare cases the pre-installed graphite gasket height may prevent the segment rings from being installed. If this occurs one or both of the following steps may be used:

6.3.1

With the backing ring on the gasket apply pressure using a plastic or brass pin and hammer

6.3.2

(And / Or) You may leave the backing ring out and pull the gasket up against the segment rings until the required amount of compression has taken place for the backing ring to be installed.

7.0

Follow all safety related protocols for valve repair before performing the steps listed below

7.1

Before bonnet disassembly:

7.1.1

Measure and record the stud length from the bottom of the nut to the top of the stud.

7.2

Disassemble per the valve manufacturer's instructions or facility guidelines.

Packing & Gasket Maintenance

7.3

Measure the metal gasket height. Subtract the metal gasket height from the graphite gasket height to ensure that there is Packing & Gasket Maintenance sufficient stud length for assembly.

7.3.1

Inspect the sealing area per facility guidelines.

7.4

Assemble the valve components per the PACIFIC VALVES® IOM instructions. Should damage occur to the graphite gasket during assembly, please contact PACIFIC VALVES® Engineering for engineering approval.

7.5

Bonnet alignment during pull-up is very critical. Please locate an area on the valve where measurements can be taken to check for any tilting or misalignment.

7.6

Torque requirements for bonnet fasteners are listed on page 11 of the IOM. Calculate 30% of the assembled torque and start tightening the fasteners using a cross pattern technique.

7.7

Check for alignment and continue torquing the fasteners to 60% using the same technique.

7.8

Check for alignment and continue torquing the fasteners to 100% using the same technique.

7.9

Once the initial 100% is reached check for alignment and continue torquing the fasteners in a clockwise pattern until all fasteners are at a constant 100% torque value.

7.10

Retorque each fastener to 100% once the valve is at normal system operation pressure.



Gear & Motor Actuated Valves

Gear And Motor Operators

1.0 Theory Of Operation

Most valves, which are located in an accessible environment, are operated by a manual hand-wheel mounted directly on top of the valve. When the valve size or differential pressure is so great that the handwheel size cannot keep the operating handwheel pull within customer reasonable limits, then a bevel gear should be mounted on the top-works. In addition, many customers require remote operation or operating times that are not possible with manual handwheels, in this case Electric Motor Operators (EMO's) can be used. Note! Operator limit and torque settings are factory set during valve testing for ANSI cold working pressure tests. Additional adjustment may be required in the field. Contact PACIFIC VALVES® with any questions.

⚠ WARNING

Do not use excessive air wrench torque or snipes on handwheels as the gearing or valve stem could be damaged!

2.0 Installation

Ensure that the electric motor operator is wired correctly and phased properly prior to operation. Do not allow the valve to travel in the wrong direction (when phased is reversed). This can result in damage to the valve and void all valve warranties.

3.0 Maintenance

The gear or electric operator itself should never require disassembly and it is recommended that this be done only by the operator manufacturer. If it becomes necessary to disassemble the valve, the operator assembly must be removed first.

The preferred orientation for Pacific gear and motor operated valves is in horizontal pipelines with the stem in a vertical position. When installed in any other position, motor operated valves should be supported by means of a support clamp around the motor mounting plate. Please contact PACIFIC VALVES® when specifying an operated valve with an orientation different than that listed above.

3.1 Preventive Maintenance

3.1.1

With the operator removed from the valve, and operator drive nut for thread wear, galling or binding.

3.1.2

If excessive wear is evident, worn parts should be replaced.

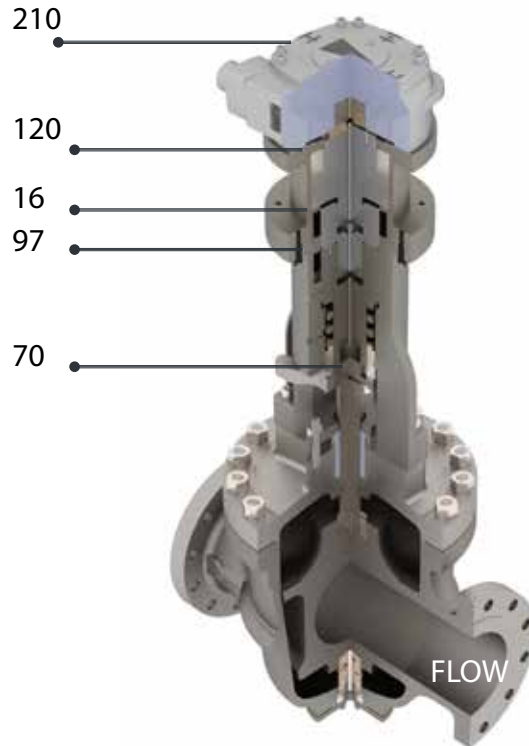

4.0 Disassembly

4.1

Remove operator mounting bolts (97) from Wedgetorque operator (70).

4.2

Attach a support sling around operator 210 and prevent rotation.

4.3

Turn handwheel closed to turn operator off from stem and then lift gear operator off. In the case of an electric motor operator it may be necessary to disengage or "de clutch" the motor before using the manual handwheel. The electric motor Operator manufacturer's manual should detail this procedure.

Gear & Motor Actuated Valves

Note: Prior to the disassembly of any valve equipped with an Electric Motor Operator, ensure that all electrical sources have been disconnected and the appropriate lockout/tagout procedures have been used.

4.4

Proceed with disassembly instructions given in the appropriate valve maintenance instructions.

5.0 ASSEMBLY

5.1

Install spacer, if used, and coupling.

5.2

Lift gear operator carefully over valve stem and while preventing operator from rotating, turn handwheel open until operator aligns over mounting holes.

5.3

Loosely installed mounting bolts (97) on Wedgetorque Operator (70) and check for smooth operation.

5.4

Torque mounting bolts (97) while valve is in open position.

5.5

Set torque and limit switches in accordance with the instruction manual for the applicable operator.



Warnings

⚠ WARNING

All PACIFIC VALVES® are designed and manufactured to be installed in applications where no more than 1g of force in excess of gravity is applied to the valve in any direction. This 1g force can be an effect of Traffic, Wind or Earthquake. PACIFIC VALVES® should not be used in applications that exceed 1g.

⚠ WARNING

All piping system components are subject to certain levels of erosion and corrosion. As the valve wall thickness is the governing variable in overall service life, care should be taken to ensure that all valves and related piping components are of a suitable wall thickness for the given application. Periodic inspections should also be made as valves/components may wear over time. As a minimum, annual inspection of valve body and bonnet wall should be performed with calibrated measuring devices such as micrometers and/or ultrasonic thickness gauges. Severe applications may require additional inspection types and/or frequency. Additionally, valves should be inspected for general signs of component wear and/or damage caused by process media, i.e. steam cutting. This may include the removal of insulation and/or other coverings to ensure a proper inspection. All valves should also be cycled completely during these inspections to ensure proper operability. Care should be taken to ensure that this will not affect the operating system.

⚠ WARNING

The style, size, pressure class and material selection of all valves is the responsibility of the piping system designer. PACIFIC VALVES® may offer suggestions in this area; however, the selection process is solely the responsibility of plant designers. Plant designers should also consider the specific effects that the process media will have on the valve wall thickness and corresponding service life and ensure that the selected material is compatible with the process media. This material selection should be based on reputable corrosion resistance data and used in conjunction with the valve's corrosion allowance to maintain the minimum wall thickness. See Table 1 for wall thickness and corrosion allowance data. It is also the responsibility of the piping designer to ensure that valves are equipped with any necessary venting and/or draining capabilities.

⚠ WARNING

Do not exceed 100% of the maximum pressure rating of the valve at any time during its operation. Pressure spikes beyond the valve's pressure rating are solely the responsibility of the user.

⚠ WARNING

When operating any valve stand clear of any moving parts such as the stem and/or disc assembly.

⚠ WARNING

All manually operated PACIFIC VALVES® are designed for hand input. Do not apply excessive input torque via pipe wrenches "cheater bars" or other devices.

⚠ WARNING

Motor operated valves should be left in their factory set condition, unless the system operating parameters dictate a change. If changes are necessary, they should be performed in small increments and then the valve operation inspected. When adjusting these settings, use only the lightest/lowest setting possible to achieve the desired performance. Excess torque and/or thrust in the motor settings, may damage or lockup the valve. Never remove a motor operator, gear operator or manual operating assembly from a valve while it is pressurized. The valve must be completely relieved of all pressure prior to this disassembly.

⚠ WARNING

Care should be taken to ensure that electrical motors are wired correctly to the power source. Incorrect phasing of 3-phase wiring may cause valve/motor damage.

⚠ WARNING

The operator of any valve should understand the effects of opening/closing the valve with regards to its role in the overall piping system. Operators of valves under pressure should take caution to ensure that the valve is in good operating condition prior to operating it under pressure.

⚠ WARNING

Certain valve applications take place at elevated temperatures. Care should be taken in these instances to ensure that an operator does not touch any portion of the valve other than the handwheel. In severe temperature applications (300 degrees F and above), insulation may be required on the valves to protect operators from the heat.

⚠ WARNING

Certain processes utilize flammable, caustic and/or otherwise unstable media. Care should be taken in these circumstances to ensure the operator is aware of the specific health and safety risks associated with that medium.

⚠ WARNING

All PACIFIC VALVES® should be operated within the pressure and temperature ranges listed in ASME B16.34. Under no circumstances should the valves be operated at conditions outside this standard.

⚠ WARNING

All piping systems should contain independent support mechanisms and should not utilize the valve as a sole means of support.

⚠ WARNING

The estimated total lifespan for PACIFIC VALVES® when installed within ideal boundary conditions is 20 years.

⚠ WARNING

All valve actuators shall be sized by referring to the specific relevant valve torque and thrust data published by PACIFIC VALVES®. Generic or standard valve information shall not be used.

⚠ WARNING

It is the ultimate responsibility of the piping designer to ensure that each valve is sized appropriately for the given system parameters of pressure, temperature, flow rate, velocity, pressure drop, etc. Additionally, it is the responsibility of the piping designer to ensure that the corresponding actuator sizing data is correct for the given application.

⚠ WARNING

WEDGEPLUG™ valves should not be used for throttling applications. Severe damage may occur if used for throttling.



Warnings

⚠ WARNING

WEDGEPLUG™ valves shall only be used within their defined boundary conditions. All standard materials of construction, including bolting are suitable for operation within the boundary conditions listed in section 7.0 of this document. Care should be taken to ensure that all valves are not operated at conditions that exceed or deviate from the defined boundary conditions. The boundary conditions must be adhered to regardless of the piping system status, including but not limited to: Start-up, hydro-testing, chemical cleaning, system flushing, etc.

⚠ WARNING

Valves are not suitable to serve as block valves during system hydrostatic pressure tests that exceed 1.1 times the cold working pressure.

⚠ WARNING

Care should be taken around all valves as injury or damage may occur from the leakage of hot, high pressure and/or caustic materials from a gasket and/or packing joint. Additionally, packing and/or gasket leaks may cause external corrosion damage to the valve.

⚠ WARNING

When possible, gate valves should be relieved of maximum seating force when left in the closed position. By relieving this force, it may help prevent damage caused by excessive thermal stem expansion. Care should be taken to ensure that the valve is not opened, only that the torque/thrust has been removed from the stem.

⚠ WARNING

It is the responsibility of the user/owner of a plant to ensure that all valve operators are ordered to meet all applicable requirements and specifications.

⚠ WARNING

Only valves that have been certified as fire safe shall be used in piping systems that may be exposed to fire.

⚠ WARNING

Standard graphitic packing is suitable for 500ppm VOC emissions. Consult the factory if lower emissions are required. Crane Pacific meets API-622 / Method 21 emissions standards.

⚠ WARNING

When operating manual valves, gloves should be worn to minimize the risk of injury to the hands.

⚠ WARNING

In situations where manual valves are difficult to operate due to substantial torque requirements, it is recommended that the valve be supplied with a gear or motor operator.

⚠ WARNING

All valves should be mounted with the stem vertical and the pipeline horizontal. Swing check and tilt disc valves may be installed in vertical pipelines only when the normal flow is in the upward direction. For other valve types and any other orientation, please contact the factory.

⚠ WARNING

Depending upon the specific application, normal lubricants may not be sufficient for higher temperature applications. In this case, higher temperature lubricants should be used in place of the standard type.

⚠ WARNING

All valve packing glands should be tightened in an even manner. Care should be taken to ensure that the packing gland and/or gland flange do not contact the valve stem or stuffing box during tightening.



CRANE CHEMPHARMA & ENERGY

4526 Research Forest Drive,
Suite 400
The Woodlands
Texas 77381, U.S.A.
Tel.: +1 936 271 6500

Xomox Chihuahua, S.A.

Juan Ruiz de Alarcón 313,
Complejo Industrial Chihuahua,
31136 Chihuahua
Mexico
Tel: +52 614 442 9860

Crane Company, and its subsidiaries cannot accept responsibility for possible errors in catalogues, brochures, other printed materials, and website information. Crane Company reserves the right to alter its products without notice, including products already on order provided that such alteration can be made without changes being necessary in specifications already agreed. All trademarks in this material are the property of the Crane Company or its subsidiaries. The Crane and Crane brands logotype (ALOYCO®, BAUM®, CENTER LINE®, CRANE®, CRYOFLO®, DEPA® & ELRO®, DOPAK®, DUO-CHEK®, FLOWSEAL®, GYROLOK®, GO REGULATOR®, HOKE®, JENKINS®, KROMBACH®, NOZ-CHEK®, PACIFIC VALVES®, RESISTOFLEX®, REVO®, SAUNDERS®, STOCKHAM®, TEXAS SAMPLING®, WESTLOCK CONTROLS®, WTA®, and XOMOX®) are registered trademarks of Crane Co. All rights reserved.