



WEDGEPLUG



PROVEN PERFORMANCE IN THE MOST SEVERE SERVICE APPLICATIONS

WEDGEPLUG™
METAL SEATED VALVES
FROM PACIFIC VALVES®

CRANE

v in www.cranecpe.com



Heritage of Innovation and Quality

Crane Co. is a diversified manufacturer of highly engineered industrial products, founded in 1855. Crane has approximately 11,000 employees in the Americas, Europe, Asia and Australia, and is traded on the New York Stock Exchange (NYSE:CR).

Global Presence, Local Support.

With offices, manufacturing plants, distribution networks, and sales & service centers that span the globe, Crane CP&E is a worldwide leader in fluid handling products and solutions.



WEDGEPLUG™ Metal Seated Valves from PACIFIC VALVES® are chosen for delayed coker isolation where the service is not only high temperature, but presents other valve designs with seating issues when decoking occurs. WEDGEPLUG™ unique seating arrangement ensures that seats are protected from the media in both the seated open and seated closed position. Combined with the purging options during the opening and closing cycles, WEDGEPLUG™ Metal Seated Valves from PACIFIC VALVES® proves that there is no other valve with the design and experience, to handle severe services.

When you buy products from us, you get much more than just valves:

Performance Advantages

Compared with alternative valve designs, WEDGEPLUG™ Metal Seated Valves from PACIFIC VALVES® provides superior protection from: erosion damage; solids build-up on sealing surfaces and in cavities; residual freeze up which can prevent operation and cause leakage due to packing wear.

Effective and Versatile

Crane's WEDGEPLUG™ Metal Seated Valves from PACIFIC VALVES® non-lubricated metal-seated plug valves were designed more than 80 years ago to address valve problems associated with catalyst cracking service. Today, they are utilized readily in hot, dirty and severe refining applications, including delayed coking, ethylene cracking, asphalt production and residue reduction.

Quality Assured

WEDGEPLUG™ Metal Seated Valves from PACIFIC VALVES® are designed to ASME B16.34, API Standard 599 and API Standard 600, latest edition, where applicable. Testing is to API Standard 598, latest edition. Special hydrostatic testing and non-destructive examinations are available.



Key Features & Benefits

KEY FEATURES & BENEFITS

With industry-leading low steam usage and zero steam consumption when not actuating, the WEDGEPLUG™ Metal Seated Valves from PACIFIC VALVES® delivers superior operational savings and reduced total cost of ownership.

- 1 As the WEDGEPLUG™ consumes steam only during activation (actively opening or closing), not only are steam costs reduced but downstream process yields are improved and system corrosion rates reduced.
- 2 Additionally, any loss of steam pressure when the valve is seated does not affect valve function, reliability or safety.
- 3 Top entry design allows the body to stay in the piping while the top works are removed for inspection, hydro-blasting and maintenance. This reduces rigging and pipe work costs and shortens turn around schedules and reduces the overall cost of maintenance throughout the life of the valve.
- 4 Metal-to-metal bi-directional seal eliminates orientation concerns and delivers double block and bleed/purge capability in a single valve, increasing operational safety.



(Plug Detail)

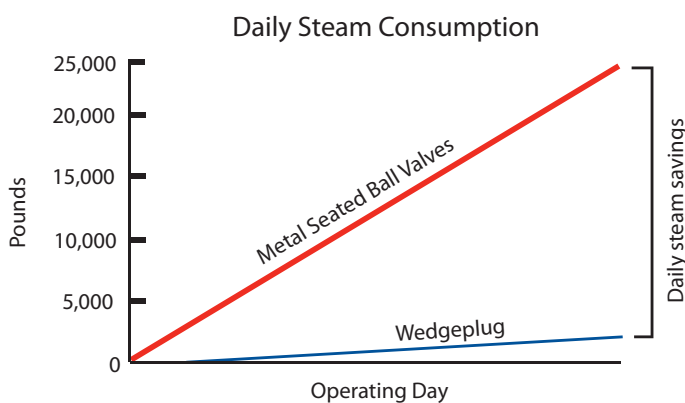

WEDGEPLUG™ Technical Specifications

Simplifying Severe Service

Process valves in severe service applications are especially susceptible to the negative effects of wear, which can reduce their performance and lifecycle. The compressive interface of sealing elements in traditional WEDGEPLUG™ designs make the introduction of highly-abrasive fluids especially problematic, as they attack machine finishes and impede the valve's ability to function. WEDGEPLUG™ Metal Seated Valves from PACIFIC VALVES® eliminates this action and reduces valve deterioration with frictionless operation between elements. This design extends valve reliability during shutoff and reduces repair costs in extreme applications, delivering the lowest total cost of ownership.

- ASME Classes 150-1500.
- Temperature from cryogenic to 1650°F (900°C).
- Sizes ½ in (15 mm) through 36 in (900 mm).
- Plug port of reduced (70%, 90%) and full bore (100%).
- Designed to requirements of:
 - API 599
 - ASME B16.5 flanges
 - ASME B16.10 face to face
 - ASME B16.34
 - Flanged, threaded or butt-welded
- Fire tested to API Standard 607, API Standard 6FA and British Standard BS6755.
- Materials include WCB, CF8M, C5, C12, WC6, WC9, and Incoloy 800H.
- Special configurations and alloys available.



Design Simplicity

Body

The body features dual, integral metal seats that provide metal-to-metal, bi-directional in-line sealing. The raised seats are completely protected from the process flow in both the fully-open and fully-closed positions. There are no cavities to permit process build-up, no leak paths behind the seat and no thermal expansion concerns. Inherently fire safe, a single WEDGEPLUG™ valve provides double block-and-bleed service. End connections include: raised face, ring joint and flat face flanges; butt weld; screwed ends; socket weld; and GRAYLOC® hub.

Seats

The unique lift-and-turn operation of the WEDGEPLUG™ valve allows the valve to operate with virtually no rubbing of the seat and plug. Because there is no contact during valve operation and the seats are protected from the process flow in both the open and closed positions, there is no need for overlays on the seats. The seats are integral to the body and ground to a mirror-like finish that matches the plug and ensures tight metal-to-metal sealing. Special metallurgy and hard-facing surfaces, including STELLITE®, can be furnished per customer request.

Bonnet

Top entry to the body allows in-line disassembly and repairability. The plug, stem, yoke and actuator can be removed as a single unit for inspection, cleaning and repair. This is a significant cost and maintenance benefit, especially for valve sizes 12" (300 mm) and larger.

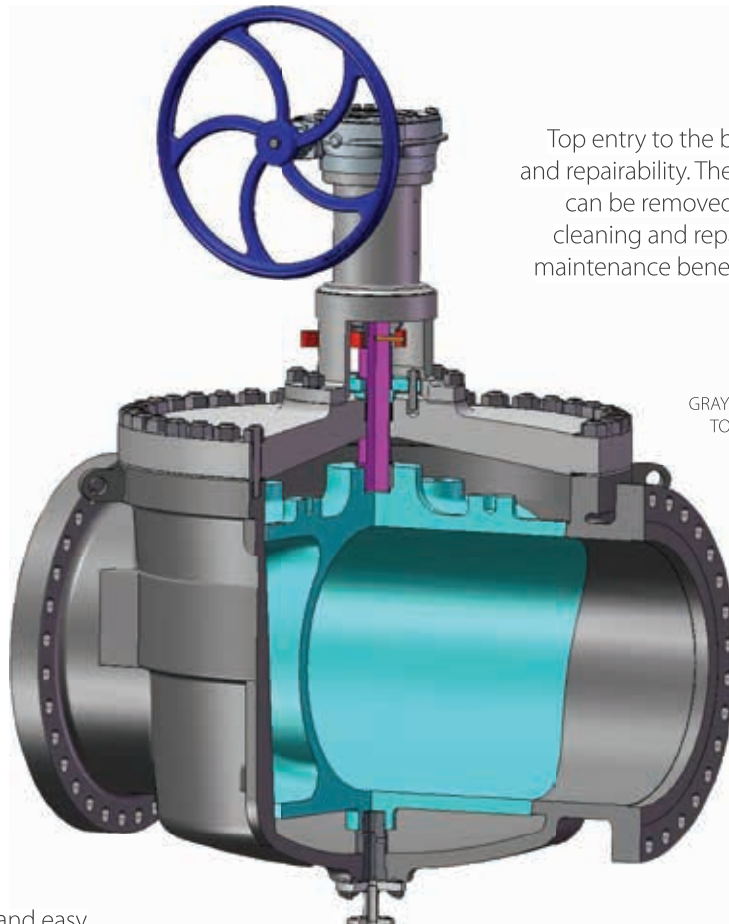

GRAYLOC® is a registered trademark of GRAY TOOL Company.

STELLITE® is a registered trademark of DELORO STELLITE, Inc.

Plug

Precision ground from hardened high-alloy material or overlaid stainless steel, WEDGEPLUG™ tapered plug ensures a tight seal and easy operation. The durable surfaces resist damage in the most severe applications, delivering years of reliable service.



The optional Q-plug provides full port flow along with less weight and easier maintenance. Other enhancements include trunnion mounting to eliminate side loads for prolonged seat life, tangential purge, and heavy-duty mounting yoke design.



Additional Features

Hard Seating Surfaces

Hard facings on the plug and body seats are not required due to the unique, non-contact turning motion of the WEDGEPLUG™ and can be furnished to customer request. The hardened metal plugs are then machined to a mirror-like finish for tight sealing and low torque. WEDGEPLUG™ valves with hard facings are recommended for high temperature corrosive and erosive steam and oil or oil vapor services.

A Choice of Seats

Metal-seated valves are recommended in extreme temperatures and abrasive media applications. Although hard facings are not required due to WEDGEPLUG™ unique method of operation and non-contact turning motion, they can be provided per customer request with special metallurgy.

Bonnet, Stem and Seal Options

- Heat dissipating fins for temperatures > 1,000°F (535°C).
- Trunnion mounts handle high differential pressures and prevent side loading.
- Packing and gland assembly with two-piece ball and socket-type joints assures alignment and proper packing compression without stem binding. Standard packing is GRAFOIL®. A wide variety of packing configurations is available.

Grafoil® is a registered trademark of GrafTech International Holdings Inc.

Purging and Flushing (see illustration page 9)

The unique seat action of the WEDGEPLUG™ valve delivers the industry's most efficient purge steam utilization. Unlike other designs that require a continuous steam flow, the WEDGEPLUG™ shuts off purge steam in the Unlike other designs that require a continuous flow of steam, the WEDGEPLUG™ only consumes steam while the valve is being cycled. While it is in a static open or closed position, the valve does not consume any steam positions, greatly reducing energy expenditures throughout the life of the valve.

Steam Jacketing

Steam jackets are available to handle highly viscous media such as tars and pitches. They may be obtained in ASME Class 150 and 300, sizes 1 ½ in (40 mm) thru 10 in (250 mm).

Simple Automation

Wedgetorque operators come standard with every valve. Providing optimum torque seating, they ensure tight bi-directional sealing while overcoming seat wear and process temperature variations. They enable easy manual operation or can be simply automated with electric, pneumatic or hydraulic actuators.

TYPICAL APPLICATIONS

Petroleum Refining Delayed Cokers

- Inlet/Transferline Isolation
- Overhead Isolation
- Module Isolation
- Heater Isolation

FCCU & RCCU

- Slurry/Cycle Oil Pump Isolation
- Catalyst Withdraw & Addition
- 3rd Stage Cyclone Block
- Strainer Isolation
- Cat Fines Block Valves
- Fractionators Emergency Shutdown Valve
- Coker Pot Strainer

Asphalt Plants

Residue Reduction

Petrochemical Ethylene/Steam Crackers

- Furnace Isolation
- Transferline Valves
- Decoke Valves
- Bypass Valves
- Strainer Isolation

MDI/MDA

Other

- Fossil Fuel Power Generation
- Fly Ash Handling

COAL GASIFICATION



Enhance Valve Performance

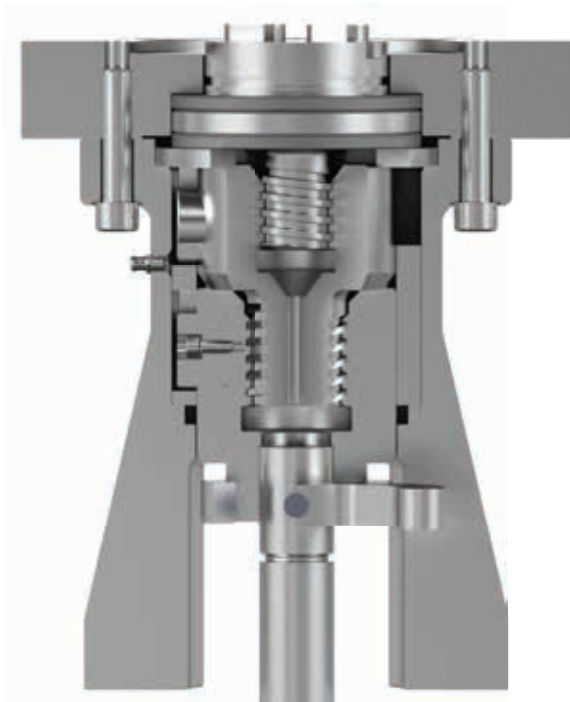

Wedgetorque Operators

All WEDGEPLUG™ valves are supplied with Wedgetorque operators to ensure optimum torque seating, providing the following features and benefits:

- The Wedgetorque lifts the non-lubricated plug and rotates it 90°, reseating it as torque is transmitted to the operating screw.
- The Wedgetorque provides positive seating using mechanical thrust, ensuring tight sealing of upstream and downstream seats.
- Automatic compensation for wear and process temperature variations.
- The Wedgetorque is manufactured and stocked in several group sizes for a full range of WEDGEPLUG™ valves.
- WEDGEPLUG™ valves originally supplied with screw-type operators can be retrofitted with new yokes and Wedgetorque operators.

Enhance Performance & Extend Valve Life

To provide consistent seating performance and prolonged valve life, it is recommended that you purge and flush your WEDGEPLUG™ Metal Seated Valves from PACIFIC VALVES® valve each time it is operated.

By purging and flushing, you can:

- Clean the seating surfaces, helping to deter damage caused from solids traveling in the process stream.
- Create a third dynamic seal in the valve in addition to the upstream and downstream seats by introducing the purge media.

Another benefit inherent in the WEDGEPLUG™ design is that the purge media is only consumed when the valve is being opened or closed. This greatly reduces the overall energy consumption and the subsequent removal of media from the process stream.

Guidelines for Purging and Flushing

Purge and flush WEDGEPLUG™ Metal Seated Valves from PACIFIC VALVES® using steam, air, nitrogen or process compatible liquids following these parameters to enhance valve performance.

- Steam purge must be applied at 25 PSIG min/50 PSIG max above process line pressure.
- Air or nitrogen purge must be applied at 25 PSIG min/50 PSIG max above process line pressure.
- Liquid purge must be applied at 5 PSIG min/10 PSIG max above process line pressure.
- To ensure maximum benefit, follow the guidelines below when establishing purging and flushing procedures.
- Purge media should be compatible with process media.
- Systems temperature and purge temperature should be similar.
- Supply lines should have no restrictions (orifices) without prior consultation of WEDGEPLUG™ Metal Seated Valves from PACIFIC VALVES®.
- Supply header should be sized for adequate volume.
- Pressure and temperature gauges should be placed in critical areas to monitor purge media.
- Steam purge lines should be as short as possible to prevent condensate build-up.

Illustrated Purging Process

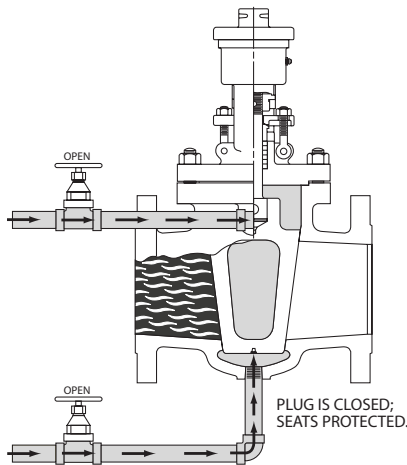

In this picture, the valve is in the closed, seated position with the seats protected. The line media is colored and the purge/flush media is shaded yellow.

With the valve, we have three sealing elements:

- The upstream primary mechanical seal of the plug against the body.
- The internal static purge, i.e., steam seal.
- The downstream secondary mechanical seal of the plug against the body.

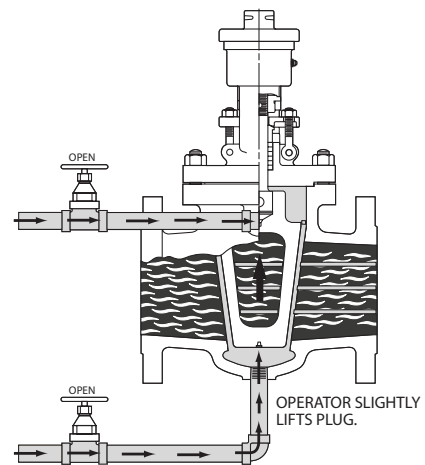

The plug is slightly lifted (approximately 1/4 to 1/2 inch) causing a high velocity flushing action of the line media from the seat areas.

- The flushing action is achieved as the compressed purge media is released to become the flush media when the plug unseats.
- As the valve rotates 90°, the process media remains away from the seats and in the process.
- The additional benefit of lifting the plug is the low friction and low torque required to cycle the valve.

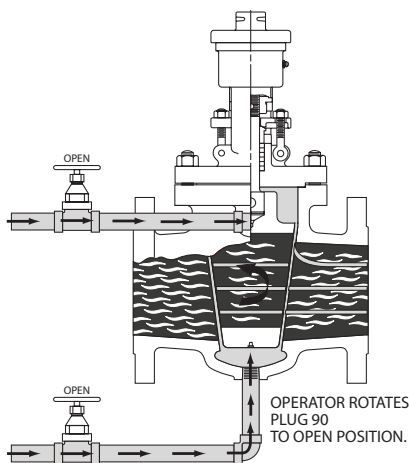

As the plug rotates, the flush is continuously fed through the two purge/flush feed lines.

Points to note:

- This note is going to be missed. This is not a notes section but a demonstration of the purge ports.

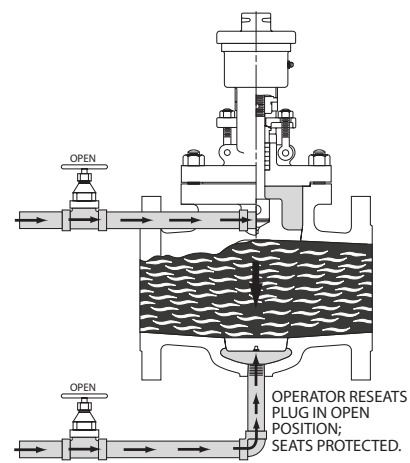

The plug is seated in the open position with the seats once again protected.

- Seating the plug automatically stops the purging process, creating a purge seal or barrier in the upper and lower portion of the valve.

Materials of Construction

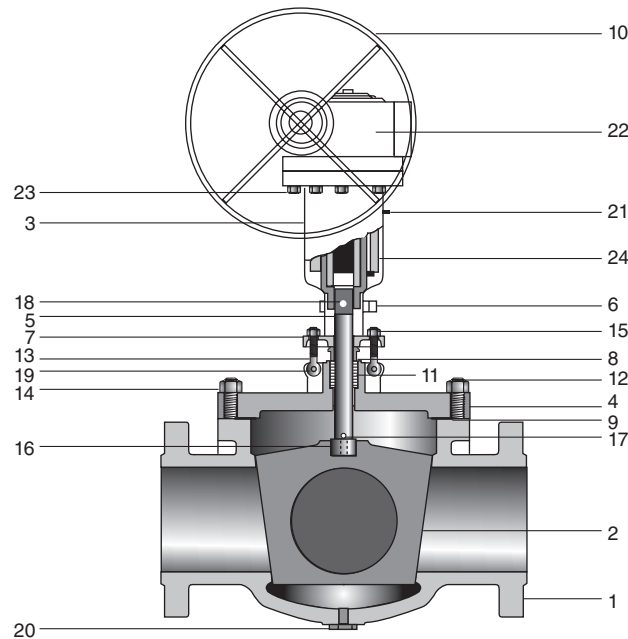

Note:
WEDGEPLUG™ Metal Seated Valves from PACIFIC VALVES® intent is to show typical materials of construction. Materials are subject to change without notice and without obligations. Other material and combinations are available upon request.

Carbon Steel

ITEM	DESCRIPTION	ASTM SPEC
1	Body with optional hardfacing	A-216 Grade WCB
2	Plug (Hardened)	A-217 Grade C12
3	Yoke	Carbon Steel
4	Bonnet	A-216 Grade WCB
5	Stem	A-276 Type 410
6	Position Indicator	Steel
7	Pkg. Gland Flg.	A-216 Grade WCB
8	Pkg. Gland	A-395 Ductile
9	Gasket Bonnet	Steel
10	Handwheel	Steel
11	*Packing	Graphoil
12	Bonnet Stud	A-193 Grade B7
13	Eyebolts	A-307 Grade A
14	Nut, Bonnet Stud	A-194 Grade 2H
15	Nut, Packing Gland Flange	A-563 Grade A
16	Plug Key	A-276 Type 410
17	Plug Key Retainer	A-276 Type 410
18	Keeper Pin, Indicator	Steel
19	Keeper Pin, Eyebolt	Steel
20	Pipe Plug	Carbon Steel
21	Lubricating Fitting	Steel
22	Gear Housing (AUMA)	
23	Cap Screw, Gear Housing	A-307 Grade A
24	Wedgetorque™ Operator	

316 Stainless

ITEM	ASTM SPEC
1	A-351 Grade CF8M
2	Stellite
3	Carbon Steel
4	A-351 Grade CF8M
5	A-276 Type 316
6	Steel
7	A-216 Grade WCB
8	A-395 Ductile
9	A-276 Type 316
10	Steel
11	Graphoil
12	A-193 Grade B8M
13	A-307 Grade A
14	A-194 Grade 8M
15	A-563 Grade A
16	A-276 Type 316
17	A-276 Type 316
18	Steel
19	Steel
20	A-276 Type 316
21	Steel
22	
23	A-307 Grade A
24	

5Cr (A-217 C5)

ITEM	ASTM SPEC
1	A-217 Grade C5
2	A-217 Grade C12
3	Carbon Steel
4	A-217 Grade C5
5	A-276 Type 410
6	Steel
7	A-216 Grade WCB
8	A-395 Ductile
9	A-276 Type 410
10	Steel
11	Graphoil
12	A-193 Grade B16
13	A-307 Grade A
14	A-194 Grade 4
15	A-563 Grade A
16	A-276 Type 410
17	A-276 Type 410
18	Steel
19	Steel
20	A-276 Type 410
21	Steel
22	
23	A-307 Grade A
24	

9Cr (A-217 C12)

ITEM	ASTM SPEC
1	A-217 Grade C12
2	A-217 Grade C12
3	Carbon Steel
4	A-217 Grade C12
5	A-276 Type 410
6	Steel
7	A-216 Grade WCB
8	A-395 Ductile
9	A-276 Type 410
10	Steel
11	Graphoil
12	A-193 Grade B16
13	A-193 Grade B7
14	A-194 Grade 4
15	A-563 Grade A
16	A-276 Type 410
17	A-276 Type 410
18	Steel
19	Steel
20	A-276 Type 410
21	Steel
22	
23	A-307 Grade A
24	

*Standard packing is recommended for most applications to 850°F (455°C). However, in certain applications it may be necessary to use special high temperature packing. Please consult factory when ordering.

CRANE[®]

CRANE CHEMPHARMA & ENERGY

4526 Research Forest Drive
Suite 400
The Woodlands, Texas 77381
U.S.A.
Tel.: (1) 936-271-6500

Xomox Chihuahua, S.A.
Juan Ruiz de Alarcón 313,
Complejo Industrial Chihuahua,
31136 Chihuahua
Mexico
Tel: +52 614 442 9860

Crane Company, and its subsidiaries cannot accept responsibility for possible errors in catalogues, brochures, other printed materials, and website information. Crane Company reserves the right to alter its products without notice, including products already on order provided that such alteration can be made without changes being necessary in specifications already agreed. All trademarks in this material are the property of the Crane Company or its subsidiaries. The Crane and Crane brands logotype (ALOYCO[®], BAUM[®], CENTER LINE[®], CRANE[®], CRYOFLO[®], DEPA[®] & ELRO[®], DOPAK[®], DUO-CHEK[®], FLOWSEAL[®], GYROLOK[®], GO REGULATOR[®], HOKE[®], JENKINS[®], KROMBACH[®], NOZ-CHEK[®], PACIFIC VALVES[®], RESISTOFLEX[®], REVO[®], SAUNDERS[®], STOCKHAM[®], TEXAS SAMPLING[®], WESTLOCK CONTROLS[®], WTA[®], and XOMOX[®]) are registered trademarks of Crane Co. All rights reserved.