



brands you trust.

TECHNICAL DATASHEET
PACIFIC VALVES®
Forged Pressure Seal Valves



Crane ChemPharma & Energy

www.cranecpe.com



Index

Gate Valves.....	3
Parallel Disc Gate Valve	4
Wedge Gate Valve.....	5
Technical Data	6-7
Y-Globe Non-Return Stop Check Valve.....	8
Technical Data	9
Swing Check Valve.....	10
Technical Data	11

Overview Gate Valves

Selection

TYPE AND SIZE – Select the best type of valve for the intended service (gate, globe, or check). Gate and globe valves are available with a selection of wedge or disc and body configurations for different services. Valves may be sized to match existing lines, but they should also be sized according to flow conditions for maximum service life.

RATINGS – Valves must only be used in design conditions within the appropriate ASME pressure-temperature ratings for valve class and body/bonnet material (see Technical Data section).

TEMPERATURE LIMITATIONS – Only use valves within the temperature limitations of their construction. Temperature limitations of body/bonnet materials, trim, bolting and packing, and gaskets must all be considered. Special construction for extended service temperatures are available by application.

MATERIAL AND SERVICE – Pressure Seal valves are available in a variety of body/bonnet materials and trims. Specified materials should be compatible with the service.

Gate Valves

1. Gate valves are normally used for on-off service. They are not recommended for throttling service.
2. Gate valves are normally installed in horizontal pipe runs with the valve stem vertically up. They can also be installed in vertical or horizontal pipe runs with the valve stem other than vertical, but special construction may be required depending on valve size, service conditions and material. When purchasing valves for other than the normal installation, valve orientation should be specified when consulting the factory.
3. After closing a wedge gate valve with sufficient force to develop shutoff, the stem should be backed off slightly ($1/8$ to $1/4$ turn) to relieve stem load. This will enable the stem to expand slightly without bending or damaging the valve and will not affect valve shutoff.
4. Gate valves are offered in two designs: Parallel Disc and Flexible Wedge. Parallel Disc are position seated; Flexible Wedge are torque seated when closing.
5. Can be installed bidirectionally.

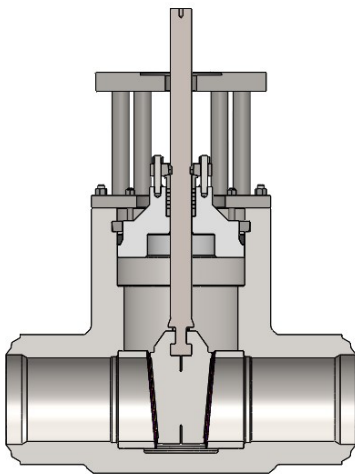

Wedge Gate Valve

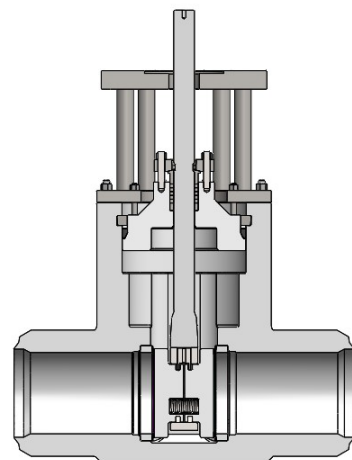

Parallel Disc Gate Valve



Overview Parallel Disc Gate Valve

STEM

The new T-head design allows the carrier assembly to self-align, provides additional strength, and reduces the possibility of a bent stem.

PRESSURE SEAL

Uncomplicated design has segmented retaining ring and graphite/SS Caps* gasket to aid disassembly and provide maximum bonnet seal.

SEAT

Fully encapsulated seats to avoid delamination, same as our cast design. Welded-in seat rings are perpendicular to the flow bore for easy maintenance.

LARGE BW ENDS

Match two different OD

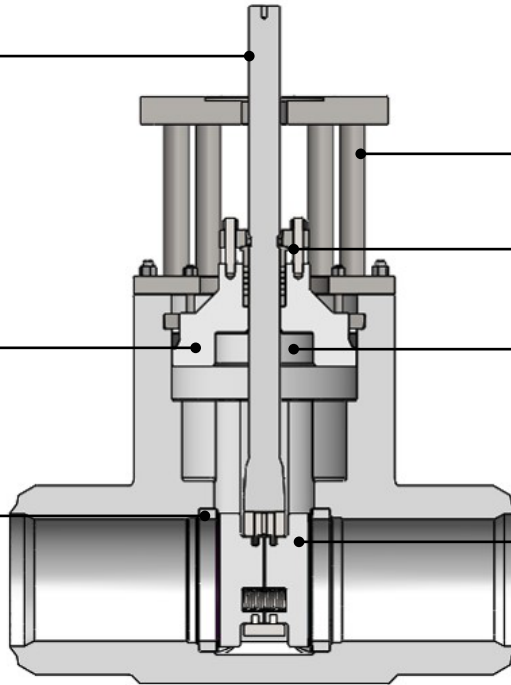

*ACTUATORS

Valves can be supplied with any type of electric, hydraulic, or pneumatic actuator. Standard manual handwheels on valves 12" and smaller with 14" and larger bevel gear operated.

YOKE

Fully fabricated yoke is seismically qualified while offering easy maintenance and actuator mounting.

GLAND

Two piece, self-aligning gland eliminates cocking.

INTEGRAL BACKSEAT

Hard faced for maximum life.

DISCS

Spring-loaded discs are self-aligning and reduce actuator torque requirements.

FULLY GUIDED WEDGES & DISCS

Ensure positive shut-off in both horizontal & vertical orientation, reduction of currently known field failures

Pacific Valve offers Graphite/SS Capsulated Pressure Seal Bonnet Gaskets as a standard, Mild Steel Silver Plated Pressure Seal Bonnet Gaskets are available on request.

Parallel Seat Gate Valve

Parallel seat gate and seat ring construction can be furnished for high differential pressure services or where high piping loads or thermal expansion may cause sticking of a wedge type gate. The parallel seat gate assembly consists of two interchangeable spring-loaded discs, a fully guided disc carrier, and retaining pins.

Position seating eliminates stress and potential binding due to thermal expansion of the stem. Spring-loaded discs help maintain contact between the discs and seat rings during initial sealing and eliminate vibration. Discs are interchangeable which simplifies in-line maintenance and eliminates the need to custom fit the seats to the discs. Internal stops provide positive over travel protection for power actuated valves and act as a reference to position the discs in the open and closed positions. This design features low seating torque which reduces actuator size and cost. Hard faced seating surfaces provide high cycle capability in very high differential pressure services.

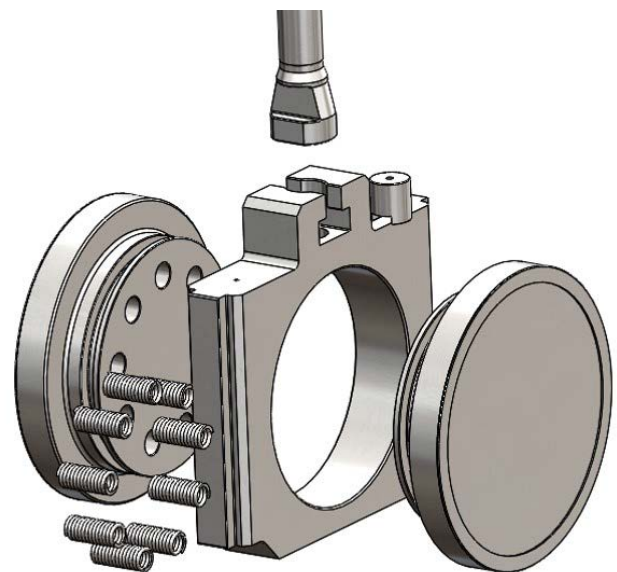



Overview Wedge Gate Valve

STEM

The new T-head design allows the carrier assembly to self-align, provides additional strength, and reduces the possibility of a bent stem.

PRESSURE SEAL

Uncomplicated design has segmented retaining ring and graphite/SS Caps* gasket to aid disassembly and provide maximum bonnet seal.

SEAT RING

Hard faced seat rings are welded to body. Tapered design provides unobstructed flow path.

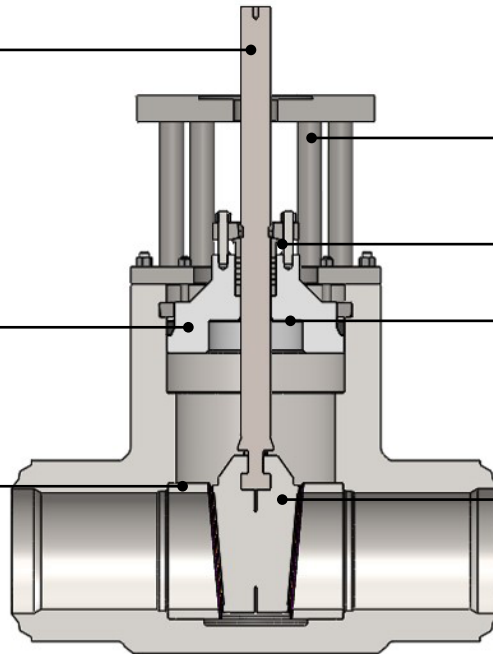

ACTUATORS

Valves can be supplied with any type of electric, hydraulic, or pneumatic actuator. Standard manual handwheels on valves 12" and smaller with 14" and larger bevel gear operated.

YOKE

Fully fabricated yoke is seismically qualified while offering easy maintenance and actuator mounting.

GLAND

Two piece, self-aligning gland eliminates cocking.

INTEGRAL BACKSEAT

Hard faced for maximum life.

WEDGE

One-piece, flexible wedge is fully guided, resists sticking or binding due to thermal expansion, has hardfaced seating surfaces for long life. Parallel seat or solid wedge also available.

FULLY GUIDED WEDGES/DISCS

Ensure positive shut-off in both horizontal & vertical orientation, reduction of currently known field failures

*Pacific Valve® offers Graphite/SS Capsulated Pressure Seal Bonnet Gaskets as a standard, Mild Steel Silver Plated Pressure Seal Bonnet Gaskets are available on request.

Flexible Wedge

The flex wedge is a one piece, fully guided wedge with a central hub to allow the seating faces to move relative to each other thus compensating for distortion of the body seats due to thermal expansion or piping loads. Seat ring and wedge seating surfaces are set on a 5 degree angle from vertical to minimize sliding contact of the wedge and seat ring during opening and closing. Wedging actions help affect a tight seal in low differential pressure services. Flexible wedge construction resists wedge sticking or binding in services where the valve may be closed when hot and opened when cold. Seating surfaces are hard faced to provide high cycle capability in very high differential pressure services.





Technical Data Parallel Disc Gate Valve

Dimensions & Weights

#600					
Valve Size	ASME Short Pattern	Weight	Custom Short End	Weight	H
12"	NA	-	NA	-	-
14"	NA	-	NA	-	-
16"	NA	-	NA	-	-
18"	NA	-	NA	-	-
20"	47.00"	6250.00	32.75"	5578	60.94"
22"	NA	-	36.25"	7598	68.00"
24"	55.00"	10548.00	42.50"	9798	72.72"
26"	NA	-	41.25"	10845	77.64"
28"	NA	-	43.75"	13807	84.92"
30"	NA	-	46.45"	15945	87.26"
#1500					
12"	39.00"	3030	27.00"	2703	43.99"
14"	42.00"	3615	27.00"	3113	46.22"
16"	47.00"	4866	29.50"	4142	51.46"
18"	53.00"	6536	32.50"	5508	57.25"
20"	NA	-	NA	-	-
22"	NA	-	NA	-	-
24"	NA	-	NA	-	-
26"	NA	-	NA	-	-
28"	NA	-	NA	-	-
30"	NA	-	NA	-	-
#2500					
12"	41.00"	3545	27.75"	3147	39.4"
14"	44.00"	4967	32.50"	4500	46.4"
16"	49.00"	6410	35.25"	5726	48.5"
18"	55.00"	8541	36.50"	7402	54.2"
20"	NA	-	NA	-	-
22"	NA	-	NA	-	-
24"	NA	-	NA	-	-
26"	NA	-	NA	-	-
28"	NA	-	NA	-	-
30"	NA	-	NA	-	-

Dimensions in inches, weights in pounds

Note: L : End to End Dimension
H : Distance from Valve center to valve cap high point.

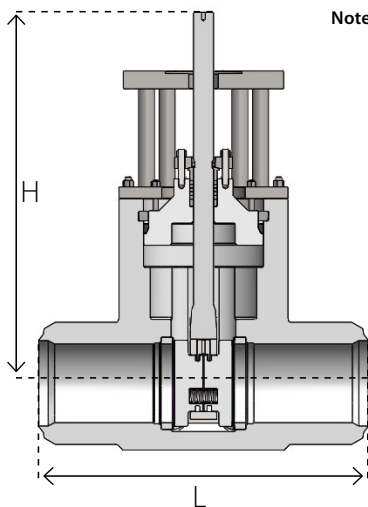

Materials of Construction

Part Description	Material
BODY	ASTM A182 GR F91
BONNET	ASTM A182 GR F91
DISC	ASTM A182 GR F91+STELLITE 6
DISC CARRIER	ASTM A182 GR F91
CLIP	11-13% CR
SPRING	INCONEL
SEAT RING	ASTM A182 GR F91+STELLITE 6
THRUST RING	AISI 4340 OR 4140
GLAND	11-13% CR
JUNK RING	11-13% CR
STEM	ASTM A182 F6A
GLAND FLANGE	ASTM A515 GR 70
SEGMENT RING	AISI 4140
BONNET CARRIER	ASTM A515 GR 70
STUD (BONNET-BONNET CARRIER JOINT)	ASTM A193 GR B7
NUT (BONNET-BONNET CARRIER JOINT)	ASTM A194 GR 2H
COLUMN PIPE	CARON STEEL
STUD (BONNET CARRIER-COLUMN JOINT)	ASTM A193 GR B7
NUT (BONNET CARRIER-COLUMN JOINT)	ASTM A194 GR 2H
PACKING	GRAPHITE
STUD (BODY-BONNET CARRIER JOINT)	ASTM A193 GR B7
NUT (BODY-BONNET CARRIER JOINT)	ASTM A194 GR 2H
STUD (BONNET - GLAND FLANGE JOINT)	ASTM A193 GR B7
NUT (BONNET - GLAND FLANGE JOINT)	ASTM A194 GR 2H
GASKET	GRAPHITE WITH SS CAPS
ADAPTER PLATE MACHINING	ASTM A515 GR 70
BYPASS VALVE	ASTM A182 GR F91
PIPE FOR BYPASS	ASTM A335 P91
ELBOW FOR BYPASS	ASTM A182 GR F91
T FITTING FOR BYPASS	ASTM A182 GR F91
HEX HEAD CAP SCREW, ACTUATOR	MFG STD
AIR WRENCH ADAPTER FOR GEAR BOX	MFG STD

Cv Values

12"	#1500	6570
14"	#1500	7890
16"	#1500	10325
18"	#1500	13425
12"	#2500	4535
14"	#2500	5500
16"	#2500	7210
18"	#2500	9215
20"	#2500	11450
20"	#600	20950
22"	#600	25278
24"	#600	30850
26"	#600	36796
28"	#600	42398
30"	#600	48873



Technical Data Wedge Gate Valve

Dimensions & Weights

#1500			
Valve Size	Custom Short End	H	Weight
12"	27.00"	43.65"	2707
14"	NA	-	-
16"	NA	-	-
18"	NA	-	-
20"	NA	-	-
#2500			
12"	NA	-	-
14"	32.50"	46.17"	4538
16"	35.25"	47.75"	5665
18"	38.50"	53.3"	7442
20"	43.50"	57.5"	10665

Dimensions in inches, weights in pounds

Note: L : End to End Dimension
H : Distance from Valve center to valve cap high point.

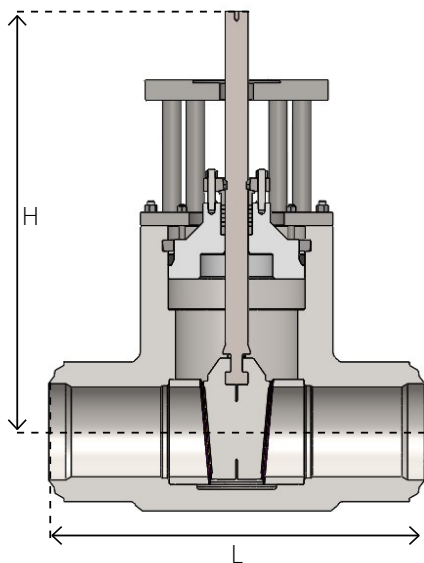

Materials of Construction

Part Description	Material
BODY	"15NiCuMoNb5 1.6368(WB 36)"
BONNET	15NiCuMoNb5 1.6368(WB 36)
WEDGE	15NiCuMoNb5 1.6368(WB 36)+STELLITE 6
SEAT RING	15NiCuMoNb5 1.6368(WB 36)+STELLITE 6
THRUST RING	AISI 4340 OR 4140
GLAND	11-13% CR
JUNK RING	11-13% CR
STEM	ASTM A182 F6A
GLAND FLANGE	ASTM A515 GR 70
SEGMENT RING	AISI 4140
BONNET CARRIER	ASTM A515 GR 70
STUD (BONNET-BONNET CARRIER JOINT)	ASTM A193 GR B7
NUT (BONNET-BONNET CARRIER JOINT)	ASTM A194 GR 2H
COLUMN PIPE	CARON STEEL
STUD (BONNET CARRIER-COLUMN JOINT)	ASTM A193 GR B7
NUT (BONNET CARRIER-COLUMN JOINT)	ASTM A194 GR 2H
PACKING	GRAPHITE
STUD (BODY-BONNET CARRIER JOINT)	ASTM A193 GR B7
NUT (BODY-BONNET CARRIER JOINT)	ASTM A194 GR 2H
STUD (BONNET - GLAND FLANGE JOINT)	ASTM A193 GR B7
NUT (BONNET - GLAND FLANGE JOINT)	ASTM A194 GR 2H
GASKET	GRAPHITE WITH SS CAPS
ADAPTER PLATE MACHINING	ASTM A515 GR 70
BYPASS VALVE	ASTM 182 F22
PIPE FOR BYPASS	ASTM A335 P22
ELBOW FOR BYPASS	ASTM 182 F22
T FITTING FOR BYPASS	ASTM 182 F22
HEX HEAD CAP SCREW, ACTUATOR	MFG STD
AIR WRENCH ADAPTER FOR GEAR BOX	MFG STD



Overview Y-Globe Non-Return Stop Check Valve

Y-Globe Non-Return Stop-Check Valves*

1. Globe valves are normally installed with flow and pressure under the disc. Always consult with the factory before installing valves with flow in the other direction. Under certain service conditions or when valves are equipped with cylinders or electric motor actuators, there may be a cost advantage in designing and installing the valves with flow over the disc. If actuators are sized for these conditions, care must be taken to assure valves are installed correctly.
2. Globe valves are suitable for most throttling applications; however, they should not be used for throttling at less than 10-20% open. This can cause excessive vibration, noise, and damage to disc and seats. Use of smaller valves with lower flow capacity may permit the valve to be open a greater percentage, thus avoiding damage. Continuous severe throttling applications may require a control valve.
3. Non-return (Stop-Check) valves provide the same function as a globe valve with the addition of providing piston-lift-check valve protection in the event of backflow. The valve stem is not connected to the disc, and when the stem is in the open position then the disc is free to respond to the flow.

*ACTUATION

Can be supplied with a hammerblow handwheel, manual gear set, electric motor operator, pneumatic, or hydraulic cylinder operator

STEM

Stainless steel stem is precision ground for minimal packing friction during operation.

STEM GUIDE

Acts as anti-rotating device for the stem.

YOKE

Designed to withstand seismic activities, the fully fabricated yoke features hassle-free assembly/ disassembly of topworks and simple actuator mounting.

INTEGRAL BACKSEAT

Hard faced for maximum life.

BODY

Streamlined flow path demonstrating high Cv factors which minimize pressure drop across a given system.

LARGE BW ENDS

To match two different outside diameters

BALANCED PLUG/DISC

With internal pressure self-relieving device (no external equalizing by-pass)

*Pacific Valve® offers Graphite/SS Capsulated Pressure Seal Bonnet Gaskets as a standard, Mild Steel Silver Plated Pressure Seal Bonnet Gaskets are available on request.

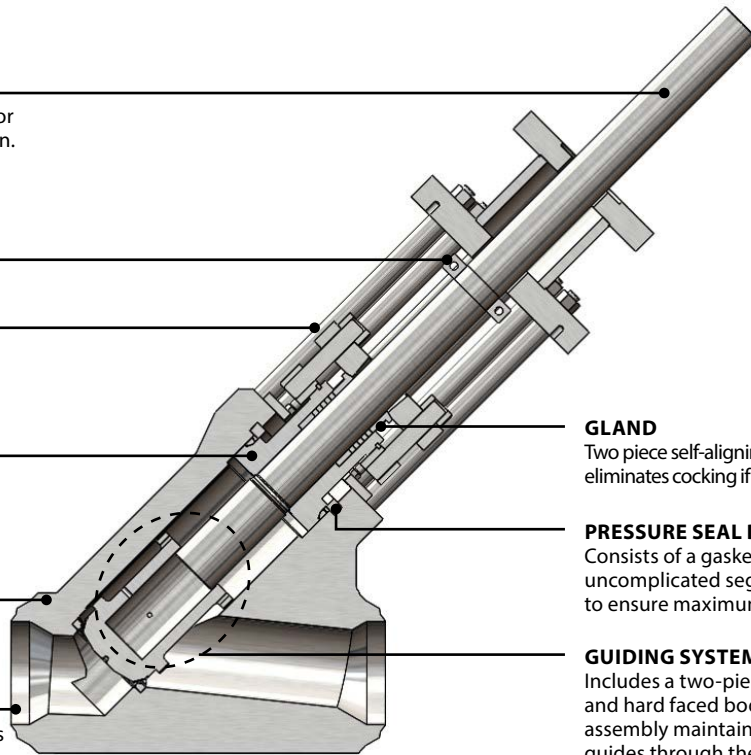

GLAND

Two piece self-aligning gland and gland flange eliminates cocking if packing adjustment is required.

PRESSURE SEAL DESIGN

Consists of a gasket, thrust ring and uncomplicated segmented retaining rings to ensure maximum bonnet seal*. *

GUIDING SYSTEM

Includes a two-piece disc assembly and hard faced body guides. The disc assembly maintains contact with the guides through the full valve stroke.

SEATING SURFACE

The disc and body seating surfaces are hard faced for extended service.

*For maximum reliability, it is recommended that Pacific Valves® Y-Globes Stop Check Valves be installed with flow axis horizontal and with bonnet above the valve in a vertical plane. Please consult factory for further details.



Technical Data Y-Globe Non-Return Stop Check Valve

Materials of Construction

Part Description	Material
BODY	ASTM A182 GR F91
BONNET	ASTM A182 GR F91
DISC	ASTM A182 GR F91 + OVERLAY ALLOY 21
SEAT RING	ASTM A182 GR F91 + OVERLAY ALLOY 21
THRUST RING	AISI 4340 OR 4140
GLAND	11-13% CR
JUNK RING	11-13% CR
STEM	ASTM A182 F6A
GLAND FLANGE	ASTM A515 GR 70
SEGMENT RING	AISI 4140
BONNET CARRIER	ASTM A515 GR 70
PACKING	GRAPHITE
STUD (BODY-YOKE BOTTOM PLATE JOINT)	ASTM A193 GR B7
NUT (BODY-YOKE BOTTOM PLATE JOINT)	ASTM A194 GR 2H
STUD (BONNET - GLAND FLANGE JOINT)	ASTM A193 GR B7
NUT (BONNET - GLAND FLANGE JOINT)	ASTM A194 GR 2H
GASKET	GRAPHITE WITH SS CAPS
ADAPTER PLATE MACHINING	ASTM A515 GR 70
RETAINER RING	AISI 4340 OR 4140
BONNET COLLAR	ASTM A515 GR 70
YOKE BOTTOM PLATE	CARON STEEL(ASTM A36)
YOKE TOP PLATE	CARON STEEL(ASTM A36)
YOKE PIPE	CARON STEEL(ASTM A105)
STEM GUIDE	ASTM A515 GR 70
HEX HEAD CAP SCREW-UPPPER ADAPTER PLATE	ASTM A193 GR B7
JACK SCREW	ASTM A193 GR B7
KEY (STEM GUIDE)	11-13 % CR
STUD (STEM GUIDE JOINT)	ASTM A193 GR B7
NUT (STEM GUIDE JOINT)	ASTM A194 GR 2H
BYPASS VALVE	ASTM A182 GR F91
PIPE FOR BYPASS	ASTM A335 P91
ELBOW FOR BYPASS	ASTM A182 GR F91
T FITTING FOR BYPASS	ASTM A182 GR F91
HEX HEAD CAP SCREW, ACTUATOR	MFG STD
AIR WRENCH ADAPTER FOR GEAR BOX	MFG STD

Cv Values

12"	#1500	2771
14"	#1500	3332
16"	#1500	4527
18"	#1500	5727
12"	#2500	1913
14"	#2500	2323
16"	#2500	3170
18"	#2500	4023

Dimensions & Weights

#1500				
Valve Size	ASME Short Pattern	Custom Short End	H	Weight
12"	39.00"	NA	63.34"	4063
14"	42.00"	NA	66.16"	5040
16"	47.00"	NA	74.1"	7165
18"	NA	50.00"	81.83"	9386
#2500				
12"	41.00"	NA	59.85"	4624
14"	NA	40.50"	72.07"	6914
16"	NA	43.50"	72.10"	7678
18"	NA	47.50"	76.55"	10014

Dimensions in inches, weights in pounds

Note: L : End to End Dimension

H : Distance from Valve center to valve cap high point.

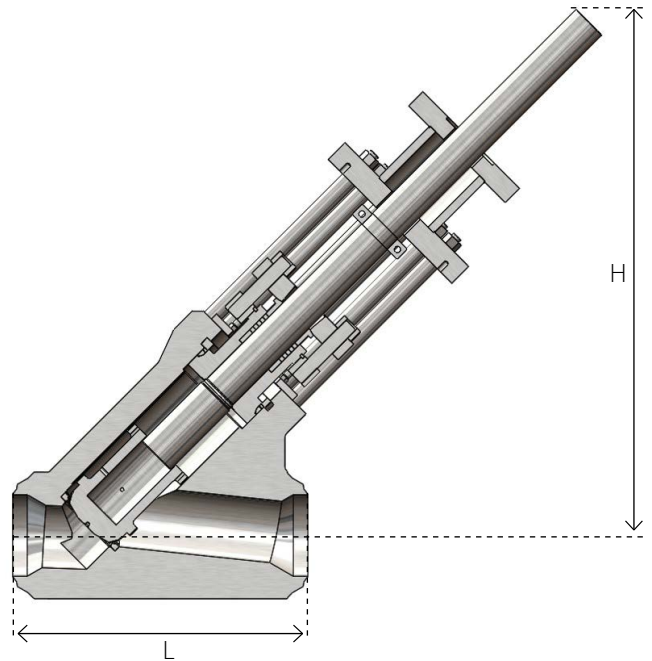



Overview Swing Check Valves

Check Valves

Highly Efficient

The self-aligning disc-hinge assembly and tapered seat ring allow sealing in no-flow conditions and/or in the case of flow reversal. The advantage of this design is flow is only permitted in one direction to protect major plant equipment, as well as minimizing backflow during seating of the disc.

Tight Shutoff

Spherical profile of the disc mounting arm allows for the disc to pivot about the hinge bore so that the disc is consistently aligned with the seat to provide exceptionally tight shutoff, and ensures the disc is always seated in no-flow conditions.

General Design Features

Long Life

The positive internal disc stop is an integral part of the body casting, providing a robust stopping point of the disc to prevent fluttering. Hardfaced seating surfaces prolong the life of the disc by reducing wear during normal operation where the disc can experience higher impacts due to the pendulum effect.

Internal Disc Hanger

Having the disc internally hinge eliminates body wall penetrations. The unique Pacific swing check valve not only eliminates potential leakage through external hinge pins, but the disc-hinge assembly is designed for ease of maintenance, by having only two bolts in the disc bracket that allow full removal of the disc-hinge assembly.

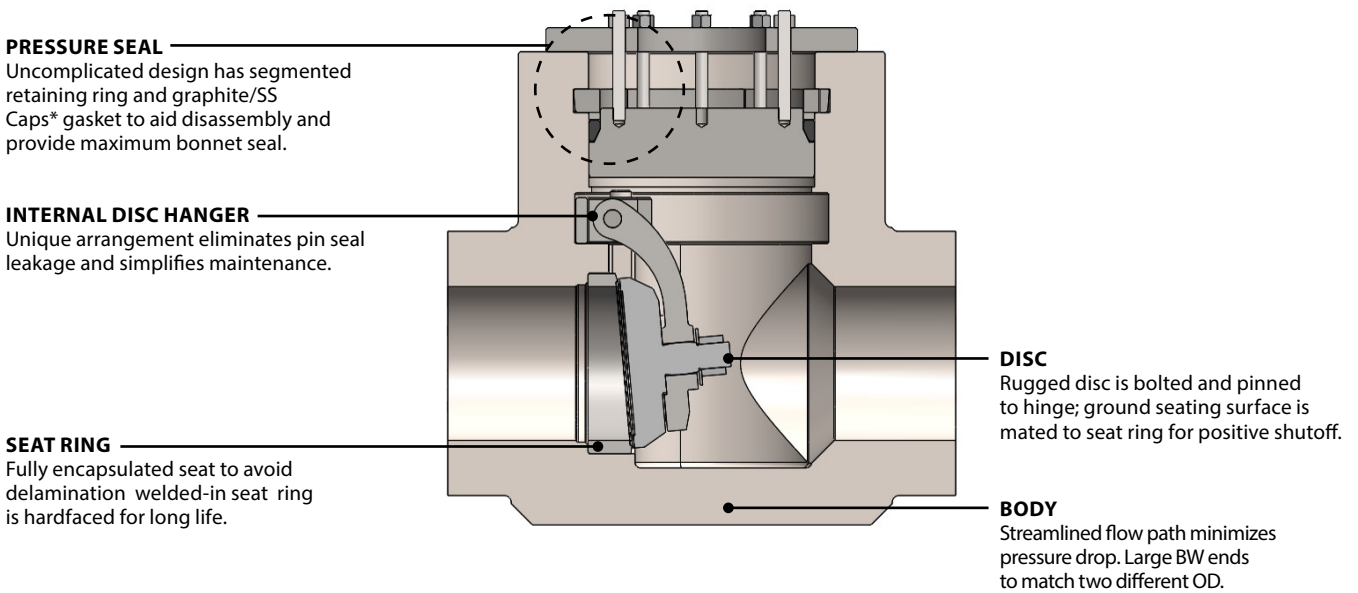

Swing Check Valve

PACIFIC VALVES® CODES AND STANDARDS:

Years of research and development, together with practical experience in reconditioning all types of valves, have gone into the design and manufacture of Pacific Valves®. High quality material and workmanship, combined with the modern manufacturing methods used in producing these valves, is your assurance of a dependable, uniform product. Pacific Valves® are designed in accordance with applicable requirements of the latest edition of the following standards.

- API – American Petroleum Institute
- MSS – Manufacturers' Standardization Society of the Valve and Fittings Industry
- ASME – American Society of Mechanical Engineers



Technical Data Swing Check Valves

Dimensions & Weights

#1500			
Valve Size	Custom Short End	H	Weight
12"	26.75"	17.81"	1878
14"	NA	-	-
16"	NA	-	-
18"	NA	-	-
20"	NA	-	-
#2500			
12"	NA	-	-
14"	30.00"	22.08"	3209
16"	36.00"	24.9"	4937
18"	39.00"	30.29"	7213
20"	43.75"	29.11"	8696

Dimensions in inches, weights in pounds

Note: L : End to End Dimension
H : Distance from Valve center to valve cap high point.

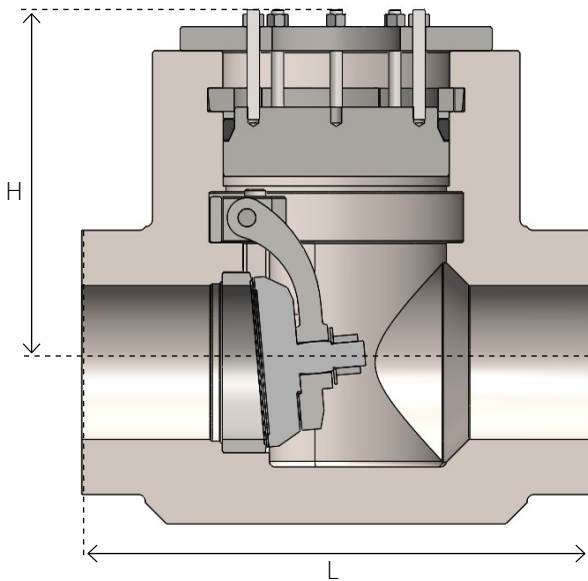

Materials of Construction

Part Description	Material
BODY MACHINED	"15NiCuMoNb5 1.6368(WB 36)"
BODY PRE-MACHINED	"15NiCuMoNb5 1.6368(WB 36)"
COVER/BONNET	"15NiCuMoNb5 1.6368(WB 36)"
DISC MACHINED + OVERLAY	15NiCuMoNb5 1.6368(WB 36) + Stellite 6
SEAT RING MACHINED + OVERLAY	15NiCuMoNb5 1.6368(WB 36)+ Stellite 6
THRUST RING	AISI 4340 OR 4140
SEGMENT RING	AISI 4140
BONNET CARRIER	ASTM A515 GR 70
GASKET	GRAPHITE WITH SS CAPS
SPLIT PIN	STEEL
DISC NUT	ASTM A194 GR 2H
WASHER	STEEL
SOCKET HEADED CAP SCREW	ASTM A193 GR B7
HINGE CASTING	ASTM A217 GR WC6
HINGE MACHINING	ASTM A217 GR WC6
HINGE BRACKET	"15NiCuMoNb5 1.6368(WB 36)"
HINGE PIN	"X39CrMo17-1 1.4122"
STUD (BONNET - BONNET CARRIER JOINT)	ASTM A193 GR B7
NUT (BONNET - BONNET CARRIER JOINT)	ASTM A194 GR 2H

Cv Values

12"	#1500	3864
14"	#2500	3158
16"	#2500	3717
18"	#2500	5100
20"	#2500	6240



Crane ChemPharma & Energy
 Pacific Valves® Manufacturing Plant
 4444 Cooper Road
 Cincinnati, OH 45242
 Tel.: +1 513-745-6000
 Fax: +1 513-745-6086
 www.cranecpe.com



Crane ChemPharma & Energy
 Pacific Valves® Manufacturing Plant
 Ruiz de Alarcón 313, Complejo
 Industrial Chihuahua, 31000
 Chihuahua, Chih., Mexico
 Tel.: +52 614-442-9860

Crane ChemPharma & Energy
 Global Headquarters
 4526 Research Forest Drive, Suite 400
 The Woodlands, TX 77381
 Tel.: +1 936-271-6500
 Fax: +1 936-271-6510

brands you trust.



COMPAC-NOZ®



DEPA®

ELRO®

DUO-CHEK®



NOZ-CHEK®



RESISTOFLEX®



UNI-CHEK®



XOMOX®

Crane Co., and its subsidiaries cannot accept responsibility for possible errors in catalogues, brochures, other printed materials, and website information. Crane Co. reserves the right to alter its products without notice, including products already on order provided that such alteration can be made without changes being necessary in specifications already agreed. All trademarks in this material are property of the Crane Co. or its subsidiaries. The Crane and Crane brands logotype, in alphabetical order, (ALOYCO®, CENTER LINE®, COMPAC-NOZ®, CRANE®, DEPA®, DUO-CHEK®, ELRO®, FLOWSEAL®, JENKINS®, KROMBACH®, NOZ-CHEK®, PACIFIC VALVES®, RESISTOFLEX®, REVO®, SAUNDERS®, STOCKHAM®, TRIANGLE®, UNI-CHEK®, WTA®, and XOMOX®) are registered trademarks of Crane Co. All rights reserved.