

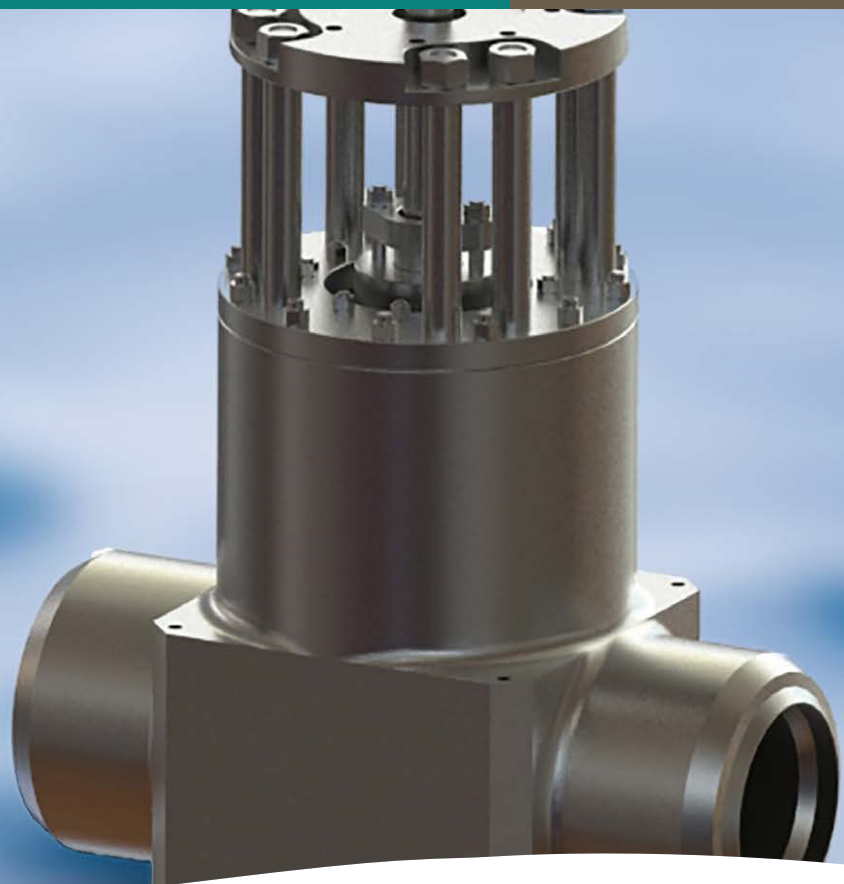

brands you trust.



Crane ChemPharma & Energy

PACIFIC VALVES®
Forged Pressure Seal Valves

www.cranecpe.com



Introduction

About Crane Co.....	3
About Pacific Valves.....	4
Pacific Quality.....	5
Gate Valves.....	6
Parallel Disc Gate Valves.....	7
Wedge Gate Valve.....	8
Y-Globe Non-Return Stop Check Valve.....	9-10
Swing Check Valves.....	11



Key Features

- 1 Body design to minimize creep and fatigue impact for demanding applications
- 2 Fully encapsulated seat rings to minimize hard facing delamination issues, preventing potential damage and unplanned plant shut downs
- 3 One-piece forged solid block design for all sizes

Applications

- Thermal & Cogeneration Power Plant
- Chemical, Petrochemical & Other Industrial Processes



Introduction to Crane • Crane Co.

FOUNDED IN 1855

- 1 FLUID HANDLING
- 2 AEROSPACE & ELECTRONICS
- 3 MERCHANDISING SYSTEMS AND PAYMENT TECHNOLOGIES
- 4 ENGINEERED MATERIALS

Crane Co.

Crane Co. is a diversified global manufacturer of engineered industrial products traded on the New York Stock Exchange (NYSE: CR). One of its segments, Crane Fluid Handling, provides highly engineered products for fluid handling applications worldwide.

The Fluid Handling Segment

Crane Fluid Handling provides highly-engineered products including **valves, pumps, controls and water treatment equipment for fluid handling applications worldwide.** Its operating units include Crane ChemPharma & Energy, Crane Nuclear, Crane Building Services, Crane Pumps & Systems, Crane Supply, Barksdale Control Products.

Crane ChemPharma & Energy (CPE)

Crane CP&E designs and manufactures a variety of high-performance products including: highly-engineered check valves, sleeved plug valves, lined valves, process ball valves, high performance butterfly valves, bellows sealed globe valves, aseptic and industrial diaphragm valves, multi/quarter-turn valves, actuation, sight glasses, lined pipe, fitting and hoses, and air-operated diaphragm and peristaltic pumps. Its trusted brands are in use worldwide in many industries, including **Oil & Gas, Oil Refining, Petrochemical, Power Generation, Chemical Processing, Biotechnology, and Pharmaceutical.**

Crane (CPE) Brands

ALOYCO • CENTER LINE • COMPAC-NOZ • CRANE • DEPA
DUO-CHEK • ELRO • FLOWSEAL • JENKINS • KROMBACH
NOZ-CHEK • PACIFIC • RESISTOFLEX • REVO • SAUNDERS
STOCKHAM • TRIANGLE • UNI-CHEK • WTA • XOMOX

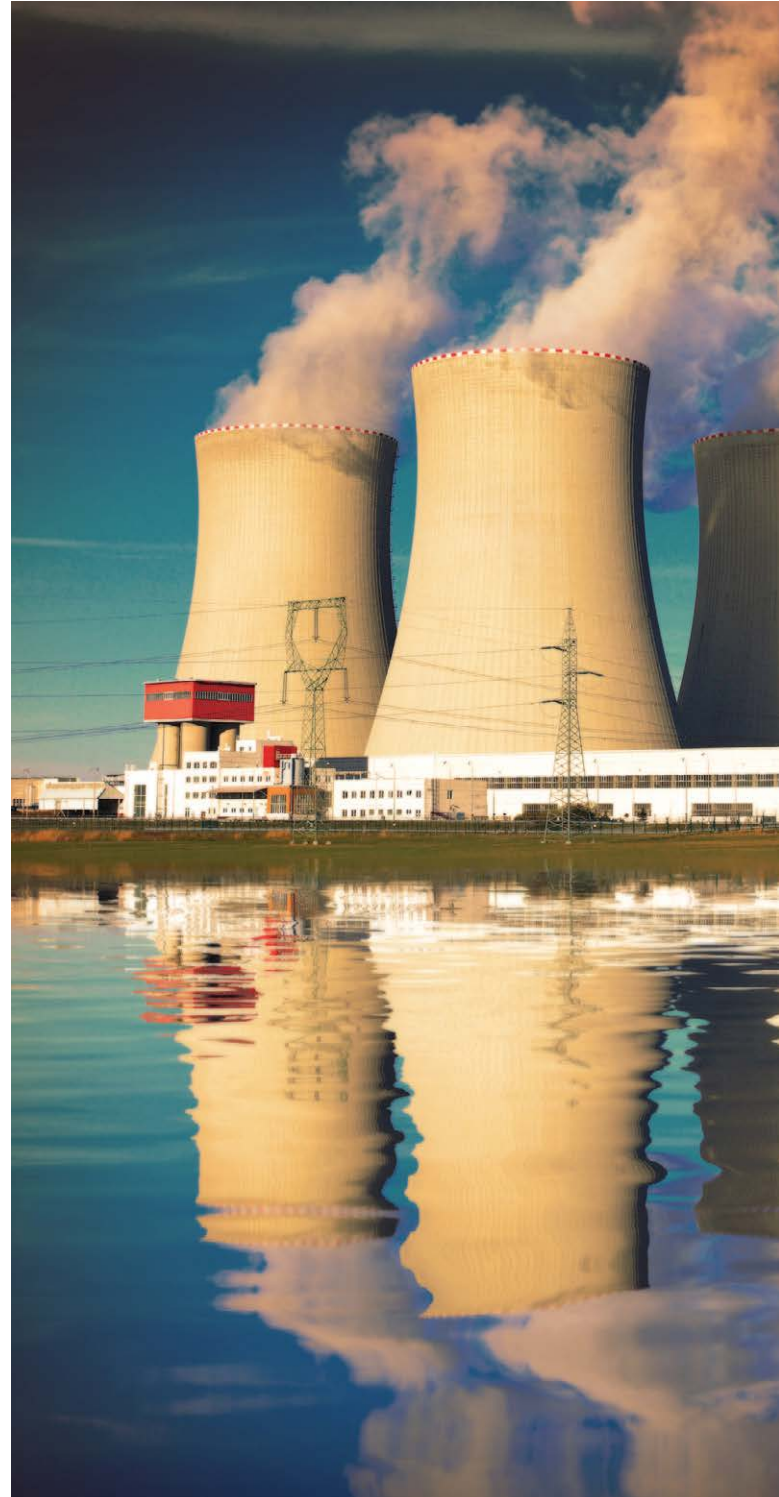



Pacific® Valves

Company History and Introduction

Pacific® Valves was established in Signal Hill, California in 1934, as a company devoted to reconditioning all makes, models, types and sizes of valves. During this time, the manufacturing engineers quickly noticed a pattern of design flaws in the valves that consistently drove repair business. By using this unique experience, Pacific quickly developed its own line

of Gate, Globe and Check valves and we've never looked back. The cornerstones of our success are continuous quality improvement, reliable service and support, and robust investment into product innovation. These are the hallmarks that have enabled Pacific Valves to become one of the most proven and respected brands in the world.

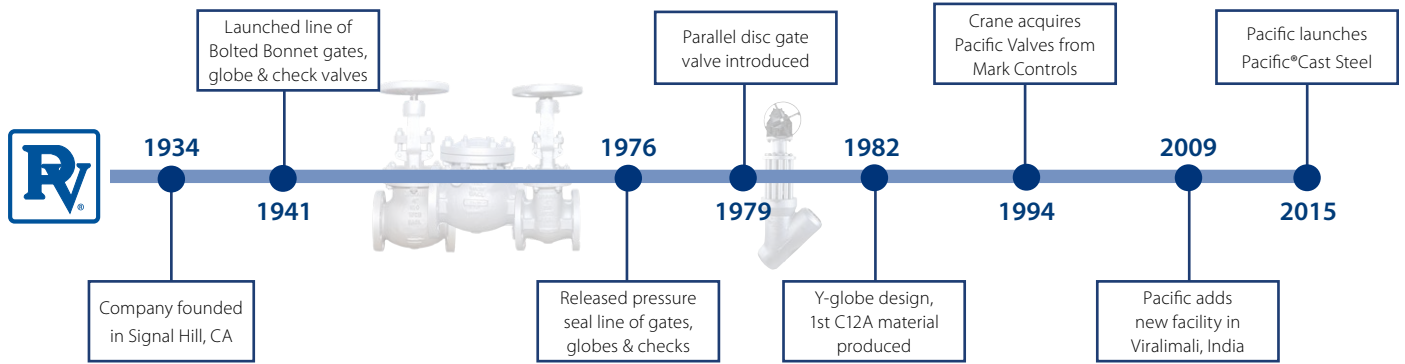

Manufacturing Locations





Pacific Quality

Crane is built on quality principles and practices to achieve the best safety, quality, performance, delivery, service and total cost. As such, all suppliers must abide by the policies set forth in the Crane Global Supplier Quality Manual.

Process-driven Results

Years of research and development, together with practical experience in reconditioning all types of valves, have gone into the design and manufacture of Pacific® Valves. High quality materials and workmanship, combined with the modern manufacturing methods used in producing these valves are your assurance of a dependable, uniform product. Pacific Valves are designed in accordance with the latest editions of industry requirements and design standards.

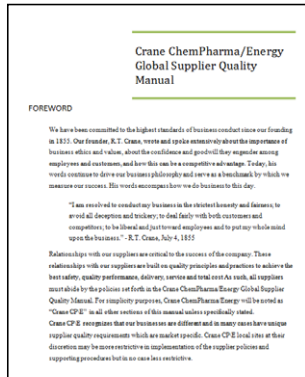

Certified Quality

These valves comply with the applicable requirements of the following standards:

- ASME B 16.34
- ASME B 16.10
- ASME B 16.5
- ASME B 16.25

Crane processes are audited by global customers.

Process Failure Mode Effects Analysis (PFMEA) is a structured tool used to evaluate and document ways in which a product might fail to meet customers' expectations.

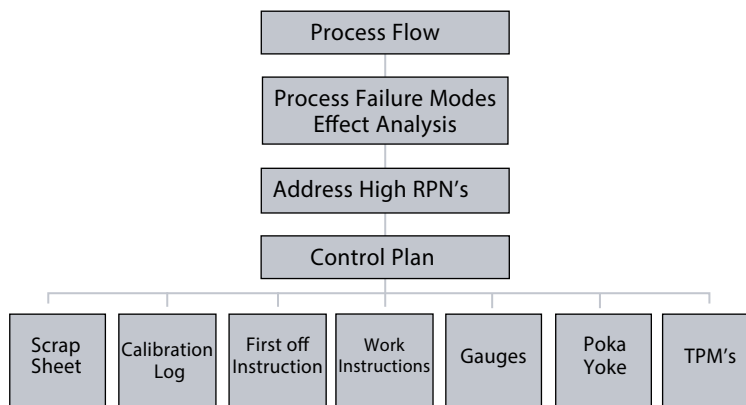

Control Plan Process - Defining expectations before production.

Consistent Quality. Replicable Results.



Overview Gate Valves

Selection

TYPE AND SIZE – Select the best type of valve for the intended service (gate, globe, or check). Gate and globe valves are available with a selection of wedge or disc and body configurations for different services. Valves may be sized to match existing lines, but they should also be sized according to flow conditions for maximum service life.

RATINGS – Valves must only be used in design conditions within the appropriate ASME pressure-temperature ratings for valve class and body/bonnet material (see Technical Data section).

TEMPERATURE LIMITATIONS – Only use valves within the temperature limitations of their construction. Temperature limitations of body/bonnet materials, trim, bolting and packing, and gaskets must all be considered. Special construction for extended service temperatures are available by application.

MATERIAL AND SERVICE – Pressure Seal valves are available in a variety of body/bonnet materials and trims. Specified materials should be compatible with the service.

Gate Valves

1. Gate valves are normally used for on-off service. They are not recommended for throttling service.
2. Gate valves are normally installed in horizontal pipe runs with the valve stem vertically up. They can also be installed in vertical or horizontal pipe runs with the valve stem other than vertical, but special construction may be required depending on valve size, service conditions and material. When purchasing valves for other than the normal installation, valve orientation should be specified when consulting the factory.
3. After closing a gate valve with sufficient force to develop shutoff, the stem should be backed off slightly ($1/8$ to $1/4$ turn) to relieve stem load. This will enable the stem to expand slightly without bending or damaging the valve and will not affect valve shutoff.
4. Gate valves are offered in two designs: Parallel Disc and Flexible Wedge. Parallel Disc are position seated; Flexible Wedge are torque seated when closing.
5. Can be installed bidirectionally

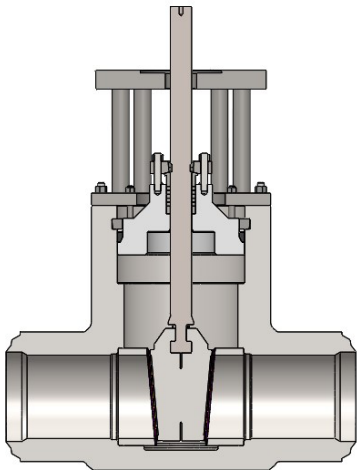

Wedge Gate Valve

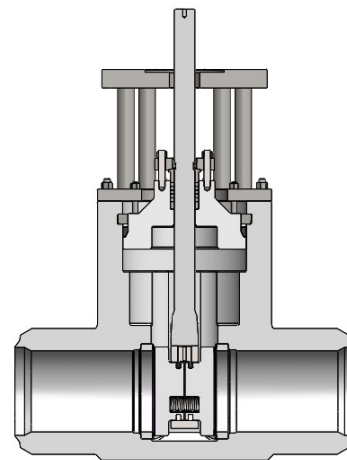

Parallel Disc Gate Valve

Overview Parallel Disc Gate Valve

STEM

The new T-head design allows the carrier assembly to self-align, provides additional strength, and reduces the possibility of a bent stem.

PRESSURE SEAL

Uncomplicated design has segmented retaining ring and graphite/SS Caps* gasket to aid disassembly and provide maximum bonnet seal.

SEAT

Fully encapsulated seats to avoid delamination, same as our cast design. Welded-in seat rings are perpendicular to the flow bore for easy maintenance.

LARGE BW ENDS

Match two different OD

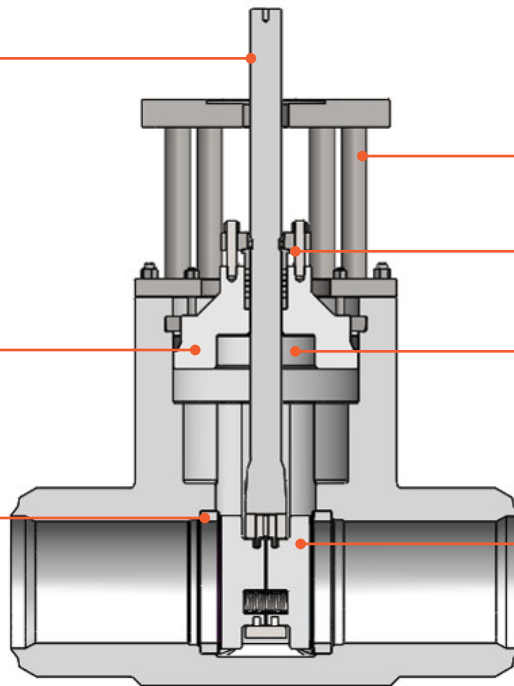

***ACTUATORS**

Valves can be supplied with any type of electric, hydraulic, or pneumatic actuator. Standard manual handwheels on valves 12" and smaller with 14" and larger bevel gear operated.

YOKE

Fully fabricated yoke is seismically qualified while offering easy maintenance and actuator mounting.

GLAND

Two piece, self-aligning gland eliminates cocking.

INTEGRAL BACKSEAT

Hard faced for maximum life.

DISCS

Spring-loaded discs are self-aligning and reduce actuator torque requirements.

FULLY GUIDED WEDGES & DISCS

Ensure positive shut-off in both horizontal & vertical orientation, reduction of currently known field failures

*Pacific Valve® offers Graphite/SS Capsulated Pressure Seal Bonnet Gaskets as a standard, Mild Steel Silver Plated Pressure Seal Bonnet Gaskets are available on request.

Parallel Seat Gate Valve

Parallel seat gate and seat ring construction can be furnished for high differential pressure services or where high piping loads or thermal expansion may cause sticking of a wedge type gate. The parallel seat gate assembly consists of two interchangeable spring-loaded discs, a fully guided disc carrier, and retaining pins.

Position seating eliminates stress and potential binding due to thermal expansion of the stem. Spring-loaded discs help maintain contact between the discs and seat rings during initial sealing and eliminate vibration. Discs are interchangeable which simplifies in-line maintenance and eliminates the need to custom fit the seats to the discs. Internal stops provide positive over travel protection for power actuated valves and act as a reference to position the discs in the open and closed positions. This design features low seating torque which reduces actuator size and cost. Hard faced seating surfaces provide high cycle capability in very high differential pressure services.

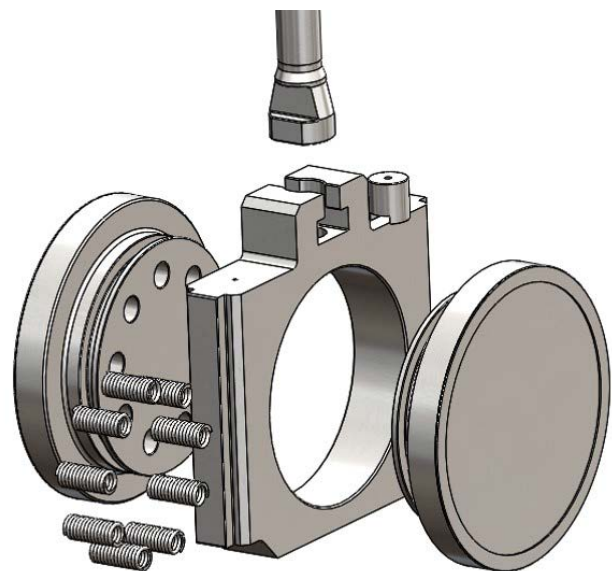



Overview Wedge Gate Valve

STEM

The new T-head design allows the carrier assembly to self-align, provides additional strength, and reduces the possibility of a bent stem.

PRESSURE SEAL

Uncomplicated design has segmented retaining ring and graphite/SS Caps* gasket to aid disassembly and provide maximum bonnet seal.

SEAT RING

Hard faced seat rings are welded to body. Tapered design provides unobstructed flow path.

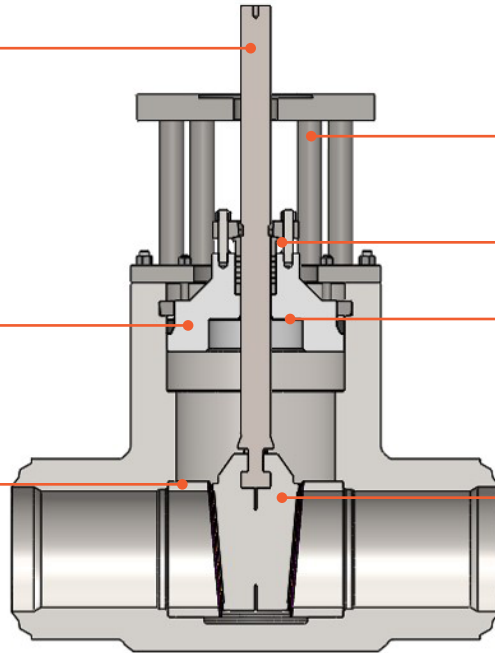

ACTUATORS

Valves can be supplied with any type of electric, hydraulic, or pneumatic actuator. Standard manual handwheels on valves 12" and smaller with 14" and larger bevel gear operated.

YOKE

Fully fabricated yoke is seismically qualified while offering easy maintenance and actuator mounting.

GLAND

Two piece, self-aligning gland eliminates cocking.

INTEGRAL BACKSEAT

Hard faced for maximum life.

WEDGE

One-piece, flexible wedge is fully guided, resists sticking or binding due to thermal expansion, has hardfaced seating surfaces for long life. Parallel seat or solid wedge also available.

FULLY GUIDED WEDGES/DISCS

Ensure positive shut-off in both horizontal & vertical orientation, reduction of currently known field failures

*Pacific Valve® offers Graphite/SS Capsulated Pressure Seal Bonnet Gaskets as a standard, Mild Steel Silver Plated Pressure Seal Bonnet Gaskets are available on request.

Flexible Wedge

The flex wedge is a one piece, fully guided wedge with a central hub to allow the seating faces to move relative to each other thus compensating for distortion of the body seats due to thermal expansion or piping loads. Seat ring and wedge seating surfaces are set on a 5 degree angle from vertical to minimize sliding contact of the wedge and seat ring during opening and closing. Wedging actions help affect a tight seal in low differential pressure services. Flexible wedge construction resists wedge sticking or binding in services where the valve may be closed when hot and opened when cold. Seating surfaces are hard faced to provide high cycle capability in very high differential pressure services.



Overview Y-Globe Non-Return Stop Check Valve

***ACTUATION**

Can be supplied with a hammerblow handwheel, manual gear set, electric motor operator, pneumatic, or hydraulic cylinder operator

STEM

Stainless steel stem is precision ground for minimal packing friction during operation.

STEM GUIDE

Acts as anti-rotating device for the stem.

YOKE

Designed to withstand seismic activities, the fully fabricated yoke features hassle-free assembly/ disassembly of topworks and simple actuator mounting.

INTEGRAL BACKSEAT

Hard faced for maximum life.

BODY

Streamlined flow path demonstrating high Cv factors which minimize pressure drop across a given system.

LARGE BW ENDS

To match two different outside diameters

BALANCED PLUG/DISC

With internal pressure self-relieving device (no external equalizing by-pass)

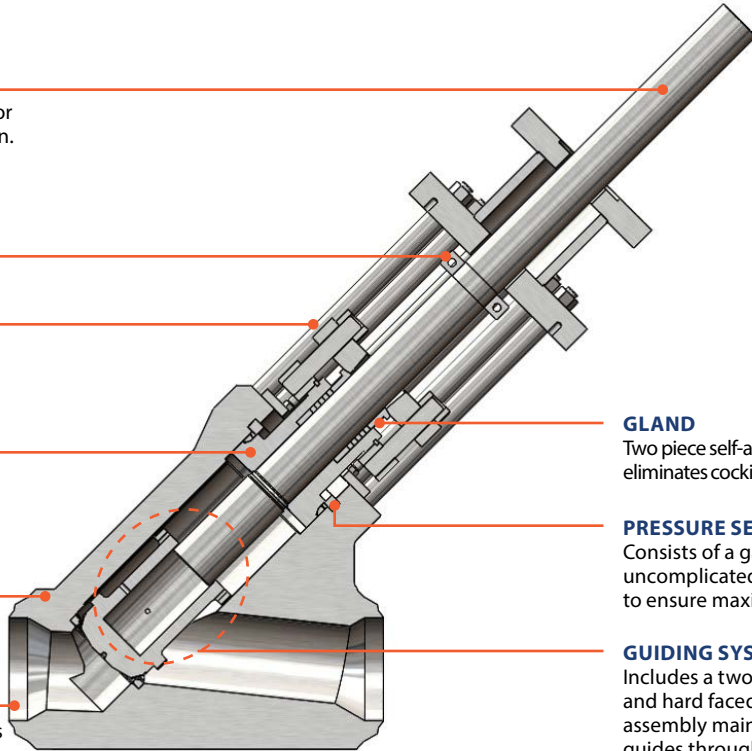

GLAND

Two piece self-aligning gland and gland flange eliminates cocking if packing adjustment is required.

PRESSURE SEAL DESIGN

Consists of a gasket, thrust ring and uncomplicated segmented retaining rings to ensure maximum bonnet seal*.*

GUIDING SYSTEM

Includes a two-piece disc assembly and hard faced body guides. The disc assembly maintains contact with the guides through the full valve stroke.

SEATING SURFACE

The disc and body seating surfaces are hard faced for extended service.

*Pacific Valve® offers Graphite/SS Capsulated Pressure Seal Bonnet Gaskets as a standard, Mild Steel Silver Plated Pressure Seal Bonnet Gaskets are available on request.



Overview Y-Globe Non-Return Stop-Check Valves

Y-Globe Non-Return Stop-Check Valves*

1. Globe valves are normally installed with flow and pressure under the disc. Always consult with the factory before installing valves with flow in the other direction. Under certain service conditions or when valves are equipped with cylinders or electric motor actuators, there may be a cost advantage in designing and installing the valves with flow over the disc. If actuators are sized for these conditions, care must be taken to assure valves are installed correctly.
2. Globe valves are suitable for most throttling applications; however, they should not be used for throttling at less than 10-20% open. This can cause excessive vibration, noise, and damage to disc and seats. Use of smaller valves with lower flow capacity may permit the valve to be open a greater percentage, thus avoiding damage. Continuous severe throttling applications may require a control valve.
3. Non-return (Stop-Check) valves provide the same function as a globe valve with the addition of providing piston-lift-check valve protection in the event of backflow. The valve stem is not connected to the disc, and when the stem is in the open position then the disc is free to respond to the flow.

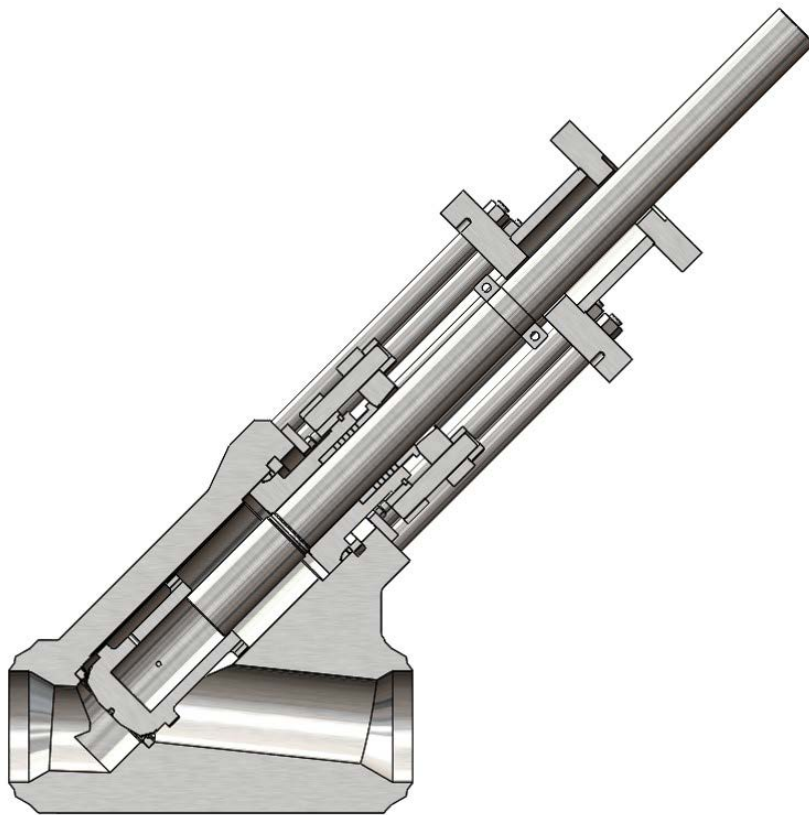

**Y-Pattern Globe Non-Return
(Stop-Check) Valve**

*For maximum reliability, it is recommended that Pacific Valves® Y-Globes Stop Check Valves be installed with flow axis horizontal and with bonnet above the valve in a vertical plane. Please consult factory for further details.

Overview Swing Check Valves

Check Valves

Highly Efficient

The self-aligning disc-hinge assembly and tapered seat ring allow sealing in no-flow conditions and/or in the case of flow reversal. The advantage of this design is flow is only permitted in one direction to protect major plant equipment, as well as minimizing backflow during seating of the disc.

Tight Shutoff

Spherical profile of the disc mounting arm allows for the disc to pivot about the hinge bore so that the disc is consistently aligned with the seat to provide exceptionally tight shutoff, and ensures the disc is always seated in no-flow conditions.

General Design Features

Long Life

The positive internal disc stop is an integral part of the body casting, providing a robust stopping point of the disc to prevent fluttering. Hardfaced seating surfaces prolong the life of the disc by reducing wear during normal operation where the disc can experience higher impacts due to the pendulum effect.

Internal Disc Hanger

Having the disc internally hinge eliminates body wall penetrations. The unique Pacific swing check valve not only eliminates potential leakage through external hinge pins, but the disc-hinge assembly is designed for ease of maintenance, by having only two bolts in the disc bracket that allow full removal of the disc-hinge assembly.

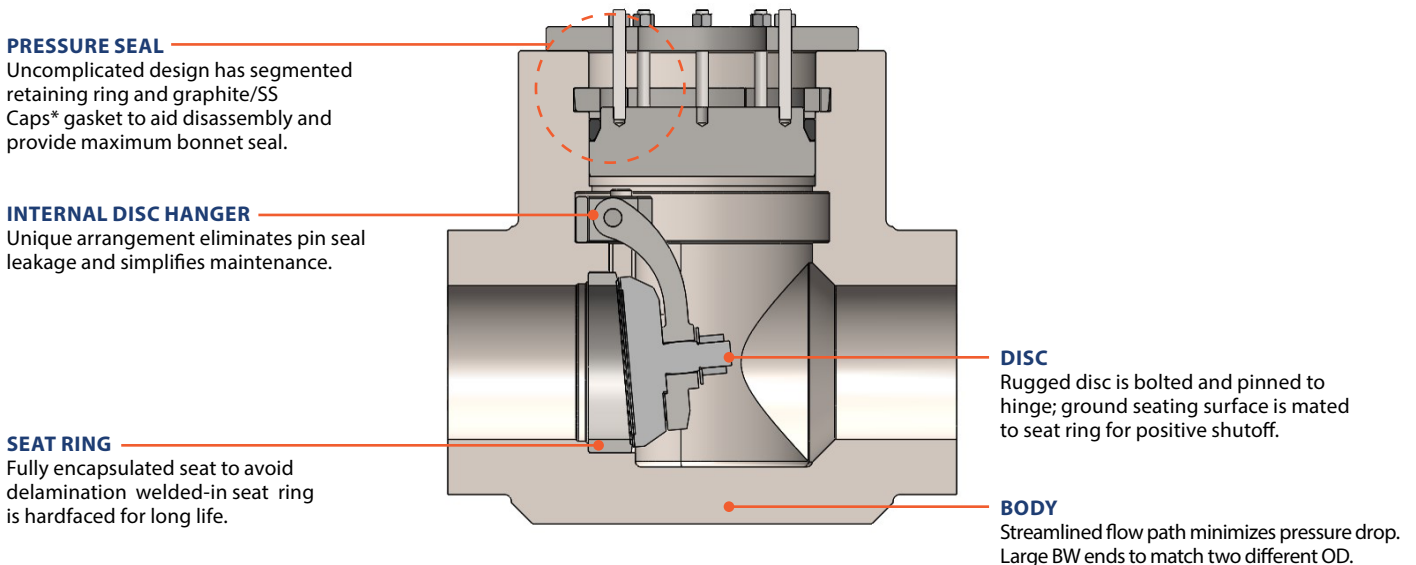

Swing Check Valve

PACIFIC VALVES® CODES AND STANDARDS:

Years of research and development, together with practical experience in reconditioning all types of valves, have gone into the design and manufacture of Pacific Valves®. High quality material and workmanship, combined with the modern manufacturing methods used in producing these valves, is your assurance of a dependable, uniform product. Pacific Valves® are designed in accordance with applicable requirements of the latest edition of the following standards.

API – American Petroleum Institute

MSS – Manufacturers' Standardization Society of the Valve and Fittings Industry

ASME – American Society of Mechanical Engineers



Crane ChemPharma & Energy
 Pacific Valves® Manufacturing Plant
 4444 Cooper Road
 Cincinnati, OH 45242
 Tel.: +1 513-745-6000
 Fax: +1 513-745-6086
 www.cranecpe.com



Crane ChemPharma & Energy
 Pacific Valves® Manufacturing Plant
 Ruiz de Alarcón 313, Complejo
 Industrial Chihuahua, 31000
 Chihuahua, Chih., Mexico
 Tel.: +52 614-442-9860

Crane ChemPharma & Energy
 Global Headquarters
 4526 Research Forest Drive, Suite 400
 The Woodlands, TX 77381
 Tel.: +1 936-271-6500
 Fax: +1 936-271-6510

brands you trust.



Crane Co., and its subsidiaries cannot accept responsibility for possible errors in catalogues, brochures, other printed materials, and website information. Crane Co. reserves the right to alter its products without notice, including products already on order provided that such alteration can be made without changes being necessary in specifications already agreed. All trademarks in this material are property of the Crane Co. or its subsidiaries. The Crane and Crane brands logotype, in alphabetical order, (ALOYCO®, CENTER LINE®, COMPAC-NOZ®, CRANE®, DEPA®, DUO-CHEK®, ELRO®, FLOWSEAL®, JENKINS®, KROMBACH®, NOZ-CHEK®, PACIFIC VALVES®, RESISTOFLEX®, REVO®, SAUNDERS®, STOCKHAM®, TRIANGLE®, UNI-CHEK®, WTA®, and XOMOX®) are registered trademarks of Crane Co. All rights reserved.