

NOZ-CHEK[®]

Brands you trust.

RELIABLE BACK-FLOW PREVENTION AND
ENGINEERED PERFORMANCE FOR THE MOST
CRITICAL APPLICATIONS



NOZ-CHEK[®]
High Performance Nozzle-Type
Non-Slam Axial Check Valve

CRANE[®]

v in www.cranecpe.com

NOZ-CHEK® Non-Slam Check Valve

STANDARD SCOPE OF SUPPLY

- Sizes 1"– 84"
- ASME B16.34 & API 6D, pressure classes 150 – 4500
- API 6A pressure ratings 2000 – 15,000
- Flanged, butt-weld ends, hubs ends and specials
- API 6D Short or Long face to face as well as Manufacturer's Standard
- Wide range of materials of construction available, consult factory for special application requirements

STANDARD FEATURES

1. Extensive research and development, coupled with robust design validation has resulted in industry leading features:

- **Few moving parts** - Disc is the only moving part, minimizing wear.
- **Axial movement of disc** - Disc and seating configuration give streamlined flow path, resulting in low pressure loss.
- **Short stroke of spring-assisted disc** - Inlet flow velocity moves disc axially with short stroke. In response to the reduction of the flow below the critical velocity, a compressed spring initiates valve closure and provides quick response
- **Spring options** - Choice of spring affects critical velocity and valve response. Selection is made on engineering evaluation of specific applications. In absence of this data, a standard spring will be provided.

CHARACTERISTICS

NOZ-CHEK® valves deliver an effective dynamic response under various flow deceleration conditions. The dynamic performance characteristics of NOZ-CHEK® valves are compared to swing check and dual plate spring-assisted check valves in Figure 1.

NOZ-CHEK®'s design features result in superior performance, fast response and low pressure loss in piping systems.

OPENING

When the valve begins to open an increase in kinetic pressure, generated by increased velocity in the reduced flow area, assists the disc to open and permits extra spring loading that facilitates fast closure.

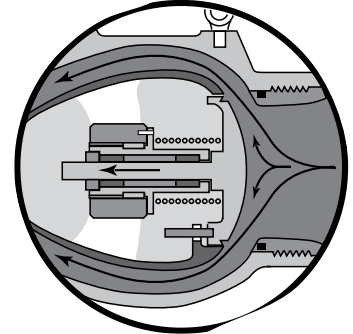

The spring force is exceeded in the fully open position.

The NOZ-CHEK® geometry permits full opening from relatively low flows to ensure that the disc is stabilized against its stop even if moderate flow oscillation occurs.

CLOSING

When the flow drops below the critical velocity, the disc will begin to close. Selecting the correct spring limits backflow and water hammer.

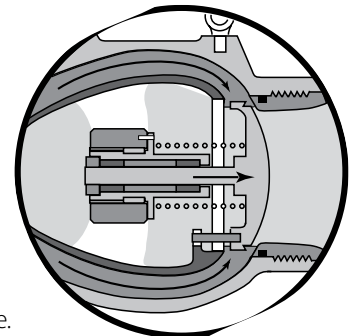

The spring load, low mass disc, and short displacement ensures a rapid self-dampening response.

For certain applications, the internal geometry can be modified to suit the service conditions.

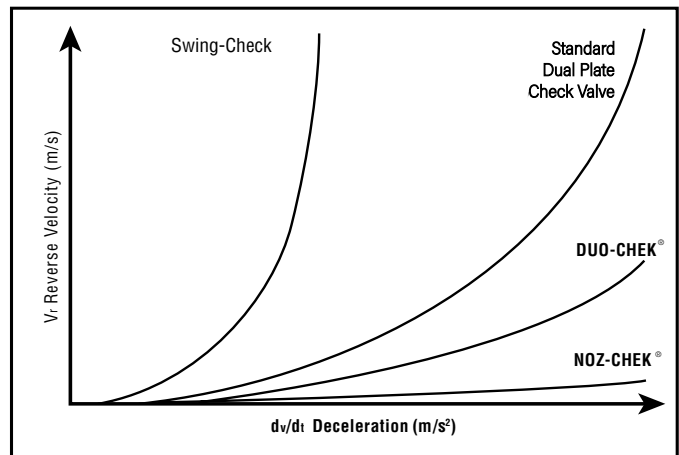

Figure 1

NOZ-CHEK® Capabilities, Features & Benefits

HIGH PERFORMANCE NON-SLAM CHECK VALVE

One of the most significant elements of piping system design is integrating the means to protect mechanical equipment and prevent damage caused by backflow. Backflow prevention is routinely achieved through the use of swing check valves or dual-plate check valves.

NOZ-CHEK® valves are specifically designed for fast-reversing systems where backflow is a constant concern. In such critical service applications, NOZ-CHEK® Non-Slam Check Valves offer the following benefits.

- **Minimizes the damaging effects of water hammer in fluid systems**
- **Removal of chatter associated with conventional valves in reciprocating compressor service**
- **Protects rotating equipment from damage due to flow reversal**
- **Minimizes pressure loss in piping systems**
- **Provides quick dynamic response reducing reverse velocity**

LOW CRYOGENIC LEAK RATE PER BS 6364 INDUSTRY STANDARD

NOZ-CHEK® valves meet the standard requirements of ASME B16.34, API 6D and API 598. When specified for Cryogenic service, the NOZ-CHEK® cryogenic valve can meet the rigorous requirements of BS 6364 (300 cc/min/in at -196°C/ -320°F), Shell 77/200, MSS SP-134, ISO 28921-1.

ZERO FUGITIVE EMISSIONS

NOZ-CHEK® products feature a single piece solid body (no penetrations or external leak paths), reflecting our commitment to environmental responsibility and critically ensuring zero fugitive emissions.

IN-HOUSE CRYOGENIC TESTING

The low temperature and Cryogenic High-Pressure gas testing is carried out on-site in our state of the art testing facilities. Test capability 1" to 72" and test pressures of 22,500 PSI.

INNOVATION OF PROVEN TECHNOLOGY

Dedication to solving our Customers' challenges, longstanding commitment to safety and quality continue to drive our product innovation.

Industry Standards, Specifications and Directives*	
API 598	Valve Pressure Testing and Inspection
ASME B16.34	Pressure/Temperature Ratings
API 6D	Pipeline Valves
API 6A	Specification for Wellhead and Tree Equipment
2014/68/EU	Pressure Equipment Directive
ISO 28921 – 1	International Standards Organisation Cryogenic testing
BS 6364	British Standard Cryogenic testing
MSS SP-134	Manufacturing Standards Society Cryogenic testing
MSS SP-160	Valves for Hydrogen Fluoride(HF) and Alkylation Service
MSS SP - 126	In-Line, Spring-Assisted, Center-Guided Check Valves

*Consult factory for other specification requirements.



Oil and Gas Production

- Centrifugal Compressor Discharge
- Fire Water Lines
- Oil/Steam Separation
- Steam and CO₂ Injection
- Gas/Oil Gathering Systems
- Flowlines
- Wellheads
- Regasification
- Liquidfaction

Power Generation

- Steam
- Condensate
- Boiler Feed Pumps
- Cooling Towers
- Service Water Recirculators
- River Water Intake
- Nuclear Energy

Petroleum Refining

- Hydrogen
- Cracking
- Steam
- Crude Oil
- Gasoline
- Visbreakers
- Naphtha
- Sulfur
- HF Alkylation service

Petrochemicals

- Ethylene
- Propylene
- Steam
- Reboilers
- Gases
- EO/EG

Chemicals

- Chlorine
- Phosgene
- Aromatics
- Polymers
- Acids
- Air Separation
- Caustics

Water and Wastewater

- Distribution Lines
- Pumping Stations
- Sewage Plant Blower Discharge
- Chemical Treatment
- Fire Protection Systems
- HVAC Systems
- Desalination

Steel/Primary Metals

- Quench Lines
- De-Scaling
- Continuous Casters
- Steam
- Condensate
- Strippers
- Electro-Galvanizing

Pulp and Paper

- Bleaching Lines
- Black Liquor
- Green Liquor
- White Water
- Steam
- Chemical Recovery

Marine

- FPSO
- Oil Tankers
- Tanker Loading Terminals
- Offshore Platforms
- Sub-Sea Manifolds
- Terminal Transfer Lines
- Barge Unloading Lines
- Shipboard Services

Renewables

- Solar Power
- Wave Power
- Green Hydrogen
- Carbon Capture

Gas Transmission

- Compressor Suction/Discharge/Bypass

Typical Cryogenic Applications

- LNG
- Liquefaction Compression Train
- Mixed Refrigerant
- Ethylene Production
- Ethylene Refrigeration
- Air Separation Units
- General Cryogenic compressor protection



Flanged End Dimensional Data - TC / TCS

1 DISC

Standard disc is high strength with minimized weight to provide fast dynamic response. Design minimizes bearing loads, thus lengthens life of bearings and shaft. Offered in a variety of trim materials, with metal or resilient seating.

2 FLOW OUTLET ZONE

Diffuser and body geometry controls the flow path to minimize pressure loss.

3 INTEGRAL SEAT

Provides seating surface for disc and enables bubble-tight seal with resilient materials.

4 FLOW INLET ZONE

Venturi effect maximizes flow impact on disc. Provides streamlined flow when valve is fully open to minimize pressure loss.

5 SPRING

Each valve is designed with a bespoke spring to best meet the specific customer service conditions.

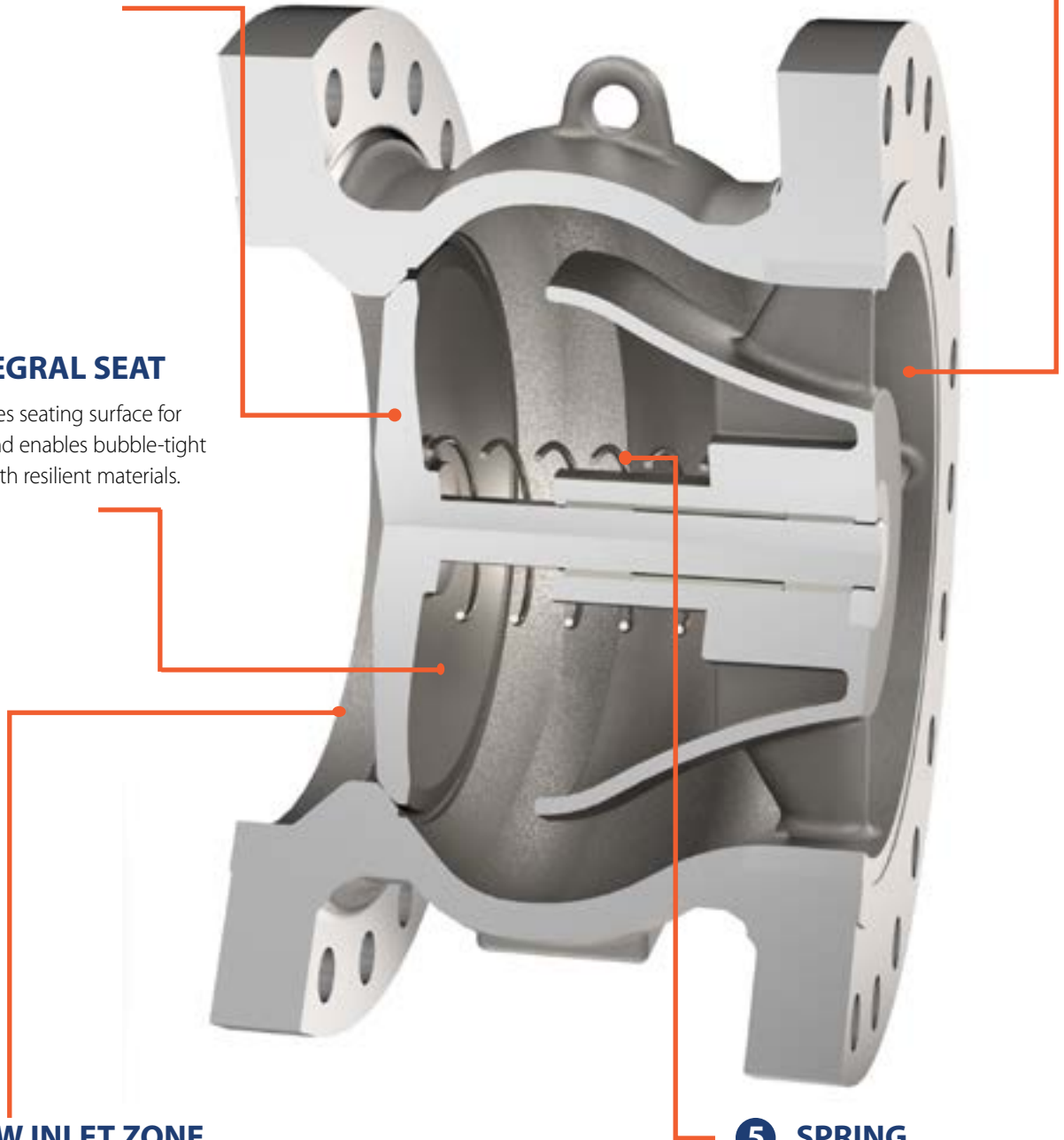

Flanged End Dimensional Data - TC / TCD/ TCV

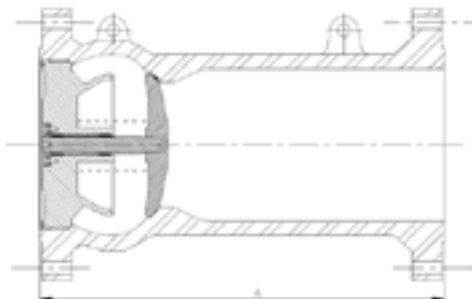

Style **TC**
API 6D Long Pattern

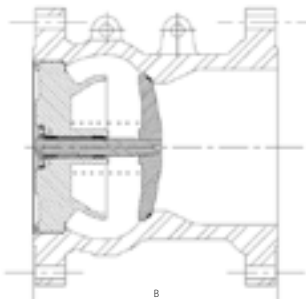

Style **TCD**
API 6D Short Pattern

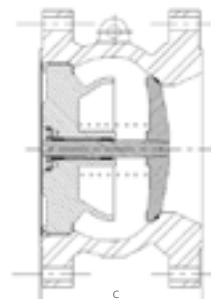

Style **TCV**
Manufacturer's Standard
Pattern

Class 150 RF						
Nominal Size	API 6D Long Pattern	API 6D Short Pattern	Mfr Standard Pattern	Weight		
				A in (mm)	B in (mm)	C in (mm)
2	8.00 (204)	-	-	17.6 (8)	-	-
3	9.50 (241)	-	-	37.4 (17)	-	-
4	11.50 (292)	-	-	63.8 (29)	-	-
6	14.00 (356)	8.27 (210)	-	99 (45)	77 (35)	-
8	19.50 (495)	11.02 (280)	-	176 (80)	136.4 (62)	-
10	24.50 (622)	13.78 (350)	-	357.0 (162)	287.0 (130)	-
12	27.50 (699)	13.78 (350)	-	560.0 (254)	437.0 (198)	-
14	31.00 (787)	15.94 (405)	14.00 (356)	637.0 (289)	465.0 (211)	432.0 (196)
16	34.00 (864)	17.91 (455)	15.00 (381)	807.0 (367)	584.0 (265)	542.0 (246)
18	38.50 (978)	20.47 (520)	16.75 (425)	1063.0 (482)	778.0 (353)	741.0 (336)
20	38.50 (978)	22.44 (570)	17.50 (445)	1294.0 (587)	1003.0 (455)	893.0 (405)
24	51.00 (1295)	26.97 (685)	19.00 (483)	2018.0 (915)	1451.0 (658)	1272.0 (577)
30	60.00 (1524)	33.66 (855)	27.00 (686)	4128.0 (1872)	3142.0 (1425)	2792.0 (1266)
36	77.00 (1956)	40.55 (1030)	30.50 (775)	7036.0 (3191)	5122.0 (2323)	4379.0 (1986)

Class 300 RF						
Nominal Size	API 6D Long Pattern	API 6D Short Pattern	Mfr Standard Pattern	Weight		
				A in (mm)	B in (mm)	C in (mm)
2	10.50 (267)	-	-	24.6 (11.2)	-	-
3	12.50 (318)	-	-	48.4 (22)	-	-
4	14.00 (356)	-	-	85.8 (39)	-	-
6	17.50 (445)	8.27 (210)	-	143.6 (65.3)	112.9 (51.31)	-
8	21.00 (533)	11.02 (280)	-	283.8 (129)	212 (96.5)	-
10	24.50 (622)	13.78 (350)	-	426.0 (193)	355.0 (161)	-
12	28.00 (711)	13.78 (350)	-	675.0 (306)	551.0 (250)	-
14	33.00 (838)	15.94 (405)	14.00 (356)	811.0 (368)	615.0 (279)	591.0 (268)
16	34.00 (864)	17.91 (455)	15.00 (381)	1010.0 (458)	785.0 (356)	739.0 (335)
18	38.50 (978)	20.47 (520)	16.75 (425)	1327.0 (602)	1045.0 (474)	1036.0 (470)
20	40.00 (1016)	22.44 (570)	17.50 (445)	1647.0 (747)	1325.0 (601)	1235.0 (560)
24	53.00 (1346)	26.97 (685)	19.00 (483)	2701.0 (1225)	2018.0 (915)	1852.0 (840)
30	62.75 (1524)	33.66 (855)	27.00 (686)	4981.0 (2259)	3892.0 (1765)	3636.0 (1649)
36	82.00 (2083)	40.55 (1030)	30.50 (775)	8161.0 (3701)	5982.0 (2713)	5479.0 (2485)

Flanged End Dimensional Data - TC / TCD/ TCV

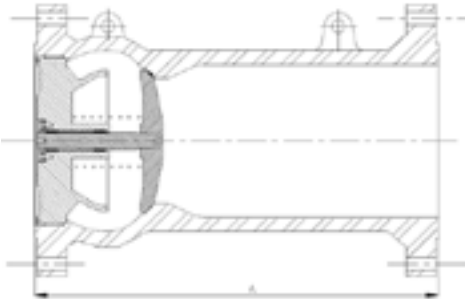

Style **TC**
API 6D Long Pattern

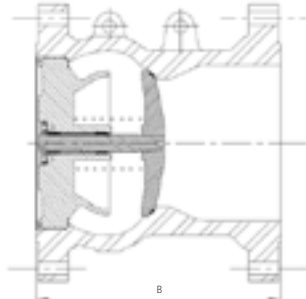

Style **TCD**
API 6D Short Pattern

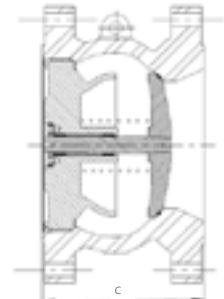

Style **TCV**
Manufacturer's Standard
Pattern

Class 600 RF						
Nominal Size	API 6D Long Pattern	API 6D Short Pattern	Mfr Standard Pattern	Weight		
				A in (mm)	B in (mm)	C in (mm)
2	11.50 (292)	-	-	27.0 (12.5)	-	-
3	14.00 (356)	-	-	54.3 (24.7)	-	-
4	17.00 (432)	-	-	112.6 (51.2)	-	-
6	22.00 (559)	8.27 (210)	-	229.9 (104.5)	169.4 (77)	-
8	26.00 (660)	11.02 (280)	-	393.8 (179)	284.0 (129)	-
10	31.00 (787)	13.78 (350)	-	792.0 (359)	622.0 (282)	-
12	33.00 (838)	14.76 (375)	-	1025.0 (465)	774.0 (351)	-
14	35.00 (889)	17.32 (440)	-	1301.0 (590)	893.0 (405)	-
16	39.00 (991)	19.69 (500)	-	2461.0 (1116)	1874.0 (850)	-
18	43.00 (1092)	22.24 (565)	20.00 (508)	2604.0 (1181)	2115.0 (959)	2062.0 (935)
20	47.00 (1194)	24.61 (625)	20.00 (508)	2767.0 (1255)	2201.0 (998)	2084.0 (945)
24	55.00 (1397)	29.33 (745)	22.50 (572)	4298.0 (1949)	3274.0 (1485)	3001.0 (1361)
30	65.00 (1651)	36.61 (930)	31.00 (787)	7358.0 (3337)	5654.0 (2564)	5316.0 (2411)
36	82.00 (2083)	44.09 (1120)	32.50 (826)	11634.0 (5276)	8423.0 (3820)	7442.0 (3375)

Class 900 RTJ						
Nominal Size	API 6D Long Pattern	API 6D Short Pattern	Mfr Standard Pattern	Weight		
				A in (mm)	B in (mm)	C in (mm)
2	14.63 (371)	-	-	69.1 (31.4)	-	-
3	15.13 (384)	-	-	102.7 (46.7)	-	-
4	18.13 (460)	-	-	169.0 (76.8)	-	-
6	24.13 (613)	9.06 (230)	-	328 (149)	239 (108.8)	-
8	19.13 (740)	11.02 (280)	-	579 (263)	425 (193)	-
10	33.13 (842)	13.78 (350)	-	851 (386)	580 (263)	-
12	38.13 (969)	16.93 (430)	-	1782 (808)	1226 (556)	-
14	40.88 (1038)	15.75 (400)	-	2082 (944)	1458 (661)	-
16	44.88 (1140)	18.50 (470)	-	2624 (1190)	1837 (833)	-
18	48.50 (1232)	20.87 (530)	-	3308 (1500)	2315 (1050)	-
20	52.20 (1332)	23.43 (595)	-	3638 (1650)	2547 (1155)	-
24	61.75 (1568)	26.18 (665)	-	8114 (3680)	6372 (2890)	-

Flanged End Dimensional Data - TC / TCD/ TCV

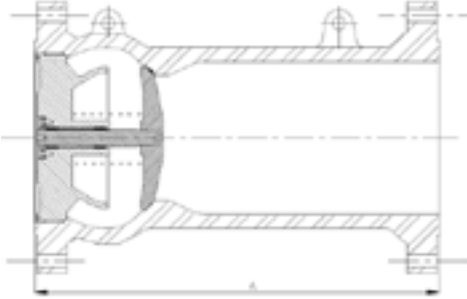

Style **TC**
API 6D Long Pattern

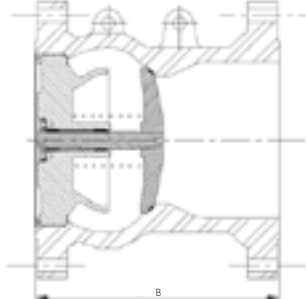

Style **TCD**
API 6D Short Pattern

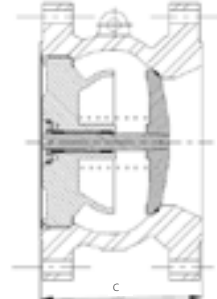

Style **TCV**
Manufacturer's Standard
Pattern

Class 1500 RTJ									
Nominal Size	API 6D Long Pattern	API 6D Short Pattern	Mfr Standard Pattern	Weight					
				A in (mm)	B in (mm)	C in (mm)	A lbs. (kg)	B lbs. (kg)	C lbs. (kg)
2	14.63 (371)	-	-	69.1 (31.4)	-	-	-	-	-
3	18.63 (473)	-	-	137.5 (62.5)	-	-	-	-	-
4	21.63 (549)	-	-	216.5 (98.4)	-	-	-	-	-
6	28.00 (711)	12.20 (310)	-	474.3 (215.6)	360.5 (163.88)	-	-	-	-
8	33.13 (841)	13.78 (350)	-	853.6 (388)	391.6 (278)	-	-	-	-
10	39.38 (1000)	15.75 (400)	-	1874 (850)	725.0 (329)	-	-	-	-
12	45.13 (1146)	17.72 (450)	-	2624 (1190)	1874 (850)	-	-	-	-
14	50.25 (1276)	19.29 (490)	-	3859 (1750)	2701 (1225)	-	-	-	-
16	55.38 (1407)	20.87 (530)	-	4355 (2450)	3872 (1715)	-	-	-	-
18	61.38 (1559)	22.83 (580)	-	6174 (2800)	4322 (1960)	-	-	-	-
20	66.38 (1686)	25.79 (655)	-	8732 (3960)	5918 (2684)	-	-	-	-
24	77.63 (1972)	29.53 (750)	-	13517 (6130)	10209 (4630)	-	-	-	-

Class 2500 RTJ									
Nominal Size	API 6D Long Pattern	API 6D Short Pattern	Mfr Standard Pattern	Weight					
				A in (mm)	B in (mm)	C in (mm)	A lbs. (kg)	B lbs. (kg)	C lbs. (kg)
2	17.88 (454)	-	-	102.1 (46.4)	-	-	-	-	-
3	23.00 (584)	-	-	239.8 (109)	-	-	-	-	-
4	26.88 (683)	-	-	366.7 (166.7)	-	-	-	-	-
6	36.50 (927)	16.93 (430)	-	917.4 (417)	737 (335)	-	-	-	-
8	40.88 (1038)	18.11 (460)	-	1502.6 (683)	1128.6 (513)	-	-	-	-
10	50.88 (1292)	22.83 (580)	-	1837.0 (833)	1268.0 (575)	-	-	-	-
12	56.88 (1445)	22.83 (580)	-	4571 (2073)	2589 (1174)	-	-	-	-

NOZ-CHEK® Design Features NC / NCS / NCV

1 DISC

Standard disc is high strength with minimized weight to provide fast dynamic response. Design minimizes bearing loads, thus lengthens life of bearings and shaft. Offered in a variety of trim materials, with metal or resilient seating.

2 FLOW OUTLET ZONE

Geometry controls the flow path to minimize pressure loss.

3 SEAT

Provides seating surface for disc and enables bubble-tight seal with resilient materials.

4 FLOW INLET ZONE

Venturi effect maximizes flow impact on disc. Provides streamlined flow when valve is fully open to minimize pressure loss.

5 SPRING

Each valve is designed with a bespoke spring to best meet the specific customer service conditions.

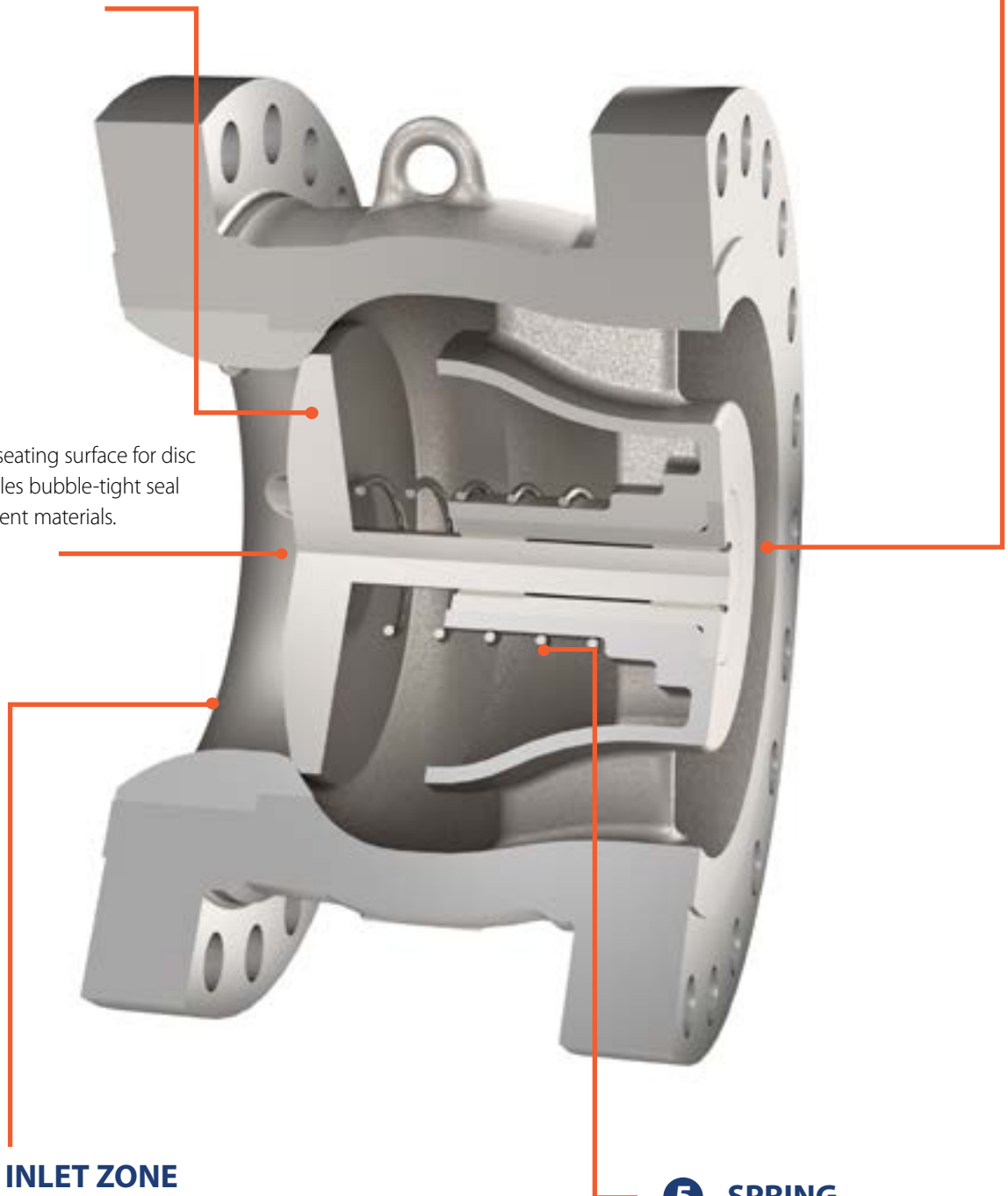

Flanged End - Dimensional Data NCD / NCV

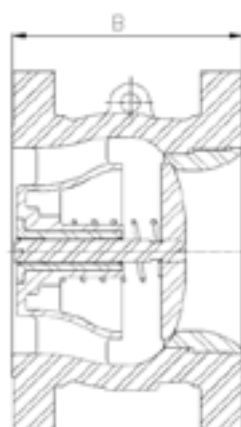
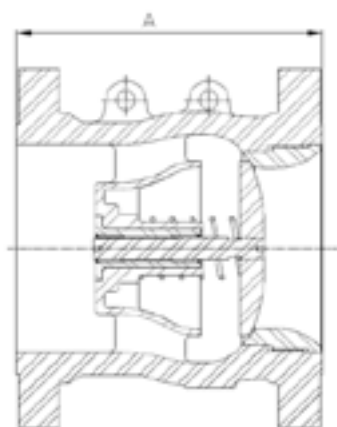

Style **NCD**

Style NCS API 6D Short
Pattern above 36"

Style **NCV**

Manufacturer's Standard
Pattern above 36"

Class 150 RF				
Nominal Size	API 6D Short Pattern	Mftr Standard Pattern	Weight	
	A in (mm)	B in (mm)	A lbs. (kg)	B lbs. (kg)
36	40.55 (1030)	32.00 (813)	4,138 (1880)	3,877 (1762)
42	47.05 (1195)	35.00 (889)	5,529 (2513)	5,060 (2300)
48	53.74 (1365)	38.00 (965)	8,518 (3871)	7,722 (3510)
54	60.24 (1530)	41.00 (1041)	12,260 (5573)	11,286 (5130)
60	67.32 (1710)	45.00 (1143)	13,867 (6303)	13,072 (5942)

Class 300 RF				
Nominal Size	API 6D Short Pattern	Mftr Standard Pattern	Weight	
	A in (mm)	B in (mm)	A lbs. (kg)	B lbs. (kg)
36	40.55 (1030)	32.00 (813)	5,710 (2595)	5,270 (2395)
42	47.05 (1195)	35.00 (889)	9,513 (4323)	8,712 (3960)
48	53.74 (1365)	38.00 (965)	13,621 (6190)	12,283 (5583)
54	60.24 (1530)	41.00 (1041)	14,408 (6550)	12,320 (5600)
60	67.32 (1710)	45.00 (1143)	22,492 (10224)	20,064 (9120)

Class 600 RF				
Nominal Size	API 6D Short Pattern	Mftr Standard Pattern	Weight	
	A in (mm)	B in (mm)	A lbs. (kg)	B lbs. (kg)
36	44.09 (1120)	34.00 (864)	11,213 (5096)	10,252 (4660)
42	51.18 (1300)	32.13 (816)	11,490 (5223)	9,405 (4275)
48	58.46 (1485)	32.13 (816)	15,946 (7248)	12,767 (5803)
54	65.75 (1670)	35.13 (892)	22,357 (10163)	18,656 (8480)
60	73.03 (1855)	46.50 (1181)	32,253 (14660)	26,506 (12048)

Class 900 RF				
Nominal Size	API 6D Short Pattern	Mftr Standard Pattern	Weight	
	A in (mm)	B in (mm)	A lbs. (kg)	B lbs. (kg)
36	41.34 (1050)	36.00 (915)	13,031 (5923)	12,320 (5600)
42	49.21 (1250)	40.00 (1016)	20,297 (7991)	16,115 (7325)
48	57.09 (1450)	44.00 (1,118)	26,000 (11817)	23,305 (10593)

*Note -For other Nominal sizes or special face to face lengths please consult factory

NOZ-CHEK® Quality Management and Testing

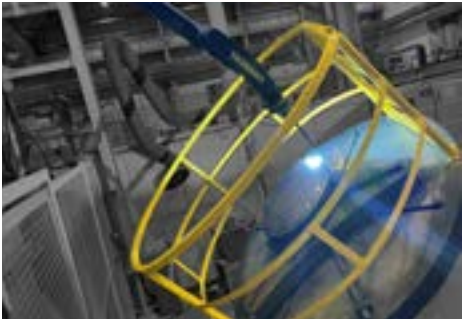

TOTAL QUALITY MANAGEMENT

CRANE is guided by a commitment to total quality management with a focus in customer satisfaction. Cranes Quality Management System is approved to ISO 9001, and certified to Module H of the Pressure Equipment Directive 2014/68/EU

DESIGN

Computer-aided design (CAD) systems at CRANE are helpful in developing sound designs. Finite element analysis is utilized to conduct simulated stress analyses for various valve structures to prove design integrity. Flow modeling is applied to optimize pressure loss characteristics. Computer-aided spring designs and disc weight have improved the NOZ-CHEK® valve response times.

MANUFACTURING CAPABILITIES

NOZ-CHEK® valves can be furnished in sizes from 1- 84" (20 -2100 mm), and in pressure classes from ASME Class 150 - 4500 and API ratings from 2000 -15,000 psi CWP.

A variety of body and trim material is offered, including carbon steel, ductile iron, alloy steels, stainless steel and duplex steel. Coatings may be provided for added corrosion or wear resistance. Hard-facing and weld overlays may also be supplied. Seats may be metal-to-metal or bubble-tight resilient.

TESTING

Inspection and testing are applied throughout the manufacturing process.

- Special nondestructive testing is often specified, which may include radiography, magnetic particle and liquid penetrant.
- Cryogenic and fire tests can be conducted to satisfy customer requirements. The test enclosure is able to test valves up to 72" and to pressures of 22,500 PSI, ensuring extensive coverage of the Crane Engineered Check product range.
- Each valve is hydrostatically tested to API Standard 598. These tests apply to the body shell and seat, with test duration and leakage rates pertaining to customer requirements. Other test standards are also specified in some cases.



Additional Engineered Check Products

Certificates

- ISO 9001
- ISO 14000
- ISO 45000
- API 6D
- PED
- API 6FD/6FA
- CRN
- TR032
- TSG
- API 6FA
- ISO 14644-1 Class 6



STYLE H

Retainerless Wafer/ Double Flange/ lug Valves

- Sizes 2" – 84"
- ASME Classes 150 – 2500
- Ring Type Joint, Plain or Serrated Ends
- Carbon Steel, Stainless Steel and Exotic materials



STYLE P

Cryogenic Duo-Chek

Sizes 2" - 36"

- ASME Classes 150-600
- Designed for cryogenic applications to -196°C



UNI-CHEK®

Single-Disc Check Valves

- Sizes 2" – 36"
- ASME Classes 125 – 300
- Flanged, Plain, or Serrated Ends
- Cast Iron, Carbon Steel, and Stainless Steel
- Variety of external shaft options available



STYLE X

Extended Body Wafer

Sizes 10" – 84"

- ASME Classes 150 – 2500
- Designed for extremely fast opening applications



COMPAC-NOZ®

Compact Body Nozzle Check Valves

- Sizes 2" – 48"
- ASME Classes 150 – 2500
- Double Flanged / Lug / Wafer
- Carbon Steel, Stainless Steel, and exotic materials
- ASME, EN, JIS Standards

NOZ-CHEK® Ordering Information

24"	TC	30	S	M	F	9
Valve Size	Style	Pressure Class	Body	Seal	End Connection	Modification Number

Description: ; 24" Non-Integral Diffuser, Standard API 6D Long Pattern, ASME Class 300, Carbon Steel Body, Buna-N Seal, Serrated Raised Face. (Modification number to be assigned at order stage).

VALVE SIZE

Nominal valve sizes are expressed in inches, for ASME and API flange standards or millimeters for EN flange standards. (Size preceded by "M" for EN)

SEAL Operating temperature for general guidance only

Code Letter	Seal Material	Maximum Recommended Operating Temperatures	
		°C	°F
M	Buna-N	-25 to 110	-13 to 130
V	FKM-B	-15 to 200	5 to 392
P	Metal	-257 to 537	-450 to 1000
Z	EPDM	-25 to 120	-49 to 250

Metal seats may be furnished as integral or special overlay materials are available.

STYLE

Ordering Letter	Body Style	Size Range
NCD	Integral Body, Standard API 6D Short Pattern	38" through 60" (950mm through 1500mm)
NCV	Integral Body, Short Body Manufacturer's Pattern	38" through 84" (950mm through 2100mm)
TC	Non-Integral Diffuser, Standard API 6D Long Pattern	1" through 36" (20mm through 900mm)
TCD	Non-Integral Diffuser, Standard API 6D Short Pattern	2" through 36" (50mm through 900mm)
TCV	Non-Integral Diffuser, Short Body Manufacturer's Pattern	10" through 36" (250mm through 900mm)

FLANGE SERIES (ASME B16.47 Series "A" or "B" to be specified over 24") guidance only

ASME	
Ordering No.	Pressure Class
15	150
30	300
60	600
90	900
150	1500
250	2500
450	4500

API	
Ordering No.	Rating
21	2000
31	3000
51	5000
101	10,000
151	15,000

Metric - EN	
Ordering No.	Rating
6	PN6
10	PN10
16	PN16
25	PN25
40	PN40
63	PN63
100	PN100
160	PN160
250	PN250
320	PN320
400	PN400

NOZ-CHEK® Ordering Information

24"

Valve Size

NC

Style

30

Pressure Class

S

Body & Trim

M

Seal

F

End Connection

9

Modification Number

Description: 24" Style NC, ASME Class 300, Carbon Steel Body, Buna-N Seal, Raised Face Flanges
(Modification number to be assigned at order stage.)

STANDARD BODY & DISC MATERIALS

Code	Body	Disc
S	ASTM A 216 GR WCB carbon steel	alloy steel
C	ASTM A 351 GR CF8M 316 stainless steel	stainless steel
DD	BS EN 1563 GR EN-GJS-450-10 ductile iron	stainless steel
GC	ASTM A 352 GR LCC low temp. carbon steel	alloy steel
DZ	ASTM A995 GR 4A duplex stainless steel	Duplex SS

Other high grade and alloy materials are available as cast and forged grades.

SPRING MATERIAL

Spring Material	Maximum Recommended Operating Temperatures	
	°C	°F
316 Stainless Steel	300	572
Inconel® X-750	550	1022

Inconel® is a registered trademark of Special Metals Corporation.
For temperatures up to 700°F (370°C), Inconel X-750 spring temper will be furnished as standard. For higher temperatures the appropriate heat treat will be carried out.
Other alloy spring materials are available to meet specific service requirements.

END CONNECTIONS

Ordering Letter	Connections
F	Flanged, Raised Face, Serrated
X	Special Facing
G	Hub End
P	Flanged, Raised Face, Non-serrated (125 µin Max.)
R	Flange, Flat Face, Ring Joint
W	Butt Weld End

MODIFICATIONS

A modification number is assigned when non-standard features, material mixes or documentation are ordered.

CRANE®

CRANE CHEMPHARMA & ENERGY

4526 Research Forest Drive,
Suite 400
The Woodlands
Texas 77381, U.S.A.
Tel: +1 936 271 6500

Sydney, Australia Operations
146-154 Dunheved Circuit
St. Marys, NSW 2760 Australia
Tel: +61 2 9623 0234

Crane Process Flow
Technologies (India) Ltd
E7 / E8 -2 Old MIDC
Satara - 415 004 India
Tel: +91 2162 244417

Crane Middle East & Africa FZE
PO Box 17415
Jebel Ali Freezone
Dubai, UAE
Tel: +971 4 816 5800

Tanwei Industrial District
West of 2nd Industrial Area
34341 Dammam
Saudi Arabia
Tel: +966 13 895 7058

Crane Company, and its subsidiaries cannot accept responsibility for possible errors in catalogues, brochures, other printed materials, and website information. Crane Company reserves the right to alter its products without notice, including products already on order provided that such alteration can be made without changes being necessary in specifications already agreed. All trademarks in this material are the property of the Crane Company or its subsidiaries. The Crane and Crane brands logotype (ALOYCO®, BAUM®, CENTER LINE®, CRANE®, CRANE CRYOGENICS™, CRYOWORKS®, DEPA® & ELRO®, DOPAK®, DUO-CHEK®, FLOWSEAL®, GYROLOK®, GO REGULATOR®, HOKE®, JENKINS®, KROMBACH®, NOZ-CHEK®, PACIFIC®, RESISTOFLEX®, REVO®, SAUNDERS®, STOCKHAM®, TECHNIFAB®, TEXAS SAMPLING®, WESTLOCK®, WTA®, and XOMOX®) are registered trademarks of Crane Company. All rights reserved.

NOZ-CHEK[®]

Brands you trust.

RELIABLE BACK-FLOW PREVENTION AND
ENGINEERED PERFORMANCE FOR THE MOST
CRITICAL APPLICATIONS



NOZ-CHEK[®]
High Performance Nozzle-Type
Non-Slam Axial Check Valve

CRANE[®]

v in www.cranecpe.com

NOZ-CHEK® Non-Slam Check Valve

STANDARD SCOPE OF SUPPLY

- Sizes 1" – 84"
- ASME B16.34 & API 6D, pressure classes 150 – 4500
- API 6A pressure ratings 2000 – 15,000
- Flanged, butt-weld ends, hubs ends and specials
- API 6D Short or Long face to face as well as Manufacturer's Standard
- Wide range of materials of construction available, consult factory for special application requirements

STANDARD FEATURES

1. Extensive research and development, coupled with robust design validation has resulted in industry leading features:

- **Few moving parts** - Disc is the only moving part, minimizing wear.
- **Axial movement of disc** - Disc and seating configuration give streamlined flow path, resulting in low pressure loss.
- **Short stroke of spring-assisted disc** - Inlet flow velocity moves disc axially with short stroke. In response to the reduction of the flow below the critical velocity, a compressed spring initiates valve closure and provides quick response
- **Spring options** - Choice of spring affects critical velocity and valve response. Selection is made on engineering evaluation of specific applications. In absence of this data, a standard spring will be provided.

CHARACTERISTICS

NOZ-CHEK® valves deliver an effective dynamic response under various flow deceleration conditions. The dynamic performance characteristics of NOZ-CHEK® valves are compared to swing check and dual plate spring-assisted check valves in Figure 1.

NOZ-CHEK®'s design features result in superior performance, fast response and low pressure loss in piping systems.

OPENING

When the valve begins to open an increase in kinetic pressure, generated by increased velocity in the reduced flow area, assists the disc to open and permits extra spring loading that facilitates fast closure.

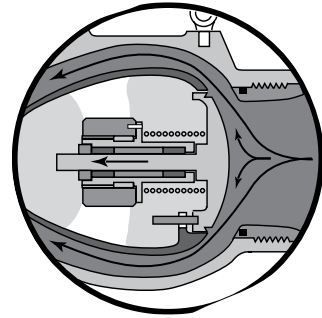

The spring force is exceeded in the fully open position.

The NOZ-CHEK® geometry permits full opening from relatively low flows to ensure that the disc is stabilized against its stop even if moderate flow oscillation occurs.

CLOSING

When the flow drops below the critical velocity, the disc will begin to close. Selecting the correct spring limits backflow and water hammer.

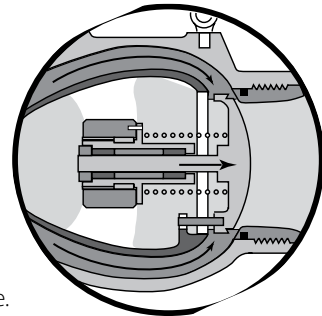

The spring load, low mass disc, and short displacement ensures a rapid self-dampening response.

For certain applications, the internal geometry can be modified to suit the service conditions.

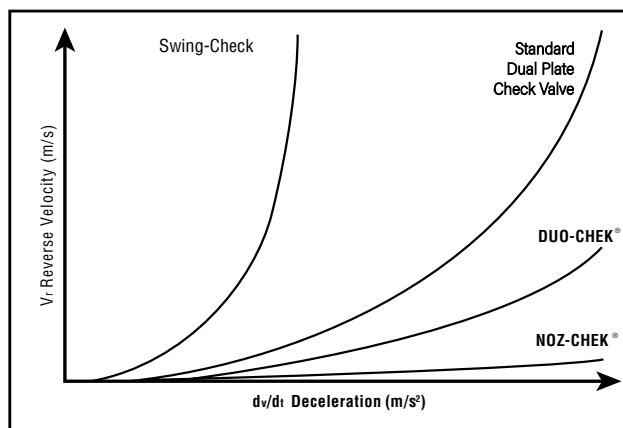

Figure 1

NOZ-CHEK® Capabilities, Features & Benefits

HIGH PERFORMANCE NON-SLAM CHECK VALVE

One of the most significant elements of piping system design is integrating the means to protect mechanical equipment and prevent damage caused by backflow. Backflow prevention is routinely achieved through the use of swing check valves or dual-plate check valves.

NOZ-CHEK® valves are specifically designed for fast-reversing systems where backflow is a constant concern. In such critical service applications, NOZ-CHEK® Non-Slam Check Valves offer the following benefits.

- **Minimizes the damaging effects of water hammer in fluid systems**
- **Removal of chatter associated with conventional valves in reciprocating compressor service**
- **Protects rotating equipment from damage due to flow reversal**
- **Minimizes pressure loss in piping systems**
- **Provides quick dynamic response reducing reverse velocity**

LOW CRYOGENIC LEAK RATE PER BS 6364 INDUSTRY STANDARD

NOZ-CHEK® valves meet the standard requirements of ASME B16.34, API 6D and API 598. When specified for Cryogenic service, the NOZ-CHEK® cryogenic valve can meet the rigorous requirements of BS 6364 (300 cc/min/in at -196°C/ -320°F), Shell 77/200, MSS SP-134, ISO 28921-1.

ZERO FUGITIVE EMISSIONS

NOZ-CHEK® products feature a single piece solid body (no penetrations or external leak paths), reflecting our commitment to environmental responsibility and critically ensuring zero fugitive emissions.

IN-HOUSE CRYOGENIC TESTING

The low temperature and Cryogenic High-Pressure gas testing is carried out on-site in our state of the art testing facilities. Test capability 1" to 72" and test pressures of 22,500 PSI.

INNOVATION OF PROVEN TECHNOLOGY

Dedication to solving our Customers' challenges, longstanding commitment to safety and quality continue to drive our product innovation.

Industry Standards, Specifications and Directives*	
API 598	Valve Pressure Testing and Inspection
ASME B16.34	Pressure/Temperature Ratings
API 6D	Pipeline Valves
API 6A	Specification for Wellhead and Tree Equipment
2014/68/EU	Pressure Equipment Directive
ISO 28921 – 1	International Standards Organisation Cryogenic testing
BS 6364	British Standard Cryogenic testing
MSS SP-134	Manufacturing Standards Society Cryogenic testing
MSS SP-160	Valves for Hydrogen Fluoride(HF) and Alkylation Service
MSS SP - 126	In-Line, Spring-Assisted, Center-Guided Check Valves

*Consult factory for other specification requirements.

NOZ-CHEK® Applications



Oil and Gas Production

- Centrifugal Compressor Discharge
- Fire Water Lines
- Oil/Steam Separation
- Steam and CO2 Injection
- Gas/Oil Gathering Systems
- Flowlines
- Wellheads
- Regasification
- Liquidfaction

Power Generation

- Steam
- Condensate
- Boiler Feed Pumps
- Cooling Towers
- Service Water Recirculators
- River Water Intake
- Nuclear Energy

Petroleum Refining

- Hydrogen
- Cracking
- Steam
- Crude Oil
- Gasoline
- Visbreakers
- Naphtha
- Sulfur
- HF Alkylation service

Petrochemicals

- Ethylene
- Propylene
- Steam
- Reboilers
- Gases
- EO/EG

Chemicals

- Chlorine
- Phosgene
- Aromatics
- Polymers
- Acids
- Air Separation
- Caustics

Water and Wastewater

- Distribution Lines
- Pumping Stations
- Sewage Plant Blower Discharge
- Chemical Treatment
- Fire Protection Systems
- HVAC Systems
- Desalination

Steel/Primary Metals

- Quench Lines
- De-Scaling
- Continuous Casters
- Steam
- Condensate
- Strippers
- Electro-Galvanizing

Pulp and Paper

- Bleaching Lines
- Black Liquor
- Green Liquor
- White Water
- Steam
- Chemical Recovery

Marine

- FPSO
- Oil Tankers
- Tanker Loading Terminals
- Offshore Platforms
- Sub-Sea Manifolds
- Terminal Transfer Lines
- Barge Unloading Lines
- Shipboard Services

Renewables

- Solar Power
- Wave Power
- Green Hydrogen
- Carbon Capture

Gas Transmission

- Compressor Suction/Discharge/Bypass

Typical Cryogenic Applications

- LNG
- Liquefaction Compression Train
- Mixed Refrigerant
- Ethylene Production
- Ethylene Refrigeration
- Air Separation Units
- General Cryogenic compressor protection

Flanged End Dimensional Data - TC / TCS

1 DISC

Standard disc is high strength with minimized weight to provide fast dynamic response. Design minimizes bearing loads, thus lengthens life of bearings and shaft. Offered in a variety of trim materials, with metal or resilient seating.

2 FLOW OUTLET ZONE

Diffuser and body geometry controls the flow path to minimize pressure loss.

3 INTEGRAL SEAT

Provides seating surface for disc and enables bubble-tight seal with resilient materials.

4 FLOW INLET ZONE

Venturi effect maximizes flow impact on disc. Provides streamlined flow when valve is fully open to minimize pressure loss.

5 SPRING

Each valve is designed with a bespoke spring to best meet the specific customer service conditions.

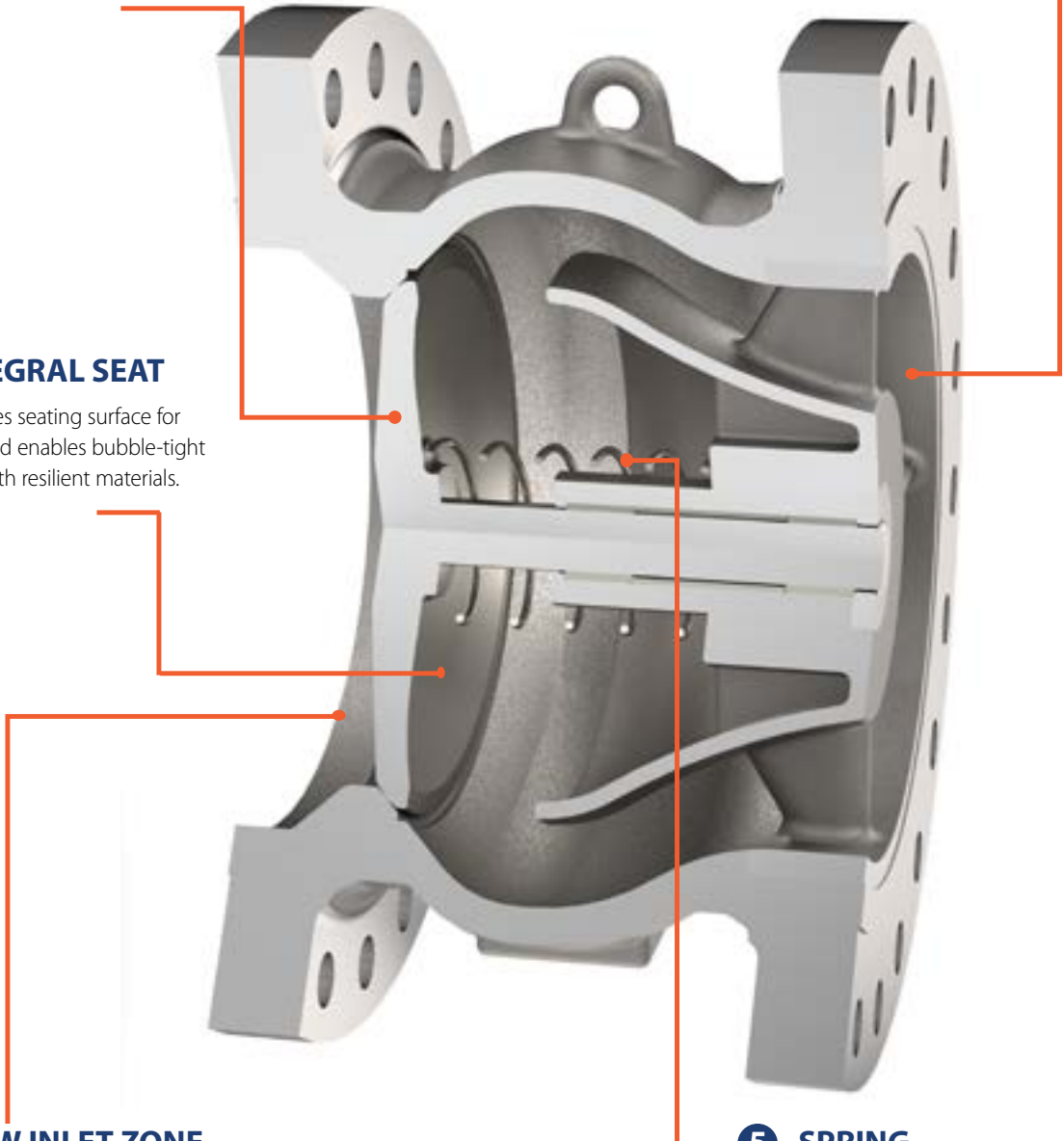

Flanged End Dimensional Data - TC / TCD/ TCV

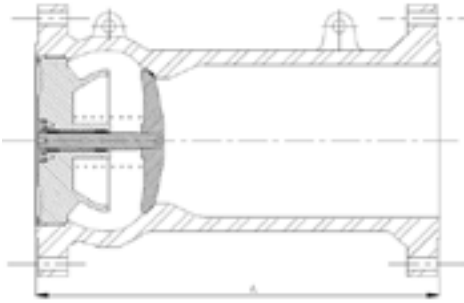

Style **TC**
API 6D Long Pattern

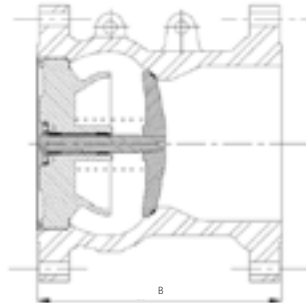

Style **TCD**
API 6D Short Pattern

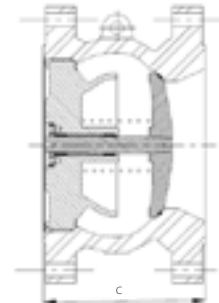

Style **TCV**
Manufacturer's Standard
Pattern

Class 150 RF						
Nominal Size	API 6D Long Pattern	API 6D Short Pattern	Mfr Standard Pattern	Weight		
				A in (mm)	B in (mm)	C in (mm)
2	8.00 (204)	-	-	17.6 (8)	-	-
3	9.50 (241)	-	-	37.4 (17)	-	-
4	11.50 (292)	-	-	63.8 (29)	-	-
6	14.00 (356)	8.27 (210)	-	99 (45)	77 (35)	-
8	19.50 (495)	11.02 (280)	-	176 (80)	136.4 (62)	-
10	24.50 (622)	13.78 (350)	-	357.0 (162)	287.0 (130)	-
12	27.50 (699)	13.78 (350)	-	560.0 (254)	437.0 (198)	-
14	31.00 (787)	15.94 (405)	14.00 (356)	637.0 (289)	465.0 (211)	432.0 (196)
16	34.00 (864)	17.91 (455)	15.00 (381)	807.0 (365)	584.0 (265)	542.0 (246)
18	38.50 (978)	20.47 (520)	16.75 (425)	1063.0 (482)	778.0 (353)	741.0 (336)
20	38.50 (978)	22.44 (570)	17.50 (445)	1294.0 (587)	1003.0 (455)	893.0 (405)
24	51.00 (1295)	26.97 (685)	19.00 (483)	2018.0 (915)	1451.0 (658)	1272.0 (577)
30	60.00 (1524)	33.66 (855)	27.00 (686)	4128.0 (1872)	3142.0 (1425)	2792.0 (1266)
36	77.00 (1956)	40.55 (1030)	30.50 (775)	7036.0 (3191)	5122.0 (2323)	4379.0 (1986)

Class 300 RF						
Nominal Size	API 6D Long Pattern	API 6D Short Pattern	Mfr Standard Pattern	Weight		
				A in (mm)	B in (mm)	C in (mm)
2	10.50 (267)	-	-	24.6 (11.2)	-	-
3	12.50 (318)	-	-	48.4 (22)	-	-
4	14.00 (356)	-	-	85.8 (39)	-	-
6	17.50 (445)	8.27 (210)	-	143.6 (65.3)	112.9 (51.31)	-
8	21.00 (533)	11.02 (280)	-	283.8 (129)	212 (96.5)	-
10	24.50 (622)	13.78 (350)	-	426.0 (193)	355.0 (161)	-
12	28.00 (711)	13.78 (350)	-	675.0 (306)	551.0 (250)	-
14	33.00 (838)	15.94 (405)	14.00 (356)	811.0 (368)	615.0 (279)	591.0 (268)
16	34.00 (864)	17.91 (455)	15.00 (381)	1010.0 (458)	785.0 (356)	739.0 (335)
18	38.50 (978)	20.47 (520)	16.75 (425)	1327.0 (602)	1045.0 (474)	1036.0 (470)
20	40.00 (1016)	22.44 (570)	17.50 (445)	1647.0 (747)	1325.0 (601)	1235.0 (560)
24	53.00 (1346)	26.97 (685)	19.00 (483)	2701.0 (1225)	2018.0 (915)	1852.0 (840)
30	62.75 (1524)	33.66 (855)	27.00 (686)	4981.0 (2259)	3892.0 (1765)	3636.0 (1649)
36	82.00 (2083)	40.55 (1030)	30.50 (775)	8161.0 (3701)	5982.0 (2713)	5479.0 (2485)

Flanged End Dimensional Data - TC / TCD/ TCV

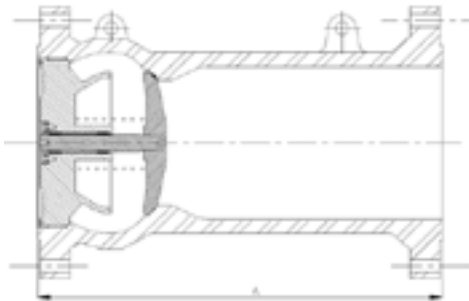

Style TC
API 6D Long Pattern

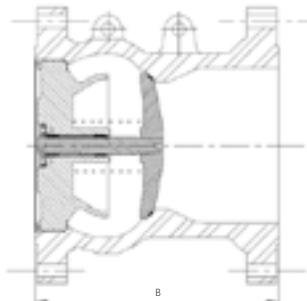

Style TCD
API 6D Short Pattern

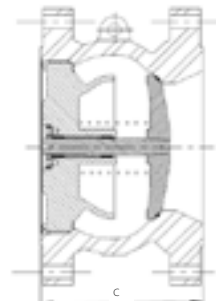

Style TCV
Manufacturer's Standard Pattern

Class 600 RF						
Nominal Size	API 6D Long Pattern	API 6D Short Pattern	Mftr Standard Pattern	Weight		
	A in (mm)	B in (mm)	C in (mm)	A lbs. (kg)	B lbs. (kg)	C lbs. (kg)
2	11.50 (292)	-	-	27.0 (12.5)	-	-
3	14.00 (356)	-	-	54.3 (24.7)	-	-
4	17.00 (432)	-	-	112.6 (51.2)	-	-
6	22.00 (559)	8.27 (210)	-	229.9 (104.5)	169.4 (77)	-
8	26.00 (660)	11.02 (280)	-	393.8 (179)	284.0 (129)	-
10	31.00 (787)	13.78 (350)	-	792.0 (359)	622.0 (282)	-
12	33.00 (838)	14.76 (375)	-	1025.0 (465)	774.0 (351)	-
14	35.00 (889)	17.32 (440)	-	1301.0 (590)	893.0 (405)	-
16	39.00 (991)	19.69 (500)	-	2461.0 (1116)	1874.0 (850)	-
18	43.00 (1092)	22.24 (565)	20.00 (508)	2604.0 (1181)	2115.0 (959)	2062.0 (935)
20	47.00 (1194)	24.61 (625)	20.00 (508)	2767.0 (1255)	2201.0 (998)	2084.0 (945)
24	55.00 (1397)	29.33 (745)	22.50 (572)	4298.0 (1949)	3274.0 (1485)	3001.0 (1361)
30	65.00 (1651)	36.61 (930)	31.00 (787)	7358.0 (3337)	5654.0 (2564)	5316.0 (2411)
36	82.00 (2083)	44.09 (1120)	32.50 (826)	11634.0 (5276)	8423.0 (3820)	7442.0 (3375)

Class 900 RTJ						
Nominal Size	API 6D Long Pattern	API 6D Short Pattern	Mftr Standard Pattern	Weight		
	A in (mm)	B in (mm)	C in (mm)	A lbs. (kg)	B lbs. (kg)	C lbs. (kg)
2	14.63 (371)	-	-	69.1 (31.4)	-	-
3	15.13 (384)	-	-	102.7 (46.7)	-	-
4	18.13 (460)	-	-	169.0 (76.8)	-	-
6	24.13 (613)	9.06 (230)	-	328 (149)	239 (108.8)	-
8	19.13 (740)	11.02 (280)	-	579 (263)	425 (193)	-
10	33.13 (842)	13.78 (350)	-	851 (386)	580 (263)	-
12	38.13 (969)	16.93 (430)	-	1782 (808)	1226 (556)	-
14	40.88 (1038)	15.75 (400)	-	2082 (944)	1458 (661)	-
16	44.88 (1140)	18.50 (470)	-	2624 (1190)	1837 (833)	-
18	48.50 (1232)	20.87 (530)	-	3308 (1500)	2315 (1050)	-
20	52.20 (1332)	23.43 (595)	-	3638 (1650)	2547 (1155)	-
24	61.75 (1568)	26.18 (665)	-	8114 (3680)	6372 (2890)	-

Flanged End Dimensional Data - TC / TCD/ TCV

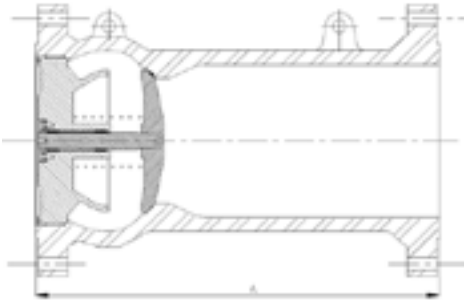

Style **TC**
API 6D Long Pattern

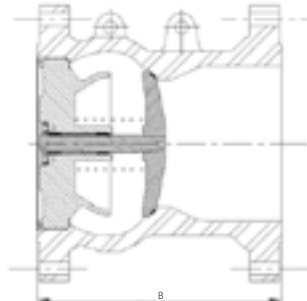

Style **TCD**
API 6D Short Pattern

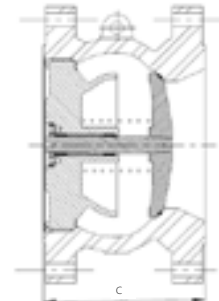

Style **TCV**
Manufacturer's Standard
Pattern

Class 1500 RTJ									
Nominal Size	API 6D Long Pattern	API 6D Short Pattern	Mfr Standard Pattern	Weight					
				A in (mm)	B in (mm)	C in (mm)	A lbs. (kg)	B lbs. (kg)	C lbs. (kg)
2	14.63 (371)	-	-	69.1 (31.4)	-	-	-	-	-
3	18.63 (473)	-	-	137.5 (62.5)	-	-	-	-	-
4	21.63 (549)	-	-	216.5 (98.4)	-	-	-	-	-
6	28.00 (711)	12.20 (310)	-	474.3 (215.6)	360.5 (163.88)	-	-	-	-
8	33.13 (841)	13.78 (350)	-	853.6 (388)	391.6 (278)	-	-	-	-
10	39.38 (1000)	15.75 (400)	-	1874 (850)	725.0 (329)	-	-	-	-
12	45.13 (1146)	17.72 (450)	-	2624 (1190)	1874 (850)	-	-	-	-
14	50.25 (1276)	19.29 (490)	-	3859 (1750)	2701 (1225)	-	-	-	-
16	55.38 (1407)	20.87 (530)	-	4355 (2450)	3872 (1715)	-	-	-	-
18	61.38 (1559)	22.83 (580)	-	6174 (2800)	4322 (1960)	-	-	-	-
20	66.38 (1686)	25.79 (655)	-	8732 (3960)	5918 (2684)	-	-	-	-
24	77.63 (1972)	29.53 (750)	-	13517 (6130)	10209 (4630)	-	-	-	-

Class 2500 RTJ									
Nominal Size	API 6D Long Pattern	API 6D Short Pattern	Mfr Standard Pattern	Weight					
				A in (mm)	B in (mm)	C in (mm)	A lbs. (kg)	B lbs. (kg)	C lbs. (kg)
2	17.88 (454)	-	-	102.1 (46.4)	-	-	-	-	-
3	23.00 (584)	-	-	239.8 (109)	-	-	-	-	-
4	26.88 (683)	-	-	366.7 (166.7)	-	-	-	-	-
6	36.50 (927)	16.93 (430)	-	917.4 (417)	737 (335)	-	-	-	-
8	40.88 (1038)	18.11 (460)	-	1502.6 (683)	1128.6 (513)	-	-	-	-
10	50.88 (1292)	22.83 (580)	-	1837.0 (833)	1268.0 (575)	-	-	-	-
12	56.88 (1445)	22.83 (580)	-	4571 (2073)	2589 (1174)	-	-	-	-

NOZ-CHEK[®] Design Features NC / NCS / NCV

1 DISC

Standard disc is high strength with minimized weight to provide fast dynamic response. Design minimizes bearing loads, thus lengthens life of bearings and shaft. Offered in a variety of trim materials, with metal or resilient seating.

2 FLOW OUTLET ZONE

Geometry controls the flow path to minimize pressure loss.

3 SEAT

Provides seating surface for disc and enables bubble-tight seal with resilient materials.

4 FLOW INLET ZONE

Venturi effect maximizes flow impact on disc. Provides streamlined flow when valve is fully open to minimize pressure loss.

5 SPRING

Each valve is designed with a bespoke spring to best meet the specific customer service conditions.

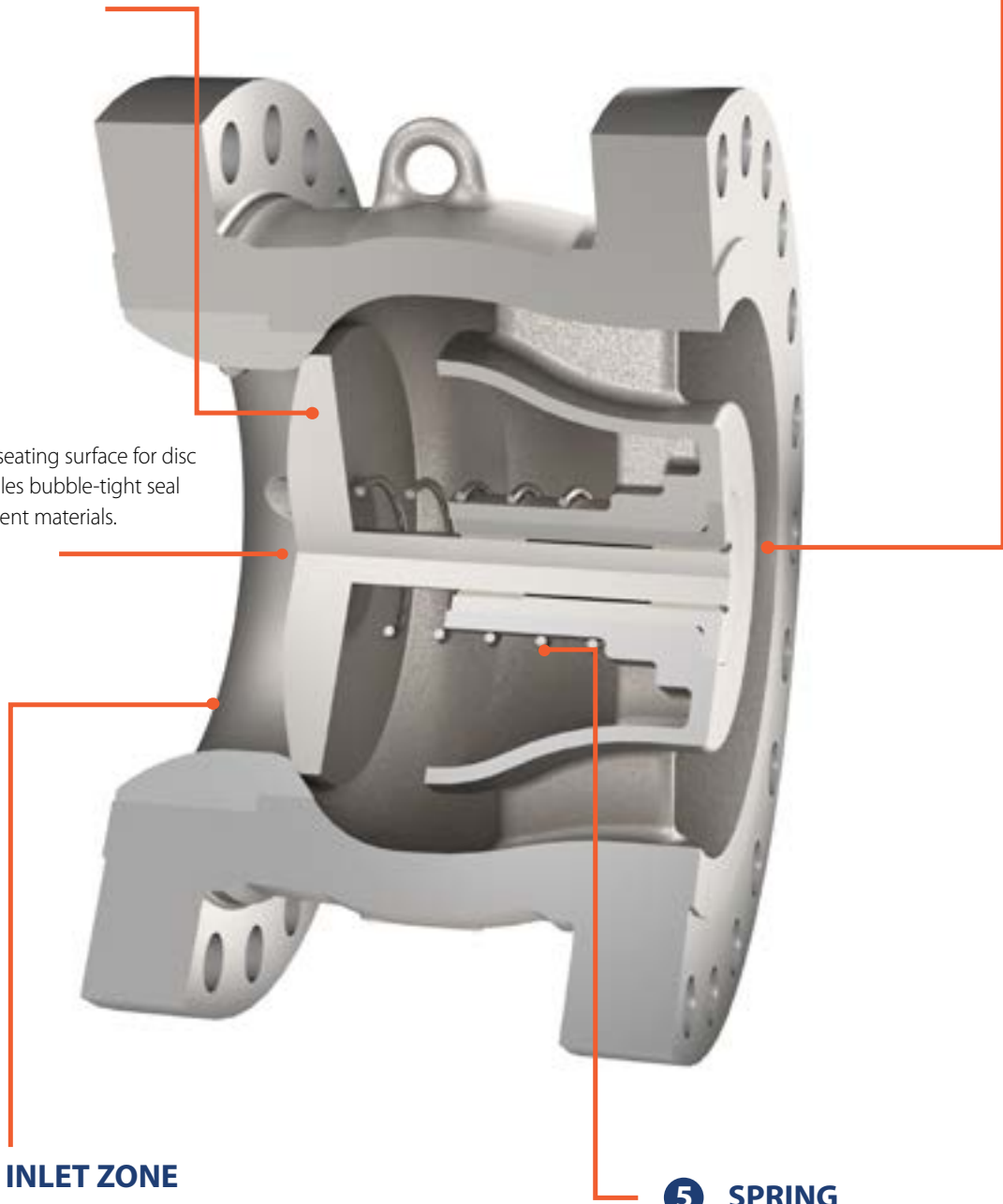

Flanged End - Dimensional Data NCD / NCV

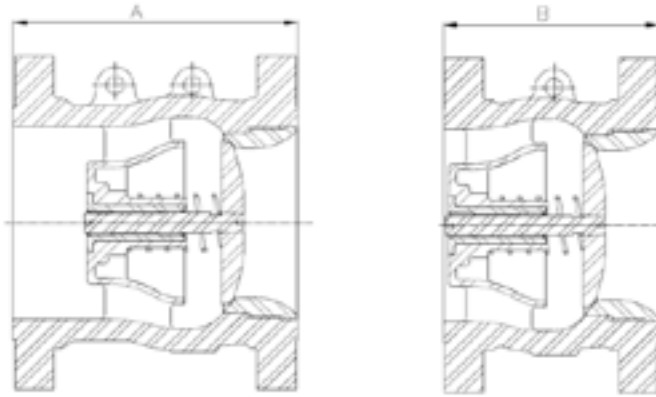

Style **NCD**
Style NCS API 6D Short
Pattern above 36"

Style **NCV**
Manufacturer's Standard
Pattern above 36"

Class 150 RF				
Nominal Size	API 6D Short Pattern	Mftr Standard Pattern	Weight	
	A in (mm)	B in (mm)	A lbs. (kg)	B lbs. (kg)
36	40.55 (1030)	32.00 (813)	4,138 (1880)	3,877 (1762)
42	47.05 (1195)	35.00 (889)	5,529 (2513)	5,060 (2300)
48	53.74 (1365)	38.00 (965)	8,518 (3871)	7,722 (3510)
54	60.24 (1530)	41.00 (1041)	12,260 (5573)	11,286 (5130)
60	67.32 (1710)	45.00 (1143)	13,867 (6303)	13,072 (5942)

Class 300 RF				
Nominal Size	API 6D Short Pattern	Mftr Standard Pattern	Weight	
	A in (mm)	B in (mm)	A lbs. (kg)	B lbs. (kg)
36	40.55 (1030)	32.00 (813)	5,710 (2595)	5,270 (2395)
42	47.05 (1195)	35.00 (889)	9,513 (4323)	8,712 (3960)
48	53.74 (1365)	38.00 (965)	13,621 (6190)	12,283 (5583)
54	60.24 (1530)	41.00 (1041)	14,408 (6550)	12,320 (5600)
60	67.32 (1710)	45.00 (1143)	22,492 (10224)	20,064 (9120)

Class 600 RF				
Nominal Size	API 6D Short Pattern	Mftr Standard Pattern	Weight	
	A in (mm)	B in (mm)	A lbs. (kg)	B lbs. (kg)
36	44.09 (1120)	34.00 (864)	11,213 (5096)	10,252 (4660)
42	51.18 (1300)	32.13 (816)	11,490 (5223)	9,405 (4275)
48	58.46 (1485)	32.13 (816)	15,946 (7248)	12,767 (5803)
54	65.75 (1670)	35.13 (892)	22,357 (10163)	18,656 (8480)
60	73.03 (1855)	46.50 (1181)	32,253 (14660)	26,506 (12048)

Class 900 RF				
Nominal Size	API 6D Short Pattern	Mftr Standard Pattern	Weight	
	A in (mm)	B in (mm)	A lbs. (kg)	B lbs. (kg)
36	41.34 (1050)	36.00 (915)	13,031 (5923)	12,320 (5600)
42	49.21 (1250)	40.00 (1016)	20,297 (7991)	16,115 (7325)
48	57.09 (1450)	44.00 (1,118)	26,000 (11817)	23,305 (10593)

*Note -For other Nominal sizes or special face to face lengths please consult factory

NOZ-CHEK® Quality Management and Testing

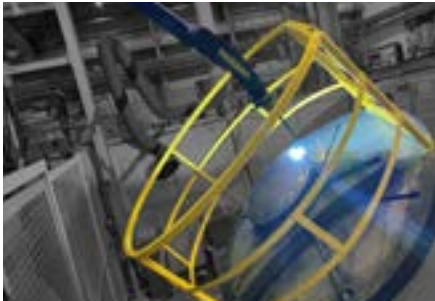

TOTAL QUALITY MANAGEMENT

CRANE is guided by a commitment to total quality management with a focus in customer satisfaction. Cranes Quality Management System is approved to ISO 9001, and certified to Module H of the Pressure Equipment Directive 2014/68/EU

DESIGN

Computer-aided design (CAD) systems at CRANE are helpful in developing sound designs. Finite element analysis is utilized to conduct simulated stress analyses for various valve structures to prove design integrity. Flow modeling is applied to optimize pressure loss characteristics. Computer-aided spring designs and disc weight have improved the NOZ-CHEK® valve response times.

MANUFACTURING CAPABILITIES

NOZ-CHEK® valves can be furnished in sizes from 1- 84" (20 -2100 mm), and in pressure classes from ASME Class 150 - 4500 and API ratings from 2000 -15,000 psi CWP.

A variety of body and trim material is offered, including carbon steel, ductile iron, alloy steels, stainless steel and duplex steel. Coatings may be provided for added corrosion or wear resistance. Hard-facing and weld overlays may also be supplied. Seats may be metal-to-metal or bubble-tight resilient.

TESTING

Inspection and testing are applied throughout the manufacturing process.

- Special nondestructive testing is often specified, which may include radiography, magnetic particle and liquid penetrant.
- Cryogenic and fire tests can be conducted to satisfy customer requirements. The test enclosure is able to test valves up to 72" and to pressures of 22,500 PSI, ensuring extensive coverage of the Crane Engineered Check product range.
- Each valve is hydrostatically tested to API Standard 598. These tests apply to the body shell and seat, with test duration and leakage rates pertaining to customer requirements. Other test standards are also specified in some cases.



Additional Engineered Check Products

Certificates

- ISO 9001
- ISO 14000
- ISO 45000
- API 6D
- PED
- API 6FD/6FA
- CRN
- TR032
- TSG
- API 6FA
- ISO 14644-1 Class 6



STYLE H Retainerless Wafer/ Double Flange/ lug Valves

- Sizes 2" – 84"
- ASME Classes 150 – 2500
- Ring Type Joint, Plain or Serrated Ends
- Carbon Steel, Stainless Steel and Exotic materials



STYLE P Cryogenic Duo-Chek

- Sizes 2"- 36"
- ASME Classes 150-600
 - Designed for cryogenic applications to -196°C



UNI-CHEK® Single-Disc Check Valves

- Sizes 2" – 36"
- ASME Classes 125 – 300
- Flanged, Plain, or Serrated Ends
- Cast Iron, Carbon Steel, and Stainless Steel
- Variety of external shaft options available



STYLE X Extended Body Wafer

- Sizes 10" – 84"
- ASME Classes 150 – 2500
 - Designed for extremely fast opening applications



COMPAC-NOZ® Compact Body Nozzle Check Valves

- Sizes 2" – 48"
- ASME Classes 150 – 2500
- Double Flanged / Lug / Wafer
- Carbon Steel, Stainless Steel, and exotic materials
- ASME, EN, JIS Standards

NOZ-CHEK® Ordering Information

24"	TC	30	S	M	F	9
Valve Size	Style	Pressure Class	Body	Seal	End Connection	Modification Number

Description: ; 24" Non-Integral Diffuser, Standard API 6D Long Pattern, ASME Class 300, Carbon Steel Body, Buna-N Seal, Serrated Raised Face. (Modification number to be assigned at order stage).

VALVE SIZE

Nominal valve sizes are expressed in inches, for ASME and API flange standards or millimeters for EN flange standards. (Size preceded by "M" for EN)

SEAL Operating temperature for general guidance only

Code Letter	Seal Material	Maximum Recommended Operating Temperatures	
		°C	°F
M	Buna-N	-25 to 110	-13 to 130
V	FKM-B	-15 to 200	5 to 392
P	Metal	-257 to 537	-450 to 1000
Z	EPDM	-25 to 120	-49 to 250

Metal seats may be furnished as integral or special overlay materials are available.

STYLE

Ordering Letter	Body Style	Size Range
NCD	Integral Body, Standard API 6D Short Pattern	38" through 60" (950mm through 1500mm)
NCV	Integral Body, Short Body Manufacturer's Pattern	38" through 84" (950mm through 2100mm)
TC	Non-Integral Diffuser, Standard API 6D Long Pattern	1" through 36" (20mm through 900mm)
TCD	Non-Integral Diffuser, Standard API 6D Short Pattern	2" through 36" (50mm through 900mm)
TCV	Non-Integral Diffuser, Short Body Manufacturer's Pattern	10" through 36" (250mm through 900mm)

FLANGE SERIES (ASME B16.47 Series "A" or "B" to be specified over 24") guidance only

ASME	
Ordering No.	Pressure Class
15	150
30	300
60	600
90	900
150	1500
250	2500
450	4500

API	
Ordering No.	Rating
21	2000
31	3000
51	5000
101	10,000
151	15,000

Metric - EN	
Ordering No.	Rating
6	PN6
10	PN10
16	PN16
25	PN25
40	PN40
63	PN63
100	PN100
160	PN160
250	PN250
320	PN320
400	PN400

NOZ-CHEK® Ordering Information

24"	NC	30	S	M	F	9
Valve Size	Style	Pressure Class	Body & Trim	Seal	End Connection	Modification Number

Description: 24" Style NC, ASME Class 300, Carbon Steel Body, Buna-N Seal, Raised Face Flanges
(Modification number to be assigned at order stage.)

STANDARD BODY & DISC MATERIALS

Code	Body	Disc
S	ASTM A 216 GR WCB carbon steel	alloy steel
C	ASTM A 351 GR CF8M 316 stainless steel	stainless steel
DD	BS EN 1563 GR EN-GJS-450-10 ductile iron	stainless steel
GC	ASTM A 352 GR LCC low temp. carbon steel	alloy steel
DZ	ASTM A995 GR 4A duplex stainless steel	Duplex SS

Other high grade and alloy materials are available as cast and forged grades.

SPRING MATERIAL

Spring Material	Maximum Recommended Operating Temperatures	
	°C	°F
316 Stainless Steel	300	572
Inconel® X-750	550	1022

Inconel® is a registered trademark of Special Metals Corporation.
For temperatures up to 700°F (370°C), Inconel X-750 spring temper will be furnished as standard. For higher temperatures the appropriate heat treat will be carried out.
Other alloy spring materials are available to meet specific service requirements.

END CONNECTIONS

Ordering Letter	Connections
F	Flanged, Raised Face, Serrated
X	Special Facing
G	Hub End
P	Flanged, Raised Face, Non-serrated (125 µin Max.)
R	Flange, Flat Face, Ring Joint
W	Butt Weld End

MODIFICATIONS

A modification number is assigned when non-standard features, material mixes or documentation are ordered.

CRANE®

CRANE CHEMPHARMA & ENERGY

4526 Research Forest Drive,
Suite 400
The Woodlands
Texas 77381, U.S.A.
Tel: +1 936 271 6500

Sydney, Australia Operations
146-154 Dunheved Circuit
St. Marys, NSW 2760 Australia
Tel: +61 2 9623 0234

Crane Process Flow
Technologies (India) Ltd
E7 / E8 -2 Old MIDC
Satara - 415 004 India
Tel: +91 2162 244417

Crane Middle East & Africa FZE
PO Box 17415
Jebel Ali Freezone
Dubai, UAE
Tel: +971 4 816 5800

Tanwei Industrial District
West of 2nd Industrial Area
34341 Dammam
Saudi Arabia
Tel: +966 13 895 7058

Crane Company, and its subsidiaries cannot accept responsibility for possible errors in catalogues, brochures, other printed materials, and website information. Crane Company reserves the right to alter its products without notice, including products already on order provided that such alteration can be made without changes being necessary in specifications already agreed. All trademarks in this material are the property of the Crane Company or its subsidiaries. The Crane and Crane brands logotype (ALOYCO®, BAUM®, CENTER LINE®, CRANE®, CRANE CRYOGENICS™, CRYOWORKS®, DEPA® & ELRO®, DOPAK®, DUO-CHEK®, FLOWSEAL®, GYROLOK®, GO REGULATOR®, HOKE®, JENKINS®, KROMBACH®, NOZ-CHEK®, PACIFIC®, RESISTOFLEX®, REVO®, SAUNDERS®, STOCKHAM®, TECHNIFAB®, TEXAS SAMPLING®, WESTLOCK®, WTA®, and XOMOX®) are registered trademarks of Crane Company. All rights reserved.