

NOZ-CHEK[®]

brands you trust.

OPERATION AND MAINTENANCE INSTRUCTIONS

NOZ-CHEK[®] Cryogenic Valves

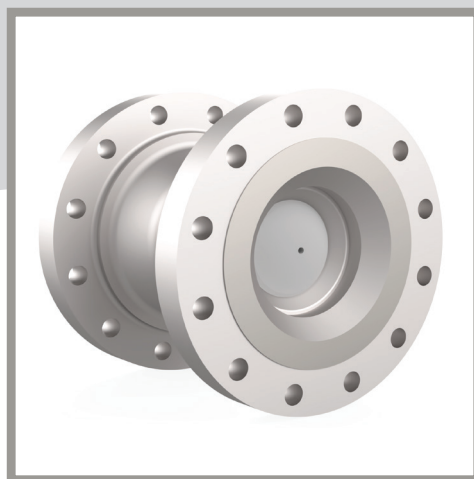

CRANE[®]

Crane ChemPharma & Energy

www.cranecpe.com

1.0 INTRODUCTION AND BACKGROUND

1.1 HIGH PERFORMANCE NON-SLAM CHECK VALVE

Crane Stockham Valve has been an innovative leader in non-return valve design since 1960. The design of modern compression and pumping installation and certain other process applications have a requirement for low pressure drop, rapid response, non-slam check valves.

The Noz-Chek® product is the result of a two year project undertaken by Crane Stockham Valve Engineers in conjunction with Queen's University, Belfast. During this development many hydrodynamic flow and surge tests were performed at their flow laboratory.

Final testing was successfully conducted in the hydraulic machinery laboratory of the Industrial Technology Division of Delft Hydraulics, at Delft Netherlands.

The product of this development is a precision non-return valve which can be placed in critical locations to ensure predictable, non-slam closing times in applications where extremely quick flow reversal is anticipated.

The Noz-Chek® valve range has been designed to meet ASME B16.34 and API 6D specifications. The Crane Stockham Valve manufacturing facility in the UK is approved to ISO 9001, and the Pressure Equipment Directive 2014/68/EU.

The Noz-Chek® is a high performance non-return check valve offering four major benefits for critical service applications:-

- Minimises water hammer in liquid service.
- Removal of chatter associated with conventional valves in reciprocating compressor service.
- Protects rotating equipment from damage due to flow reversal.
- Minimises the pressure loss in the piping.

It optimises the performance between low pressure loss and quick dynamic response, keeping the reverse velocity to a minimum.

Further development and testing of the valve, including updating to state of the art machining techniques and refined material selection, means the Noz-Chek® now fully complies with BS 6364 cryogenic leak rates.

1.2 CRYO NOZ-CHEK® FEATURES

Cryogenic Service

The Cryo Noz-Chek® valve is capable of achieving reduced leak rates of less than 300cc/min/inch at -196°C which fully complies with BS6364 and ISO 28921-1.

Low Pressure Loss

Axial movement of the valve disc allows an ideal streamlined flow path. The valve geometry creates a controlled reduction in flow area, resulting in an increased flow velocity through the valve. The venturi effect allows maximum valve capacity and minimises pressure loss.

Long Valve Life

The Crane Stockham Valve Noz-Chek® is a simple, compact, reliable, well engineered valve. The only moving part is the disc, which has a stem, positively guided through a low friction bearing. Noz-Chek II® components are designed to have a long quiet and dependable life.

Non-Slam Characteristics

Flow velocity into the valve inlet causes the disc to move axially and compresses the valve spring. The valve is fully opened when the inlet velocity has reached the critical velocity. The valve is designed to be in the fully open position with the smallest possible axial movement. When inlet velocity is reduced below critical velocity the compressed spring initiates valve disc closure.

The short stroke, spring assisted disc design minimises valve slam and water hammer.

Spring Options

The Crane Stockham Valve Noz-Chek® is available with different strength springs. The choice of different springs effects critical velocity and valve response. Crane Stockham Valve engineers review each application and make the correct spring selection for each specific application.

NOZ-CHEK® Cryogenic Installation, Operation & Maintenance

2.0 INITIAL COMMISSIONING

A Crane Stockham Valve Noz-Chek® check valve is a precision built product, specifically designed for the operating parameters of your system.

Please observe the following recommendations:

2.1 INITIAL / COMMISSIONING PROCEDURE

- (a) Valves will be packed in accordance with our ESB 2155 APP20, Packing, preservation and site storage procedure for cryo valve products.
- (b) Care should be taken not to damage any paint work, while lifting and moving valves.
- (c) Care should be taken not to damage flange / mating faces of valves.
- (d) Care should be taken to avoid mechanical damage to cable / junction box of the Position Switch during installation of valve and throughout its working life, (if applicable).
- (e) Care should be taken to prevent contamination of the valve from dirt, dust or any other foreign bodies from entering the valve internals.
- (f) Remove any desiccants that have been placed in bore of valve prior to installation.

2.2 STORAGE

The valve shall be stored within a sealed polyethylene bag to prevent any contaminants from entering the valve.

3.0 INSTALLATION

(a) Direction of Flow

The direction of flow should coincide with the flow direction indicated by the cast 'arrow' on the body of the Noz-Chek®.

(b) Operating Orientation

Ensure that the mounting position is in the operating orientation as advised on the Service specification for each valve when ordered i.e. horizontal, vertical upwards or downwards flow.

(c) Line positioning

Ideally the check valve should have 5 diameters of straight pipe before and 6 diameters after the valve. For practical reasons this is often not possible. The valve should have as a minimum, 2 diameters of straight pipe before and after its location. The valve will under normal circumstances still function as a non-slam check

valve if fitted closer to other equipment than the stated guidelines; however this will normally result in increased pressure loss and wear of components. This phenomenon is not exclusive to Crane equipment, and should be applied to any pipe layout as good practice.

The pressure loss of any piece of piping equipment in a system will be affected by the presence of other equipment. Pressure loss is an unrecoverable energy loss and is the measured decrease in pressure. Measuring the pressure drop immediately before and after piping equipment will give a higher reading than measuring a sufficient distance before and after the piping equipment. This is due to pressure recovery after the equipment as the flow returns to the full flow area of the pipe. Standard flow loop testing requires two diameters of straight pipe before the equipment and six after. Most of the pressure recovery will occur in the first three diameters after a nozzle check valve and a significant amount after two diameters.

Two diameters before the piping equipment will allow for the pressure recovery of the upstream equipment. The flow will also lose the increase in turbulence caused by the disruption of the flow by the equipment. Placing equipment too close together will amplify any disruption to the flow and make the overall pressure loss to the system more than the sum of the individual pressure loss of the equipment.

Insufficient straight pipe before the piping equipment can also cause a significant increase in the wear of the components and reduce the life of the equipment. Research has shown that typically five diameters are required to stop the effects of accelerated wear with the affects increasing in an exponential curve. With the geometry of the nozzle check valve it has been shown that two diameters is sufficient to make the affects of the accelerated wear minimal.

(d) Lifting and Flange Assembly

Always lift the valve by the lifting eyes provided, or alternatively a well padded sling.

Ensure that no external pipeline stresses are imposed on the valve prior to tightening bolts and pipework mating flanges are parallel.

Ensure bolts are tightened correctly. Always tighten in a diagonally opposing bolt sequence, to ensure that all bolts apply a uniform load, with the gaskets properly installed.

(e) Welded End Valves

(Bevelled per ASME B16.25 figure 2 (a) or 3 (a) depending on wall thickness).

Valves with end connections prepared for welding into a pipeline should be lowered into position between mating pipe ends after removal of any debris or foreign matter. Ensure proper alignment of valve and pipe.

Temperature rise due to heat conduction along inlet end of valve in proximity of resilient seals should be monitored during welding process to ensure maximum temperature of seals are not exceeded. Refer to General Arrangement drawings for details.

All welding should be performed in accordance with qualified procedures.

(f) Position Switches

Where a valve is fitted with a position switch, the switch must be wired in accordance with the switch datasheet. Ensure that the switch is not exposed to excessive voltage. Care should be taken not to hit the switch housing as this may damage the threads and cause leakage.

4.0 OPERATION

4.1 OPENING

Reduced pressure, generated by increased velocity in the minimal flow area results in additional force to assist the Disc to open and allows for extra spring loading that facilitates a faster closing time.

This spring force is balanced in the fully open position of the disc for a given velocity of flow. This velocity depends upon the flow imposed by the service conditions and the Specific Gravity of the fluid.

The Noz-Chek II® geometry is established by considering the design velocity required to ensure that the disc is stabilised open against its stop even if moderate flow oscillation occurs.

4.2 CLOSING

When the flow through the valve reduces below the critical velocity (velocity when the valve is just 100% open) of the valve, the disc reacts immediately, limiting backflow and valve slamming.

The spring load, disc inertia and short displacement ensures a rapid self-dampening response.

4.3 POSITION SWITCHES

With reference to valves fitted with a position switch, the purpose of the switch is to determine if the disc is in the opened or closed position.

The switch is activated by the presence (close proximity) of a magnetic field, the magnetic field is emitted from a magnet located in the sealing disc, and is sensed by the switch located through the valve wall.

NOZ-CHEK® Cryogenic Installation, Operation & Maintenance

5.0 MAINTENANCE

5.1 GENERAL

Depending on the severity of the application (e.g. flow velocity, cycling, location of valve) maintenance can be scheduled accordingly. A suggested duration is in the range of 5-10 years under average conditions.

This product was built and tested to exacting standards. The following maintenance procedure must be followed with a great deal of care.

If a detailed inspection is required, we can provide a kit of spares and special tools:

Standard Design:

Spares: Spring Energized Seal–(10)–(See figure 1)

Alternative Seal Design:

Spares: Metal C-seal

Special Tools: Seat Extractor (See Figure 2)

Disc Extractor (See Figure 2)

Plus tools normally carried by standard maintenance team.

5.2 POSITION SWITCHES (IF APPLICABLE)

The sensing surfaces of the magnet housing and switch housing should be checked for deposits that could effect the operation of the switch and cleaned if necessary. Also, the magnet housing and switch housing should be checked to ensure that they have not become loose, and the cable checked for wear or damage and replaced if necessary.

The switch (21) may be checked or replaced without removing the switch housing (20) from the valve (1). This will eliminate the need for draining the valve prior to disassembly. Simply unscrew the cable gland (22), whilst preventing the switch housing (20) from moving. The switch spacer (27) and switch (21) may then be removed for inspection. See Figure 3A.

5.3 VALVE DIS-ASSEMBLY (TYPICAL) – SEE FIGURE 1

Ensure that area upstream of seat (2) is clean and free from scale.

Valve should be resting on downstream side (ensuring no damage to sealing face)

Valve may need to be secured to avoid rotation when dis-assembling.

a) Remove seat screw (13) and insert the Seat Extractor tool into the slots in the seat to unscrew the Seat (2) counter clockwise (See Figure 2).

b) Remove set screw (12) and screw the Disc Extractor tool into the tapped hole in the top of the disc (3) to withdraw it (see Figure 2).

c) Remove compression springs (8). Then using a suitable hex head socket, remove the guide housing (4) by turning counter clockwise.

d) Remove retaining rings (6) and extract guide bushes (5)

HEALTH & SAFETY

CAUTION

Caution should be exercised when removing disc as compression of springs could cause ejection of the disc (a weight should be placed upon the disc to avoid injury).

Ensure the appropriate Personal Protective Equipment is used such as safety glasses, gloves and safety shoes.

Ensure surrounding lighting is adequate.

5.4 REPAIRS

Minor repairs can be performed on Seat, Seal and Bushes – lightly emery to remove any bruising. Remove all deposits and debris.

Major repairs such as Seal replacement, Seat Machining etc. would require special equipment. Contact your Crane Stockham Valve representative for further advice.

Spare discs for metal seated valves should be lapped into the mating seat in order to achieve low leakage rates.

Disc Seal Replacement – Disc seals employ a specialist process of applied heat and pressure for bonding rubber to metal and can only be replaced by Crane Stockham Valve.

5.5 VALVE ASSEMBLY

Assemble all components in reverse order to 5.3.

Lubricate generously with suitable 'Anti Seize' compound covering all threaded diameters in both body and seat.

For standard designs: Ensure that the 'Anti Seize' compound is applied around the O-ring in the seat, and on the mating body diameter.

For alternative seat designs: Ensure that none of the 'Anti Seize' compound is applied around the seal area or on the seal itself. The sealing compound can affect the sealing capability at extreme temperatures.

When replacing the guide housing ensure an adequate amount of Furminite (or other suitable locking compound/thread seal) is applied to help lock the guide housing in place.

After assembly of valve, the valve should be hydrostatically tested by pressurising the valve on the downstream side and checking for leakage on the upstream side.

Note:

1. Loctite 222 to be used to secure all screws.
2. Item 11 Back up ring is only required for standard design valves, PN100 and above. (See figure 1)

5.5.1 PROXIMITY SWITCH ASSEMBLY (WHERE APPLICABLE)

(g) Switch housing assembly (See Figure 3B)

1. The threads in the body (1) for the switch housing (20) and the threads on the switch housing (20) should be cleaned thoroughly with petroleum solvent, or other suitable detergent.
2. An even coating of "Jet-Lube" (Thick or Thin) thread paste is applied to the switch housing (20) threads.
3. Screw the switch housing (20) into the body (1) and wrench tighten. (Care must be taken not to start screwing the switch housing in on the incorrect thread as this will damage the threads)
4. The limit switch (21) is inserted fully into the switch housing, and followed by the switch spacer (27).
5. The cable of the limit switch (21) should be passed through the cable gland (22) and the cable gland screwed into the switch housing (20).

(b) Magnet housing assembly (See Figure 4)

1. The 2 magnets (24) are joined together, opposite pole to opposite pole and inserted into the magnet housing (25) (the switch's sensor detects the

presence of a magnetic field, there is no preference in the polarity of the field, therefore the magnet can be inserted into the housing either pole first). Ensure the magnets (24) are positioned in the centre of the magnet housing (25) and secured in place with an anti-vibration sealant (or silicone), such as Belzona 2221 Anti-Shock Compound.

2. The magnet spacer (23) is placed in the magnet housing (25) on top of the magnets (24) so the holes in the spacer and housing are aligned.
3. Insert the magnet housing assembly into the hole in the disc (3) so the hole in the magnet housing (25) and the hole in the disc line up. Secure in place with an anti-vibration sealant (or silicone).
4. An even coating of "Jet-Lube" (Thick or Thin) thread paste is applied to the grub screw (26), which is screwed into the hole in the back of the disc (3) and tightened to secure the magnet housing (25) into the disc (3).

A small portion of the magnet housing (25) will protrude from the hole when fully inserted. This portion should not impede the axial motion of the disc (3) by colliding with the switch housing (20).

5.6 PROXIMITY SWITCH DISASSEMBLY

The disassembly of the Proximity Switch can be accomplished by simply reversing the assembly instructions in 5.5.1.



CAUTION

**ALL THREADS MUST BE CORRECTLY TIGHTENED AND LOCKED.
DO NOT USE EXCESSIVE FORCE AT ANY POINT DURING ASSEMBLY.
IF IN DOUBT DIS-ASSEMBLE AND CHECK BEFORE RE-ASSEMBLY.
REMEMBER: PLEASE USE EYE PROTECTION.**

NOZ-CHEK[®] Cryogenic Installation, Operation & Maintenance

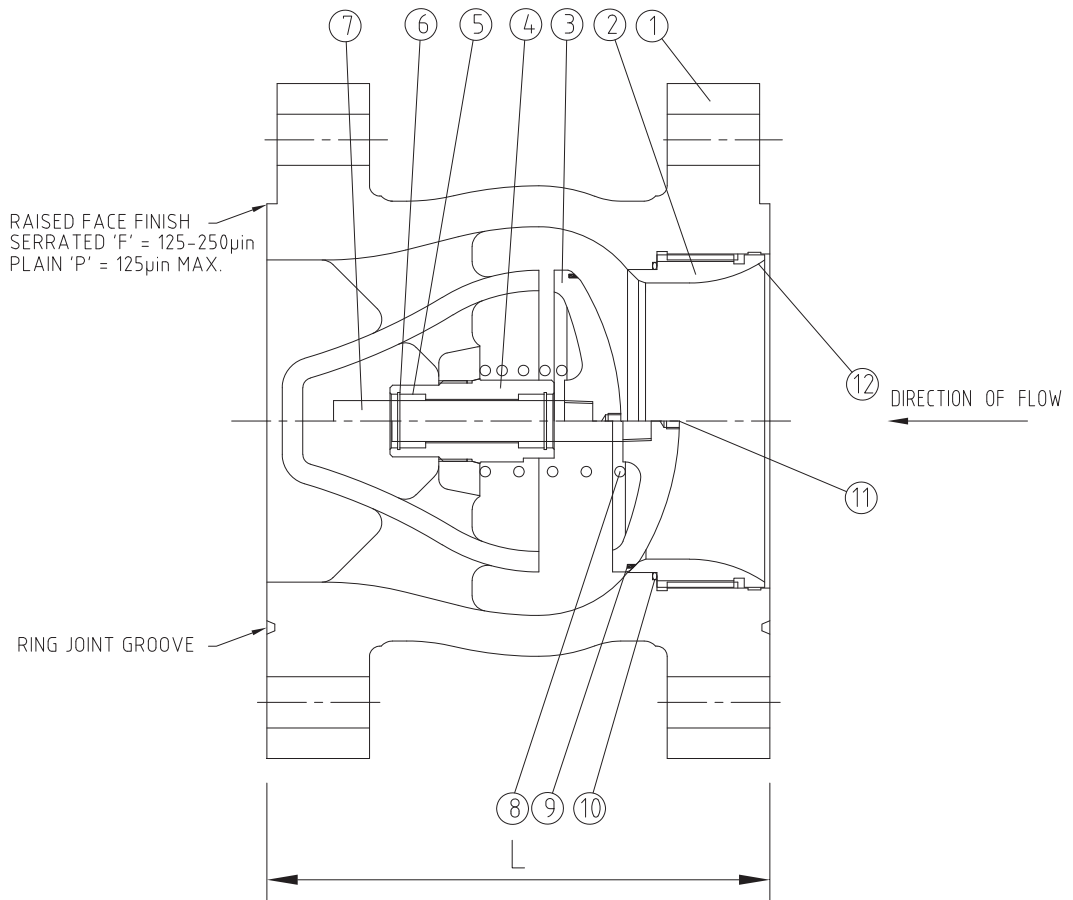

FIGURE 1

Item	Quantity	Description
1	1	BODY
2	1	NOZZLE SEAT
3	1	VALVE DISC
4	1	GUIDE HOUSING
5	2	GUIDE BUSH
6	2	RETAINING RING
7	1	DISC STEM
8	1	SPRING
9	1	SEAL
10	1	SPRING ENERGISED SEAL
11	1	SCREW (DISC)
12	1	SCREW (SEAT)

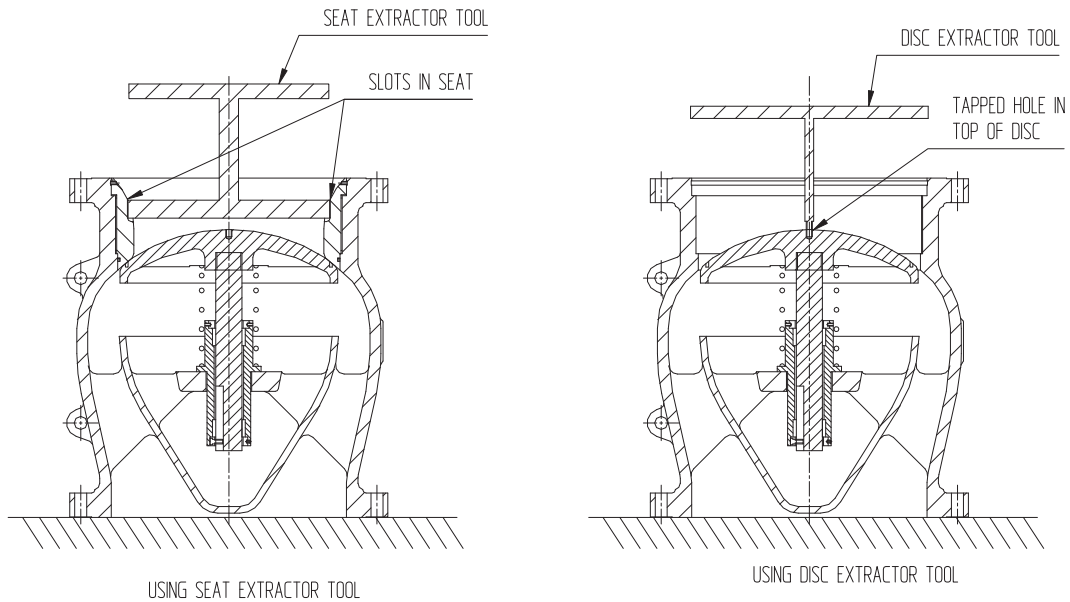

FIGURE 2

NOZ-CHEK® Cryogenic Installation, Operation & Maintenance

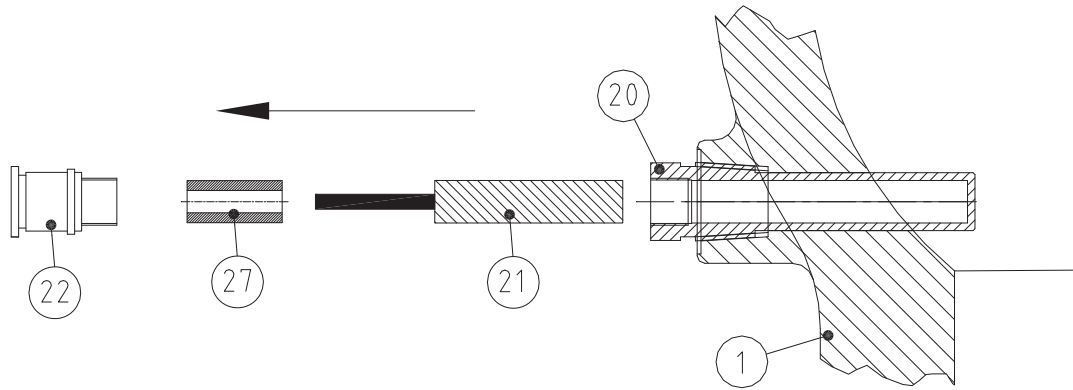

FIGURE 3A

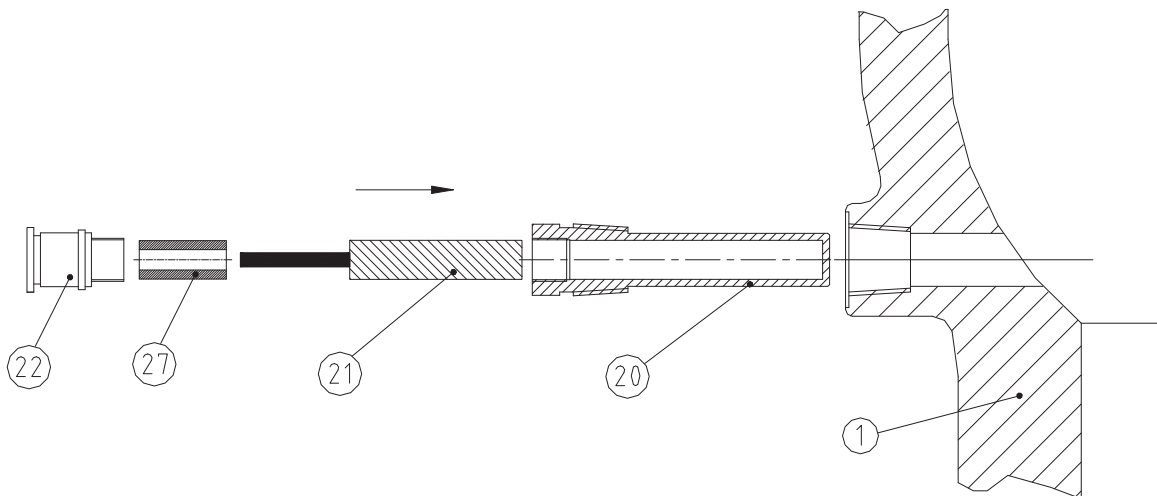

FIGURE 3B

Item	Quantity	Description
1	1	BODY
20	1	SWITCH HOUSING
21	1	SWITCH
22	1	GLAND
27	1	SWITCH SPACER

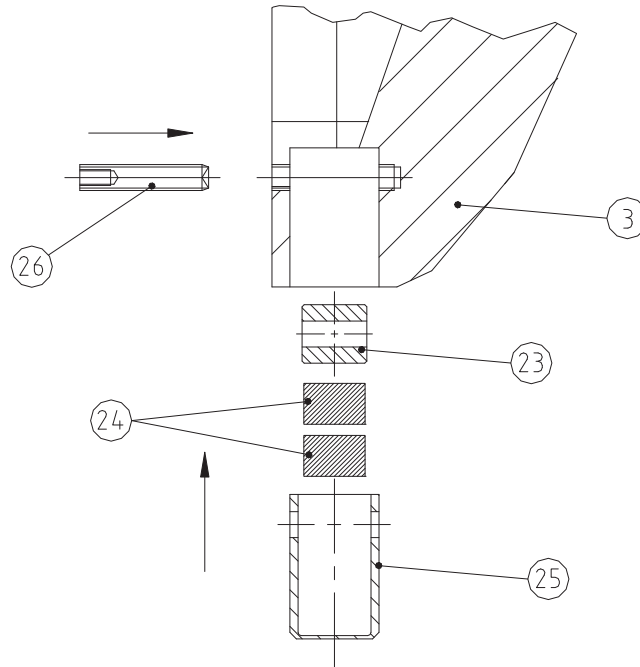

FIGURE 4

Item	Quantity	Description
3	1	VALVE DISC
23	1	MAGNET SPACER
24	2	MAGNETS
25	1	MAGNET HOUSING
26	1	GRUB SCREW

NOZ-CHEK® Cryogenic Installation, Operation & Maintenance

6.0 FAULT FINDING AND CORRECTION

One should keep in mind the purpose of the Noz-Chek® when operating difficulties are encountered. The valve is supposed to check reverse flow. When the valve fails to perform this function, the following points should be checked:

6.1 The valve fails to check

- a) Spring may be broken.
- b) Corrosion may have destroyed all or part of the Disc. This would indicate that the disc material is incorrect for the media.
- c) Debris in the line may prevent the disc from closing.
- d) If the valve is fitted with a switch, the grub screw (26) may have become loose or screwed out and the magnet housing (25) is impeding the disc's (3) movement. To remedy this, clean both threads thoroughly, apply an even coat of "Jet Lube Thick or Thin" thread paste to the threads, and screw the grub screw (26) back into the hole in the disc (3) and magnet housing (25) and tighten.

6.2 The valve slams violently when flow reverses

- a) The spring in the valve is broken and hence does not perform its function.
- b) The spring is too weak. Some flow conditions require the valve to close quicker than others. Unless the disc closes before backflow occurs, possible slamming will result. A stronger spring will help remedy this problem.

6.3 The valve leaks excessively across seal

- a) The seal is defective.
- b) Disc is not seating properly.
- c) The Spring Energised seal (or Metal C-Seal) may be damaged.
- d) If the valve is fitted with a switch, the grub screw may have become loose and the magnet housing is impeding the disc's movement. To remedy this, clean both threads thoroughly, apply an even coat of "Jet Lube Thick or Thin" thread paste to the threads, and screw the grub screw (26) back into the hole in the disc (3) and magnet housing (25) and tighten.

6.4 The valve leaks between the flange faces

- a) The serrations on either the Noz-Chek II® flange or the companion flange are damaged.
- b) A new gasket or seal ring is needed.

6.5 There is no flow through the line

- a) The valve is installed backwards.
- b) The valve is new and the disc has not been broken loose from the valve seat.

6.6 The switch is not working (if fitted)

- a) Ensure switch is connected to relevant system properly, check the cable for wear or damage and replace if necessary. Also check that the system has power.
- b) The magnet housing may have become loose and is impeding the disc's movement. To remedy this, clean both threads thoroughly, apply an even coat of "Jet Lube Thick or Thin" thread paste to the threads, and screw the grub screw (26) back into the hole in the disc (3) and magnet housing (25) and tighten.
- c) Check for deposits on the sensing surfaces of the magnet housing and switch housing that could effect the operation of the switch and clean if necessary.

NOZ-CHEK®

Crane ChemPharma & Energy

Crane Energy Global Headquarters
4526 Research Forest Drive, Suite 400
The Woodlands, Texas 77381 U.S.A.
Tel: +1 936 271 6500
Fax: +1 936 271 6510

Crane Stockham Valve Ltd.
6 Alexander Road
Cregagh, Belfast BT6 9HJ, Northern Ireland
Tel: +44 2 890 704222
Fax: +44 2 890 401582

www.cranecpe.com

Sydney, Australia Operations
146-154 Dunheved Circuit
St. Marys, NSW 2760 Australia
Tel: +61 2 9623 0234
Fax: +61 2 9673 3870

Xomox Chihuahua, S.A.
Juan Ruiz de Alarcón 313,
Complejo Industrial Chihuahua,
31136 Chihuahua, Mexico
Tel: +52 614 442 9860

Crane Process Flow Technologies (India) Ltd
E7 / E8 -2 Old MIDC
Satara - 415 004 India
Tel: +91 21 62244417
Fax: +91 21 62245126

brands you trust.



COMPAC-NOZ®



DEPA®

ELRO®

DUO-CHEK®



NOZ-CHEK®



RESISTOFLEX®



Saunders®
the science inside

STOCKHAM®



UNI-CHEK®

W.T.A.®

XOMOX®

CPE-NOZ-CHEK-CRYOGENIC-IM-EN-A4-2020_08_26

Crane Co., and its subsidiaries cannot accept responsibility for possible errors in catalogues, brochures, other printed materials, and website information. Crane Co. reserves the right to alter its products without notice, including products already on order provided that such alteration can be made without changes being necessary in specifications already agreed. All trademarks in this material are property of the Crane Co. or its subsidiaries. The Crane and Crane brands logotype, in alphabetical order, (ALOYCO®, CENTER LINE®, COMPAC-NOZ®, CRANE®, DEPA®, DUO-CHEK®, ELRO®, FLOWSEAL®, JENKINS®, KROMBACH®, NOZ-CHEK®, PACIFIC VALVES®, RESISTOFLEX®, REVO®, SAUNDERS®, STOCKHAM®, TRIANGLE®, UNI-CHEK®, W.T.A., and XOMOX®) are registered trademarks of Crane Co. All rights reserved.