



KROMBACH® TUFSEAT™ Performance Series Ball Valves



NEW! REVOLUTIONARY SEAT DESIGN RESULTS IN **50%** LONGER LIFE

Combining critical safety and performance features required for demanding service applications in chemical and refining markets.

1 LONGER SERVICE LIFE

Consistent seat leak performance and torque throughout the life of the valve for **HIGH CYCLE AND SLURRY APPLICATIONS**.

2 LOW OPERATING TORQUE

Reduced initial investment cost of automation through **HIGH EFFICIENCY PACKING** and **LIVE LOADED SEATS**.

3 OUTPERFORMS SEAT LEAK STANDARDS*

Bi-directional, class V or VI seat leakage (API-598/FCI 70.2) at elevated pressure and temperature through **PRECISION LAPPING**.

TUFSEAT
THE SUPERIOR*
METAL SEATED
BALL VALVE

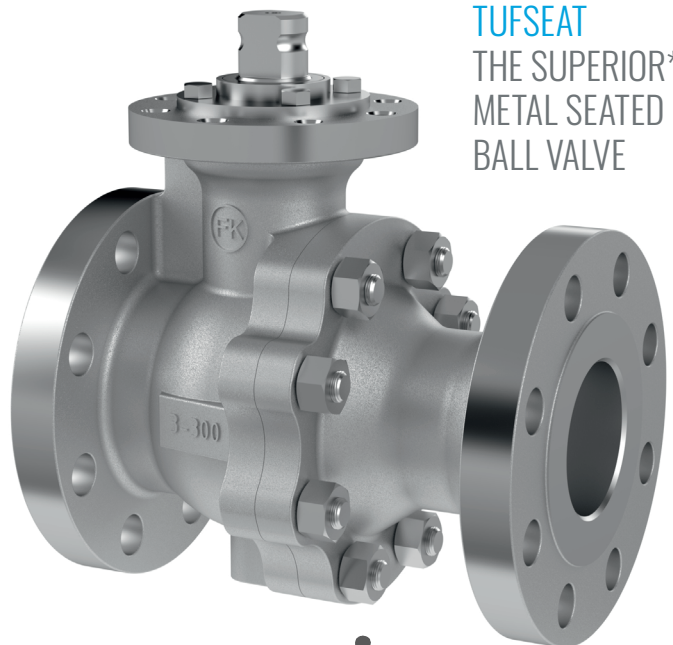

CRANE

v in www.cranecpe.com

KROMBACH® TUFSEAT™ Features and Benefits

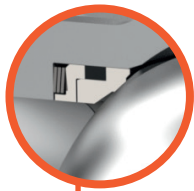

Precision lapping of the metal ball and seat provides sealing integrity, assuring **TIGHT SEALING** even at low pressure, seat geometry creates a scraper self-cleaning effect, and seat springs offset the effects of thermal expansion for **LOWER CONSTANT TORQUE**.

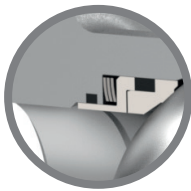

Optional seats with graphite wiper rings for abrasive services, catalyst, slurries and other viscous fluids to protect internal components from seizing and **EXTEND THE LIFE** of the valve.

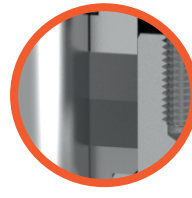

Fully adjustable graphite packing arrangement provide Fire Safe protection without excessive friction for **LOWER TORQUE OPERATION**.



A secondary independent Spring-Energized lip seal compensates for any wear, manufacturing tolerance or eccentricity and provides live loading of the stem seal to **EXTEND THE LIFE** of the packing system.

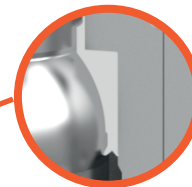

The patented pressure assisted SX stem seal provides the highest protection against fugitive emissions while supplying side-load protection further enhancing the longer life of the packing.

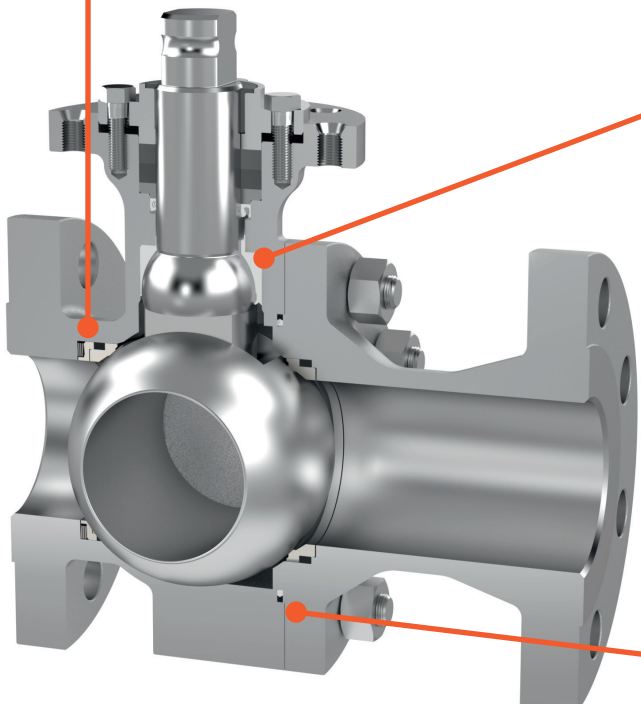

Alternatively, for higher temperature applications, Krombach offers a graphite packing arrangement with metallic diffusion barrier rings to ensure the highest levels of fugitive emissions containment without sacrificing **LOW TORQUE OPERATION** and Fire Safe protection.



To also protect the packing set and ensure **LONG LIFE**, a high density graphite ring further supports the stem against misalignments and assists in eliminating fugitive emissions.

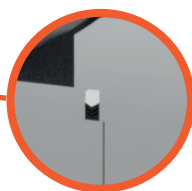
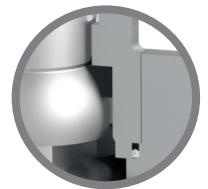

To avoid the effects of pressure and temperature fluctuation, spiral wound dual material body gaskets are standard in KROMBACH® TUFSEAT™ Performance series with an inert PTFE inner seal and fire proof external graphite seal and a full graphite option for high temperature applications and **LONGER LIFE** without static leaks.

Configurations & Sizes

Design	Pressure Rates									Sizes														
	ASME Class	150		300		600	900	1500	2500	4500	ASME NPS	½"	¾"	1"	1½"	2"	3"	4"	6"	8"	10"	12"	14"	16"
	DIN PN	10	16	25	40	100	150	250	420	720	DIN DN	15	20	25	40	50	80	100	150	200	250	300	350	400
Floating		●	●	-	-	-	-	-	-		●	●	●	●	●	●	●	●	-	-	-	-	-	-
Trunnion		●	●	-	-	-	-	-	-		-	-	-	-	-	-	-	-	●	●	●	-	-	-

CRANE CHEMPHARMA & ENERGY
Friedrich Krombach GmbH
Armaturenwerke
Marburger Str. 364
57223 Kreuztal, Germany
Tel.: +49 2732 520 00

Crane Co., and its subsidiaries cannot accept responsibility for possible errors in catalogues, brochures, other printed materials, and website information. Crane Co. reserves the right to alter its products without notice, including products already on order provided that such alteration can be made without changes being necessary in specifications already agreed. All trademarks in this material are the property of the Crane Co. or its subsidiaries. The Crane and Crane brands logotype (CENTER LINE®, COMPAC-NOZ®, CRANE®, DEPA® & ELRO®, DOPAK®, DUO-CHEK®, FLOWSEAL®, GYROLOK®, GO REGULATOR®, HOKE®, JENKINS®, KROMBACH®, NOZ-CHEK®, PACIFIC VALVES®, RESISTOFLEX®, REVO®, SAUNDERS®, STOCKHAM®, TEXAS SAMPLING®, TRIANGLE®, UNI-CHEK®, VALVES®, WESTLOCK CONTROLS®, WTA®, and XOMOX®) are registered trademarks of Crane Co. All rights reserved.