



TECHNICAL DATASHEET

ASME DESIGN

KROMBACH® TUFSEAT® Performance Series Ball Valves

TUFSEAT by KROMBACH - THE SUPERIOR MSBV

CRANE[®]

v in www.cranecpe.com

Features and Benefits

KROMBACH® TUFSEAT® PERFORMANCE SERIES

The KROMBACH® TUFSEAT® Ball Valve Performance Series combines critical safety and performance features required for demanding service applications in chemical and refining markets.

STANDARD DESIGN

- Class V seat leak performance
- Up to 500F / 260°C
- Up to 10% Solids
- Hard Chrome or Nickel Alloy coatings on ball and seats
- Design acc. to ASME B16.34
- Floating Ball: KFO 1176 (1/2" to 6" / 150# and 300#)
- Trunnion: KFO 9176 (8" to 12" / 150# and 300#)

HIGH TEMPERATURE TRIM DESIGN

- Class VI seat leak performance
- Up to 800F/ 427°C
- Up to 20% Solids
- Nickel Alloy, Chrome and Tungsten Carbide coatings on ball and seats available
- Floating Ball: KFO1156 (1/2" to 6" / 150# and 300#, 1/2" to 1-1/2" 600# and 900#)
- Trunnion: KFO 9156 (2" to 12" / 150#, 300#, 600# and 900#)



Product Range

Size	Class	Body Design	Face-to-Face Dimension	Body Material
1/2"-6"	Class 150-300	2-piece design Flanged Floating Ball	ASME B16.10 Long Pattern EN 558-1 Series 12 & 14	WCB / 1.0619 CF8M / 1.4408
1/2"- 1 1/2"	Class 600-900			
8"-12"	Class 150-300	2-piece design Flanged Trunnion Design		
2"-12"	Class 600-900			

Floating Ball Design

Lever Design

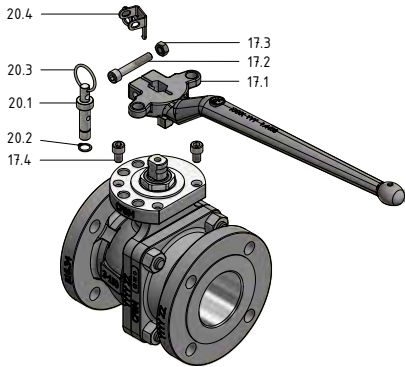

Item	Quantity	Description	Carbon Steel		Stainless Steel	
			ASTM	DIN	ASTM	DIN
17.1	1	Hand lever	A351 CF8M	1.4408	A351 CF8M	1.4408
17.2	1	Hex socket head cap screw	316SS	A4-70	316SS	A4-70
17.3	1	Hex nut	316SS	A4	316SS	A4
17.4	2	Hex socket head cap screw	316SS	A4-70	316SS	A4-70
20.1	1	Locking pin	AISI 316	1.4401	AISI 316	1.4401
20.2	1	Retaining ring	-	1.4122	-	1.4122
20.3	1	Ring	AISI 301	1.431	AISI 301	1.4310
20.4	1	Locking plate	316 Ti	1.4571	316 Ti	1.4571

Press Nut Design

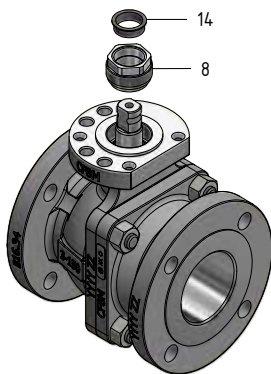

Item	Quantity	Description	Carbon Steel		Stainless Steel	
			ASTM	DIN	ASTM	DIN
8	1	Press nut	A275 Gr. 431	1.4057	A275 Gr. 431	1.4057
14	1	Guide bushing	PTFE - Carbon filled	PTFE - Carbon filled	PTFE - Carbon filled	PTFE - Carbon filled

Sizes 1/2-150# to 3"-150# and 1/2"-300# to 2"-300# and 1/2-600# to 1 1/2-600# and 1/2-900# to 1 1/2-900#.

Packing Gland Design

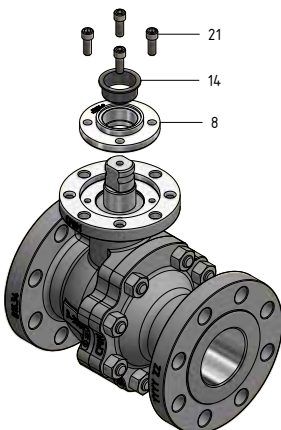

Item	Quantity	Description	Carbon Steel		Stainless Steel	
			ASTM	DIN	ASTM	DIN
8	1	Packing gland	A479 316Ti; 316SS	1.4571; 1.4401	A479 316Ti; 316SS	1.4571; 1.4401
14	1	Guide bushing	PTFE - Carbon filled	PTFE - Carbon filled	PTFE - Carbon filled	PTFE - Carbon filled
21	4	Hex socket head cap screw	A193 B8M Class 2	A4-70	A193 B8M Class 2	A4-70

Sizes 4"-150# to 6"-150# and 3-300# to 6"-300#

Floating Ball Design Standard Trim Class 150-300

Floating Ball Design

Item	Quantity	Description	Carbon Steel		Stainless Steel	
			ASTM	DIN	ASTM	DIN
1	1	Body	A216 WCB	1.0619	A351 CF8M	1.4408
2	1	Tail	A216 WCB	1.0619	A351 CF8M	1.4408
3	1	Ball	A182 F316L+coating	1.4404+coating	A182 F316L+coating	1.4404+coating
4	1	Stem	A276 Gr.431	1.4057	A276 Gr.431	1.4057
5	1	Body gasket	PTFE/Graphite/316Ti	PTFE/Graphite/1.4571	PTFE/Graphite/316Ti	PTFE/Graphite/1.4571
6	2	Seat	A182 F316L +coating	1.4404+coating	A182 F316L +coating	1.4404+coating
7	1	SX Stem seal	TFM	TFM	TFM	TFM
8	1	Packing gland	A479 316Ti, 316SS	1.4571, 1.4401	A479 316Ti, 316SS	1.4571, 1.4401
9	1	Support Ring	A479 316Ti, 316SS	1.4571, 1.4401	A479 316Ti, 316SS	1.4571, 1.4401
10	4	Stud	A193 Gr.B7	1.7225	A193 Gr.B8M Cl.2	A4-70
11	4	Heavy hex nut	A194 Gr.2H	1.7225	A194 Gr.8M	A4-70
12	1	Spring energized lip seal	PTFE - Carbon+Graphite filled / AISI 301	PTFE-Carbon+Graphite filled/ 1.4310	PTFE - Carbon+Graphite filled / AISI 301	PTFE - Carbon+Graphite filled / AISI 301
13	1	Packing set	Graphite	Graphite	Graphite	Graphite
14	1	Guide bushing	PTFE - Carbon filled	PTFE - Carbon filled	PTFE - Carbon filled	PTFE - Carbon filled
21	4	Hex socket head cap screw	A193 B8M Class 2	A4-70	A193 B8M Class 2	A4-70
40	2	Seal ring	Graphite	Graphite	Graphite	Graphite
41	1	Wave spring	17-7 PH	1.4568	17-7 PH	1.4568
42	1	S-Ring	F51, A276 UNS S31803, A276 316L, A276 316Ti	1.4462, 1.4404, 1.4571	F51, A276 UNS S31803, A276 316L, A276 316Ti	1.4462, 1.4404, 1.4571

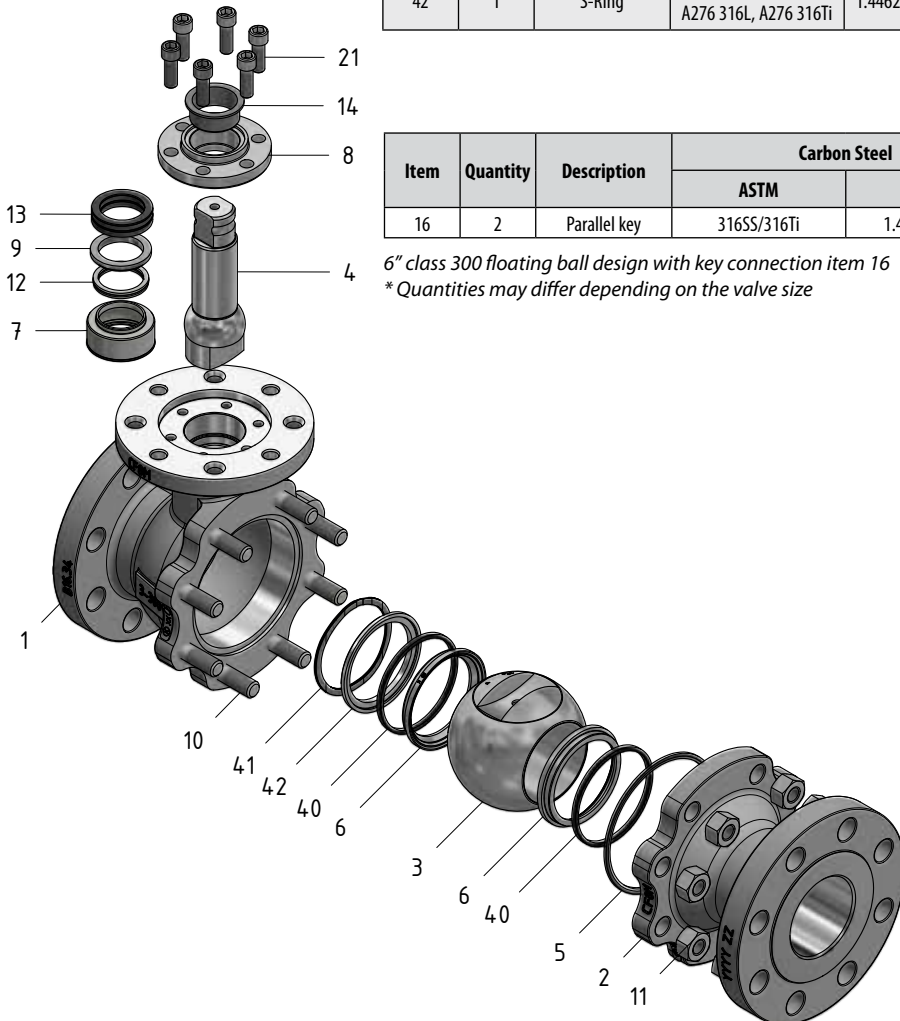

Item	Quantity	Description	Carbon Steel		Stainless Steel	
			ASTM	DIN	ASTM	DIN
16	2	Parallel key	316SS/316Ti	1.4571, 1.4401	316SS/316Ti	1.4571, 1.4401

6" class 300 floating ball design with key connection item 16
*Quantities may differ depending on the valve size

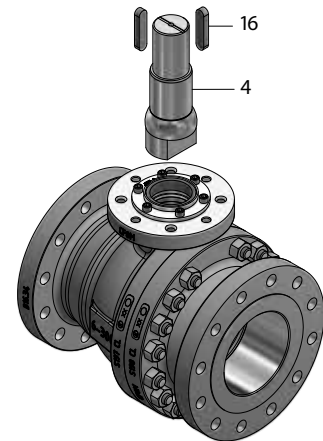

Trunnion Design Standard Trim Class 150-300

Trunnion Design

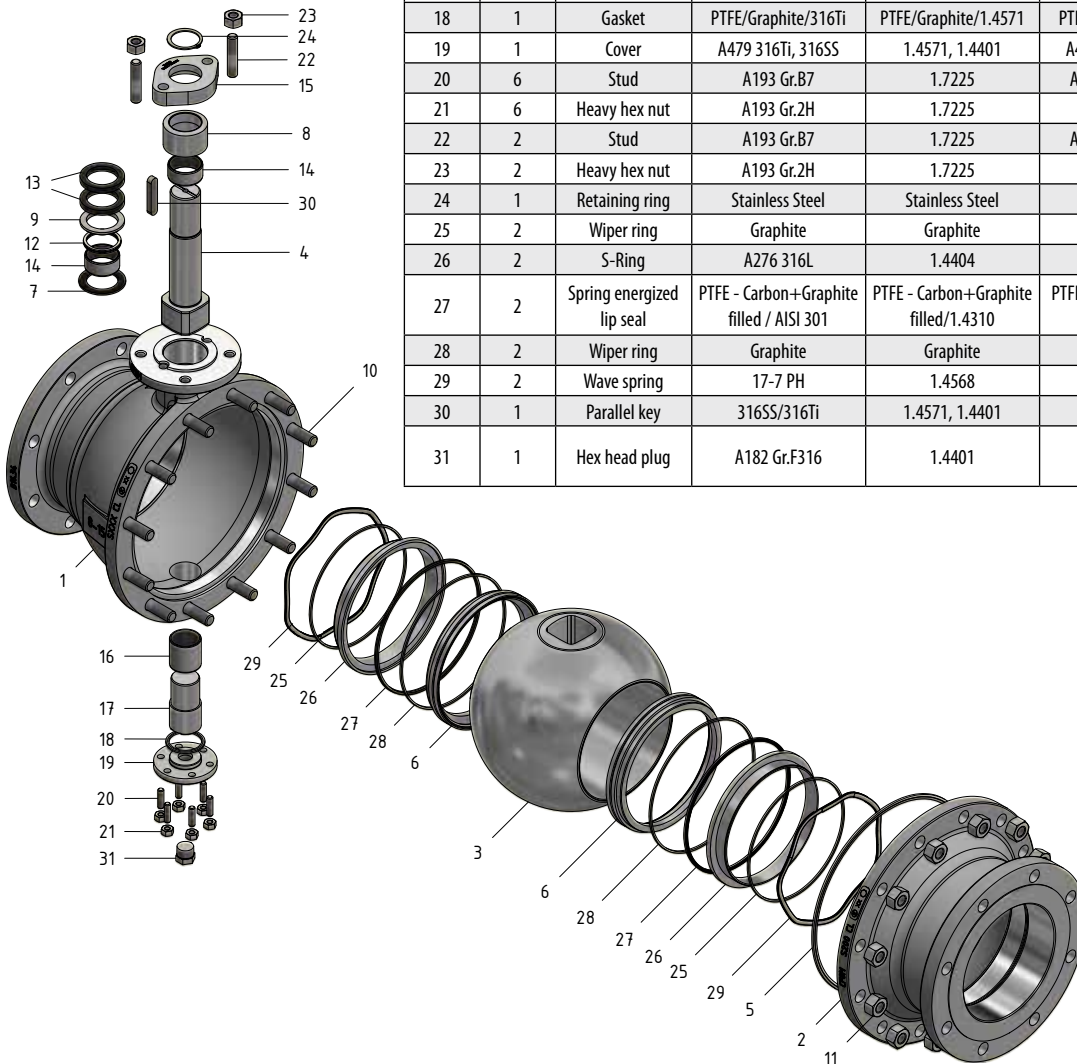

Item	Quantity	Description	Carbon Steel		Stainless Steel	
			ASTM	DIN	ASTM	DIN
1	1	Body	A216 WCB	1.0619	A351 CF8M	1.4408
2	1	Tail	A216 WCB	1.0619	A351 CF8M	1.4408
3	1	Ball	A351 CF8M+ coating, A182 F316L+ coating	1.4408 +coating, 1.4404 +coating	A351 CF8M+ coating, A182 F316L+ coating	1.4408+ coating, 1.4404+ coating
4	1	Stem	A276 Gr.431	1.4057	A276 Gr.431	1.4057
5	1	Body gasket	PTFE/Graphite/316Ti	PTFE/Graphite/1.4571	PTFE/Graphite/316Ti	PTFE/Graphite/1.4571
6	2	Seat	A182 F316L+ coating	1.4404+ coating	A182 F316L+ coating	1.4404+ coating
7	1	Thrust washer	Inconel 625+ coating	Inconel 625+ coating	Inconel 625+ coating	Inconel 625+ coating
8	1	Gland	A582 303	1.4305	A582 303	1.4305
9	1	Support Ring	A479 316Ti, 316SS	1.4571, 1.4401	A479 316Ti, 316SS	1.4571, 1.4401
10	12	Stud	A193 Gr.B7	1.7225	A193 Gr.B8M Cl.2	A4-70
11	12	Heavy hex nut	A193 Gr.2H	1.7225	A194 Gr.8M	A4-70
12	1	Spring energized lip seal	PTFE - Carbon+Graphite filled / AISI 301	"PTFE - Carbon+Graphite filled/1.4310"	PTFE Carbon+Graphite Filled/ AISI 301	PTFE - Carbon+Graphite filled/1.4310
13	1	Packing set	Graphite	Graphite	Graphite	Graphite
14	2	Sleeve bearing	316L+ coating	1.4404+ coating	316L+ coating	1.4404+ coating
15	1	Gland flange	A516 Gr.70	1.0425	A240 316Ti, 316SS	1.4571, 1.4401
16	1	Sleeve bearing	316L+ coating	1.4404+ coating	316L+ coating	1.4404+ coating
17	1	Bottom stem	A479 316Ti, 316SS	1.4571, 1.4401	A479 316Ti, 316SS	1.4571, 1.4401
18	1	Gasket	PTFE/Graphite/316Ti	PTFE/Graphite/1.4571	PTFE/Graphite/316Ti	PTFE/Graphite/1.4571
19	1	Cover	A479 316Ti, 316SS	1.4571, 1.4401	A479 316Ti, 316SS	1.4571, 1.4401
20	6	Stud	A193 Gr.B7	1.7225	A193 Gr.B8M Cl.2	A4-70
21	6	Heavy hex nut	A193 Gr.2H	1.7225	A194 Gr.8M	A4-70
22	2	Stud	A193 Gr.B7	1.7225	A193 Gr.B8M Cl.2	A4-70
23	2	Heavy hex nut	A193 Gr.2H	1.7225	A194 Gr.8M	A4-70
24	1	Retaining ring	Stainless Steel	Stainless Steel	Stainless Steel	Stainless Steel
25	2	Wiper ring	Graphite	Graphite	Graphite	Graphite
26	2	S-Ring	A276 316L	1.4404	A276 316L	1.4404
27	2	Spring energized lip seal	PTFE - Carbon+Graphite filled / AISI 301	PTFE - Carbon+Graphite filled/1.4310	PTFE Carbon+Graphite Filled/ AISI 301	PTFE - Carbon+Graphite filled/1.4310
28	2	Wiper ring	Graphite	Graphite	Graphite	Graphite
29	2	Wave spring	17-7 PH	1.4568	17-7 PH	1.4568
30	1	Parallel key	316SS/316Ti	1.4571, 1.4401	316SS/316Ti	1.4571, 1.4401
31	1	Hex head plug	A182 Gr.F316	1.4401	A182 Gr.F316	1.4401

Floating Ball Design High Temperature Trim Class 150-300

Floating Ball Design

Item	Quantity	Description	Carbon Steel		Stainless Steel	
			ASTM	DIN	ASTM	DIN
1	1	Body	A216 WCB	1.0619	A351 CF8M	1.4408
2	1	Tail	A216 WCB	1.0619	A351 CF8M	1.4408
3	1	Ball	A182 F316L+coating	1.4404+coating	A182 F316L+coating	1.4404+coating
4	1	Stem	A276 Gr.431	1.4057	A276 Gr.431	1.4057
5	1	Body gasket	Graphite/316Ti	Graphite/316Ti	Graphite/316Ti	Graphite/316Ti
6	2	Seat	A182 F316L +coating	1.4404+coating	A182 F316L +coating	1.4404+coating
7	1	S2 Stem seal	e-Carbon	e-Carbon	e-Carbon	e-Carbon
8	1	Packing gland	A479 316Ti, 316SS	1.4571, 1.4401	A479 316Ti, 316SS	1.4571, 1.4401
10	4	Stud	A193 Gr.B7	1.7225	A193 Gr.B8M Cl.2	A4-70
11	4	Heavy hex nut	A194 Gr.2H	1.7225	A194 Gr.8M	A4-70
13	1	Packing set	Graphite	Graphite	Graphite	Graphite
14	1	Guide bushing	A582 303 coated	1.4305 coated	A582 303 coated	1.4305 coated
21	4	Hex socket head cap screw	A193 B8M Class 2	A4-70	A193 B8M Class 2	A4-70
40	2	Seal ring	Graphite	Graphite	Graphite	Graphite
41	1	Wave spring	A286	1.4980	A286	1.4980
42	1	S-Ring	F51, A276 UNS S31803, A276 316L, A276 316Ti	1.4462, 1.4404, 1.4571	F51, A276 UNS S31803, A276 316L, A276 316Ti	1.4462, 1.4404, 1.4571

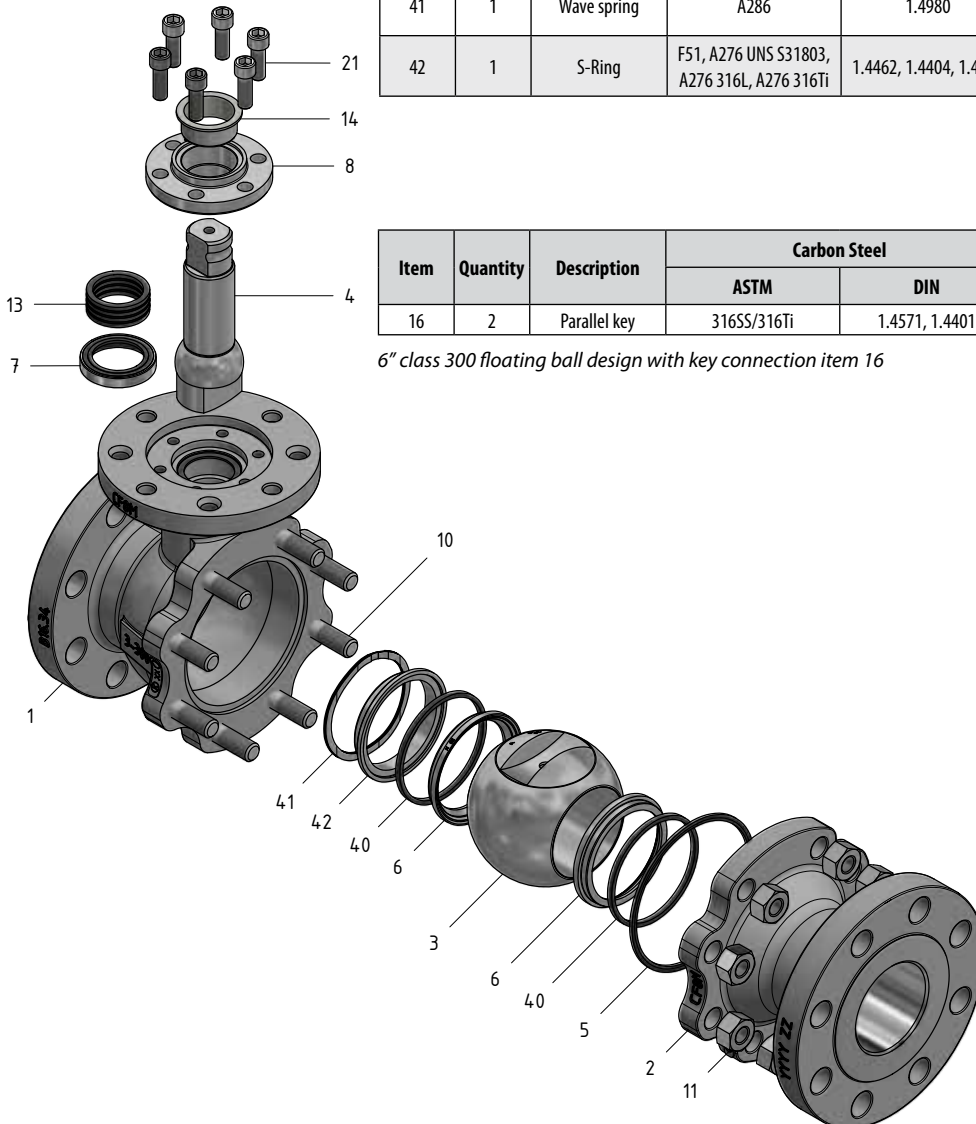

Item	Quantity	Description	Carbon Steel		Stainless Steel	
			ASTM	DIN	ASTM	DIN
16	2	Parallel key	316SS/316Ti	1.4571, 1.4401	316SS/316Ti	1.4571, 1.4401

6" class 300 floating ball design with key connection item 16

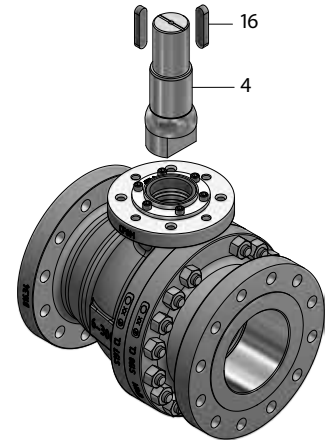

Trunnion Design High Temperature Trim Class 150-300

Trunnion Design

Item	Quantity	Description	Carbon Steel		Stainless Steel	
			ASTM	DIN	ASTM	DIN
1	1	Body	A216 WCB	1.0619	A351 CF8M	1.4408
2	1	Tail	A216 WCB	1.0619	A351 CF8M	1.4408
3	1	Ball	A182 F316L+coating	1.4404+coating	A182 F316L+coating	1.4404+coating
4	1	Stem	A276 Gr.431	1.4057	A276 Gr.431	1.4057
5	1	Body gasket	PTFE/Graphite/316Ti	PTFE/Graphite/1.4571	PTFE/Graphite/316Ti	PTFE/Graphite/1.4571
6	2	Seat	A182 F316L+ coating	1.4404+ coating	A182 F316L +coating	1.4404 +coating
7	1	Thrust washer	Inconel 625+ coating	Inconel 625+ coating	Inconel 625+ coating	Inconel 625+ coating
8	1	Gland	A582 303	1.4305	A582 303	1.4305
10	12	Stud	A193 Gr.B7	1.7225	A193 Gr.B8M Cl.2	A4-70
11	12	Heavy hex nut	A193 Gr.2H	1.7225	A194 Gr.8M	A4-70
13	1	Packing set	Graphite	Graphite	Graphite	Graphite
14	2	Sleeve bearing	Inconel 625+ coating	Inconel 625+ coating	Inconel 625+ coating	Inconel 625+ coating
15	1	Gland flange	A516 Gr.70	1.0425	A240 316Ti, 316SS	1.4571, 1.4401
16	1	Sleeve bearing	Inconel 625+coating	Inconel 625+coating	Inconel 625+coating	Inconel 625+coating
17	1	Bottom stem	A479 316Ti, 316SS	1.4571, 1.4401	A479 316Ti, 316SS	1.4571, 1.4401
18	1	Sealing	Graphite/316Ti	Graphite/316Ti	Graphite/316Ti	Graphite/316Ti
19	1	Cover	A479 316Ti, 316SS	1.4571, 1.4401	A479 316Ti, 316SS	1.4571, 1.4401
20	6	Stud	A193 Gr.B7	1.7225	A193 Gr.B8M Cl.2	A4-70
21	6	Heavy hex nut	A193 Gr.2H	1.7225	A194 Gr.8M	A4-70
22	2	Stud	A193 Gr.B7	1.7225	A193 Gr.B8M Cl.2	A4-70
23	2	Heavy hex nut	A193 Gr.2H	1.7225	A194 Gr.8M	A4-70
24	1	Retaining ring	Stainless Steel	1.4122	Stainless Steel	1.4122
25	2	Wiper ring	Graphite	Graphite	Graphite	Graphite
26	2	S-Ring	A182 F316L	1.4404	A182 F316L	1.4404
27	2	Seal ring	Graphite	Graphite	Graphite	Graphite
29	2	Wave spring	A286	1.4980	A286	1.4980
30	2	Parallel key	316SS/316Ti	1.4571, 1.4401	316SS/316Ti	1.4571, 1.4401
31	1	Hex head plug	A182 Gr.F316	1.4401	A182 Gr.F316	1.4401

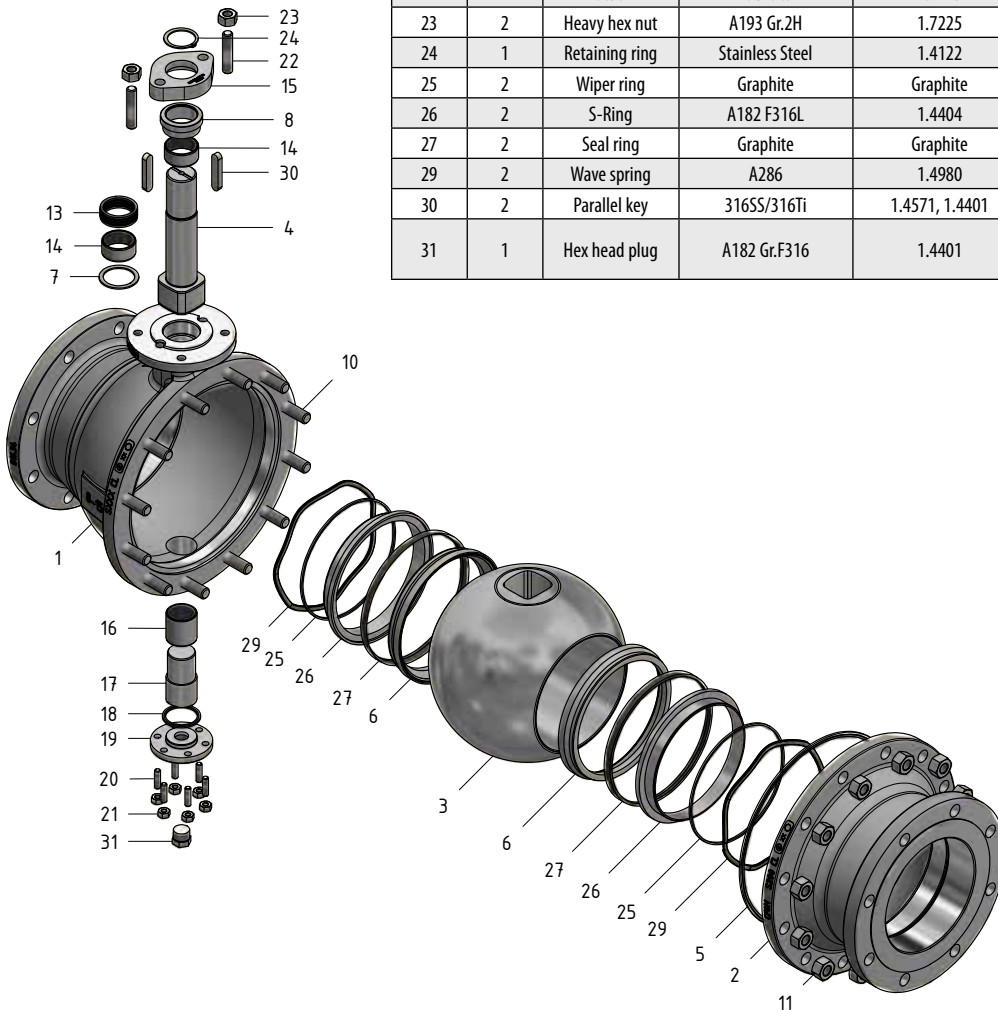

Floating Ball Design High Temperature Trim Class 600-900

Floating Ball Design

Item	Quantity	Description	Carbon Steel		Stainless Steel	
			ASTM	DIN	ASTM	DIN
1	1	Body	A216 WCB	1.0619	A351 CF8M	1.4408
2	1	Tail	A216 WCB	1.0619	A351 CF8M	1.4408
3	1	Ball	A182 F316L+coating	1.4404+coating	A182 F316L+coating	1.4404+coating
4	1	Stem	A276 Gr.431	1.4057	A276 Gr.431	1.4057
5	1	Body gasket	Graphite/316Ti	Graphite/316Ti	Graphite/316Ti	Graphite/316Ti
6	2	Seat	A182 F316L+coating	1.4404+coating	A182 F316L+coating	1.4404+coating
7	1	S2 Stem Seal	e-Carbon	e-Carbon	e-Carbon	e-Carbon
8	1	Press nut	A479 316Ti, 316SS	1.4571, 1.4401	A479 316Ti, 316SS	1.4571, 1.4401
10	4	Stud	A193 Gr.B7	1.7225	A193 Gr.B8M Cl.2	A4-70
11	4	Heavy hex nut	A194 Gr.2H	1.7225	A194 Gr.8M	A4-70
13	1	Packing	Graphite	Graphite	Graphite	Graphite
14	1	Guide bushing	A582 303 coated	1.4305 coated	A582 303 coated	1.4305 coated
15	1	Wiper ring	Graphite	Graphite	Graphite	Graphite
40	2	Seal ring	Graphite	Graphite	Graphite	Graphite
41	1	Wave spring	A286	1.4980	A286	1.4980
42	1	S-Ring	F51, A276 UNS S31803, A276 316L, A276 316Ti	1.4462, 1.4404, 1.4571	F51, A276 UNS S31803, A276 316L, A276 316Ti	1.4462, 1.4404, 1.4571

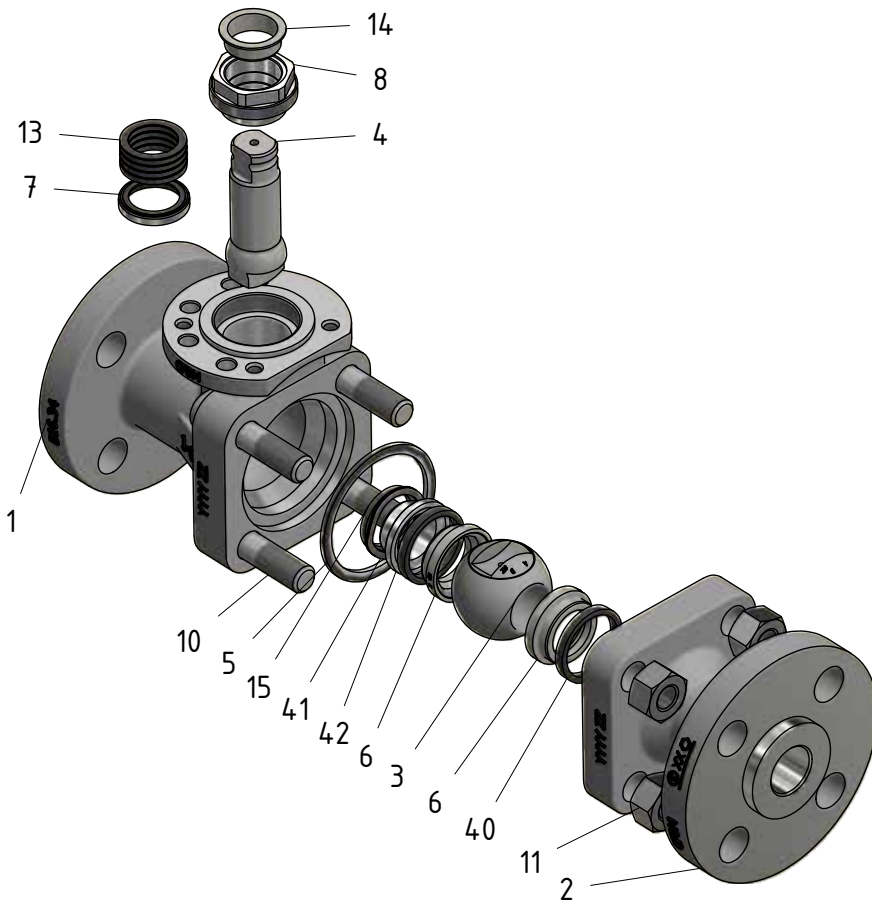

Trunnion Design High Temperature Trim Class 600-900

Trunnion Design

Item	Quantity	Description	Carbon Steel		Stainless Steel	
			ASTM	DIN	ASTM	DIN
1	1	Body	A216 WCB	1.0619	A351 CF8M	1.4408
2	1	Tail	A216 WCB	1.0619	A351 CF8M	1.4408
3	1	Ball	A351 CF8M+coating, A182 F316L+coating	1.4408+coating, 1.4404+coating	A351 CF8M+coating, A182 F316L+coating	1.4408+coating, 1.4404+coating
4	1	Stem	A276 Gr.431	1.4057	A276 Gr.431	1.4057
5	1	Body gasket	Graphite	Graphite	Graphite	Graphite
6	2	Seat	A182 F316L+coating	1.4404+coating	A182 F316L+coating	1.4404+coating
7	1	Thrust Washer	Inconel 625+coating	Inconel 625+coating	Inconel 625+coating	Inconel 625+coating
8	1	Gland	A582 Gr.303	1.4305	A582 Gr.303	1.4305
9	1	Bonnet	A216 WCB	1.0619	A351 CF8M	1.4408
10	12	Stud	A193 Gr.B7	1.7225	A193 Gr.B8M Cl.2	A4-70
11	12	Heavy hex nut	A194 Gr.2H	1.7225	A194 Gr.8M	A4-70
13	1	Packing	Graphite	Graphite	Graphite	Graphite
14	1	Sleeve bearing	Inconel 625+coating	Inconel 625+coating	Inconel 625+coating	Inconel 625+coating
15	1	Gland flange	A516 Gr.70	1.0425	A479 316Ti, 316SS	1.4571, 1.4401
16	1	Sleeve bearing	Inconel 625+coating	Inconel 625+coating	Inconel 625+coating	Inconel 625+coating
17	1	Trunnion	A479 316Ti, 316SS	1.4571, 1.4401	A479 316Ti, 316SS	1.4571, 1.4401
18	2	Body gasket	Graphite	Graphite	Graphite	Graphite
19	1	Cover	A105	1.0460	A479 316Ti; 316SS	1.4571, 1.4401
20	6	Hex sock. head cap screw	A193 Gr.B8M Cl.2	1.7225	A193 Gr.B8M Cl.2	A193 Gr.B8M Cl.2
22	3	Stud	A193 Gr.B7	1.7225	A193 Gr.B8M Cl.2	A193 Gr.B8M Cl.2
23	3	Heavy hex nut	A194 Gr.2H	1.7225	A194 Gr.8M	A4-70
24	6	Hex sock. head cap screw	A193 Gr.B8M Cl.2	1.7225	A193 Gr.B8M Cl.2	A193 Gr.B8M Cl.2
25	2	Wiper ring	Graphite	Graphite	Graphite	Graphite
26	2	S-Ring	A276 Gr.316Ti, 316L	1.4571, 1.4404	A276 Gr.316Ti, 316L	1.4571, 1.4404
27	2	Seal ring	Graphite	Graphite	Graphite	Graphite
29	2	Wave spring	A286	1.4980	A286	1.4980
30	2	Parallel key	316SS/316Ti	1.4571, 1.4401	316SS/316Ti	1.4571, 1.4401
31	1	Hex head plug	A182 Gr.F316	1.4401	A182 Gr.F316	1.4401
32	1	Sleeve bearing	Inconel 625+coating	Inconel 625+coating	Inconel 625+coating	Inconel 625+coating
33	2	Parallel pin	316SS/316Ti	1.4571, 1.4401	316SS/316Ti	1.4571, 1.4401
50	1	Name plate	SS304	1.4301	SS304	1.4301

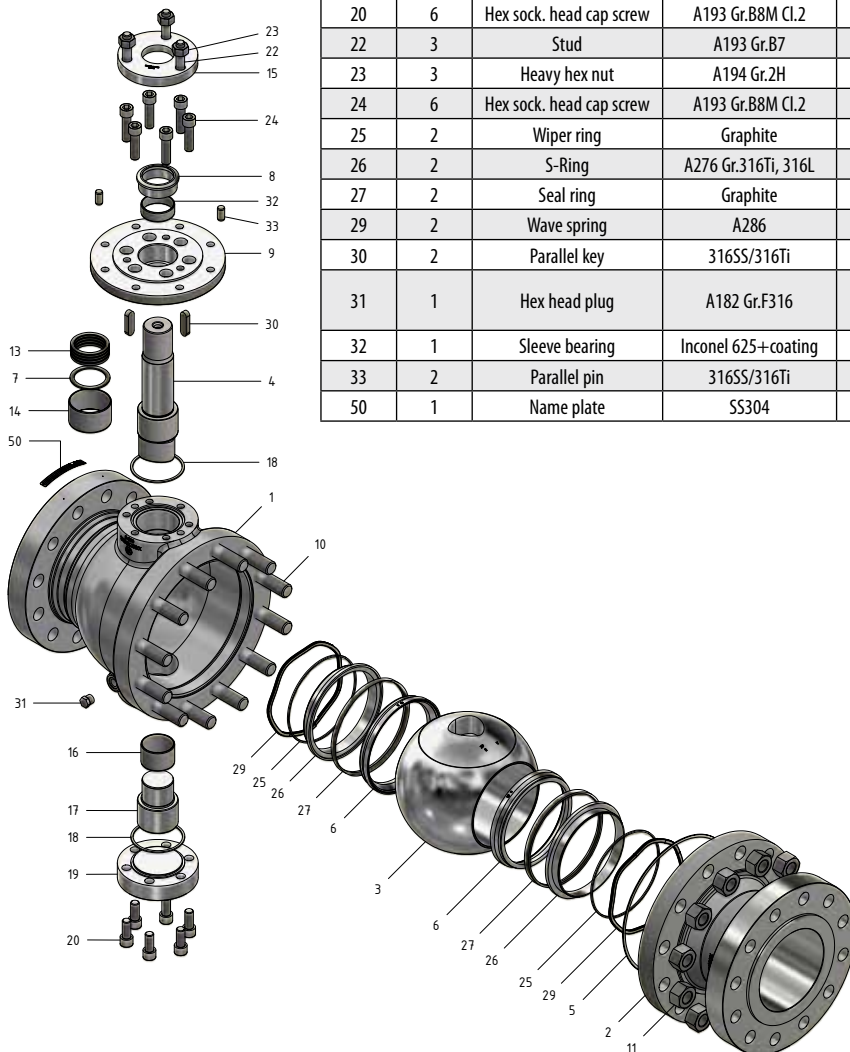

Floating Ball Design Dimensions and Weights Class 150

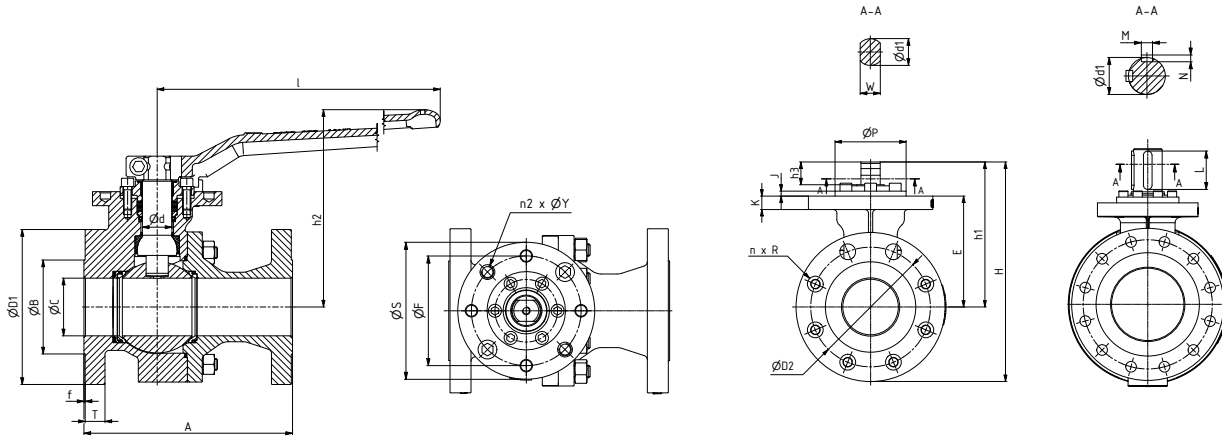

Dimensions D1, L, h2, S, E, h1 and H are for reference only.

DN	NPS	Dimensions (inch)														Weights (lb)
		A	ØC	H	h1	E	ØD1	ØD2	n	R	ØB	T	f	h2	l	
15	1/2"	4.25	0.51	5.61	2.72	1.93	3.50	2.38	4	0.62	1.38	0.38	0.06	3.86	7.17	5
20	3/4"	4.61	0.75	6.04	2.95	2.17	3.88	2.75	4	0.62	1.69	0.44	0.06	4.09	7.17	6
25	1"	5.00	0.98	6.34	3.07	2.28	4.25	3.12	4	0.62	2.00	0.50	0.06	4.21	7.17	8
40	1 1/2"	6.50	1.50	8.44	4.37	3.27	5.00	3.88	4	0.62	2.88	0.63	0.06	5.94	11.02	17
50	2"	7.00	1.93	9.22	4.65	3.54	6.00	4.75	4	0.75	3.62	0.69	0.06	6.22	13.50	23
80	3"	8.00	3.07	12.49	6.50	5.00	7.50	6.00	4	0.75	5.00	0.88	0.06	8.74	17.72	50
100	4"	9.00	3.94	15.44	8.46	6.57	9.00	7.50	8	0.75	6.19	0.88	0.06	10.94	28.35	83
150	6"	15.50	5.94	17.05	10.39	8.35	11.00	9.50	8	0.88	8.50	0.94	0.06	-	-	214

DN	NPS	Dimensions (inch)														
		ISO 5211	ØS	ØP	ØF	n2	ØY	K	J	Ød	L	M	N	h3	W	Ød1
15	1/2"	F05	2.56	1.38	1.97	4	M6	0.39	0.08	0.63	-	-	-	0.51	0.43	0.55
20	3/4"	F05	2.56	1.38	1.97	4	M6	0.43	0.08	0.63	-	-	-	0.51	0.43	0.55
25	1"	F05	2.56	1.38	1.97	4	M6	0.35	0.08	0.63	-	-	-	0.51	0.43	0.55
40	1 1/2"	F07	3.54	2.17	2.76	4	M8	0.35	0.12	0.79	-	-	-	0.79	0.55	0.71
50	2"	F07	3.54	2.17	2.76	4	M8	0.39	0.12	0.79	-	-	-	0.79	0.55	0.71
80	3"	F10	4.92	2.76	4.02	4	M10	0.85	0.12	1.10	-	-	-	1.02	0.75	0.98
100	4"	F14	6.89	3.94	5.51	4	M16	0.71	0.24	1.57	-	-	-	1.32	1.06	1.42
150	6"	F14	6.89	3.94	5.51	4	M16	0.87	0.24	1.97	-	-	-	1.57	1.42	1.89

DN	NPS	Dimensions (mm)														Weights (kg)
		A	ØC	H	h1	E	ØD1	ØD2	n	R	ØB	T	f	h2	l	
15	1/2"	108	13	143	69	49	89.0	60.5	4	15.8	35.0	9.7	1.6	98	182	2.3
20	3/4"	117	19	153	75	55	98.6	69.9	4	15.8	43.0	11.1	1.6	104	182	2.9
25	1"	127	25	161	78	58	108.0	79.2	4	15.8	50.8	12.7	1.6	107	182	3.5
40	1 1/2"	165	38	215	111	83	127.0	98.6	4	15.8	73.2	15.9	1.6	151	280	7.8
50	2"	178	49	234	118	90	152.4	120.7	4	19.0	92.0	17.5	1.6	158	343	10.6
80	3"	203	78	317	165	127	190.5	152.0	4	19.0	127.0	22.3	1.6	222	450	22.6
100	4"	229	100	392	215	167	228.6	190.5	8	19.0	157.2	22.3	1.6	278	720	37.6
150	6"	394	151	433	264	212	279.4	241.3	8	22.2	215.9	23.8	1.6	-	-	96.9

DN	NPS	Dimensions (mm)														
		ISO 5211	ØS	ØP	ØF	n2	ØY	K	J	Ød	L	M	N	h3	W	Ød1
15	1/2"	F05	65	35	50	4	M6	10.0	2	16	-	-	-	13.0	11	14
20	3/4"	F05	65	35	50	4	M6	11.0	2	16	-	-	-	13.0	11	14
25	1"	F05	65	35	50	4	M6	9.0	2	16	-	-	-	13.0	11	14
40	1 1/2"	F07	90	55	70	4	M8	9.0	3	20	-	-	-	20.0	14	18
50	2"	F07	90	55	70	4	M8	10.0	3	20	-	-	-	20.0	14	18
80	3"	F10	125	70	102	4	M10	21.5	3	28	-	-	-	26.0	19	25
100	4"	F14	175	100	140	4	M16	18.0	6	40	-	-	-	33.5	27	36
150	6"	F14	175	100	140	4	M16	22.0	6	50	-	-	-	40.0	36	48

Floating Ball Design Dimensions and Weights Class 300

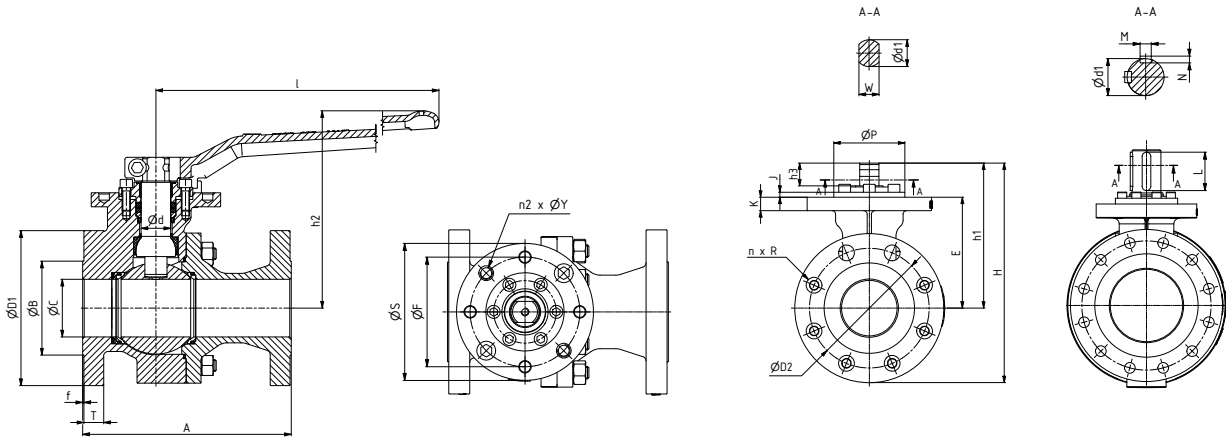

Dimensions D1, L, h2, S, E, h1 and H are for reference only.

DN	NPS	Dimensions (inch)														Weights (lb)
		A	ØC	H	h1	E	ØD1	ØD2	n	R	ØB	T	f	h2	l	
15	1/2"	5.50	0.51	5.73	2.72	1.93	3.75	2.62	4	0.62	1.38	0.50	0.06	3.86	7.17	7
20	3/4"	6.00	0.75	6.40	2.95	2.17	4.62	3.25	4	0.75	1.69	0.56	0.06	4.09	7.17	10
25	1"	6.50	0.98	6.65	3.07	2.28	4.88	3.50	4	0.75	2.00	0.62	0.06	4.21	7.17	11
40	1 1/2"	7.50	1.50	9.00	4.37	3.27	6.12	4.50	4	0.87	2.88	0.75	0.06	5.94	13.50	24
50	2"	8.50	1.93	11.32	5.79	4.29	6.50	5.00	8	0.75	3.62	0.81	0.06	8.07	17.72	35
80	3"	11.13	3.07	14.56	8.03	6.14	8.25	6.62	8	0.87	5.00	1.06	0.06	10.43	28.35	76
100	4"	12.00	3.94	13.78	8.78	6.73	10.00	7.88	8	0.87	6.19	1.19	0.06	-	-	124
150	6"	15.88	5.94	19.53	12.80	8.35	12.50	10.62	12	0.88	8.50	1.38	0.06	-	-	301

DN	NPS	Dimensions (inch)														
		ISO 5211	ØS	ØP	ØF	n2	ØY	K	J	Ød	L	M	N	h3	W	Ød1
15	1/2"	F05	2.56	1.38	1.97	4	M6	0.39	0.08	0.63	-	-	-	0.51	0.43	0.55
20	3/4"	F05	2.56	1.38	1.97	4	M6	0.43	0.08	0.63	-	-	-	0.51	0.43	0.55
25	1"	F05	2.56	1.38	1.97	4	M6	0.35	0.08	0.63	-	-	-	0.51	0.43	0.55
40	1 1/2"	F07	3.54	2.17	2.76	4	M8	0.35	0.12	0.79	-	-	-	0.79	0.55	0.71
50	2"	F10	4.92	2.76	4.02	4	M10	0.67	0.12	1.10	-	-	-	1.02	0.75	0.98
80	3"	F14	6.89	3.94	5.51	4	M16	0.75	0.24	1.57	-	-	-	1.32	1.06	1.42
100	4"	F14	6.89	3.94	5.51	4	M16	0.94	0.24	1.97	-	-	-	1.57	1.42	1.89
150	6"	F16	8.27	5.12	6.50	4	M20	1.14	0.28	2.76	3.15	0.71	0.43	-	-	-

DN	NPS	Dimensions (mm)														Weights (kg)
		A	ØC	H	h1	E	ØD1	ØD2	n	R	ØB	T	f	h2	l	
15	1/2"	140	13	146	69	49	95.2	66.5	4	15.8	35.0	12.7	1.6	98	182	3.2
20	3/4"	152	19	163	75	55	117.3	82.6	4	19.0	43.0	14.1	1.6	104	182	4.5
25	1"	165	25	169	78	58	124.0	88.9	4	19.0	50.8	15.8	1.6	107	182	5.1
40	1 1/2"	190	38	229	111	83	155.4	114.3	4	22.2	73.2	19.1	1.6	151	343	11.0
50	2"	216	49	288	147	109	165.0	127.0	8	19.0	92.0	20.7	1.6	205	450	15.9
80	3"	282	78	370	204	156	209.6	168.2	8	22.2	127.0	26.8	1.6	265	720	34.5
100	4"	305	100	350	223	171	254.0	200.2	8	22.2	157.2	30.2	1.6	-	-	56.3
150	6"	403	151	496	325	212	317.5	269.7	12	22.2	215.9	35.0	1.6	-	-	136.6

DN	NPS	Dimensions (mm)														
		ISO 5211	ØS	ØP	ØF	n2	ØY	K	J	Ød	L	M	N	h3	W	Ød1
15	1/2"	F05	65	35	50	4	M6	10	2	16	-	-	-	13.0	11	14
20	3/4"	F05	65	35	50	4	M6	11	2	16	-	-	-	13.0	11	14
25	1"	F05	65	35	50	4	M6	9	2	16	-	-	-	13.0	11	14
40	1 1/2"	F07	90	55	70	4	M8	9	3	20	-	-	-	20.0	14	18
50	2"	F10	125	70	102	4	M10	17	3	28	-	-	-	26.0	19	25
80	3"	F14	175	100	140	4	M16	19	6	40	-	-	-	33.5	27	36
100	4"	F14	175	100	140	4	M16	24	6	50	-	-	-	40.0	36	48
150	6"	F16	210	130	165	4	M20	29	7	70	80	18	11	-	-	-

Floating Ball Design Dimensions and Weights Class 600

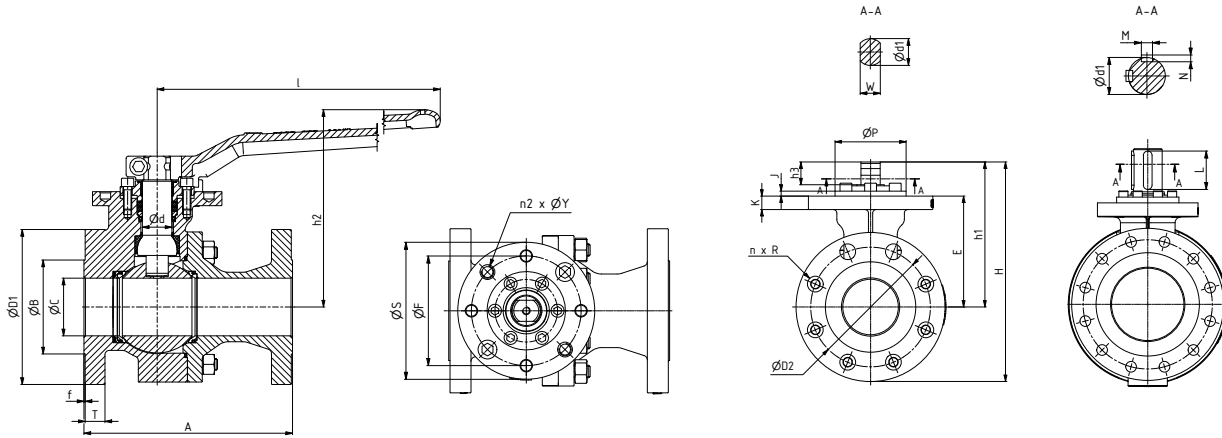

Dimensions D1, L, h2, S, E, h1 and H are for reference only.

DN	NPS	Dimensions (inch)														Weights (lb)
		A	ØC	H	h1	E	ØD1	ØD2	n	R	ØB	T	f	h2	I	
15	1/2"	6.50	0.51	4.59	2.72	1.95	3.75	2.62	4	0.63	1.37	0.56	0.25	3.86	7.17	10
20	3/4"	7.50	0.75	5.67	3.41	2.52	4.62	3.25	4	0.75	1.69	0.62	0.25	5.75	11.02	17
25	1"	8.50	0.98	6.18	3.72	2.64	4.88	3.50	4	0.75	2.00	0.69	0.25	6.06	13.50	20
40	1 1/2"	9.50	1.50	8.33	5.28	3.78	6.12	4.50	4	0.87	2.87	0.88	0.25	7.56	17.72	42

DN	NPS	Dimensions (inch)														
		ISO 5211	ØS	ØP	ØF	n2	ØY	K	J	Ød	L	M	N	h3	W	Ø d1
15	1/2"	F05	2.56	1.38	1.97	4	M6	0.57	0.08	0.63	-	-	-	0.47	0.43	0.55
20	3/4"	F05	2.56	1.38	1.97	4	M6	0.83	0.12	0.79	-	-	-	0.55	0.55	0.71
25	1"	F07	3.54	2.17	2.76	4	M8	0.39	0.12	0.94	-	-	-	0.63	0.67	0.87
40	1 1/2"	F10	4.92	2.76	4.02	4	M10	0.67	0.12	1.10	-	-	-	0.98	0.75	0.98

DN	NPS	Dimensions (mm)														Weights (kg)
		A	ØC	H	h1	E	ØD1	ØD2	n	R	ØB	T	f	h2	I	
15	1/2"	165	13	117	69.0	49.5	95	66.7	4	16	34.9	15.0	7	98	182	4.7
20	3/4"	190	19	144	86.5	64.0	115	82.6	4	19	42.9	16.5	7	146	280	7.6
25	1"	216	25	157	94.5	67.0	125	88.9	4	19	50.8	17.5	7	154	343	8.9
40	1 1/2"	241	38	212	134.0	96.0	155	114.3	4	22	73.0	23.5	7	192	450	19.0

DN	NPS	Dimensions (mm)														
		ISO 5211	ØS	ØP	ØF	n2	ØY	K	J	Ød	L	M	N	h3	W	Ø d1
15	1/2"	F05	65	35	50	4	M6	14.5	2	16	-	-	-	12	11	14
20	3/4"	F05	65	35	50	4	M6	21.0	3	20	-	-	-	14	14	18
25	1"	F07	90	55	70	4	M8	10.0	3	24	-	-	-	16	17	22
40	1 1/2"	F10	125	70	102	4	M10	17.0	3	28	-	-	-	25	19	25

Floating Ball Design Dimensions and Weights Class 900

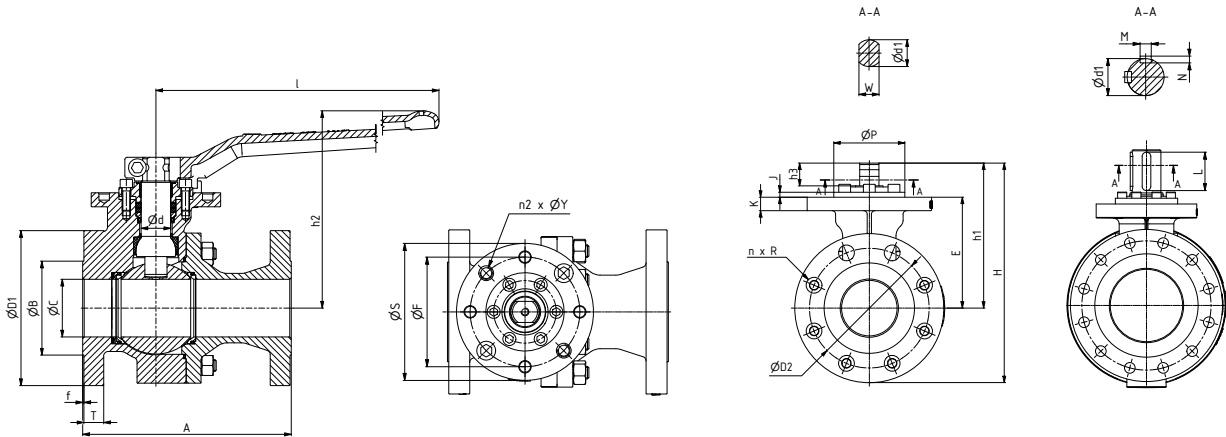

Dimensions D1, L, h2, S, E, h1 and H are for reference only.

DN	NPS	Dimensions (inch)														Weights (lb)
		A	ØC	H	h1	E	ØD1	ØD2	n	R	ØB	T	f	h2	l	
15	1/2"	8.50	0.51	5.61	3.25	2.44	4.75	3.25	4	0.87	1.37	0.88	0.25	5.67	11.02	19
20	3/4"	9.00	0.75	5.96	3.41	2.52	5.12	3.50	4	0.87	1.69	1.00	0.25	5.75	11.02	25
25	1"	10.00	0.98	6.67	3.72	2.64	5.88	4.00	4	1.00	2.00	1.12	0.25	6.06	13.50	32
40	1 1/2"	12.00	1.50	8.82	5.28	3.78	7.00	4.88	4	1.12	2.87	1.25	0.25	7.56	17.72	60

DN	NPS	Dimensions (inch)														
		ISO 5211	ØS	ØP	ØF	n2	ØY	K	J	Ød	L	M	N	h3	W	Ød1
15	1/2"	F05	2.56	1.38	1.97	4	M6	0.94	0.12	0.79	-	-	-	0.47	0.55	0.71
20	3/4"	F05	2.56	1.38	1.97	4	M6	0.75	0.12	0.79	-	-	-	0.55	0.55	0.71
25	1"	F07	3.54	2.17	2.76	4	M8	0.39	0.12	0.94	-	-	-	0.63	0.67	0.87
40	1 1/2"	F10	4.92	2.76	4.02	4	M10	0.67	0.12	1.1	-	-	-	0.98	0.75	0.98

DN	NPS	Dimensions (mm)														Weights (kg)
		A	ØC	H	h1	E	ØD1	ØD2	n	R	ØB	T	f	h2	l	
15	1/2"	216	13	143	82.5	62	120	82.6	4	22.0	34.9	23.0	7	144	280	8.4
20	3/4"	229	19	152	86.5	64	130	88.9	4	22.0	42.9	26.0	7	146	280	11.4
25	1"	254	25	170	94.5	67	150	101.6	4	25.4	50.8	29.0	7	154	343	14.5
40	1 1/2"	305	38	224	134.0	96	180	123.8	4	28.5	73.0	33.5	7	192	450	27.1

DN	NPS	Dimensions (mm)														
		ISO 5211	ØS	ØP	ØF	n2	ØY	K	J	Ød	L	M	N	h3	W	Ød1
15	1/2"	F05	65	35	50	4	M6	24	3	20	-	-	-	12	14	18
20	3/4"	F05	65	35	50	4	M6	19	3	20	-	-	-	14	14	18
25	1"	F07	90	55	70	4	M8	10	3	24	-	-	-	16	17	22
40	1 1/2"	F10	125	70	102	4	M10	17	3	28	-	-	-	25	19	25

Trunnion Design

Dimensions and Weights Class 150

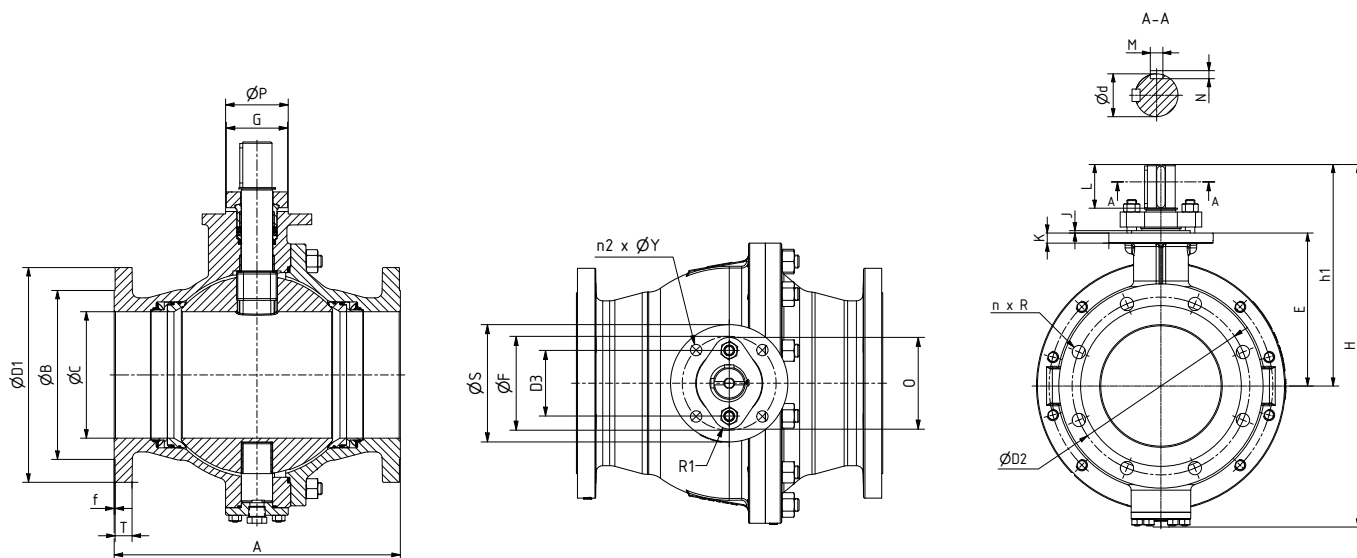

Dimensions D1, L, S, E, h1 and H are for reference only.

DN	NPS	Dimensions (inch)															Weights (lb)	
		A	ØC	H	h1	E	ØD1	ØD2	n	R	ØB	T	f	O	G	D3		R1
200	8"	18.00	7.95	23.46	14.57	10.12	13.50	11.75	8	0.88	10.62	1.06	0.06	5.08	3.82	3.86	0.79	377
250	10"	21.00	9.92	26.65	16.26	11.81	16.00	14.25	12	1.00	12.75	1.12	0.06	5.08	3.82	3.86	0.79	620
300	12"	24.00	11.93	31.85	19.04	13.19	19.00	17.00	12	1.00	15.00	1.19	0.06	7.01	4.02	5.12	0.94	1017

DN	NPS	Dimensions (inch)											
		ISO 5211	ØS	ØP	ØF	n2	ØY	K	J	Ød	L	M	N
200	8"	F14	6.89	3.94	5.51	4	0.67	0.67	0.16	1.89	2.76	0.55	0.35
250	10"	F14	6.89	3.94	5.51	4	0.67	0.87	0.16	1.89	2.76	0.55	0.35
300	12"	F16	8.27	5.12	6.50	4	0.83	0.83	0.20	2.36	3.94	0.71	0.43

DN	NPS	Dimensions (mm)															Weights (kg)	
		A	ØC	H	h1	E	ØD1	ØD2	n	R	ØB	T	f	O	G	D3		R1
200	8"	457	202	596	370	257	343.0	298.4	8	22.2	269.8	26.9	1.6	129	97	98	20	171.2
250	10"	533	252	677	413	300	406.4	362.0	12	25.4	323.8	28.6	1.6	129	97	98	20	281.1
300	12"	610	303	809	483.5	335	482.6	431.8	12	25.4	381.0	30.2	1.6	178	102	130	24	461.1

DN	NPS	Dimensions (mm)											
		ISO 5211	ØS	ØP	ØF	n2	ØY	K	J	Ød	L	M	N
200	8"	F14	175	100	140	4	Ø17	17	4	48	70	14	9
250	10"	F14	175	100	140	4	Ø17	22	4	48	70	14	9
300	12"	F16	210	130	165	4	Ø21	21	5	60	100	18	11

Trunnion Design Dimensions and Weights Class 300

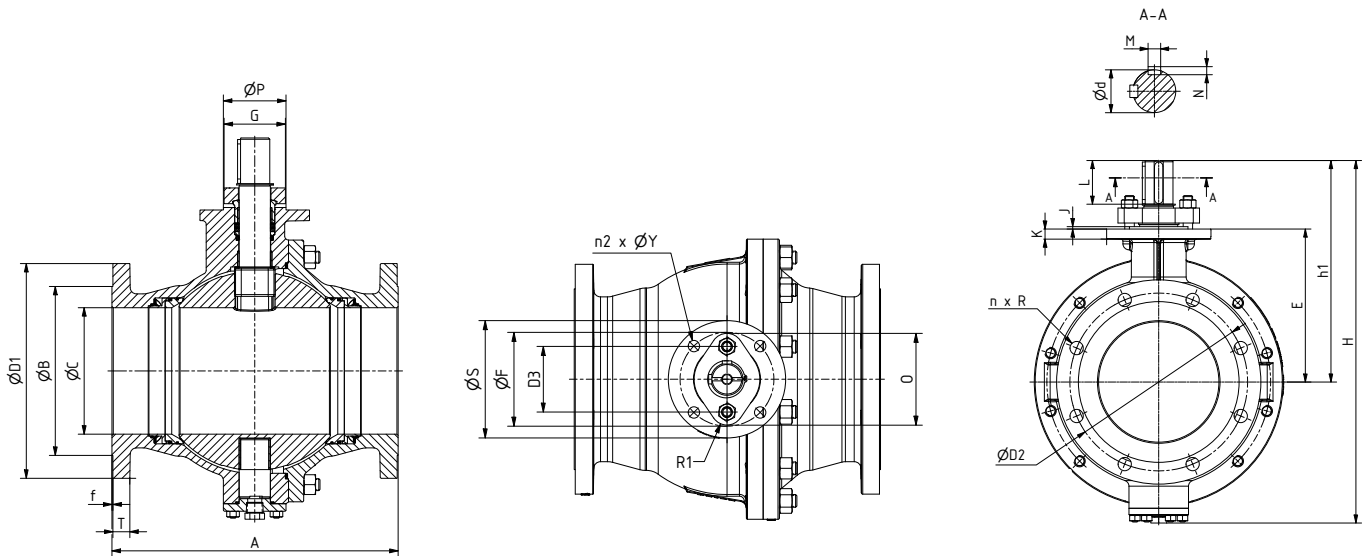

Dimensions D1, L, S, E, h1 and H are for reference only.

DN	NPS	Dimensions (inch)																Weights (lb)
		A	ØC	H	h1	E	ØD1	ØD2	n	R	ØB	T	f	O	G	D3	R1	
200	8"	19.75	7.95	23.98	14.72	10.08	15.00	13.00	12	1.00	10.62	1.56	0.06	7.17	5.04	5.12	0.94	517
250	10"	22.38	9.92	28.19	17.44	11.42	17.50	15.25	16	1.13	12.75	1.81	0.06	7.17	5.04	5.12	0.94	914
300	12"	25.50	11.93	32.44	19.59	13.19	20.50	17.75	16	1.25	15.00	1.94	0.06	7.80	6.30	5.75	0.94	1312

DN	NPS	Dimensions (inch)											
		ISO 5211	ØS	ØP	ØF	n2	ØY	K	J	Ød	L	M	N
200	8"	F16	8.27	5.12	6.5	4	0.83	0.83	0.20	2.36	2.76	0.71	0.43
250	10"	F25	11.81	7.87	10	8	0.67	0.71	0.20	2.36	3.94	0.71	0.43
300	12"	F25	11.81	7.87	10	8	0.67	1.18	0.20	2.83	4.33	0.79	0.47

DN	NPS	Dimensions (mm)																Weights (kg)
		A	ØC	H	h1	E	ØD1	ØD2	n	R	ØB	T	f	O	G	D3	R1	
200	8"	502	202	609	374.0	256	381.0	330.2	12	25.4	269.8	39.5	1.6	182	128	130	24	234.6
250	10"	568	252	716	443.0	290	445.0	387.4	16	28.6	323.8	46.1	1.6	182	128	130	24	414.5
300	12"	648	303	824	497.5	335	520.7	450.8	16	31.8	381.0	49.2	1.6	198	160	146	24	595.3

DN	NPS	Dimensions (mm)											
		ISO 5211	ØS	ØP	ØF	n2	ØY	K	J	Ød	L	M	N
200	8"	F16	210	130	165	4	Ø21	21	5	60	70	18	11
250	10"	F25	300	200	254	8	Ø17	18	5	60	100	18	11
300	12"	F25	300	200	254	8	Ø17	30	5	72	110	20	12

Trunnion Design Dimensions and Weights Class 600

Dimensions D1, L, S, E, h1 and H are for reference only.

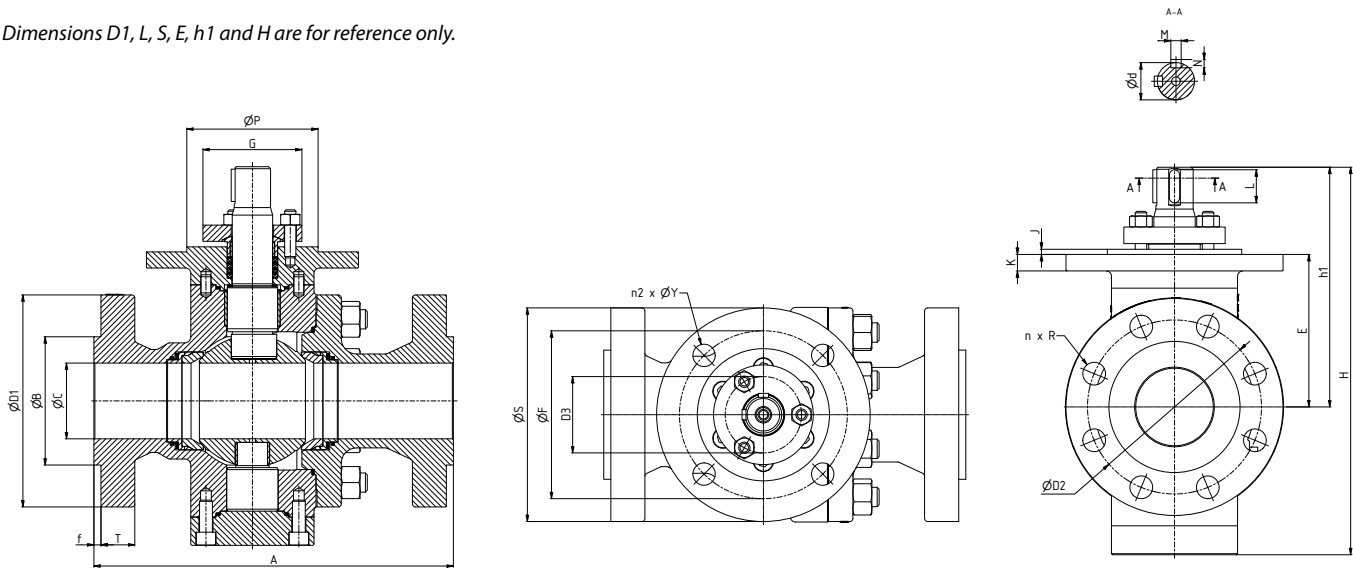

DN	NPS	Dimensions (inch)														Weights (lb)
		A	ØC	H	h1	E	ØD1	ØD2	n	R	ØB	T	f	h2	I	
50	2"	11.50	1.93	13.03	9.02	4.76	6.50	5.00	8	0.75	3.63	1.00	0.25	3.31	2.56	65
80	3"	14.00	2.95	16.73	11.10	5.81	8.25	6.62	8	0.87	5.00	1.25	0.25	3.86	2.95	139
100	4"	17.00	3.94	17.99	11.77	6.40	10.75	8.50	8	1.00	6.19	1.50	0.25	3.86	2.95	208
150	6"	22.00	5.94	23.76	15.71	9.47	14.00	11.50	12	1.14	8.50	1.88	0.25	5.51	4.33	489
200	8"	26.00	7.95	28.54	17.95	11.42	16.50	13.75	12	1.26	10.63	2.19	0.25	7.01	5.59	838
250	10"	31.00	9.92	37.32	24.69	13.58	20.00	17.00	16	1.38	12.75	2.50	0.25	7.01	5.59	1371
300	12"	33.00	11.93	40.67	26.93	15.43	22.00	19.25	20	1.38	15.00	2.62	0.25	7.52	6.10	1866

DN	NPS	Dimensions (inch)											
		ISO 5211	ØS	ØP	ØF	n2	ØY	K	J	Ød	L	M	N
50	2"	F12	5.91	3.35	4.92	4	0.53	0.63	0.12	1.10	0.98	0.31	0.28
80	3"	F16	8.27	5.12	6.50	4	0.87	0.63	0.20	1.42	1.26	0.39	0.31
100	4"	F16	8.27	5.12	6.50	4	0.87	0.63	0.20	1.50	1.26	0.39	0.31
150	6"	F25	11.81	7.87	10.00	8	0.69	0.98	0.20	2.17	2.20	0.63	0.39
200	8"	F25	11.81	7.87	10.00	8	0.69	0.98	0.20	2.56	2.48	0.71	0.43
250	10"	F30	13.39	9.06	11.73	8	0.87	1.18	0.20	2.83	3.15	0.79	0.47
300	12"	F30	13.39	9.06	11.73	8	0.87	1.18	0.20	3.35	3.54	0.87	0.55

DN	NPS	Dimensions (mm)														Weights (kg)
		A	ØC	H	h1	E	ØD1	ØD2	n	R	ØB	T	f	h2	I	
50	2"	292	49	331	229	121.0	165	127.0	8	19.0	92.1	26.5	7	84	65	29.5
80	3"	356	75	425	282	147.6	210	168.3	8	22.0	127.0	33.5	7	98	75	63.1
100	4"	432	100	457	299	162.6	275	215.9	8	25.4	157.2	40.0	7	98	75	94.5
150	6"	559	151	604	399	240.6	355	292.1	12	29.0	215.9	47.7	7	140	110	221.9
200	8"	660	202	725	456	290.0	420	349.2	12	32.0	269.9	55.6	7	178	142	380.0
250	10"	787	252	948	627	345.0	510	431.8	16	35.0	323.8	63.5	7	178	142	621.7
300	12"	838	303	1033	684	392.0	560	489.0	20	35.0	381.0	66.7	7	191	155	846.6

DN	NPS	Dimensions (mm)											
		ISO 5211	ØS	ØP	ØF	n2	ØY	K	J	Ød	L	M	N
50	2"	F12	150	85	125	4	13.5	16	3	28	25	8	7
80	3"	F16	210	130	165	4	22.0	16	5	36	32	10	8
100	4"	F16	210	130	165	4	22.0	16	5	38	32	10	8
150	6"	F25	300	200	254	8	17.5	25	5	55	56	16	10
200	8"	F25	300	200	254	8	17.5	25	5	65	63	18	11
250	10"	F30	340	230	298	8	22.0	30	5	72	80	20	12
300	12"	F30	340	230	298	8	22.0	30	5	85	90	22	14

Trunnion Design Dimensions and Weights Class 900

Dimensions D1, L, S, E, h1 and H are for reference only.

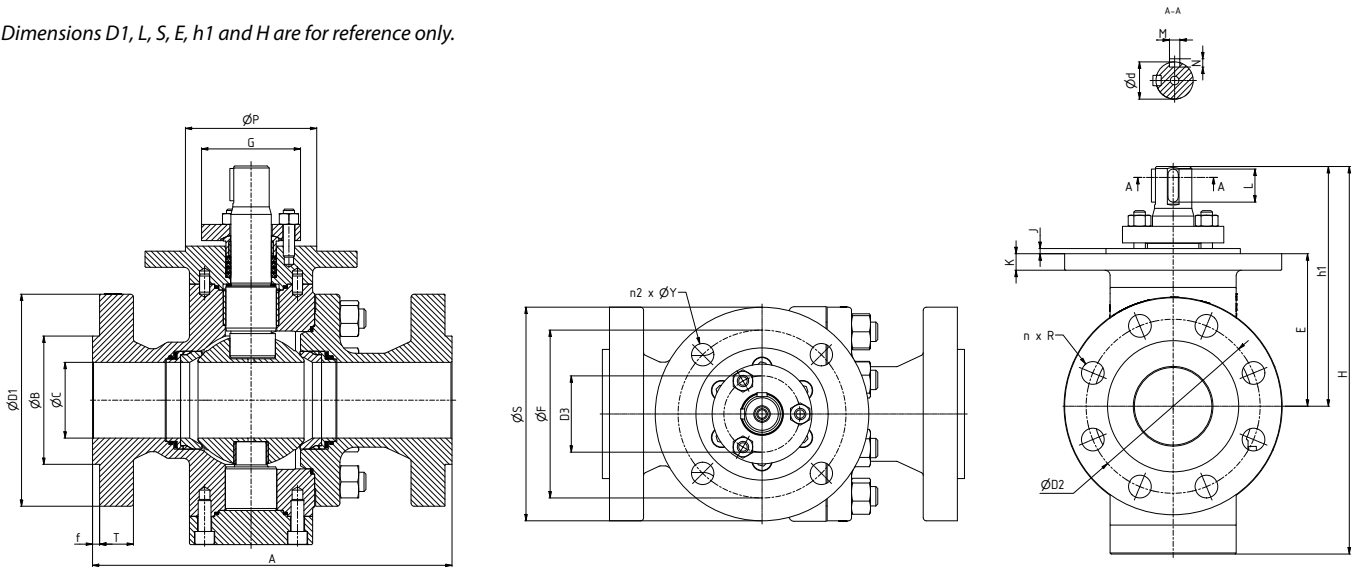

DN	NPS	Dimensions (inch)														Weights (lb)
		A	ØC	H	h1	E	ØD1	ØD2	n	R	ØB	T	f	h2	l	
50	2"	14.50	1.93	13.03	9.02	4.76	8.50	6.50	8	0.98	3.63	1.50	0.25	3.31	2.56	99
80	3"	15.00	2.95	16.73	11.10	5.81	9.50	7.50	8	1.00	5.00	1.50	0.25	3.86	2.95	171
100	4"	18.00	3.94	19.45	12.87	7.24	11.50	9.25	8	1.25	6.19	1.75	0.25	4.33	3.35	298
150	6"	24.00	5.94	24.57	15.71	9.47	15.00	12.50	12	1.25	8.50	2.19	0.25	5.51	4.33	606
200	8"	29.00	7.95	34.25	23.15	12.05	18.50	15.50	12	1.50	10.63	2.50	0.25	7.01	5.59	1111
250	10"	33.00	9.92	38.46	25.47	13.98	21.50	18.50	16	1.50	12.75	2.75	0.25	7.52	6.10	1769
300	12"	38.00	11.93	43.62	28.86	16.57	24.00	21.00	20	1.50	15.00	3.12	0.25	8.46	6.89	2618

DN	NPS	Dimensions (inch)											
		ISO 5211	ØS	ØP	ØF	n2	ØY	K	J	Ød	L	M	N
50	2"	F12	5.91	3.35	4.92	4	0.53	0.63	0.12	1.10	0.98	0.31	0.28
80	3"	F16	8.27	5.12	6.50	4	0.87	0.63	0.20	1.42	1.26	0.39	0.31
100	4"	F25	11.81	7.87	10.00	8	0.69	0.98	0.20	1.65	1.57	0.47	0.31
150	6"	F25	11.81	7.87	10.00	8	0.69	0.98	0.20	2.17	2.20	0.63	0.39
200	8"	F30	13.39	9.06	11.73	8	0.87	1.18	0.20	2.83	3.15	0.79	0.47
250	10"	F30	13.39	9.06	11.73	8	0.87	1.18	0.20	3.35	3.54	0.87	0.55
300	12"	F35	15.94	10.24	14.02	8	1.30	1.38	0.20	3.86	4.33	1.10	0.63

DN	NPS	Dimensions (mm)														Weights (kg)
		A	ØC	H	h1	E	ØD1	ØD2	n	R	ØB	T	f	h2	l	
50	2"	368	49	331	229	121.0	215	165	8	25.0	92.1	40.0	7	84	65	44.7
80	3"	381	75	425	282	147.6	240	190.5	8	25.4	127.0	39.5	7	98	75	77.4
100	4"	457	100	494	327	184.0	290	235	8	31.8	157.2	46.0	7	110	85	135.1
150	6"	610	151	624	399	240.6	380	317.5	12	31.8	215.9	55.6	7	140	110	275
200	8"	737	202	870	588	306.0	470	393.7	12	38.0	269.9	63.5	7	178	142	503.9
250	10"	838	252	977	647	355.0	545	469.9	16	38.0	323.8	69.9	7	191	155	802.2
300	12"	965	303	1108	733	421.0	610	533.4	20	38.0	381.0	79.4	7	215	175	1187.3

DN	NPS	Dimensions (mm)											
		ISO 5211	ØS	ØP	ØF	n2	ØY	K	J	Ød	L	M	N
50	2"	F12	150	85	125	4	13.5	16	3	28	25	8	7
80	3"	F16	210	130	165	4	22.0	16	5	36	32	10	8
100	4"	F25	300	200	254	8	17.5	25	5	42	40	12	8
150	6"	F25	300	200	254	8	17.5	25	5	55	56	16	10
200	8"	F30	340	230	298	8	22.0	30	5	72	80	20	12
250	10"	F30	340	230	298	8	22.0	30	5	85	90	22	14
300	12"	F35	405	260	356	8	33.0	35	5	98	110	28	16

Standard Design with Gears Class 150

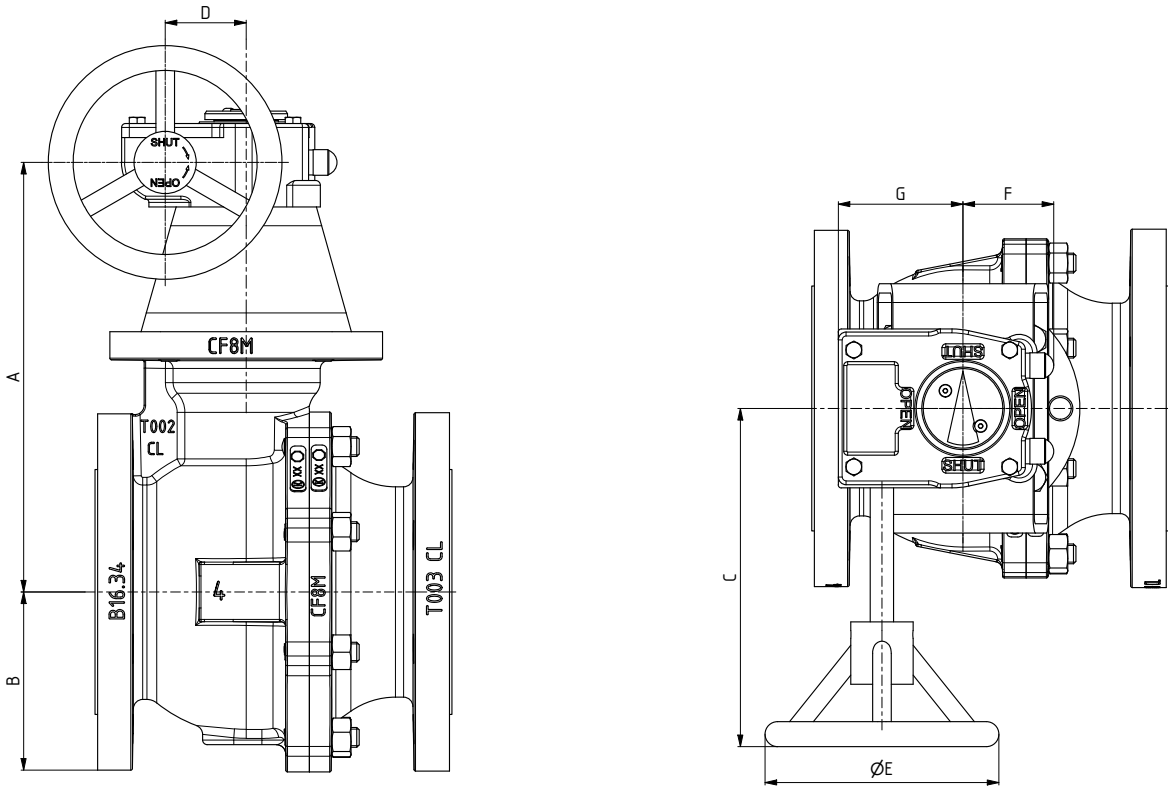

Gear dimensions are for reference only.

DN	NPS	Dimensions (inch)						
		A	B	C	D	ØE	F	G
100	4"	10.87	6.97	8.15	2.05	5.91	1.89	3.15
150	6"	13.15	6.65	10.71	3.39	11.81	3.94	4.96
200	8"	18.03	8.90	10.98	2.80	9.84	2.72	4.13
250	10"	19.76	10.39	10.71	3.39	11.81	3.94	4.96
300	12"	22.95	12.83	12.52	4.13	13.78	4.33	5.83

DN	NPS	Dimensions (mm)						
		A	B	C	D	ØE	F	G
100	4"	276	177	207	52	150	48	80
150	6"	334	169	272	86	300	100	126
200	8"	458	226	279	71	250	69	105
250	10"	502	264	272	86	300	100	126
300	12"	583	326	318	105	350	110	148

Gear size is based on clear, clean liquid fluid at maximum differential pressure.

Standard Design with Gears Class 300

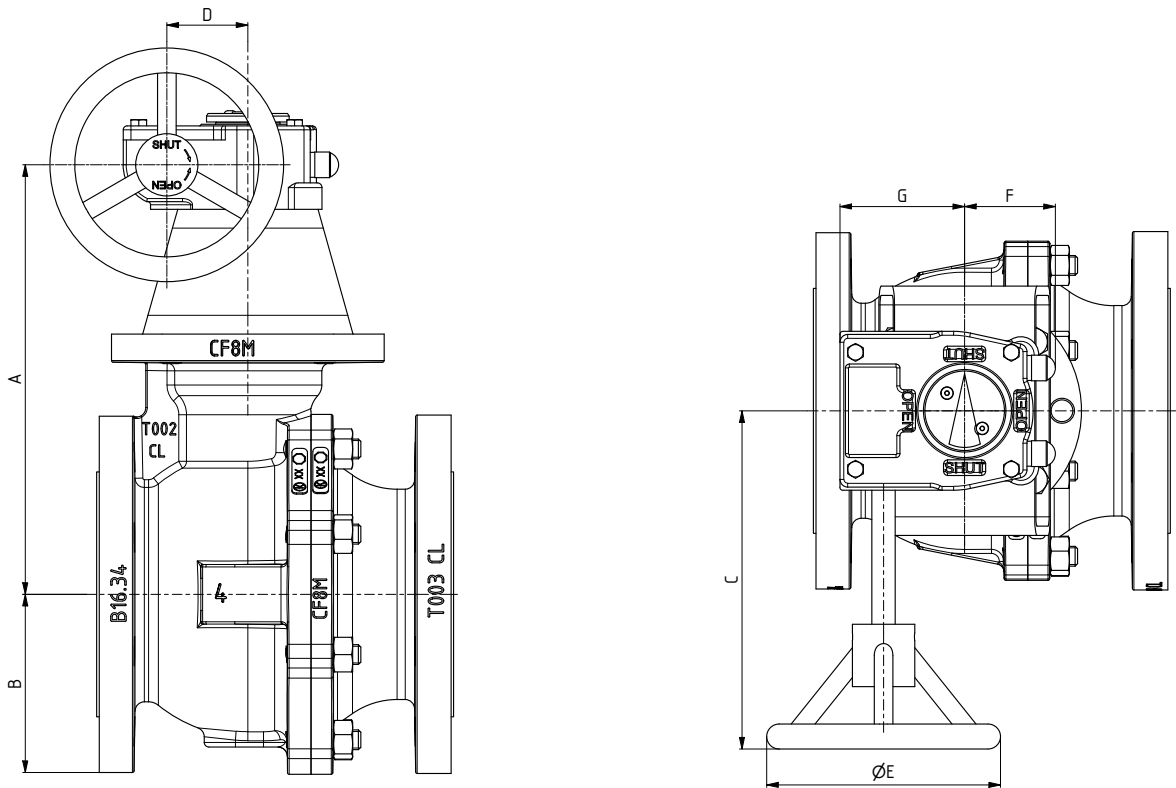

Gear dimensions are for reference only.

DN	NPS	Dimensions (inch)						
		A	B	C	D	ØE	F	G
80	3"	10.43	6.54	8.15	2.05	5.91	1.89	3.15
100	4"	11.50	5.00	10.98	2.80	9.84	2.72	4.13
150	6"	16.14	6.73	13.62	4.13	19.69	4.33	5.83
200	8"	17.87	9.25	12.32	4.13	11.81	4.33	5.83
250	10"	21.18	10.75	13.70	4.13	17.72	4.33	5.83
300	12"	23.23	12.87	14.92	4.17	9.84	5.63	7.09

DN	NPS	Dimensions (mm)						
		A	B	C	D	ØE	F	G
80	3"	265	166	207	52	150	48	80
100	4"	292	127	279	71	250	69	105
150	6"	410	171	346	105	500	110	148
200	8"	454	235	313	105	300	110	148
250	10"	538	273	348	105	450	110	148
300	12"	590	327	379	106	250	143	180

Gear size is based on clear, clean liquid fluid at maximum differential pressure.

High Temperature Design with Gears Class 150

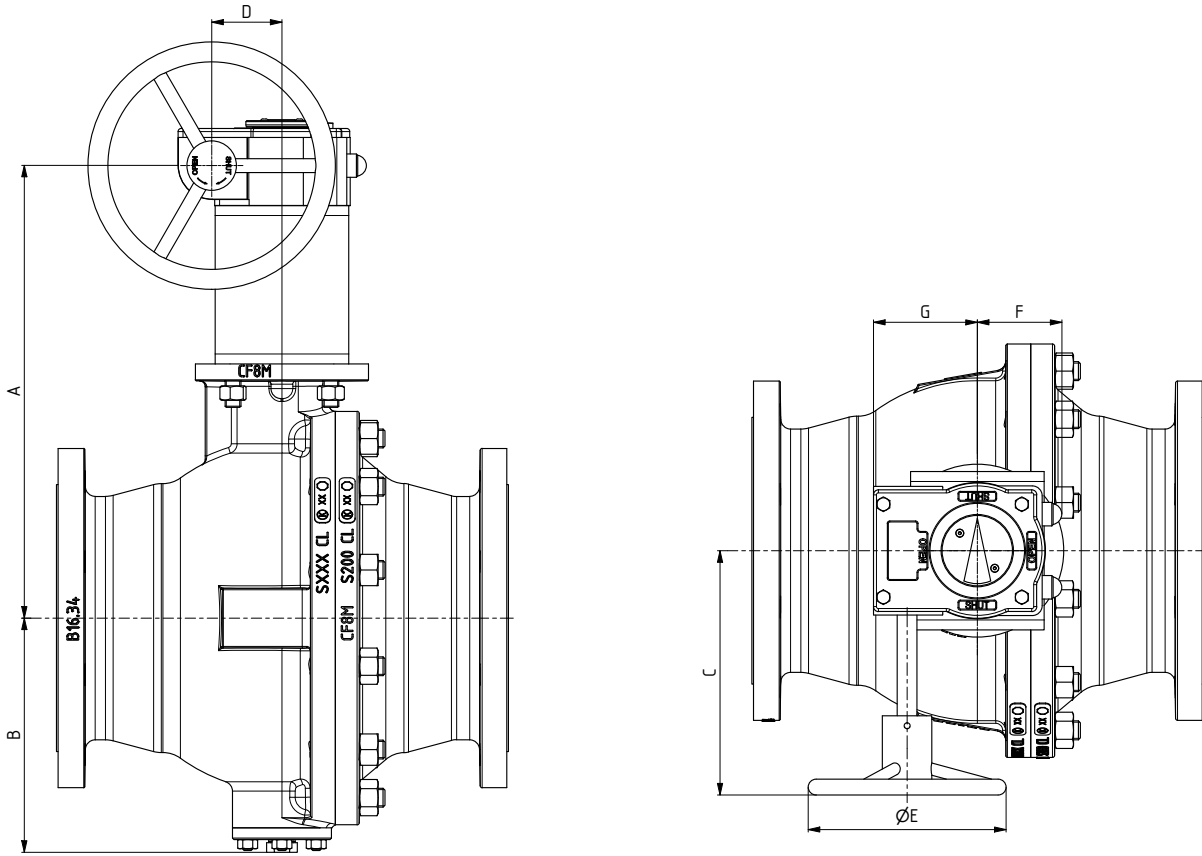

Gear dimensions are for reference only.

DN	NPS	Dimensions (inch)						
		A	B	C	D	ØE	F	G
100	4"	10.87	6.97	8.15	2.05	5.91	1.89	3.15
150	6"	13.15	6.65	10.71	3.39	11.81	3.94	4.96
200	8"	18.07	8.90	10.51	3.39	9.84	3.94	4.96
250	10"	19.76	10.39	10.91	3.39	13.78	3.94	4.96
300	12"	22.95	12.83	13.62	4.13	19.69	4.33	5.83

DN	NPS	Dimensions (mm)						
		A	B	C	D	ØE	F	G
100	4"	276	177	207	52	150	48	80
150	6"	334	169	272	86	300	100	126
200	8"	459	226	267	86	250	100	126
250	10"	502	264	277	86	350	100	126
300	12"	583	326	346	105	500	110	148

Gear size is based on clear, clean liquid fluid at maximum differential pressure.

High Temperature Design with Gears Class 300

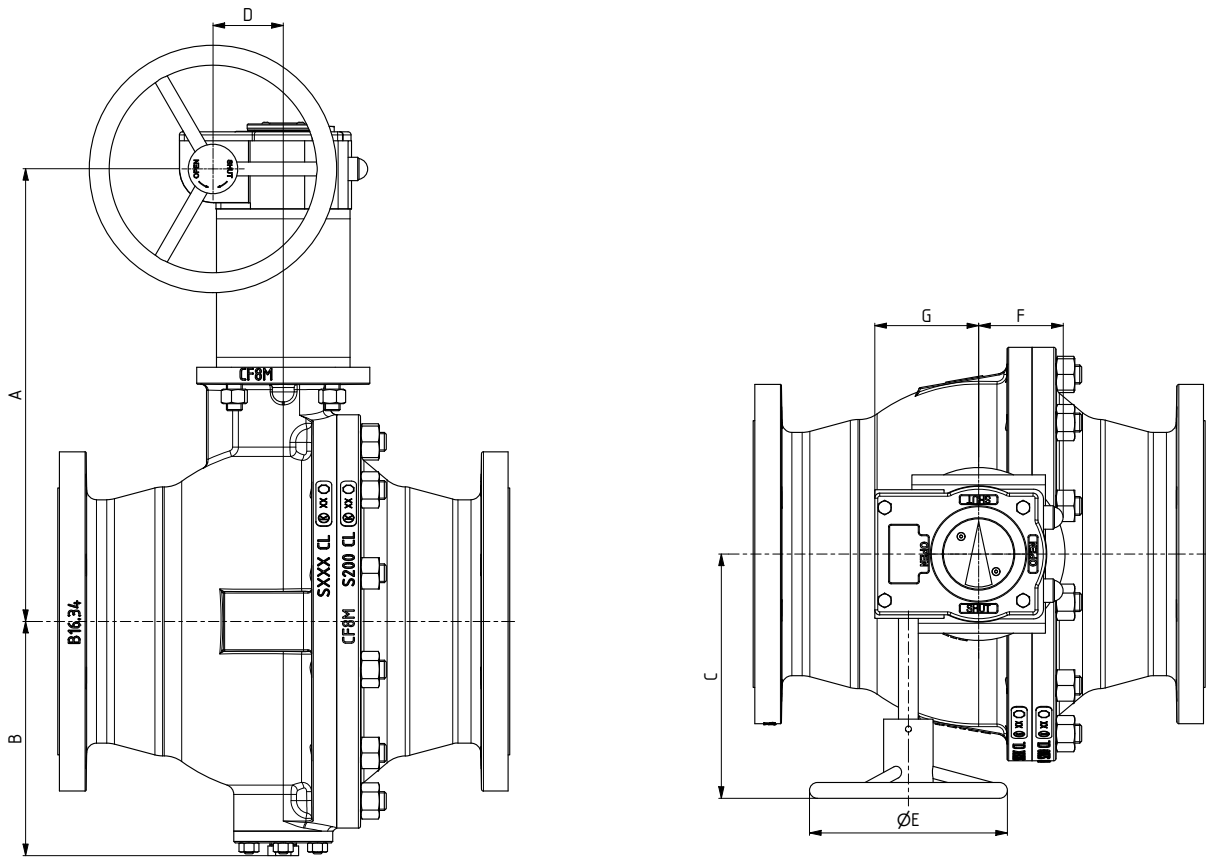

Gear dimensions are for reference only.

DN	NPS	Dimensions (inch)						
		A	B	C	D	ØE	F	G
80	3"	10.91	6.54	9.80	2.80	5.91	2.72	4.13
100	4"	11.54	5.00	10.51	3.39	9.84	3.94	4.96
150	6"	18.39	6.73	13.74	4.17	5.91	5.63	7.09
200	8"	17.87	9.25	13.70	4.13	17.72	4.33	5.83
250	10"	21.46	10.75	13.74	4.17	7.87	5.63	7.09
300	12"	23.50	12.87	15.43	5.51	9.84	5.59	7.68

DN	NPS	Dimensions (mm)						
		A	B	C	D	ØE	F	G
80	3"	277	166	249	71	150	69	105
100	4"	293	127	267	86	250	100	126
150	6"	467	171	349	106	150	143	180
200	8"	454	235	348	105	450	110	148
250	10"	545	273	349	106	200	143	180
300	12"	597	327	392	140	250	142	195

Gear size is based on clear, clean liquid fluid at maximum differential pressure.

High Temperature Design with Gears Class 600

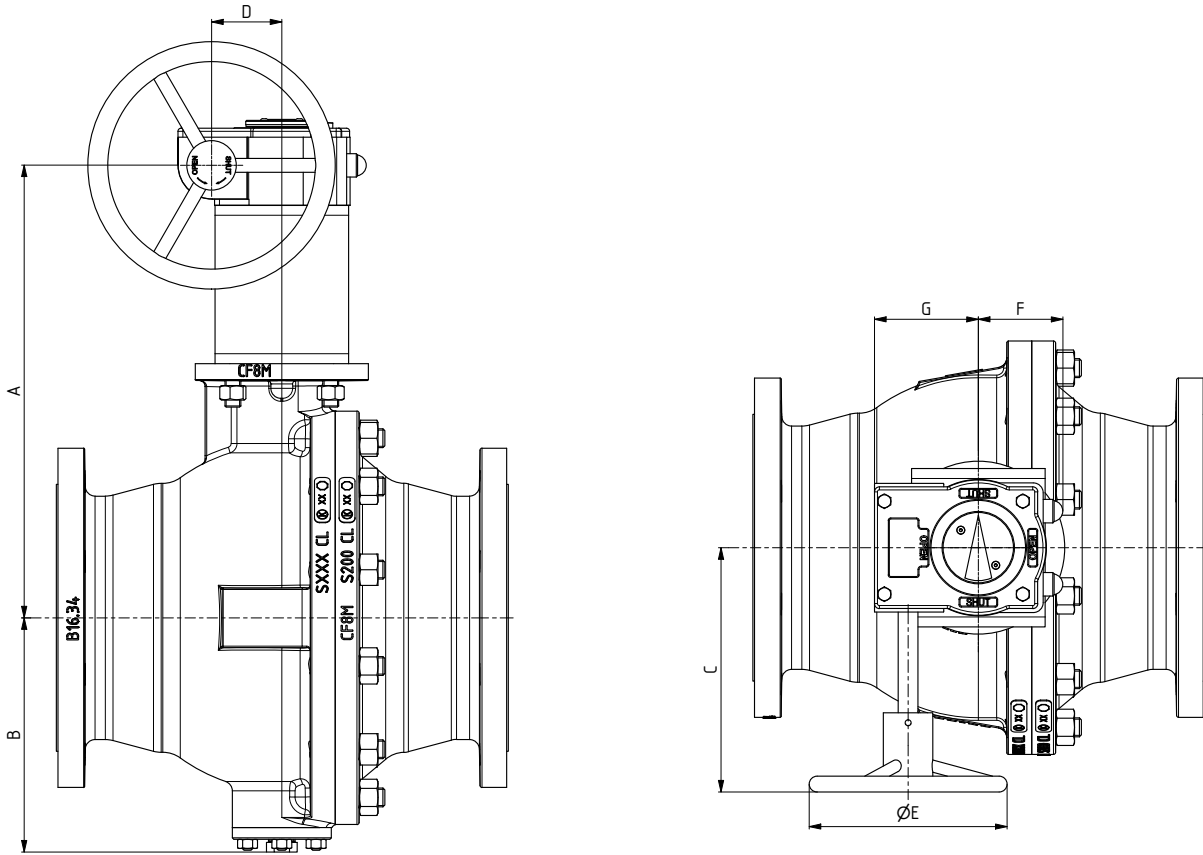

Gear dimensions are for reference only.

DN	NPS	Dimensions (inch)						
		A	B	C	D	ØE	F	G
50	2"	9.06	4.02	8.15	2.05	5.91	1.89	3.15
80	3"	5.63	5.63	10.98	2.80	9.84	2.72	4.13
100	4"	19.57	12.87	15.63	5.51	11.81	5.59	7.68
150	6"	5.98	8.07	13.62	4.13	19.69	4.33	5.83
200	8"	6.30	10.59	15.12	4.17	11.81	5.63	7.09
250	10"	10.55	12.64	15.63	5.51	11.81	5.59	7.68
300	12"	10.51	13.74	17.40	6.61	13.78	6.69	9.37

DN	NPS	Dimensions (mm)						
		A	B	C	D	ØE	F	G
50	2"	230	102	207	52	150	48	80
80	3"	143	143	279	71	250	69	105
100	4"	144	158	279	71	250	69	105
150	6"	152	205	346	105	500	110	148
200	8"	160	269	384	106	300	143	180
250	10"	268	321	397	140	300	142	195
300	12"	267	349	442	168	350	170	238

Gear size is based on clear, clean liquid fluid at maximum differential pressure.

High Temperature Design with Gears Class 900

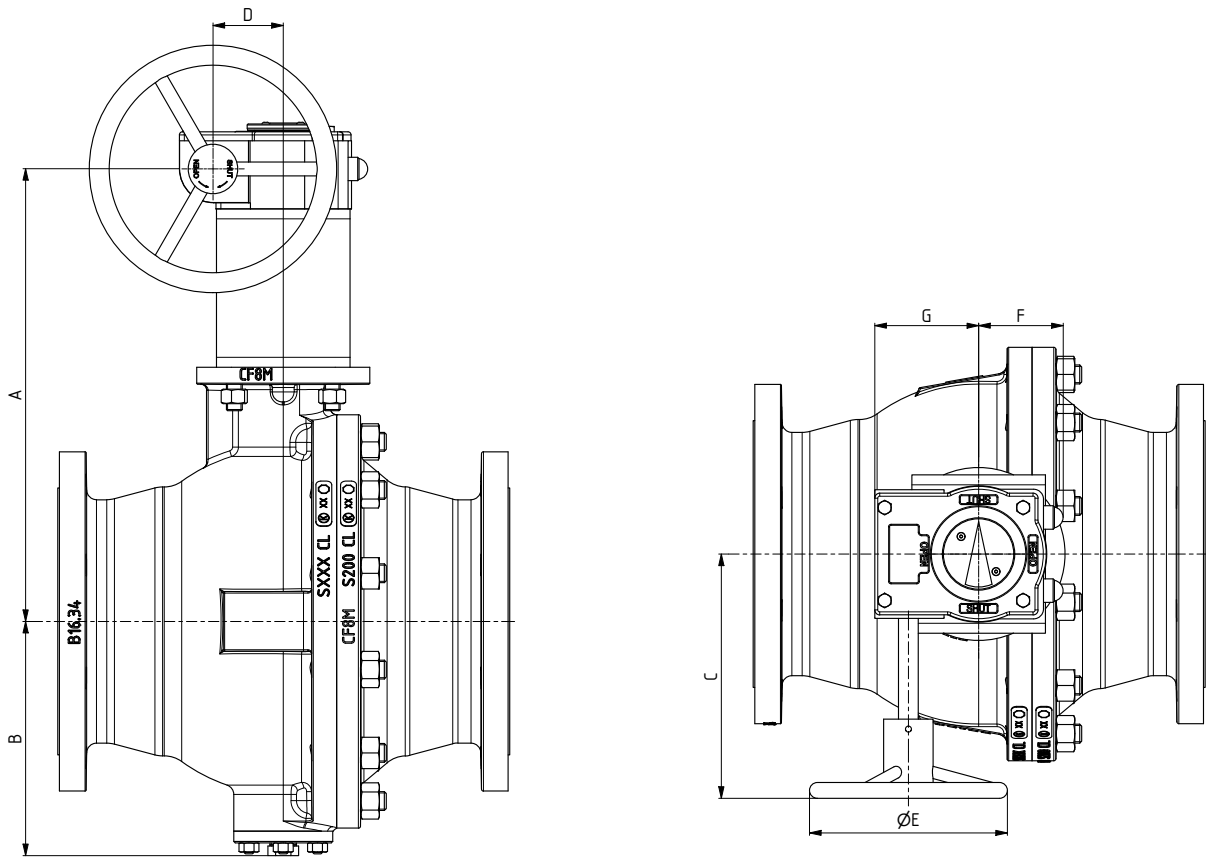

Gear dimensions are for reference only.

DN	NPS	Dimensions (inch)						
		A	B	C	D	ØE	F	G
50	2"	9.06	4.02	8.15	2.05	5.91	1.89	3.15
80	3"	11.34	5.63	10.98	2.80	9.84	2.72	4.13
100	4"	12.83	6.57	12.09	3.39	17.72	3.94	4.96
150	6"	15.63	8.86	12.60	2.09	13.78	5.59	6.22
200	8"	22.36	11.10	15.63	5.51	11.81	5.59	7.68
250	10"	24.17	12.99	17.80	6.61	15.75	6.69	9.37
300	12"	27.80	14.76	18.23	8.23	13.78	8.19	11.18

DN	NPS	Dimensions (mm)						
		A	B	C	D	ØE	F	G
50	2"	230	102	207	52	150	48	80
80	3"	288	143	279	71	250	69	105
100	4"	326	167	307	86	450	100	126
150	6"	397	225	320	53	350	142	158
200	8"	568	282	397	140	300	142	195
250	10"	614	330	452	168	400	170	238
300	12"	706	375	463	209	350	208	284

Gear size is based on clear, clean liquid fluid at maximum differential pressure.

Pressure/Temperature Ratings

	Temperature	ASME class 150	ASME class 300	ASME class 600	ASME class 900
		ASTM A216 Gr. WCB*			
		psi			
Standard Design	-20	285	740	1480	2220
	100	285	740	1480	2220
	200	260	680	1360	2035
	300	230	655	1310	1965
	400	200	635	1265	1900
	500	170	605	1205	1810
	600	140	570	1135	1705
	650	125	550	1100	1650
	700	110	530	1060	1590
	750	95	505	1015	1520
High Temperature Design	800	80	410	825	1235

*according ASME B16.34 - Material Group 1.1

	Temperature	ASME class 150	ASME class 300	ASME class 600	ASME class 900
		ASTM A351 Gr. CF8M*			
		psi			
Standard Design	-76	275	720	1440	2160
	-20	275	720	1440	2160
	100	275	720	1440	2160
	200	235	620	1240	1860
	300	215	560	1120	1680
	400	195	515	1025	1540
	500	170	480	955	1435
	600	140	450	900	1355
	650	125	440	885	1325
	700	110	435	870	1305
High Temperature Design	750	95	425	855	1280
	800	80	420	845	1265

*according ASME B16.34 - Material Group 2.2

Pressure & Temperature
 ASTM A216 Gr. WCB

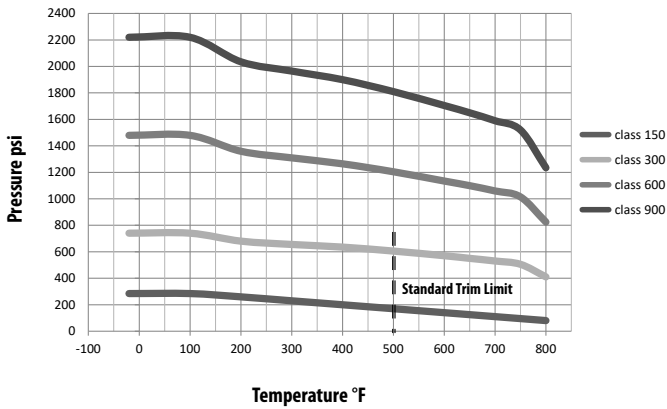

Pressure & Temperature
 ASTM A351 Gr. CF8M

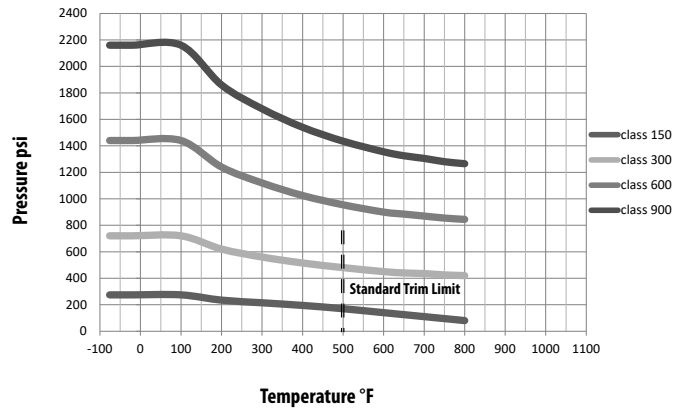

Pressure/Temperature Ratings

	Temperature	ASME class 150	ASME class 300	ASME class 600	ASME class 900	
		ASTM A216 Gr. WCB*				
	°C	bar				
Standard Design	-29	19.6	51.1	102.1	153.2	
	50	19.2	50.1	100.2	150.4	
	100	17.7	46.6	93.2	139.8	
	150	15.8	45.1	90.2	135.2	
	200	13.8	43.8	87.6	131.4	
	250	12.1	41.9	83.9	125.8	
	260	11.7	41.5	83.0	124.5	
	High Temperature Design	300	10.2	39.8	79.6	119.5
		350	8.4	37.6	75.1	112.7
		400	6.5	34.7	69.4	104.2
425		5.5	28.8	57.5	86.3	

*according ASME B16.34 - Material Group 1.1

	Temperature	ASME class 150	ASME class 300	ASME class 600	ASME class 900	
		ASTM A351 Gr. CF8M*				
	°C	bar				
Standard Design	-60	19.0	49.6	99.3	148.9	
	-29	19.0	49.6	99.3	148.9	
	50	18.4	48.1	96.2	144.3	
	100	16.2	42.2	84.4	126.6	
	150	14.8	38.5	77.0	115.5	
	200	13.7	35.7	71.3	107.0	
	250	12.1	33.4	66.8	100.1	
	260	11.7	33.0	66.1	99.1	
	High Temperature Design	300	10.2	31.6	63.2	94.9
		350	8.4	30.3	60.7	91.0
400		6.5	29.4	58.9	88.3	
425		5.5	29.1	58.3	87.4	

*according ASME B16.34 - Material Group 2.2

Pressure & Temperature
ASTM A216 Gr. WCB

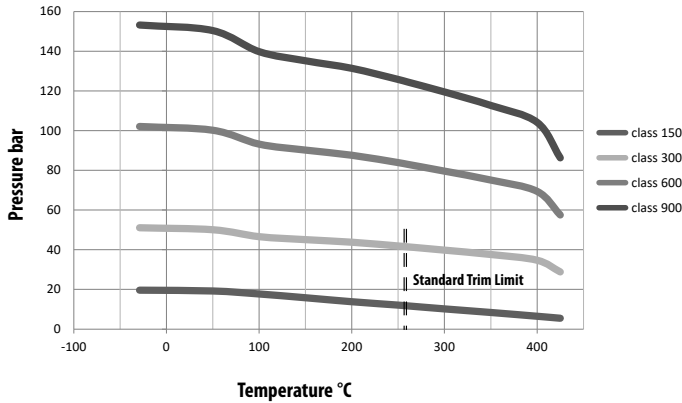

Pressure & Temperature
ASTM A351 Gr. CF8M

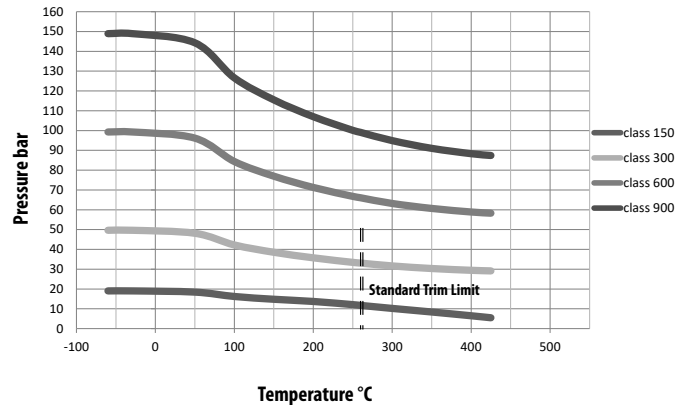

MAST Class 150

Maximum Allowable Stem Torque Class 150

DN	NPS	MAST [in-Lb]						
		Stem Material						
		A276 Gr431 1.4057	A182 F51 1.4462	A564 Gr630 1.4542	A453 Gr660 1.4980	A276 Gr316Ti 1.4571	A276 Gr316 L 1.4404	A286 GrXM-19 1.3964
Floating Ball Design								
15	1/2"	956	744	948	1080	585	470	779
20	3/4"	956	744	948	1080	585	470	779
25	1"	956	744	948	1080	585	470	779
40	1 1/2"	2443	1895	2434	2753	1390	983	1992
50	2"	2443	1895	2434	2753	1390	983	1992
80	3"	7010	5435	6966	7887	3594	2532	5700
100	4"	19269	14932	19154	21676	10506	7409	15657
150	6"	38545	29872	38298	43360	23605	17552	31314
Trunion Design								
200	8"	67346	50282	57805	67346	27385	19304	44900
250	10"	67346	50282	57805	67346	27385	19304	44900
300	12"	130425	97385	111954	130425	53043	37386	86950

DN	NPS	MAST [Nm]						
		Stem Material						
		A276 Gr431 1.4057	A182 F51 1.4462	A564 Gr630 1.4542	A453 Gr660 1.4980	A276 Gr316Ti 1.4571	A276 Gr316 L 1.4404	A286 GrXM-19 1.3964
Floating Ball Design								
15	1/2"	108	84	107	122	66	53	88
20	3/4"	108	84	107	122	66	53	88
25	1"	108	84	107	122	66	53	88
40	1 1/2"	276	214	275	311	157	111	225
50	2"	276	214	275	311	157	111	225
80	3"	792	614	787	891	406	286	644
100	4"	2177	1687	2164	2449	1187	837	1769
150	6"	4355	3375	4327	4899	2667	1983	3538
Trunion Design								
200	8"	7609	5681	6531	7609	3094	2181	5073
250	10"	7609	5681	6531	7609	3094	2181	5073
300	12"	14736	11003	12649	14736	5993	4224	9824

MAST Class 300

Maximum Allowable Stem Torque Class 300

DN	NPS	MAST [in-Lb]						
		Stem Material						
		A276 Gr431 1.4057	A182 F51 1.4462	A564 Gr630 1.4542	A453 Gr660 1.4980	A276 Gr316Ti 1.4571	A276 Gr316 L 1.4404	A286 GrXM-19 1.3964
Floating Ball Design								
15	1/2"	956	744	948	1080	585	470	779
20	3/4"	956	744	948	1080	585	470	779
25	1"	956	744	948	1080	585	470	779
40	1 1/2"	2443	1895	2434	2753	1390	983	1992
50	2"	7010	5435	6966	7887	3594	2532	5700
80	3"	19269	14932	19154	21676	10506	7409	15657
100	4"	38545	29872	38298	43360	23605	17552	31314
150	6"	121318	97385	111954	121318	53043	37386	86950
Trunion Design								
200	8"	104227	97385	104227	104227	53043	37386	86950
250	10"	130425	97385	111954	130425	53043	37386	86950
300	12"	223677	176989	203461	223677	96394	67957	158031

DN	NPS	MAST [Nm]						
		Stem Material						
		A276 Gr431 1.4057	A182 F51 1.4462	A564 Gr630 1.4542	A453 Gr660 1.4980	A276 Gr316Ti 1.4571	A276 Gr316 L 1.4404	A286 GrXM-19 1.3964
Floating Ball Design								
15	1/2"	108	84	107	122	66	53	88
20	3/4"	108	84	107	122	66	53	88
25	1"	108	84	107	122	66	53	88
40	1 1/2"	276	214	275	311	157	111	225
50	2"	792	614	787	891	406	286	644
80	3"	2177	1687	2164	2449	1187	837	1769
100	4"	4355	3375	4327	4899	2667	1983	3538
150	6"	13707	11003	12649	13707	5993	4224	9824
Trunion Design								
200	8"	11776	11003	11776	11776	5993	4224	9824
250	10"	14736	11003	12649	14736	5993	4224	9824
300	12"	25272	19997	22988	25272	10891	7678	17855

MAST Class 600

Maximum Allowable Stem Torque Class 600

DN	NPS	MAST [in-Lb]						
		Stem Material						
		A276 Gr431 1.4057	A182 F51 1.4462	A564 Gr630 1.4542	A453 Gr660 1.4980	A276 Gr316Ti 1.4571	A276 Gr316 L 1.4404	A286 GrXM-19 1.3964
Floating Ball Design								
15	1/2"	744	744	744	744	664	470	744
20	3/4"	1266	1266	1266	1266	1266	983	1266
25	1"	1930	1930	1930	1930	1930	1771	1930
40	1 1/2"	2611	2611	2611	2611	2611	2532	2611
Trunion Design								
50	2"	10657	9382	10657	10657	5090	3585	8338
80	3"	20127	20127	20127	20127	10913	7692	17897
100	4"	21251	21251	21251	21251	13064	9205	21251
150	6"	68346	68346	68346	68346	42458	29934	68346
200	8"	99952	99952	99952	99952	70240	49512	99952
250	10"	156570	156570	156570	156570	96412	67957	156570
300	12"	243378	243378	243378	243378	157278	110865	243378

DN	NPS	MAST [Nm]						
		Stem Material						
		A276 Gr431 1.4057	A182 F51 1.4462	A564 Gr630 1.4542	A453 Gr660 1.4980	A276 Gr316Ti 1.4571	A276 Gr316 L 1.4404	A286 GrXM-19 1.3964
Floating Ball Design								
15	1/2"	84	84	84	84	75	53	84
20	3/4"	143	143	143	143	143	111	143
25	1"	218	218	218	218	218	200	218
40	1 1/2"	295	295	295	295	295	286	295
Trunion Design								
50	2"	1204	1060	1204	1204	575	405	942
80	3"	2274	2274	2274	2274	1233	869	2022
100	4"	2401	2401	2401	2401	1476	1040	2401
150	6"	7722	7722	7722	7722	4797	3382	7722
200	8"	11293	11293	11293	11293	7936	5594	11293
250	10"	17690	17690	17690	17690	10893	7678	17690
300	12"	27498	27498	27498	27498	17770	12526	27498

Maximum Allowable Stem Torque Class 900

DN	NPS	MAST [in-Lb]						
		Stem Material						
		A276 Gr431 1.4057	A182 F51 1.4462	A564 Gr630 1.4542	A453 Gr660 1.4980	A276 Gr316Ti 1.4571	A276 Gr316 L 1.4404	A286 GrXM-19 1.3964
Floating Ball Design								
15	1/2"	1266	1266	1266	1266	1266	983	1266
20	3/4"	1266	1266	1266	1266	1266	983	1266
25	1"	1930	1930	1930	1930	1930	1771	1930
40	1 1/2"	2611	2611	2611	2611	2611	2532	2611
Trunion Design								
50	2"	10657	9382	10657	10657	5090	3585	8338
80	3"	20127	20127	20127	20127	10913	7692	17897
100	4"	29580	29580	29580	29580	18383	12958	29580
150	6"	68346	68346	68346	68346	42458	29934	68346
200	8"	156570	156570	156570	156570	96412	67957	156570
250	10"	243378	243378	243378	243378	157278	110865	243378
300	12"	389690	389690	389690	389690	244653	172457	389690

DN	NPS	MAST [Nm]						
		Stem Material						
		A276 Gr431 1.4057	A182 F51 1.4462	A564 Gr630 1.4542	A453 Gr660 1.4980	A276 Gr316Ti 1.4571	A276 Gr316 L 1.4404	A286 GrXM-19 1.3964
Floating Ball Design								
15	1/2"	143	143	143	143	143	111	143
20	3/4"	143	143	143	143	143	111	143
25	1"	218	218	218	218	218	200	218
40	1 1/2"	295	295	295	295	295	286	295
Trunion Design								
50	2"	1204	1060	1204	1204	575	405	942
80	3"	2274	2274	2274	2274	1233	869	2022
100	4"	3342	3342	3342	3342	2077	1464	3342
150	6"	7722	7722	7722	7722	4797	3382	7722
200	8"	17690	17690	17690	17690	10893	7678	17690
250	10"	27498	27498	27498	27498	17770	12526	27498
300	12"	44029	44029	44029	44029	27642	19485	44029

Operating Torques

Torques Class 150

DN	NPS	Torque [in-Lb]						
		BTO	RUN	ETO		BTC	RUN	ETC
Floating Ball Design								
15	1/2"	89	80	80		89	80	80
20	3/4"	106	80	89		97	80	89
25	1"	124	89	89		97	89	97
40	1 1/2"	283	168	177		195	168	212
50	2"	451	221	239		266	221	319
80	3"	1372	566	611		673	566	903
100	4"	3009	1275	1345		1478	1275	1974
150	6"	8922	3284	3576		3939	3284	5656
Trunion Design								
200	8"	6125	2894	3124		3434	2894	3779
250	10"	8868	4027	4443		4886	4027	5355
300	12"	16285	7373	8036		8842	7373	9966

Torques Class 300

DN	NPS	Torque [in-Lb]						
		BTO	RUN	ETO		BTC	RUN	ETC
Floating Ball Design								
15	1/2"	115	80	89		97	80	97
20	3/4"	142	89	89		106	89	115
25	1"	195	97	106		115	97	142
40	1 1/2"	496	204	212		239	204	319
50	2"	1053	451	469		522	451	690
80	3"	3381	1275	1319		1443	1275	2106
100	4"	6753	2292	2363		2593	2292	4045
150	6"	21375	6576	6868		7559	6576	12497
Trunion Design								
200	8"	13940	5974	6196		6815	5974	8674
250	10"	20118	7948	8355		9187	7948	12028
300	12"	33934	12745	13409		14745	12745	19658

DN	NPS	Torque [Nm]						
		BTO	RUN	ETO		BTC	RUN	ETC
Floating Ball Design								
15	1/2"	10	9	9		10	9	9
20	3/4"	12	9	10		11	9	10
25	1"	14	10	10		11	10	11
40	1 1/2"	32	19	20		22	19	24
50	2"	51	25	27		30	25	36
80	3"	155	64	69		76	64	102
100	4"	340	144	152		167	144	223
150	6"	1008	371	404		445	371	639
Trunion Design								
200	8"	692	327	353		388	327	427
250	10"	1002	455	502		552	455	605
300	12"	1840	833	908		999	833	1126

DN	NPS	Torque [Nm]						
		BTO	RUN	ETO		BTC	RUN	ETC
Floating Ball Design								
15	1/2"	13	9	10		11	9	11
20	3/4"	16	10	10		12	10	13
25	1"	22	11	12		13	11	16
40	1 1/2"	56	23	24		27	23	36
50	2"	119	51	53		59	51	78
80	3"	382	144	149		163	144	238
100	4"	763	259	267		293	259	457
150	6"	2415	743	776		854	743	1412
Trunion Design								
200	8"	1575	675	700		770	675	980
250	10"	2273	898	944		1038	898	1359
300	12"	3834	1440	1515		1666	1440	2221

The torques shown in the chart are for reference only (liquid, 260°C, BH Packing, Safety=1.0). For application-specific torques, please consult the factory.

BTO = Break to open
 RUN = Running
 ETO = End to open

BTC = Break to close
 RUN = Running
 ETC = End to close

Operating Torques

Torques Class 600

DN	NPS	Torque [in-Lb]						
		BTO	RUN	ETO		BTC	RUN	ETC
Floating Ball Design								
15	1/2"	177	115	115		124	115	142
20	3/4"	292	177	177		195	177	221
25	1"	531	319	319		354	319	389
40	1 1/2"	1248	637	646		708	637	859
Trunion Design								
50	2"	2018	1106	1177		1292	1106	1407
80	3"	4470	2390	2576		2832	2390	3089
100	4"	6682	3222	3514		3868	3222	4372
150	6"	17958	8479	9116		10019	8479	11816
200	8"	35854	15046	16170		17790	15046	22322
250	10"	53874	22746	24729		27198	22746	33589
300	12"	93552	36890	40129		44139	36890	56521

Torques Class 900

DN	NPS	Torque [in-Lb]						
		BTO	RUN	ETO		BTC	RUN	ETC
Floating Ball Design								
15	1/2"	274	177	177		195	177	212
20	3/4"	372	195	204		221	195	266
25	1"	664	354	363		398	354	469
40	1 1/2"	1629	726	735		805	726	1062
Trunion Design								
50	2"	2620	1292	1363		1496	1292	1752
80	3"	5859	2823	3000		3301	2823	3868
100	4"	10594	4788	5089		5594	4788	6886
150	6"	24109	10170	10807		11887	10170	15179
200	8"	51467	20578	21711		23879	20578	31756
250	10"	83949	31765	33748		37129	31765	50812
300	12"	149985	56193	59433		65372	56193	90286

DN	NPS	Torque [Nm]						
		BTO	RUN	ETO		BTC	RUN	ETC
Floating Ball Design								
15	1/2"	20	13	13		14	13	16
20	3/4"	33	20	20		22	20	25
25	1"	60	36	36		40	36	44
40	1 1/2"	141	72	73		80	72	97
Trunion Design								
50	2"	228	125	133		146	125	159
80	3"	505	270	291		320	270	349
100	4"	755	364	397		437	364	494
150	6"	2029	958	1030		1132	958	1335
200	8"	4051	1700	1827		2010	1700	2522
250	10"	6087	2570	2794		3073	2570	3795
300	12"	10570	4168	4534		4987	4168	6386

DN	NPS	Torque [Nm]						
		BTO	RUN	ETO		BTC	RUN	ETC
Floating Ball Design								
15	1/2"	31	20	20		22	20	24
20	3/4"	42	22	23		25	22	30
25	1"	75	40	41		45	40	53
40	1 1/2"	184	82	83		91	82	120
Trunion Design								
50	2"	296	146	154		169	146	198
80	3"	662	319	339		373	319	437
100	4"	1197	541	575		632	541	778
150	6"	2724	1149	1221		1343	1149	1715
200	8"	5815	2325	2453		2698	2325	3588
250	10"	9485	3589	3813		4195	3589	5741
300	12"	16946	6349	6715		7386	6349	10201

The torques shown in the chart are for reference only (liquid, 260°C, BH Packing, Safety=1.0). For application-specific torques, please consult the factory.

BTO = Break to open
 RUN = Running
 ETO = End to open

BTC = Break to close
 RUN = Running
 ETC = End to close

Packing Gland Nut Torques

Packing gland nut torques Class 150

DN	NPS	Thread Size	Standard Trim	High Temperature Trim
			[in-Lb]	[in-Lb]
15	1/2"	M30x1	1027	1027
20	3/4"	M30x1	1027	1027
25	1"	M30x1	1027	1027
40	1 1/2"	M36x1,5	1983	1983
50	2"	M36x1,5	1983	1983
80	3"	M48x1,5	4337	3443
100	4"	7/16" -14 UNC	239	160
150	6"	7/16" -14 UNC	213	151
200	8"	5/8" -11 UNC	1231	850
250	10"	5/8" -11 UNC	1231	850
300	12"	1" -8 UNC	3089	3098

Packing gland nut torques Class 300

DN	NPS	Thread Size	Standard Trim	High Temperature Trim
			[in-Lb]	[in-Lb]
15	1/2"	M30x1	1027	1027
20	3/4"	M30x1	1027	1027
25	1"	M30x1	1027	1027
40	1 1/2"	M36x1,5	1983	1983
50	2"	M48x1,5	4337	3443
80	3"	7/16" -14 UNC	239	160
100	4"	7/16" -14 UNC	213	151
150	6"	1/2" -13UNC	390	390
200	8"	1" -8 UNC	3089	3098
250	10"	1" -8 UNC	3089	3098
300	12"	1" -8 UNC	3497	3497

DN	NPS	Thread Size	Standard Trim	High Temperature Trim
			[Nm]	[Nm]
15	1/2"	M30x1	116	116
20	3/4"	M30x1	116	116
25	1"	M30x1	116	116
40	1 1/2"	M36x1,5	224	224
50	2"	M36x1,5	224	224
80	3"	M48x1,5	490	389
100	4"	7/16" -14 UNC	27	18
150	6"	7/16" -14 UNC	24	17
200	8"	5/8" -11 UNC	139	96
250	10"	5/8" -11 UNC	139	96
300	12"	1" -8 UNC	349	350

DN	NPS	Thread Size	Standard Trim	High Temperature Trim
			[Nm]	[Nm]
15	1/2"	M30x1	116	116
20	3/4"	M30x1	116	116
25	1"	M30x1	116	116
40	1 1/2"	M36x1,5	224	224
50	2"	M48x1,5	490	389
80	3"	7/16" -14 UNC	27	18
100	4"	7/16" -14 UNC	24	17
150	6"	1/2" -13UNC	44	44
200	8"	1" -8 UNC	349	350
250	10"	1" -8 UNC	349	350
300	12"	1" -8 UNC	395	395

Packing Gland Nut Torques

Packing gland nut torques Class 600

DN	NPS	Thread Size	High Temperature Trim [in-Lb]
Floating Ball Design			
15	1/2"	M30 x 1	1027
20	3/4"	M32 x 1.5	1417
25	1"	M42 x 1.5	1983
40	1 1/2"	M48 x 1.5	3452
Trunion Design			
50	2"	7/16" -14 UNC	443
80	3"	7/16" -14 UNC	443
100	4"	7/16" -14 UNC	443
150	6"	3/4" -10 UNC	2328
200	8"	3/4" -10 UNC	2328
250	10"	3/4" -10 UNC	2328
300	12"	7/8" -9 UNC	3718

Packing gland nut torques Class 900

DN	NPS	Thread Size	High Temperature Trim [in-Lb]
Floating Ball Design			
15	1/2"	M32 x 1.5	1417
20	3/4"	M32 x 1.5	1417
25	1"	M42 x 1.5	1983
40	1 1/2"	M48 x 1.5	3452
Trunion Design			
50	2"	7/16" -14 UNC	443
80	3"	7/16" -14 UNC	443
100	4"	1/2" -13 UNC	673
150	6"	3/4" -10 UNC	2328
200	8"	3/4" -10 UNC	2328
250	10"	7/8" -9 UNC	3718
300	12"	1" -8 UNC	5532

DN	NPS	Thread Size	High Temperature Trim [Nm]
Floating Ball Design			
15	1/2"	M30 x 1	116
20	3/4"	M32 x 1.5	160
25	1"	M42 x 1.5	224
40	1 1/2"	M48 x 1.5	390
Trunion Design			
50	2"	7/16" -14 UNC	50
80	3"	7/16" -14 UNC	50
100	4"	7/16" -14 UNC	50
150	6"	3/4" -10 UNC	263
200	8"	3/4" -10 UNC	263
250	10"	3/4" -10 UNC	263
300	12"	7/8" -9 UNC	420

DN	NPS	Thread Size	High Temperature Trim [Nm]
Floating Ball Design			
15	1/2"	M32 x 1.5	160
20	3/4"	M32 x 1.5	160
25	1"	M42 x 1.5	224
40	1 1/2"	M48 x 1.5	390
Trunion Design			
50	2"	7/16" -14 UNC	50
80	3"	7/16" -14 UNC	50
100	4"	1/2" -13 UNC	76
150	6"	3/4" -10 UNC	263
200	8"	3/4" -10 UNC	263
250	10"	7/8" -9 UNC	420
300	12"	1" -8 UNC	625

Body Joint

Body joint torques Class 150

DN	NPS	Thread Size	[in-Lb]
Floating Ball Design			
15	1/2"	5/16" -18 UNC	142
20	3/4"	5/16" -18 UNC	142
25	1"	5/16" -18 UNC	142
40	1 1/2"	7/16" -14 UNC	389
50	2"	7/16" -14 UNC	389
80	3"	5/8" -11 UNC	1195
100	4"	1/2" -13 UNC	637
150	6"	3/4" -10 UNC	2106
Trunion Design			
200	8"	3/4" -10 UNC	2106
250	10"	3/4" -10 UNC	2106
300	12"	7/8" -9 UNC	3009

DN	NPS	Thread Size	[Nm]
Floating Ball Design			
15	1/2"	5/16" -18 UNC	16
20	3/4"	5/16" -18 UNC	16
25	1"	5/16" -18 UNC	16
40	1 1/2"	7/16" -14 UNC	44
50	2"	7/16" -14 UNC	44
80	3"	5/8" -11 UNC	135
100	4"	1/2" -13 UNC	72
150	6"	3/4" -10 UNC	238
Trunion Design			
200	8"	3/4" -10 UNC	238
250	10"	3/4" -10 UNC	238
300	12"	7/8" -9 UNC	340

Body joint torques Class 300

DN	NPS	Thread Size	[in-Lb]
Floating Ball Design			
15	1/2"	3/8" -16 UNC	248
20	3/4"	3/8" -16 UNC	248
25	1"	3/8" -16 UNC	248
40	1 1/2"	1/2" -13 UNC	637
50	2"	5/8" -11 UNC	1195
80	3"	5/8" -11 UNC	1195
100	4"	5/8" -11 UNC	1195
150	6"	3/4" -10 UNC	2106
Trunion Design			
200	8"	3/4" -10 UNC	2106
250	10"	7/8" -9 UNC	3009
300	12"	1" -8 UNC	4425

DN	NPS	Thread Size	[Nm]
Floating Ball Design			
15	1/2"	3/8" -16 UNC	28
20	3/4"	3/8" -16 UNC	28
25	1"	3/8" -16 UNC	28
40	1 1/2"	1/2" -13 UNC	72
50	2"	5/8" -11 UNC	135
80	3"	5/8" -11 UNC	135
100	4"	5/8" -11 UNC	135
150	6"	3/4" -10 UNC	238
Trunion Design			
200	8"	3/4" -10 UNC	238
250	10"	7/8" -9 UNC	340
300	12"	1" -8 UNC	500

Body joint torques Class 600

DN	NPS	Thread Size	[in-Lb]
Floating Ball Design			
15	1/2"	1/2" -13 UNC	673
20	3/4"	9/16" -12 UNC	947
25	1"	9/16" -12 UNC	947
40	1 1/2"	3/4" -10 UNC	2328
Trunion Design			
50	2"	1/2" -13 UNC	673
80	3"	3/4" -10 UNC	2328
100	4"	7/8" -9 UNC	3717
150	6"	1" -8 UNC	5532
200	8"	1 1/4" -8 UNC	11258
250	10"	1 3/8" -8 UNC	15099
300	12"	1 3/8" -8 UNC	15099

DN	NPS	Thread Size	[Nm]
Floating Ball Design			
15	1/2"	1/2" -13 UNC	76
20	3/4"	9/16" -12 UNC	107
25	1"	9/16" -12 UNC	107
40	1 1/2"	3/4" -10 UNC	263
Trunion Design			
50	2"	1/2" -13 UNC	76
80	3"	3/4" -10 UNC	263
100	4"	7/8" -9 UNC	420
150	6"	1" -8 UNC	625
200	8"	1 1/4" -8 UNC	1272
250	10"	1 3/8" -8 UNC	1706
300	12"	1 3/8" -8 UNC	1706

Body joint torques Class 900

DN	NPS	Thread Size	[in-Lb]
Floating Ball Design			
15	1/2"	9/16" -12 UNC	947
20	3/4"	5/8" -11 UNC	1319
25	1"	5/8" -11 UNC	1319
40	1 1/2"	7/8" -9 UNC	3717
Trunion Design			
50	2"	9/16" -12 UNC	947
80	3"	7/8" -9 UNC	3717
100	4"	1" -8 UNC	5532
150	6"	1 1/8" -8 UNC	8063
200	8"	1 1/2" -8 UNC	17640
250	10"	1 3/4" -8 UNC	31951
300	12"	1 3/4" -8 UNC	31951

DN	NPS	Thread Size	[Nm]
Floating Ball Design			
15	1/2"	9/16" -12 UNC	107
20	3/4"	5/8" -11 UNC	149
25	1"	5/8" -11 UNC	149
40	1 1/2"	7/8" -9 UNC	420
Trunion Design			
50	2"	9/16" -12 UNC	107
80	3"	7/8" -9 UNC	420
100	4"	1" -8 UNC	625
150	6"	1 1/8" -8 UNC	911
200	8"	1 1/2" -8 UNC	1993
250	10"	1 3/4" -8 UNC	3610
300	12"	1 3/4" -8 UNC	3610

Cover Torques

Cover torques Class 150

DN	NPS	Thread Size	[in-Lb]
Floating Ball Design			
15-150	1/2"-6"	N/A	N/A
Trunion Design			
200	8"	3/8" -16 UNC	248
250	10"	3/8" -16 UNC	248
300	12"	3/8" -16 UNC	248

DN	NPS	Thread Size	[Nm]
Floating Ball Design			
15-150	1/2"-6"	N/A	N/A
Trunion Design			
200	8"	3/8" -16 UNC	28
250	10"	3/8" -16 UNC	28
300	12"	3/8" -16 UNC	28

Cover torques Class 300

DN	NPS	Thread Size	[in-Lb]
Floating Ball Design			
15-150	1/2"-6"	N/A	N/A
Trunion Design			
200	8"	3/8" -16 UNC	248
250	10"	3/8" -16 UNC	248
300	12"	3/8" -16 UNC	248

DN	NPS	Thread Size	[Nm]
Floating Ball Design			
15-150	1/2"-6"	N/A	N/A
Trunion Design			
200	8"	3/8" -16 UNC	28
250	10"	3/8" -16 UNC	28
300	12"	3/8" -16 UNC	28

Cover torques Class 600

DN	NPS	Thread Size	[in-Lb]
Trunion Design			
50	2"	1/2" -13 UNC	673
80	3"	1/2" -13 UNC	673
100	4"	1/2" -13 UNC	673
150	6"	5/8" -11 UNC	1319
200	8"	3/4" -10 UNC	2328
250	10"	7/8" -9 UNC	3718
300	12"	7/8" -9 UNC	3718

DN	NPS	Thread Size	[Nm]
Trunion Design			
50	2"	1/2" -13 UNC	76
80	3"	1/2" -13 UNC	76
100	4"	1/2" -13 UNC	76
150	6"	5/8" -11 UNC	149
200	8"	3/4" -10 UNC	263
250	10"	7/8" -9 UNC	420
300	12"	7/8" -9 UNC	420

Cover torques Class 900

DN	NPS	Thread Size	[in-Lb]
Trunion Design			
50	2"	1/2" -13 UNC	673
80	3"	9/16" -12 UNC	948
100	4"	5/8" -11 UNC	1319
150	6"	3/4" -10 UNC	2328
200	8"	7/8" -9 UNC	3718
250	10"	7/8" -9 UNC	3718
300	12"	1" -8 UNC	5532

DN	NPS	Thread Size	[Nm]
Trunion Design			
50	2"	1/2" -13 UNC	76
80	3"	9/16" -12 UNC	107
100	4"	5/8" -11 UNC	149
150	6"	3/4" -10 UNC	263
200	8"	7/8" -9 UNC	420
250	10"	7/8" -9 UNC	420
300	12"	1" -8 UNC	625

Kv / Cv Values

Kv / Cv Values Class 150-900

DN	NPS	Class 150		Class 300		Class 600		Class 900	
		90°		90°		90°		90°	
		Kv	Cv	Kv	Cv	Kv	Cv	Kv	Cv
15	1/2"	13	15	11	13	10	12	9	10
20	3/4"	33	38	29	34	26	30	23	27
25	1"	65	75	56	65	48	56	44	51
40	1 1/2"	172	200	159	184	139	161	121	140
50	2"	322	374	289	335	244	283	213	247
80	3"	1021	1184	849	985	743	862	715	829
100	4"	1839	2133	1566	1817	1283	1488	1242	1441
150	6"	4109	4766	4058	4707	3377	3917	3213	3727
200	8"	8145	9448	7730	8967	6626	7686	6221	7216
250	10"	13415	15561	12948	15020	10776	12500	10397	12061
300	12"	20250	23490	19580	22713	16947	19659	15639	18141

Product Coding

PRODUCT LINE				DESIGN						
Valve	General Design	Bonnet	Valve Type	Size	Pressure Class	Seat Type	Sealing System	Bore Size	End Connection	Face to Face
KFO	1	1	76	G	D	B	1	1	A	1

PRODUCT LINE

Valve	
Standard Flange Ball Valve	KFO

General Design	
cast split body, floating	1
forged split body, floating	5
forged split body, trunnion mounted	7
cast split body, trunnion mounted	9

Bonnet	
Standard	1
Bonnet extension	2

Valve Type	
Performance Series (425°C/800°F)	56
Performance Series (260°C/500°F)	76

DESIGN

Nominal pipe size		
1/2"	DN 15	B
3/4"	DN 20	C
1"	DN 25	D
1-1/2"	DN 40	F
2"	DN 50	G
3"	DN 80	I
4"	DN 100	J
6"	DN 150	L
8"	DN 200	M
10"	DN 250	N
12"	DN 300	O

Pressure Class	
Class 150	D
Class 300	G
Class 600	K
Class 900	L

Seat Type	
Double Seat/ Bi-Directional	B

Sealing System	
Standard Sealing System	1

Bore Size	
Full Port	1

Connection	
Flanged - ASME B16.5 RF	A

Face to Face	
ASME B16.10 Long	1

Product Coding

MATERIAL						OTHER			OPERATION	OPTIONS
Body Material	Stem Material	Stem Seal	Ball Base Material	Seat Base Material	Coating System	Maximum Temperature	Jacket	Drain/ Purge Ports	Operator	Options
B	H	2	F	F	2	B	0	0	F	0

MATERIAL

Body Material	
ASTM A216 Gr. WCB	A
ASTM A351 Gr. CF8M	B
ASTM A995 Gr. 5A - Superduplex	C
ASTM A352 Gr. LCB	E
ASTM A352 Gr. LCC	F
ASTM A217 Gr. WC6	G
ASTM A494 Gr. CY40	J
ASTM A351 Gr. CN7M	K
ASTM A351 Gr. CT15C	L
ASTM A494 Gr. M35-1	M
ASTM A351 Gr. CF3M	N
ASTM A995 Gr. 6A	R
ASTM A494 Gr. CX2MW	T
Other	X

Stem Material	
ASTM A564 Gr. 630 (17-4 PH), H1150-D	A
ASTM A276 Gr. 420 (UNS S42000)	B
ASTM A276 Gr 316Ti (UNS S31635)	C
ASTM A182 Gr. F51 (UNS S31803)	D
ASTM A638 Gr. 660 (UNS S66286)	E
ASTM A286 Gr. XM-19	F
ASTM A276 Gr. 431 (UNS S43100)	H
ASTM A182 Gr. F316L (UNS S31603)	I
Other	X

Stem Seal (Packing)	
Standard Graphite	1
Fugitive Emission Packing (ISO15484/API-641)	2

Ball Base Material	
ASTM A276 Gr 316Ti (UNS S31635)	C
ASTM A182 Gr. F51 (UNS S31803)	D
ASTM A638 Gr. 660 (UNS S66286)	E
ASTM A182 Gr. F316L (UNS S31603)	F
Other	X

Seat Base Material	
ASTM A276 Gr 316Ti (UNS S31635)	C
ASTM A182 Gr. F51 (UNS S31803)	D
ASTM A638 Gr. 660 (UNS S66286)	E
ASTM A182 Gr. F316L (UNS S31603)	F
Other	X

Coating System		
H3	Ball: M3 Nickel/Chrome (NiCr) Seat: M3 Nickel/Chrome (NiCr)	2
H4	Ball: M6 Nickel/Chrome/Tungsten Carbide (NiCr-WC) Seat: M3 Nickel/Chrome (NiCr)	3
H5	Ball: M4 Cobalt based (Stellite SF20) Seat: M4 Cobalt based (Stellite SF20)	4
H6	Ball: M11 Chromium Carbide/Nickel/Chromium (Cr3C2-NiCr) Seat: M11 Chromium Carbide/Nickel/Chromium (Cr3C2-NiCr)	5
H10	Ball: M12 Tungsten Carbide Seat: M12 Tungsten Carbide	6
H11	Ball: M2 Hard Chromium (Cr) Seat: M2 Hard Chromium (Cr)	7

OTHER

Maximum Temperature	
260°C / 500°F	B
425°C / 800°F	C

Heating Jacket	
None	0

Drain/Purge Ports	
None	0

OPERATION

Operator	
Bare Stem	F
Lever - Locking	L
Gear (manual)	G
Actuated (pneumatic, hydraulic, electric)	A
Mounting kit w/o Operator	M
Extended Lever	J
Stem Extension	H
Stem Extension with Locking Lever	O
Stem Extension with Gear	P
Stem Extension with Actuator	R
Other	X

OPTIONS

Options	
None	0
NACE MR 0103 or 0175	1
Special	X

CRANE[®]

CRANE CHEMPHARMA & ENERGY

Xomox International GmbH & Co. OHG
Armaturenwerke
Marburger Str. 364
57223 Kreuztal, Germany
Tel.: +49 2732 520 00

Crane International Trading (Beijing) Co., Ltd.
Room 1103, Capital Tower 11F
6A Jianguomenwai Avenue Chaoyang District
Beijing 100022, PR China
Tel.: +86 10 6563 9000

4526 Research Forest Drive,
Suite 400
The Woodlands
Texas 77381, U.S.A.
Tel.: +1 936 271 6500

Xomox International GmbH & Co. OHG
Von-Behring-Str. 15
88131 Lindau, Germany
Tel.: +49 8382 702 0

ARMATURE d.o.o.
Koroška cesta 55
2366 Muta, Slovenia
Tel.: +386 2 877 05 00

Crane Ningjin Valve Co., Ltd.
No. 496 Jing Long Street
Ningjin County
Hebei Province 055550, PR China
Tel.: +86 319 5808686

Crane Company, and its subsidiaries cannot accept responsibility for possible errors in catalogues, brochures, other printed materials, and website information. Crane Company reserves the right to alter its products without notice, including products already on order provided that such alteration can be made without changes being necessary in specifications already agreed. All trademarks in this material are the property of the Crane Company or its subsidiaries. The Crane and Crane brands logotype (ALOYCO[®], BAUM[®], CENTER LINE[®], CRANE[®], CRYOFLO[®], DEPA[®] & ELRO[®], DOPAK[®], DUO-CHEK[®], FLOWSEAL[®], GYROLOK[®], GO REGULATOR[®], HOKE[®], JENKINS[®], KROMBACH[®], NOZ-CHEK[®], PACIFIC VALVES[®], RESISTOFLEX[®], REVO[®], SAUNDERS[®], STOCKHAM[®], TEXAS SAMPLING[®], WESTLOCK CONTROLS[®], WTA[®], and XOMOX[®]) are registered trademarks of Crane Co. All rights reserved.