



brands you trust.



High Performance Butterfly Valves



Crane ChemPharma & Energy

[www.cranecpe.com](http://www.cranecpe.com)



## Key Features & Applications



Flowseal is a leading provider of soft seat, metal seat and fire-safe high performance butterfly valves. Our products are manufactured under an ISO 9001 Quality Assurance Program that assures each valve we produce meets or exceeds your application requirements.

Additionally, our Design and Manufacturing facility is certified to the Pressure Equipment Directive (PED), and Flowseal valves can be ordered as CE marked.

Flowseal high performance butterfly valves are a standard in many industries including heating, ventilating and air conditioning, power generation, hydrocarbon processing, water and waste water treatment, and marine and commercial shipbuilding. Our products are also installed in applications as diverse as food and beverage processing, snowmaking and pulp and paper production. Configurations are available for harsh conditions as well as applications requiring nominal pressure and temperature ratings.

As part of Crane Valve Group, Flowseal high performance butterfly valves are backed by the resources and experience of one of the world's largest valve producers with a delivery and quality track record that is unparalleled in the industries we serve.

### Key Features & Benefits

- 1 High performance shutoff and modulating service for standard industrial process lines
- 2 Materials of construction options include Carbon and Stainless Steels
- 3 Sizes up to 48", both wafer and lugged body styles available, classes 150 – 600

### Typical Applications

- Hydrocarbon Processing
- Chemical/Petrochemical Processing
- Marine and Commercial Shipbuilding
- Power and Utilities
- Pulp and Paper

NOTE: In keeping with our policy of continuing improvement, we reserve the right to institute changes in design, material, dimensions, or specifications without notice and without incurring any obligation to make such changes and modifications on product previously or subsequently sold.

\* For valves supplied with a chainwheel, the positive restraint option is recommended.

## Unique Valve Seat Design **Soft Seat**

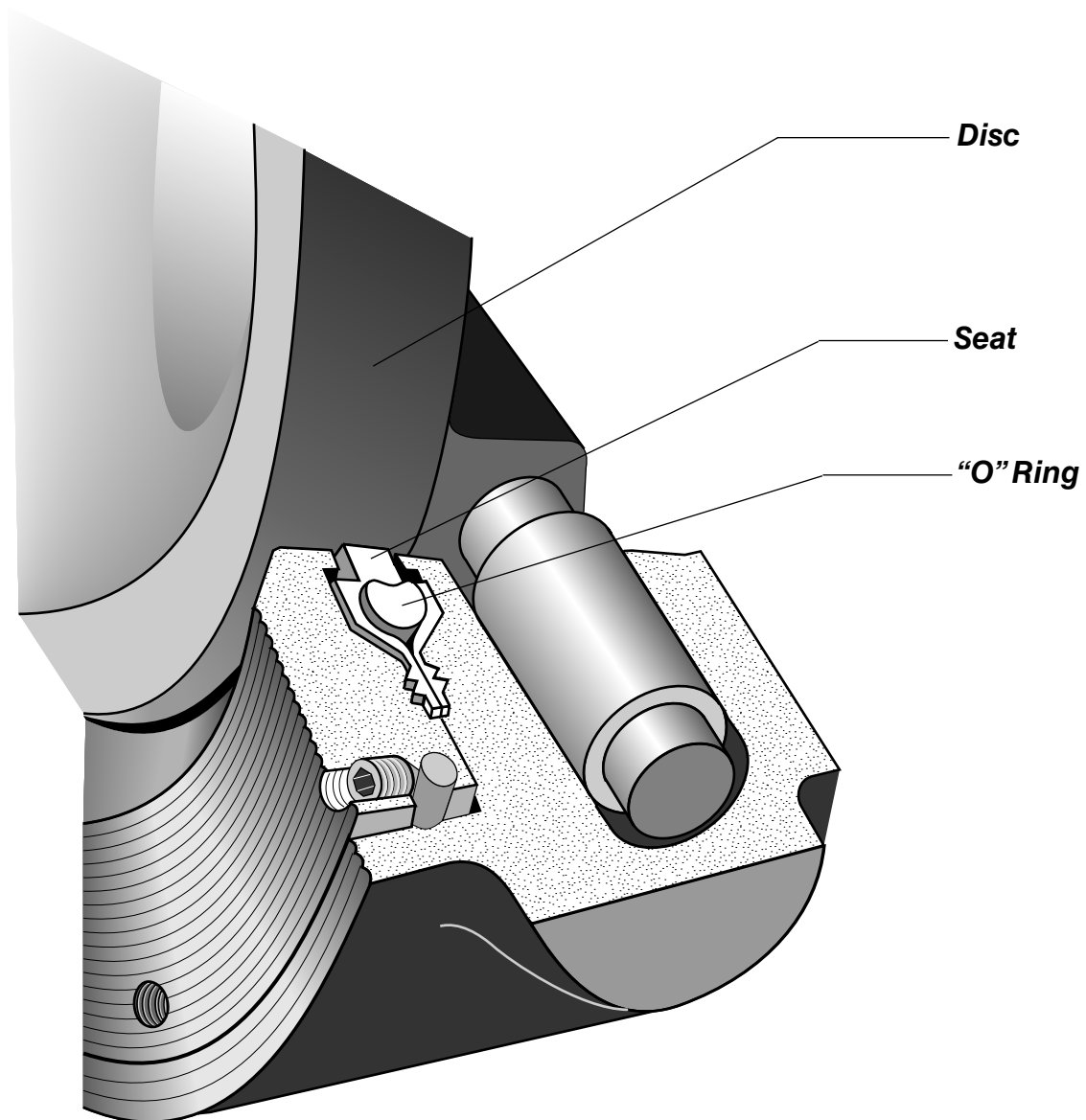

Flowseal is one of the world's leading manufacturers of high performance butterfly valves. Based on many years of research, development, and field experience, the Flowseal design is superior to, and more versatile than, the High Performance Butterfly Valve design offered by other manufacturers.

The Flowseal soft seat valve provides a bi-directional bubble tight shutoff (zero leakage) by the use of a patented seat. This unique seat design creates a self-energized seal in vacuum-to-low pressure applications.

Under higher pressure conditions, the seat is also designed to permit, confine, and direct movement of the soft seat against the disc edge, up to the full ASME Class 150, 300 and 600 Cold Working Pressures.

The soft seat is designed for high services with minimal wear and low torque. Seat replacement is a simple operation, requiring no special tools.

# Principle of Seat Sealing **Soft Seat**

## DISC OPEN

In Figure 1, the disc and seat are not engaged. In this position, the shoulders of the seat are forced against the cavity shoulders by the compression of the o-ring.

The seat is recessed inside the seat cavity and acts as a gasket in the anchoring groove area. The seat cavity is sealed from exposure from the process fluid and protects the seat from abrasion and wear. The o-ring, which is completely encapsulated by the seat, is also isolated from exposure to the process fluid.

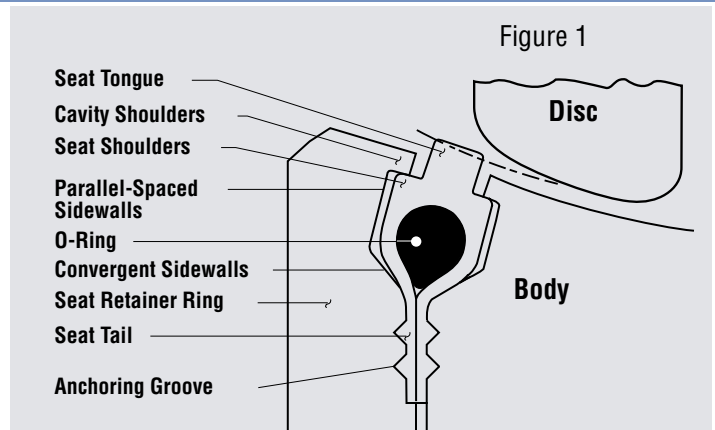

## DISC CLOSED, Self-Energized Seal

In Figure 2, the Flowseal disc and seat are engaged, and the process fluid is under low pressure. The edge of the disc, with a larger diameter than the seat tongue, directs movement of the seat radially outward, causing the seat to compress against the convergent sidewalls of the cavity. The elastomeric o-ring imparts a mechanical pre-load between the disc and seat tongue as it is compressed and flattened by the disc; this is the self-energized mode for sealing at vacuum-to-60 psig.

As the seat moves radially outward, the seat shoulders move away from the cavity shoulders and open the cavity to the process media.

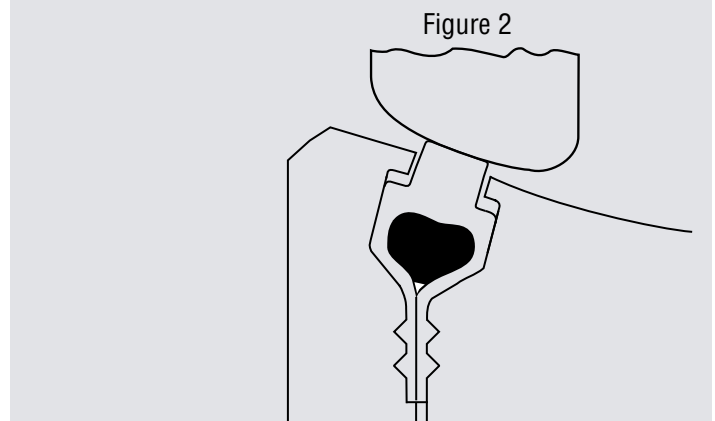

## DISC CLOSED, Pressure-Energized Seal (Seat Upstream)

As line pressure increases, the process fluid enters the sidewall area and applies a load against the parallel-spaced sidewall and convergent sidewall of the seat. The seat and cavity design permits the seat to move axially to the downstream sidewall, but confines the movement and directs the movement radially inward towards the disc; the higher the line pressure, the tighter the seal between the disc and seat. Because the o-ring is elastic, it is able to flex and deform under loads and return to original shape after removal of the load; it is the rubber which deforms, not the thermoplastic material.

This dynamic seal, patented by Flowseal, is totally unique among high performance butterfly valves.

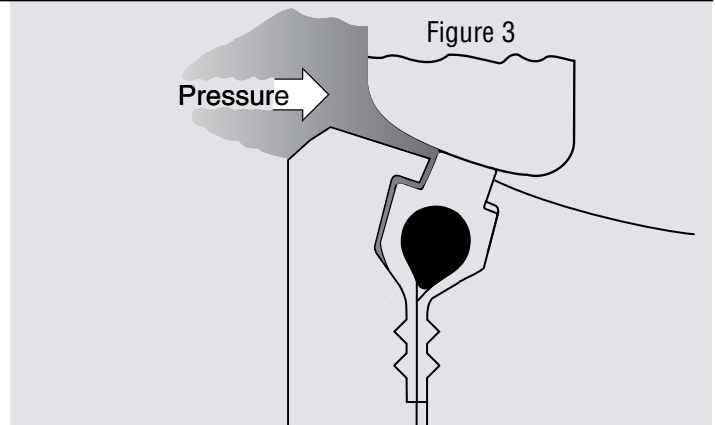

## DISC CLOSED, Pressure-Energized Seal (Seat Downstream)

The Flowseal valve is bi-directional (in some instances, modifications may be required to operate this arrangement for dead end service). The cavity and seat sidewalls are symmetrically designed to permit, confine, and direct movement of the seat to the disc to dynamically seal with line pressure in the reverse direction. The disc edge is the segment of a sphere, and the seat is angled towards the disc edge to seal with pipeline pressure in either direction.

Recommended installation direction is "SUS" (seat upstream), as in Figure 3.

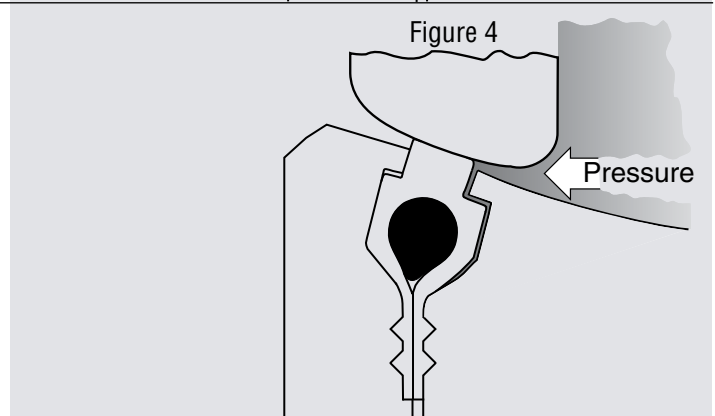

# Valve Components Soft Seat

**KEY**

Square key valve-to-operator connection provides an externally controlled failure point upon over-torquing.

**GLAND FLANGE**

Applies load against packing gland to prevent external leakage. Fully adjustable.

**PACKING**

Chevron design TFE prevents external leakage out valve neck to full ASME hydrostatic shell test pressures (150% of C.W.P.).

**WEDGE RING**

Stainless steel band wedged between valve body and retainer ring by set screws to lock seat and retainer ring in position on valve sizes 2" through 30". Socket head cap screws are used on valve sizes 36" and larger.

**SET SCREWS**

Cone point screws force wedge ring outward to lock seat retainer in position on valve sizes 2" through 30" wafer. Socket head cap screws are used on valve sizes 36" and larger and all DDES lug valves.

**OVERTRAVEL STOP**

Prevents disc from rotating into the wrong quadrant.

**SOFT-SEAT**

Patented bi-directional seat with encapsulated elastomeric o-ring core for resiliency. Common seat materials include TFE, RTFE and UHMWPE.

**BLOW OUT PROOF SHAFT**

Solid shaft provides alignment and rigid support for disc.

**PACKING GLAND**

Separate part from gland flange, preventing uneven load distribution against packing.

**BEARINGS**

Both above and below the disc, bearings are of composite design: PTFE bonded to epoxy-glass filament wound ring. Used to align shaft, with high capacity, low wear, and low friction coefficient.

**DISC SPACERS**

Disc is centered by use of thrust spacers around shaft in sizes 2" to 5". Disc position stops or thrust bolt arrangements are used for larger valve sizes.

**WEDGE PINS**

Provide positive mechanical attachment of disc to shaft.

**BODY**

ASME B16.34 design in either wafer or lug configuration.

**DISC**

360° uninterrupted spherical edge for sealing. Profile is designed for maximum flow and equal percentage control.

**RETAINER RING**

Retains seat in valve. Standard surface finish is 125 to 200 AARH and is compatible with both standard gaskets and spiral wound gasket designs. Outside diameter is recessed within gasket sealing surface to prevent external leakage.

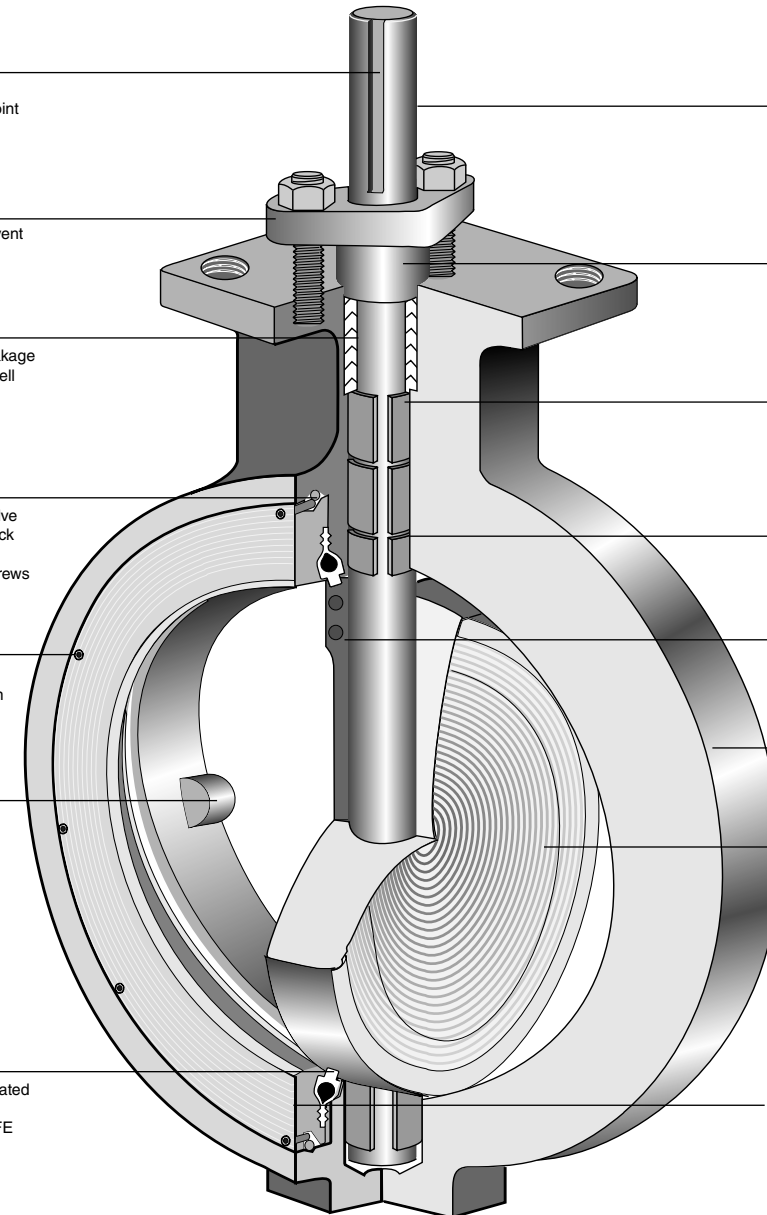

## End Seal Variation

The ASME 150 14" through 30" sizes feature a two-piece shaft design. The lower shaft utilizes an end seal in the body to prevent external leakage.

The component parts include an end seal, an end cap and end cap bolts.

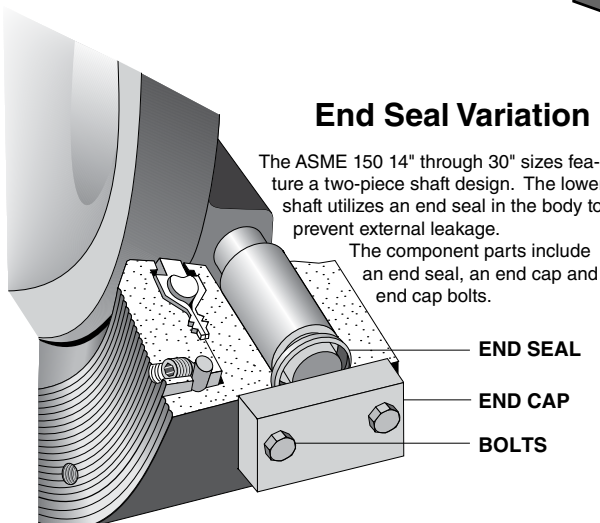

- END SEAL
- END CAP
- BOLTS

## Lower Packing Variation

The ASME 150 14" through 48"; ASME 300 14" through 30"; ASME 600 10" through 16" sizes feature a two-piece shaft design which utilizes a lower packing seal in the valve body to prevent external leakage.

The component parts are of the same design used in the packing assembly in the top of the valve body neck.

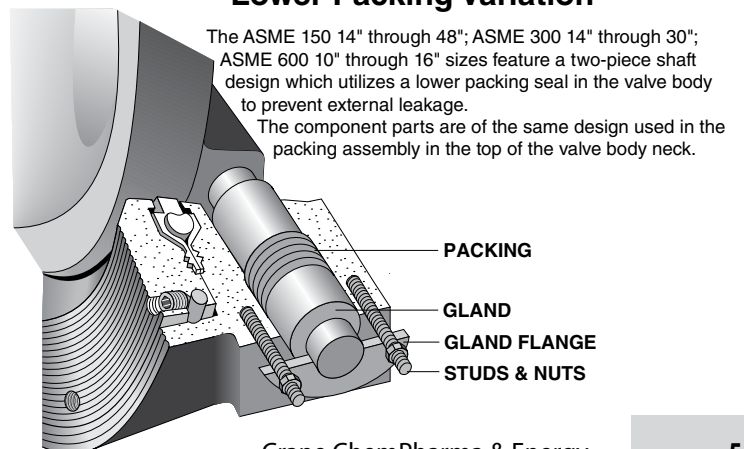

- PACKING
- GLAND
- GLAND FLANGE
- STUDS & NUTS



## Unique Valve Seat Design **Metal Seat**

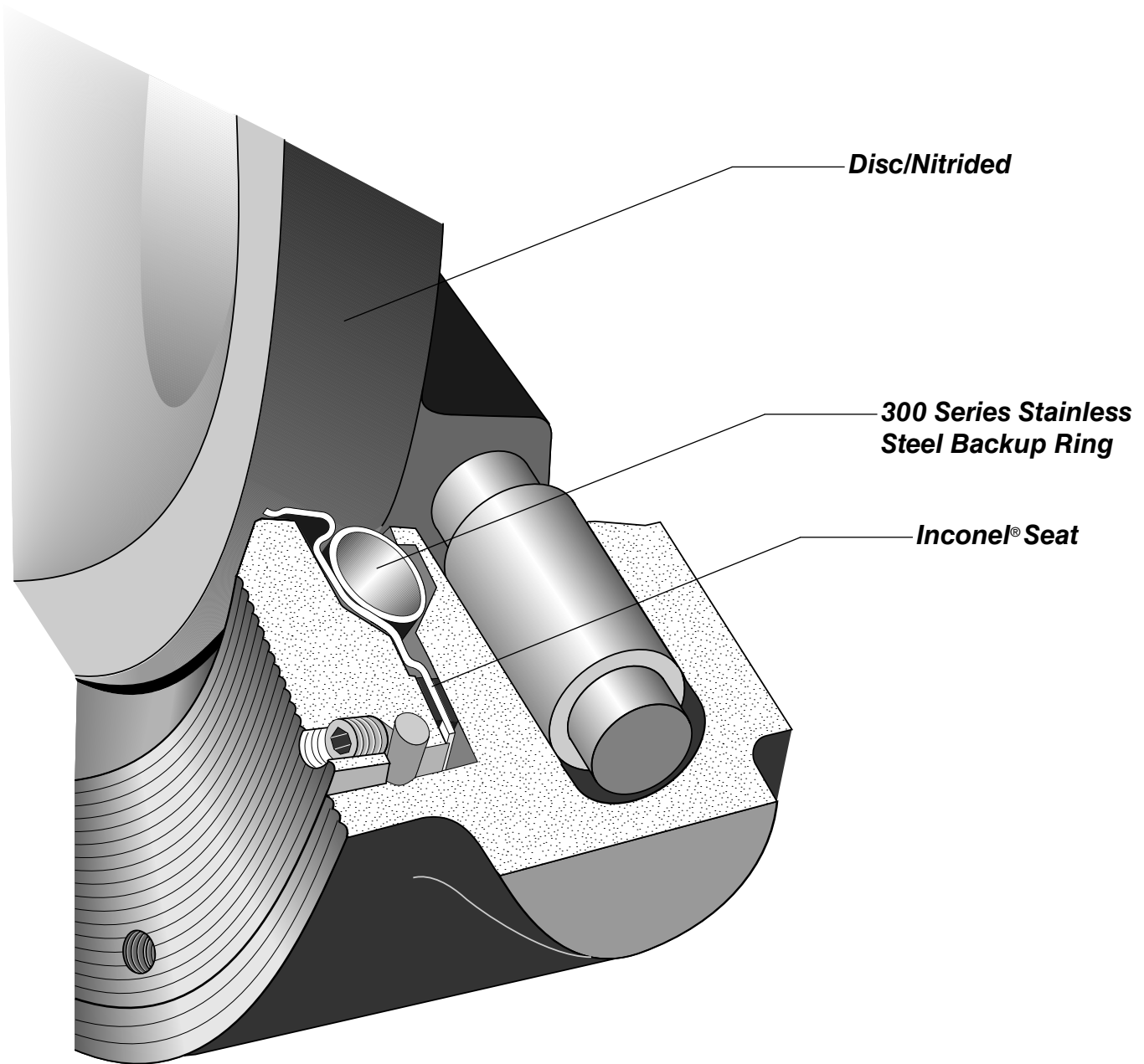

The Flowseal metal-to-metal seat high performance butterfly valve incorporates an Inconel® seat for higher tensile strength, a 300 series stainless steel back-up ring in the seat cavity for axial seat support, and a disc that is case hardened by nitriding.

The Inconel® seat, by its dynamic and flexible design, applies enough force per linear inch against the disc edge

(Rockwell Hardness of C66 to C70) to obtain an optimum sealing characteristic while controlling the loads between the metal surfaces.

The Flowseal metal-to-metal seat valve is utilized for temperatures up to 900°F (482°C) in compliance with ASME B16.34 pressure/temperature specifications. Leakage is rated at Class IV per ASME FCI 70-2.

Inconel® is a registered trademark of Special Metals Corporation.

# Principle of Seat Sealing Metal Seat

## PRINCIPLE OF METAL SEATING

Metal-to-metal sealing is accomplished by the “line contact” between a spherical surface and conical surface. Figure 1 illustrates a typical globe control valve seat and plug. The plug seating surface is the segment of a sphere; when engaged against the seat ring, a line contact seal is achieved.

In a metal seat design, it is necessary to apply enough force per linear inch to maintain a tight metal-to-metal contact between the sealing members; however, high linear thrust can cause a collapse of the seating members (“bearing failure”).

Figure 1

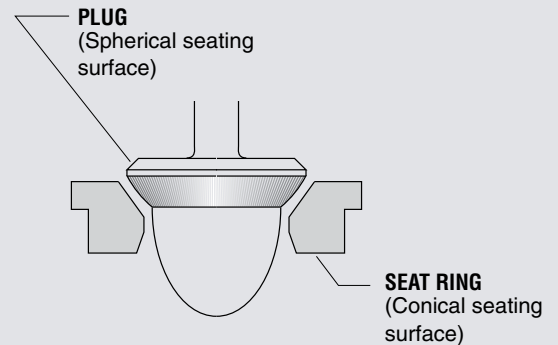

## DISC CLOSED, Self-Energized Seal

In Figure 2, the Flowseal disc and seat are engaged, and the process fluid is under low pressure. The spherical edge of the disc, with a larger diameter than the conical seat tongue, imparts a thrust of approximately 600 pounds per linear inch against the seat. The mechanical properties and shape of the Inconel® seat allow it to both flex and maintain a constant thrust against the disc.

This controlled loading prevents the occurrence of bearing failure and reduces the leakage and wear between the components.

Figure 2

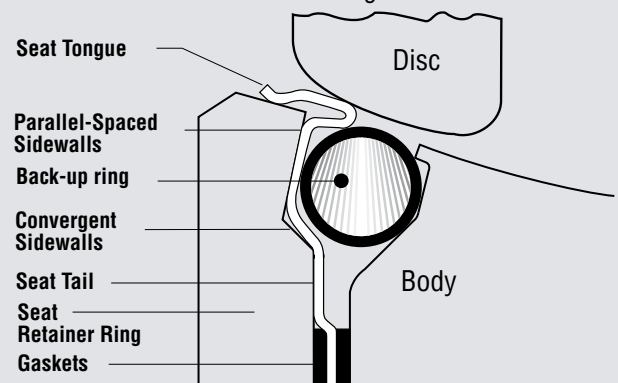

## DISC CLOSED, Pressure-Energized Seal (Seat Upstream)

As line pressure increases, the process fluid enters the sidewall area and applies a load against the parallel-spaced sidewall and convergent sidewall of the metal seat. The seat moves towards the downstream sidewall while being supported axially by the support ring, as shown in Figure 3. The cavity shape confines the seat movement and directs the movement radially inward towards the disc; the higher the line pressure, the tighter the line contact between the disc and seat. The Inconel® seat, shaped by a special hydroforming process, is able to flex under these loads and return to its original shape after removal of the loads.

This dynamic seal, patented by Flowseal, is totally unique among high performance butterfly valves.

Figure 3

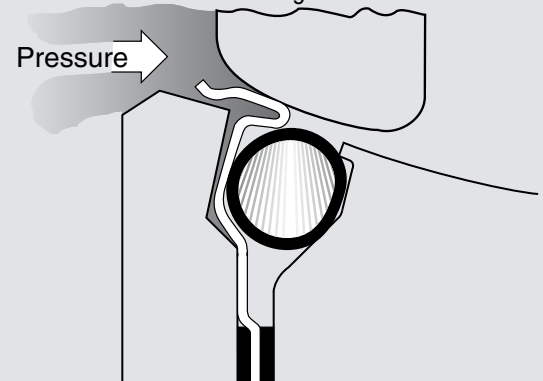

## DISC CLOSED, Pressure-Energized Seal (Seat Downstream)

The Flowseal valve is bi-directional (in some instances, modifications may be required to operate this arrangement for dead end service). The cavity and seat sidewalls are symmetrically designed to permit, confine, and direct movement of the seat to the disc to dynamically seal with line pressure in the seat downstream direction, as in Figure 4. Recommended installation direction is “SUS” (seat upstream), as in Figure 3.

The stainless steel back-up ring interacts dynamically with the metal seat for axial support in seat sealing. Additionally, this ring effectively restricts corrosion and particulate build-up in the cavity.

Figure 4

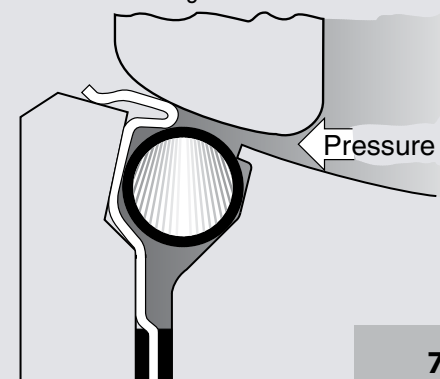

# Valve Components Metal Seat

**KEY**  
Square key valve-to-operator connection provides an externally controlled failure point upon over-torquing.

**GLAND FLANGE**  
Applies load against packing gland to prevent external leakage. Fully adjustable.

**PACKING**  
Common materials are TFE for up to 450°F (232°C) and Graphite for up to 900°F (482°C).

**WEDGE RING**  
Stainless steel band wedged between valve body and retainer ring by set screws to lock seat and retainer ring in position on valve sizes 2" through 30". Socket head cap screws are used on valve sizes 36" and larger.

**WEDGE PINS**  
Provide positive mechanical attachment of disc to shaft.

**OVERTRAVEL STOP**  
Prevents disc from rotating into wrong quadrant.

**SET SCREWS**  
Cone point screws force wedge ring outward to lock seat retainer in position on valve sizes 2" through 30". Socket head cap screws are used on valve sizes 36" and larger.

**METAL SEAT**  
Patented metal seat with metal back-up ring.

**SHAFT**  
Solid shaft provides alignment and rigid support for disc.

**PACKING GLAND**  
Separate part from gland flange, preventing uneven load distribution against packing.

**BEARINGS**  
Both above and below the disc, bearings maintain shaft alignment. Common materials include:

- Glass-backed TFE for up to 450°F (232°C). (Not for steam service.)
- Luberized Bronze for up to 750°F (398°C).
- 300 Series Stainless Steel Nitrided for up to 900°F (482°C).

**DISC SPACERS**  
Disc is centered by use of thrust spacers around shaft in sizes 2" to 5". Disc position stops or thrust bolt arrangements are used for larger sizes.

**BODY**  
ASME B16.34 design in either wafer or lug configuration.

**DISC**  
360° uninterrupted spherical edge for sealing. Profile is designed for maximum flow and equal percentage control. Disc seating surface is Nitrided for enhanced temperature and abrasion resistance.

**RETAINER RING**  
Retains seat in valve. Standard surface finish is 125 to 250 AARH and is compatible with both standard gaskets and spiral wound gasket designs. Outside diameter is recessed within gasket sealing surface to prevent external leakage.

## End Seal Variation

The ASME 150 14" through 24" sizes feature a two-piece shaft design. The lower shaft utilizes an end seal in the body to prevent external leakage. The component parts include an end seal, an end cap and end cap bolts.

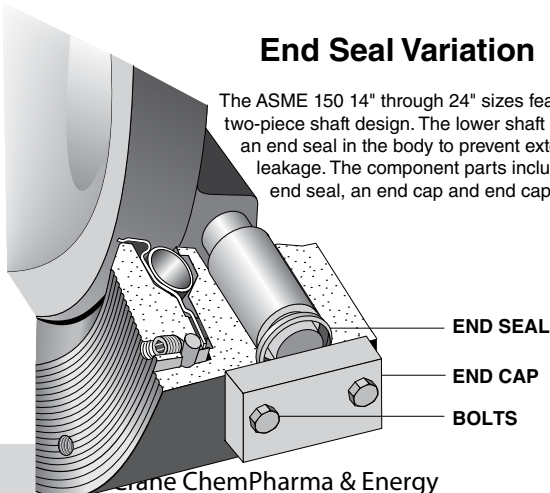

## Lower Packing Variation

The ASME 150 30" through 48"; ASME 300 14" through 30"; ASME 600 10" through 16" sizes feature a two-piece shaft design which utilizes a lower packing seal in the valve body to prevent external leakage. The component parts are of the same design used in the packing assembly in the top of the valve body neck.

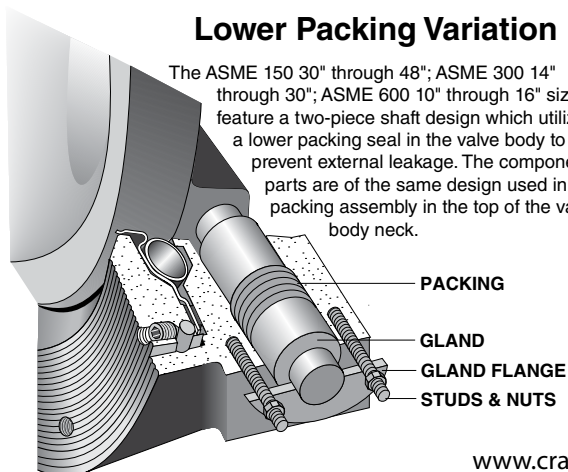



## Unique Valve Seat Design Fire Flow

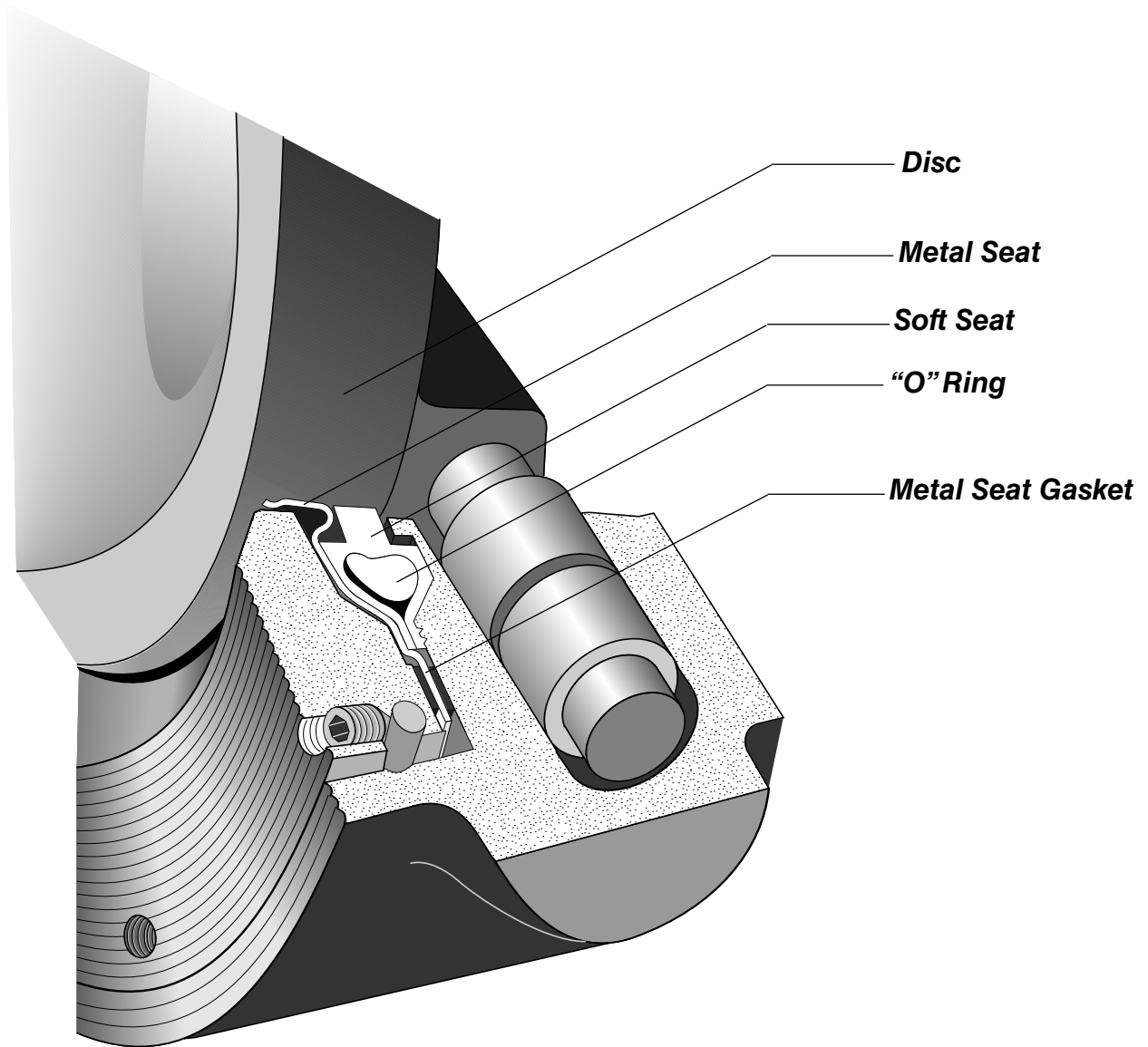

The Flowseal Fire-Flow™ high performance butterfly valve (HPBV) is a fire-safe, soft seat quarter-turn valve. The Fire-Flow™ design incorporates two patented seats which function together to seal off pipeline flow. In normal operation, the soft seat provides a bi-directional “bubble tight” shutoff (zero leakage); the metal seat provides bi-directional shutoff in the event of a fire, in conformance to industry fire-safe requirements.

With little or no pressure, the Fire-Flow seat creates a self-energized seal against the disc. Higher line pressures act on

the geometry of both seats to dynamically load them against the disc, creating higher sealing forces in either direction.

The Fire-Flow™ metal seat is made of Inconel® material which is shaped by a proprietary hydroforming process into its unique, patented design. Stainless steel outer bearings are included for post-fire disc and shaft alignment. Fireproof packing is used to prevent external shaft leakage.

# Principle of Seat Sealing Fire Flow

## DISC OPEN, Normal Operation

In Figure 1, the disc and seat assembly are not engaged. In this position, the metal seat acts to keep the soft seat inside the seat cavity while the soft seat shoulders seal the cavity from exposure to the process fluid. (The o-ring is under tension and imparts a load against the soft seat.)

The soft seat is protected from abrasion and wear because it is recessed inside the seat cavity area. The o-ring is isolated from exposure to the fluid because it is completely encapsulated by the seat tails which act as a (soft) gasket in the anchoring groove area. The metal seat gaskets add further high temperature protection past the anchoring grooves.

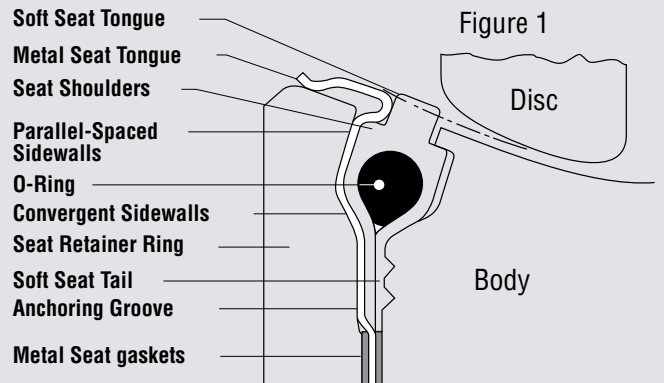

## DISC CLOSED, Normal Operation

In Figure 2, the disc and seat assembly are engaged; both the metal seat and the soft seat are in contact with the disc. Under little to no pressure conditions, both seats are self-energized. The disc edge, with a larger diameter than the seat tongues, moves the seats radially outward; the metal seat shape, with a mechanical and dynamic flexibility, is designed to be hoop-loaded and impart a spring force against the disc, while the soft seat o-ring is stretched and flattened (without deformation of the material) and imparts a mechanical pre-load against the disc.

With increased line pressure, the process fluid enters the cavity sidewall area and applies loads against the seat sidewalls. The cavity design allows the seats to move toward the downstream sidewalls, but confines and directs the movement radially inward towards the disc; the higher the pressure the tighter the seal. The symmetrical shape and angle of the cavity permit the seal to be bi-directional.

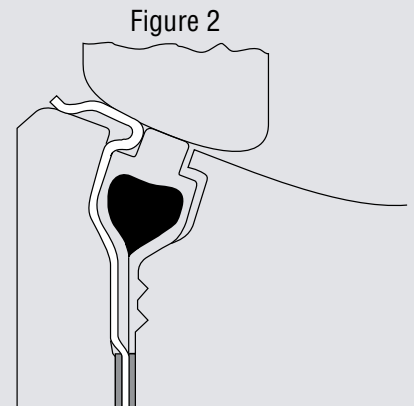

## DISC CLOSED, After Fire (Seat Upstream)

After a fire, with partial or complete destruction of the soft seat, the metal seat maintains metal-to-metal contact with the disc and restricts leakage of the process fluid in conformance to industry fire-safe requirements.

With little or no line pressure, the spring force and hoop load of the metal seat maintain a "line contact" seal against the disc edge. Under higher pressures, the process fluid enters the cavity sidewall areas and applies loads against the seat sidewalls (Figure 3). The geometry of the metal seat permits the seat to move axially, but directs the movement radially inward toward the disc. The higher the pressure, the tighter the line contact seal.

Graphite gaskets, on both sides of the metal seat tail, seal the anchoring groove and prevent leakage of the process fluid.

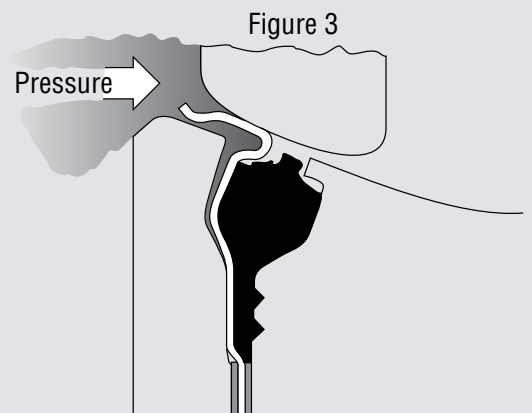

## DISC CLOSED, After Fire (Seat Downstream)

The Flowseal Fire-Flow™ valve is bi-directional; however, modifications are required to operate for bi-directional dead end service. The angle and shape of the cavity and metal seat maintains metal-to-metal contact in the event of partial or complete soft seat destruction with line pressure in the reverse direction (Figure 4).

While the preferred flow direction is "seat upstream" (SUS), the bi-directional seat design is both self-energized and pressure-energized if the flow direction is "seat downstream" (SDS).

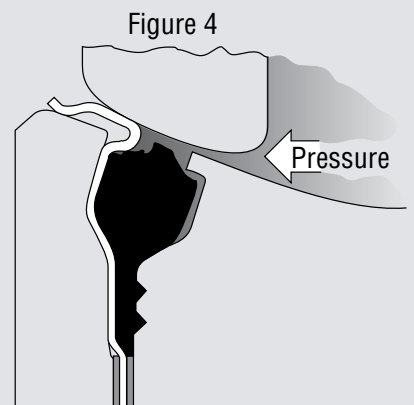

# Valve Components Fire Flow

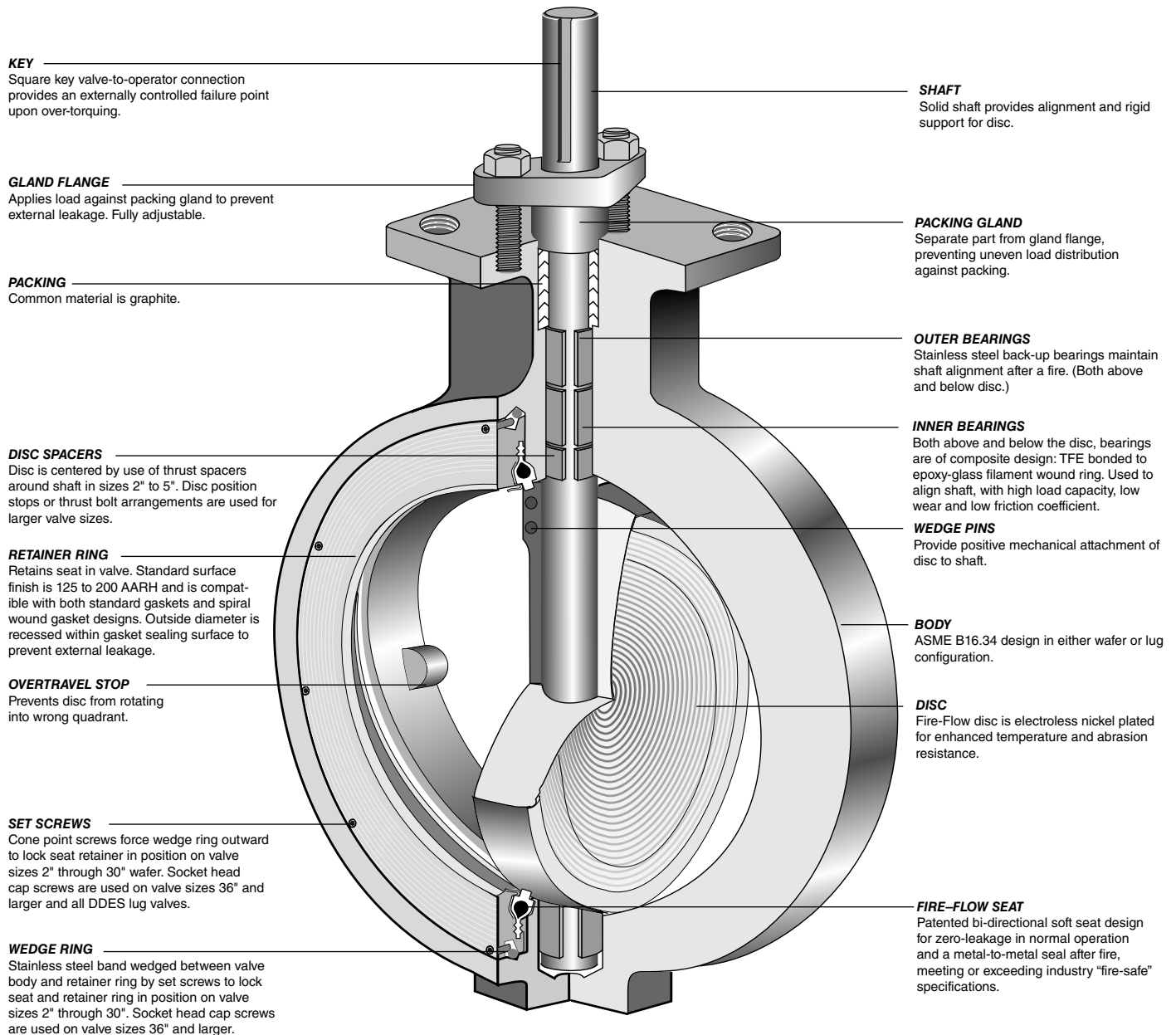

## End Seal Variation

The ASME 150 14" through 24" sizes feature a two-piece shaft design. The lower shaft utilizes an end seal in the body to prevent external leakage. The component parts include an end seal, an end cap and end cap bolts.

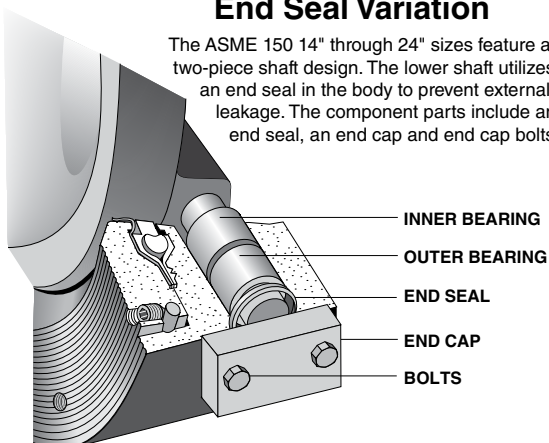

## Lower Packing Variation

The ASME 150 30" through 48"; ASME 300 14" through 30"; ASME 600 10" through 16" sizes feature a two-piece shaft design which utilizes a lower packing seal in the valve body to prevent external leakage. The component parts are of the same design used in the packing assembly in the top of the valve body neck.

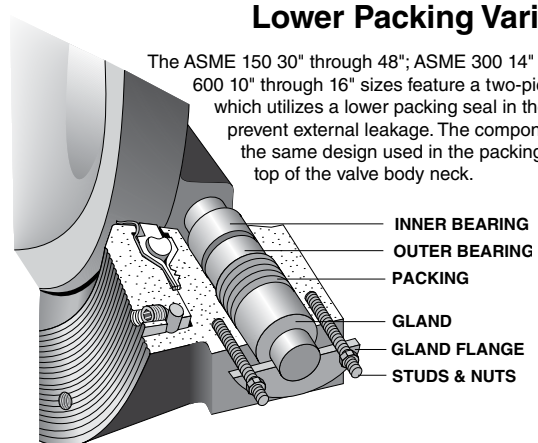

# Actuators

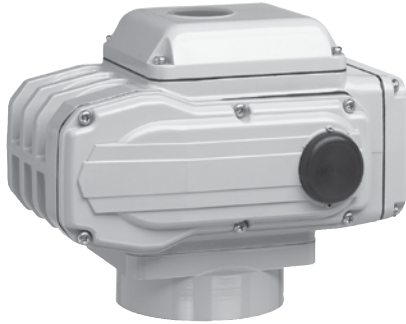

## ELECTRIC-ON-OFF

### Standard Features:

Torque Range— 347 lb ins to 17,359 lb ins  
 Housing— NEMA4 & 4X  
 Electric Motor—120VAC, 1 PHASE, 60Hz  
 Thermal Overload—Auto re-set  
 Limit Switches— Adjustable cam operated  
 Position Indicator—Mechanical Dial Type  
 Space Heater—Located in the control compartment  
 Terminal Strip— Pre-wired for motor & limit switches  
 Manual Override—Directing acting  
 Brake—“Lock-cut” gear arrangement  
 Adjustable Mechanical Travel Stops  
 Temperature Range—-13°F to 131°F (-25°C to 55°C)  
 Mounting— Direct mount to Center Line valves  
 Certification/Approvals—CSA-NRTL/C

### Optional Features:

AC Voltages— 220VAC, 1 PHASE, 60 Hz  
 AC Voltages— 24 VAC 44005-44400  
 DC Voltages— 12/24 VDC 4005-44300  
 Additional Limit Switches—2 SPDT  
 Torque Switches—Adjustable open and close  
 Feedback Potentiometer— 500 ohm  
 Feedback Transmitter—4-20 mA  
 De-clutchable Handwheel Override

## ELECTRIC-MODULATING

### Standard Features:

Process Control Signal—4-20 mA, 0-10 V DC  
 Torque Range—347 lb ins to 17,359 lb ins  
 Housing— NEMA4 & 4X  
 Electric Motor—120VAC, 1 PHASE, 60 Hz  
 Thermal Overload—Auto re-set  
 Resolution—400 increments through 90 degrees  
 Position Indicator— Mechanical Dial Type  
 Space Heater—Located in the control compartment  
 Terminal Strip— Pre-wired for motor & limit switches  
 Manual Override— Directing acting  
 Brake—“Lock-cut” gear arrangement  
 Adjustable Mechanical Travel Stops  
 Temperature Range—-13°F to 131°F (-25°C to 55°C)  
 Mounting— Direct mount to Center Line valves  
 Certification/Approvals—CSA-NRTL/C

### Optional Features

AC Voltages— 220VAC, 1 PHASE, 60 Hz  
 AC Voltages— 24 VAC 44010M- 44200M  
 Torque Switches— Adjustable open and close  
 De-clutchable Handwheel Override

Crane ChemPharma & Energy

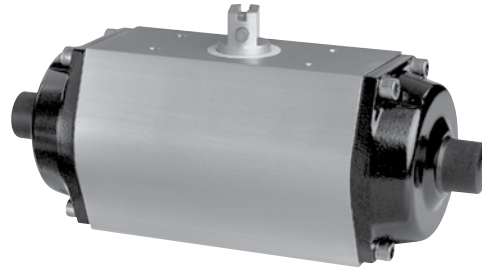

## PNEUMATIC-DOUBLE ACTING

### Standard Features:

Torque Range—80 lb ins to 60,623 lb ins  
 Housing— Castalloy aluminum, polyurethane coated  
 Mounting— ISO5211  
 Top and Solenoid Mounting Pad— NAMUR  
 Position Indicator— Mechanical “Cap” Type  
 Operating Pressure— 20 to 120 PSIG  
 Temperature Range— 4°F to 175°F (-15°C to 79°C)  
 Size Range— 12 models to choose from  
 Adjustable Travel Stops— Both directions  
 Mounting— Direct mount to Center Line valves

### Optional Features:

Temperature Range— 4°F to 250°F, -40°F to 175°F  
 (-15°C to 121°C, -40°C to 79°C)  
 Solenoid Valves— 3 or 4 way  
 Limit Switches— Adjustable cam operated  
 Positioners— Pneumatic or Electro-pneumatic  
 DC-1 Dribble Control— Two-stage shutoff  
 180° Actuation— 2 or 3 position  
 Manual Override— De-clutchable gear type  
 Speed Controls— Adjust cycle time  
 Special Applications— Offshore, nuclear, hygienic,  
 and gas or oil operation

## PNEUMATIC-SPRING RETURN

### Standard Features:

Torque Range—80 lb ins to 41,341 lb ins  
 Housing— Castalloy aluminum, polyurethane coated  
 Mounting— ISO5211  
 Top and Solenoid Mounting Pad— NAMUR  
 Position Indicator— Mechanical “Cap” Type  
 Operating Pressure— 20 to 120 PSIG  
 Temperature Range— 4°F to 175°F (-15°C to 79°C)  
 Size Range— 12 models to choose from  
 Adjustable Travel Stops— Both directions  
 Mounting— Direct mount to Center Line valves

### Optional Features

Temperature Range— 4°F to 250°F, -40°F to 175°F  
 (-15°C to 121°C, -40°C to 79°C)  
 Solenoid Valves— 3 or 4 way  
 Limit Switches— Adjustable cam operated  
 Positioners— Pneumatic or Electro-pneumatic  
 DC-1 Dribble Control— Two-stage shutoff  
 180° Actuation— 2 or 3 position  
 Manual Override— De-clutchable gear type  
 Speed Controls— Adjust cycle time  
 Special Applications— Offshore, nuclear, hygienic,  
 and gas or oil operation











Crane ChemPharma & Energy

CRANE Energy Global Headquarters  
4526 Research Forest Drive, Suite 400  
The Woodlands, Texas 77381 U.S.A.  
Tel.: (1) 936-271-6500  
Fax.: (1) 936-271-6510

Flowseal Customer Service  
9860 Johnson Road  
Montgomery, Texas 77316  
Tel.: (1) 936-588-8380  
Fax.: (1) 936-588-8381

www.cranecpe.com



Sydney, Australia, Operations  
146-154 Dunheved Circuit  
St. Mary's, N.S.W. 2760 Australia  
Tel.: + 61 (2) 9623-0234  
Fax.: + 61 (2) 9673-3870

Düsseldorf, GmbH, Operations  
Crane Process Flow Technology, GmbH  
Heerdter Lohweg 63-71, D-40549  
Düsseldorf, Germany  
Tel.: +49 211-59-56-0  
Fax.: +49 211-59-56-111

**brands you trust.**



**COMPAC-NOZ**



**DEPA**

**ELRO** **DUO-CHEK**



**NOZ-CHEK**



**RESISTOFLEX**



**Saunders**  
*the science inside*

**STOCKHAM**



**UNI-CHEK**

**w.ta.**

**XOMOX**

Crane Co., and its subsidiaries cannot accept responsibility for possible errors in catalogues, brochures, other printed materials, and website information. Crane Co. reserves the right to alter its products without notice, including products already on order provided that such alteration can be made without changes being necessary in specifications already agreed. All trademarks in this material are property of the Crane Co. or its subsidiaries. The Crane and Crane brands logotype, in alphabetical order, (ALOYCO®, CENTER LINE®, COMPAC-NOZ®, CRANE®, DEPA®, DUO-CHEK®, ELRO®, FLOWSEAL®, JENKINS®, KROMBACH®, NOZ-CHEK®, PACIFIC VALVES®, RESISTOFLEX®, REVO®, SAUNDERS®, STOCKHAM®, TRIANGLE®, UNI-CHEK®, WTA®, and XOMOX®) are registered trademarks of Crane Co. All rights reserved.