

DUO-CHEK[®]



THE ORIGINAL DUAL PLATE CHECK VALVE

**DUO-CHEK[®] High Performance
Non-Slam Check Valves**

CRANE[®]

v in www.cranecpe.com

DUO-CHEK® High Performance Non-Slam Check Valves

DUO-CHEK® high performance non-slam check valves are the original Mission Manufacturing Company wafer check valves introduced to the market in the late 1950's. The valves are available in sizes, pressure classes and configurations required to meet the most demanding of applications. Product range includes, but is not limited to:

- Sizes: 2" to 88"
- ASME B16.34 & API 6D, pressure classes 150 – 4500
- API 6A pressure rating 2000 – 15,000
- DIN, JIS, BS, AS, and ISO standards are also available
- Wafer, lug, double flanged and extended body styles

Note: Consult factory for special application requirements

- Cast Iron, Carbon Steel, Stainless Steels,
- Duplex Stainless Steel, Super Duplex
- High Alloy materials, Inconel® 625, Titanium, etc.
- Available in Cast and Forged materials as required

Resilient Seat Materials:

- EPDM, Buna-N, Neoprene, FKM-B and Vermillion®
- Integral and overlaid metal seats also available

End Connections:

- Raised Face, Plain Face, Ring Joint,
- Weld-End, Hub-End

Lining and Cladding:

- Internal Rubber Lining e.g Neoprene and FBE
- Internal Cladding e.g. Inconel® 625, Incoloy 825 and Stainless Steel

Typical Body Materials:

Industry Standards*	
API 594	Valve Design
API 598	Valve Pressure Testing and Inspection
ASME B16.5 & B16.47	Flanges
ASME B16.34	Pressure/Temperature Ratings
API 6D	Pipeline Valves
API 6A	Production Valves
2014/68/EU	Pressure Equipment Directive
BS 6364	Cryogenic testing

*Consult factory for other specification requirements.

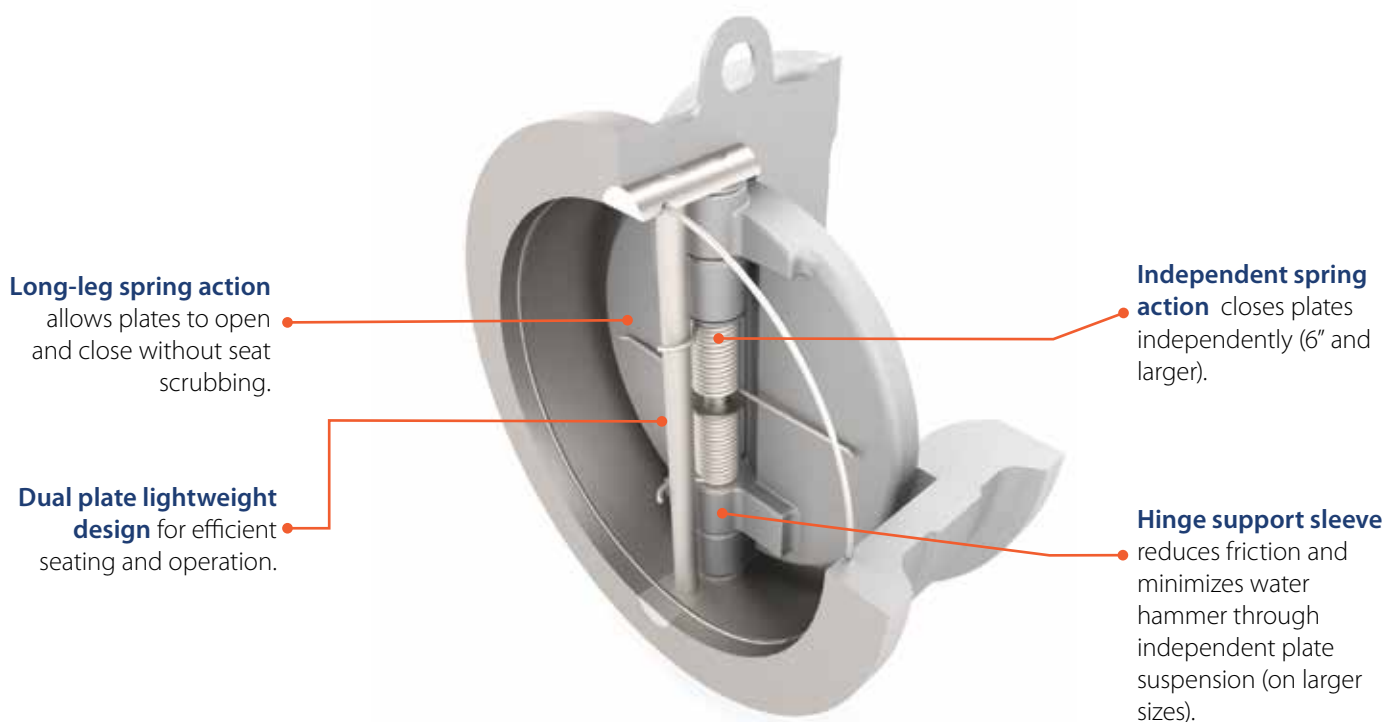

DUO-CHEK® Retainerless

Key Features and Typical Applications

Key Features & Benefits

- ❶ Dual-plate designs are compact and lightweight for efficient seating, operation and lower installation cost
- ❷ Independent springs with long legs to prevent seat scrubbing and provide non-slam performance
- ❸ Retainerless valve design without body penetration for critical service applications



Double Flanged (Retainerless)

Typical Applications

- Petroleum Refining
- Oil and Gas Production
- Chemicals and Petrochemicals
- Power Generation
- Steel/Primary Metals
- Marine
- Water and Wastewater
- Pulp and Paper
- LNG
- FPSO
- Renewables

Features	Benefits
Lightweight and Compact Design	Significant weight saving verses swing checks. Saves space and money in initial valve and installation cost.
Long leg spring design	Plate heel is lifted first by design to prevent seat wear. Employs two spring- loaded plates with flat seats. Gives superior performance to meet industry standards.
Independent Spring Action	Provides improved valve response and longer life. Longer valve life and improved system performance by reducing water hammer.
Independent Plate Suspension	Assurance of non-slam performance with faster valve response.
Variety of Body Designs Available	Lug, Double Flange, Wafer, Weld End, Hub End and Extended body. Provides options to suit application needs.
Wide Variety of Materials	Versatility for many services. Satisfies more application needs.
Body Strength and Rigidity	Provides more rigidity than pipe, eliminating concerns of pipe bending loads of flanged valves.
Flexibility in Installation Position	Suitable for horizontal or vertical up positions. Simplifies piping design, eliminates constraints that swing checks create.
Retainerless DUO-CHEK® Design Eliminates Body Penetrations	For critical service applications, prevents possible escape of unwanted and/or hazardous materials to atmosphere. Ensuring no body penetrations, resulting zero fugitive emissions. Provides safety in critical services by eliminating environmental concerns.
Vertical pin orientation	In horizontal position, flow allows plates to function freely and fully open under lower flow conditions. Reduces pressure loss, improves dynamic response and eliminates valve chatter when compared to swing check.

Specify DUO-CHEK® ...to your Advantage

Leading engineers specify DUO-CHEK® for check valve applications because it provides high performance. Extensive research and testing with demonstrated performance has earned worldwide recognition, unmatched in the industry.

The DUO-CHEK® Wafer valve design is generally stronger, lighter, smaller and more efficient than conventional swing check valves. Its design meets API 594 which is approximately one quarter the face to face dimension and 15% to 20% the weight, on most popular sizes. It is much easier to install between standard gaskets and line flanges. The savings

compound during installation due to ease of handling and only one set of flange studs is required. Therefore, it is more cost effective to install, and also to maintain.

The DUO-CHEK® also offers special design features that make it a high performance non-slam check valve. These include a scrub-free opening, and in most sizes a unique independent spring design as well as an independent plate support system. These features may not be found in other check valves. Other configurations offered include lug, double flange and extended body.



84 inch DUO-CHEK®

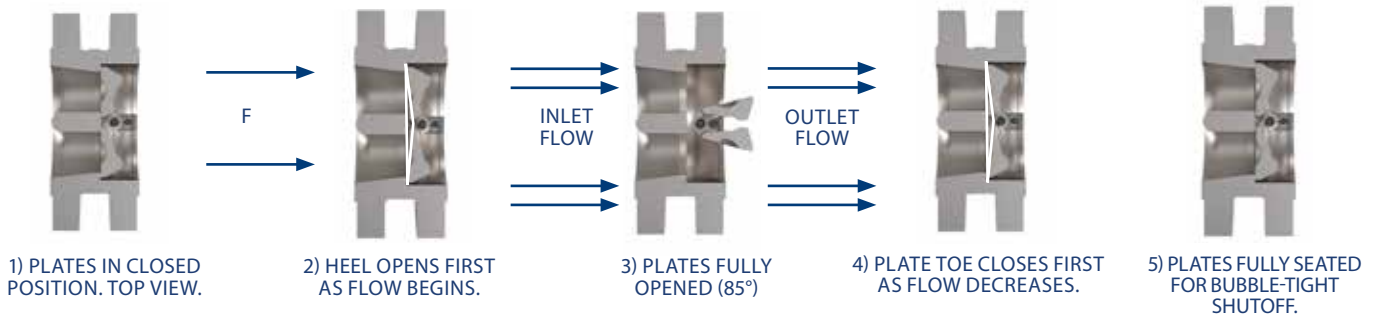

The innovative dual-plate design of the DUO-CHEK® employs two spring-loaded plates (disc halves) suspended on a central vertical hinge pin. As fluid flows from inlet to outlet direction, the pressure difference across the valve creates a force on the plates, causing them to open. The off centre contact point of the spring leg creates a moment/torque across the plate, such that the heel lifts from the seal face first. This prevents rubbing of the seal surface prior to normal plate opening, eliminating wear.

As the velocity of flow decreases, torsion spring action reacts automatically. This moves the plates closer to the body seats, reducing the distance and time of travel for closure. By having the plates closer to the body seats at the time of flow reversal, the valve dynamic response is greatly accelerated. This dramatically reduces the water hammer effect for non-slam performance.

At closing, the point of spring force causes the toe of the plates to close first. This prevents dragging of the heels of the plates and maintains seal integrity for much longer periods.

A spring design of the DUO-CHEK®

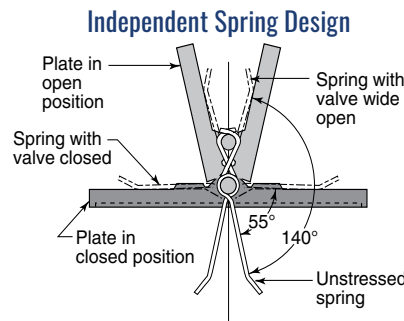

(sizes 6" and larger) allows higher torque to be exerted against each plate with independent closing in response to the process stream. Testing has proved this action provides up to 25% improvement in valve life and 50% reduction in water hammer.

Each of the two plates has its own spring or springs, which provide independent closing action. These independent springs undergo less angular deflection, only 140° as compared to 350° for conventional springs with two legs.

Independent Plate Suspension Design

The DUO-CHEK® unique hinge design reduces friction forces by 66%, which improves valve response significantly. Support sleeves are inserted through hinges so that the upper hinge is independently supported by the lower sleeve during valve operation. This allows both plates to close at the same time for quick response, and excellent dynamic performance.

High Pressure Gas and Cryogenic In-House Testing

Improved Leak Rates for Low Temperature Service

Crane's DUO-CHEK® dual plate check valves can now be offered to meet industry standard leak rate specifications for low temperature and Cryogenic service down to -196°C / -321°F.

The extensive product line can now be offered to meet the stringent requirements of BS 6364, and other standards such as ISO 28921, MSS SP-134 and Shell 77/200.

The DUO-CHEK® Cryogenic range is available in standard cryogenic materials such as 316SS, and in 2"- 72" sizes. Pressure classes are available per ASME standard.

The low temperature and Cryogenic testing is carried out on site in our new state-of-the-art testing facility.

The test enclosure is able to test valves up to 72" and to pressures of 22,500 PSI, ensuring extensive coverage of the Crane Engineered Check product range.

TESTING – Our testing facility is capable of testing multiple specifications for HPGT and Cryogenics due to its intelligent programming system. The programming software is run using a barcode system, removing all manual inputs and, therefore, the potential for human error. Multiple procedures are stored on the control system. These comply with industry standards, ensuring a lean and efficient testing process. The system also has the flexibility to be customized to specific customer needs. For example, specific temperature or pressure requirements. On completion of testing, a certificate of conformance is generated by the system detailing leak rates, pressures and temperatures, as well as a graphical representation of the testing cycle.

Independent certification of BS 6364 capability (by Lloyds) on CRANE® DUO-CHEK® (add in the registered symbol) Cryogenic valves.

SAFETY is paramount. The test enclosure has been designed and implemented around this philosophy for all who interact with the facility. Key safety features include:

- Automatic interlock and lock-out personnel access door.
- Enclosure designed and tested to UL752 level 1 impact.
- 4 HD dome cameras with 10x optical zoom and 360° horizontal and 90° vertical rotation, coupled with remote monitoring via Internet access.
- Oxygen deficiency sensing connected directly to a high speed exhaust system for air quality.

Thermal Shocking

Low temperature thermal shocking of valve components can be carried out at the customer's request in our in-house testing facility. Valve components are dipped into liquid nitrogen at -196°C / -321°F, allowing the cold to penetrate throughout the castings. The components are then raised and allowed to return to ambient temperature before repeating the chilling effect. Carrying out this process during manufacturing on valve components minimises material structure changes which may affect performance when exposed to cryogenic liquids in service.



High Pressure Gas and Cryogenic In-House Testing

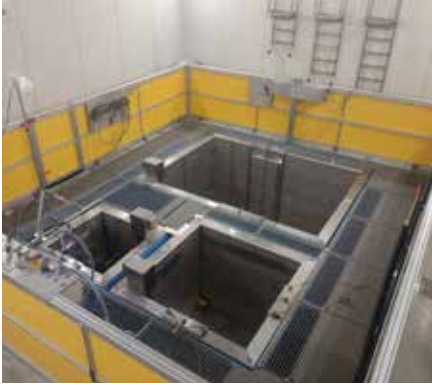

	Pressure	Test Temperature	End Connections	Typical Applications				
				LNG	Air Separation	Ethylene	Gas Compression	Gasoline
Cryogenic	Class 150 - 600	-196°C to Ambient -321°F to Ambient	Plain Face, Raised Face and RTJ	•	•	•		
High Pressure Gas	Class 150 - 600 API 6A 2000 - 10,000	Ambient	Plain Face, Raised Face and RTJ				•	•

Valve Configurations

Hub End Valves

Valves with Hub ends may be furnished for use with hub end, clamp-style connections. These end connections simplify installation procedures in systems that utilize them. Please contact our sales office for information regarding sizes and pressure ratings available, and other hub end connections such as Vector, etc.



Butt Weld Valves

Valves with butt weld ends may be furnished for piping systems designed for welded system components to eliminate potential joint leak paths. See Ordering Information for proper figure number designation, so that weld-end preparations match the mating pipe schedules.



Valve Configurations



STYLE G

Retainered Wafer

Sizes 2" – 88"

- ASME Classes 125 – 2500
- Retainered Wafer Design
- Dimensions pages 12–14



STYLE H

Retainerless Wafer

Sizes 2" – 88"

- ASME Classes 150 – 2500
- Dimensions pages 12–14

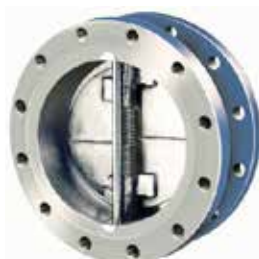

Retainerless Wafer Double Flange Valves

Sizes 2" – 88"

- ASME Classes 150 – 900
- Sizes & Dimensions page 12–14



Retainerless Wafer Lug Valves

Sizes 2" – 24"

- ASME Classes 150 – 2500
- Sizes & Dimensions page 12–14



STYLE X

Extended Body Wafer

Sizes 10" – 88"

- ASME Classes 150 – 2500
- Designed for extremely fast opening conditions
- Sizes & Dimensions page 12–14



STYLE P

Cryogenic Duo-Chek

Sizes 2"- 36"

- ASME Classes 150-600
- Designed for cryogenic applications to -196°C

Additional Engineered Check Products

Certificates

- ISO 9001
- ISO 14000
- ISO 45000
- API 6D
- PED
- FPAL
- ASME 6FD/6FA
- ABS
- CRN
- TR032



NOZ-CHEK® Full Body Nozzle Check Valves

- Sizes 1" – 84"
- ASME Classes 150 – 4500
- Flanged, Hub-End, Weld-End
- Iron, Steel, and Stainless Steel
- High Grade Alloys
- ASME, DIN, JIS Standards



COMPAC-NOZ® Compact Body Nozzle Check Valves

- Sizes 12" - 48"
- ASME Classes 150 - 2500
- Flanged
- Iron, Steel, and Stainless Steel
- High Grade Alloys
- ASME, DIN, JIS Standards



UNI-CHEK® Single-Disc Check Valves

- Sizes 2" – 36"
- ASME Classes 125 – 300
- Flanged, Plain, or Serrated Ends
- Cast Iron, Carbon Steel, and Stainless Steel
- High Grade Alloys
- Variety of external shaft options available

Additional Engineered Check Products



NOZ-CHEK®
Internally CRA Clad Flanged / Hubbed / Weld end

- Sizes: 2" – 84"
- ASME Classes 150 - 2500
- API 6A Pressure Rating up to 15000
- Non-Intergrated Diffuser
- ASME B16.34 & API 6D



NOZ-CHEK®
NOZ-CHEK Cryogenic

- Sizes: 1" – 48"
- ASME B16.34 & API 6D
- ASME Classes 150-4500



NOZ-CHEK®
Forged Flanged / Hubbed / Weld end

- Sizes: 0.75" – 24"
- ASME Classes 150 - 2500
- API 6A Pressure Rating up to 15000
- Non-intergrated Diffuser

Applications



Oil and Gas Production

- Centrifugal Compressor Discharge
- Fire Water Lines
- Oil/Steam Separation
- Steam and CO2 Injection
- Gas/Oil Gathering Systems
- Flowlines
- Wellheads
- Storage
- Tank Farms

Power Generation

- Steam
- Condensate
- Boiler Feed Pumps
- Cooling Towers
- Service Water Recirculators
- River Water Intake

Petroleum Refining

- Hydrogenation
- Cracking
- Steam
- Crude Oil
- Gasoline
- Visbreakers
- Naphtha
- Sulfur

Petrochemicals

- Ethylene

- Propylene
- Steam
- Reboilers
- Gases

Chemicals

- Chlorine
- Phosgene
- Aromatics
- Polymers
- Acids
- Air Separation
- Caustics

Water and Wastewater

- Distribution Lines
- Pumping Stations
- Sewage Plant Blower Discharge
- Chemical Treatment
- Fire Protection Systems
- HVAC Systems
- Desalination

Steel/Primary Metals

- Quench Lines
- De-Scaling

- Continuous Casters
- Steam
- Condensate
- Strippers
- Electro-Galvanizing

Pulp and Paper

- Bleaching Lines
- Black Liquor
- Green Liquor
- White Water
- Steam
- Chemical Recovery

Marine

- FPSO
- Oil Tankers
- Tanker Loading Terminals
- Offshore Platforms
- Sub-Sea Manifolds
- Terminal Transfer Lines
- Barge Unloading Lines
- Shipboard Services

Renewables

- Geothermal
- Solar
- Wave Power
- Hydro

- Carbon Capture
- Hydrogen

Typical Cryogenic Applications

- LNG (Regasification & Storage)
- Liquefaction Compression Train
- Mixed Refrigerant
- Ethylene Production
- Ethylene Refrigeration
- Air Separation Units





Ordering Information

Figure Number System

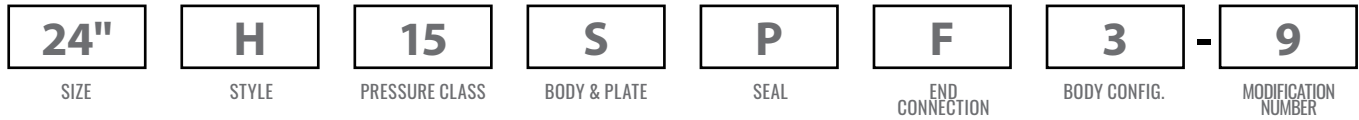

DESCRIPTION: 24" Style H, ASME Class 150, Carbon Steel Body, Metal Seal, raised face flanges, with double flange body, (modification number indicates Inconel® X spring)

Valve Size
Nominal valve sizes are expressed in inches or millimeters. In Inches: for use with ASME, API and B and A Flange Standards. In Millimeters: for use with DIN, or JIS rated valves (size preceded by "M" for DIN, or "J" for JIS).

Style		
Ordering Letter	Body Type	Size Range
H	Retainerless DUO-CHEK® Design Wafer, Lug, or Double Flange	2"-88" (50-2200mm)
G	Wafer, Retainered	2"-88" (50-2200mm)
X	Extended Body Design	10"-88" (150-2200mm)
P	Cryogenic	2 - 36" (50 - 900mm)

Pressure Classes	
ASME	
Class	Ordering No.
125	12
150	15
250	25
300	30
400	40
600	60
900	90
1500	150
2500	250
4500	450

Pressure Classes	
API ^Δ	
Class	Ordering No.
2000	21
3000	31
5000	51
10000	101
15000	151

Δ API Class is shown in psig, cold working pressure.

Example: **M 100 (4") G16 SPF -9**

Flange Standard
(M - DIN) (J - JIS)
100mm Size

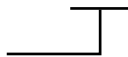

Pressure Rating,
PN for DIN or JIS
(in bars)

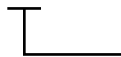

This specifies a metric valve, designed to fit between DIN flanges. Nominal size is 100 millimeters (corresponding to 4"), Style G DUO-CHEK® with a pressure rating of 16 bar, carbon steel body and plate, metal seat, raised face end connections and Inconel® X spring.

Ordering Information

Body					
Ordering Letter	Material	Specifications	Ordering Letter	Material	Specifications
BA	Ni-Aluminum Bronze	ASTM B148, C95800	T	317 S.S.	ASTM A351, Gr. CG-8M
C	316 Stainless Steel	ASTM A351, Gr. CF8M	U	WC6 Alloy Steel	ASTMA217, Gr. WC6 (11/4% Cr)
F	Alloy 20	ASTM A351, Gr. CN7M	V	347 S.S.	ASTM A351, Gr. CF-8C
H	Cast Iron with Al. Br. Plates	ASTM A126, class B	Y	C5 Alloy Steel	ASTM A217, Gr. C5 (5% Cr)
		ASTM B148, C95200	DZ	22% Duplex*	ASTM A995, Gr. 4A
K	Hastelloy® C	A494, Gr. CW12MW	EA	254 SMO Stainless	ASTM A351 CK3MCuN (UNS S31254)
L	C12 Alloy Steel	ASTM A217, Gr. C12 (9% Cr)	GC	LCC Low Temp. Steel	ASTM A352, Gr. LCC
M	Monel®	ASTM A494, Gr. M35-1	TT	Titanium*	ASTM B367, Gr. C2
S	Carbon Steel	ASTM A216, Gr. WCB	EB	25% Super Duplex*	ASTM A995, Gr 6A

* Not listed in B16.34

Hastelloy® C is a registered trademark of Haynes International, Inc.

Monel is a trademark of Special Metals Inc.

Seal ¹			
Ordering Letter	Material	Operating Temperature	
		°C	°F
A	EPDM	-18°C to 121°C	0°F to 250°F
M	Buna-N	-30°C to 121°C	-22°F to 250°F
N	Neoprene	-40°C to 121°C	-40°F to 250°F
P	As Body	-196°C to 538°C	-321°F to 1000°F
V	FKM-B	-20°C to 204°C	-4°F to 400°F
VM	Vermillion® 1	-43°C to 200°C	-45.4°F to 392°F
V2	Vermillion® 2	-28°C to 205°C	-18.4°F to 401°F
V3	Vermillion® 3	-32°C to 200°C	-25.6°F to 392°F
V4	Vermillion® 4	-19°C to 200°C	-2.2°F to 392°F
V5	Vermillion® 5	-38°C to 150°C	-36.4°F to 302°F
V6	Vermillion® 6	1°C to 205°C	33.8°F to 401°F

¹ This range of operating temperatures is for general guidance. The range varies with application, body and plate material.

End Connections	
Ordering Letter	Connections
F	Serrated face
G	Hub End
P	Plain Face (non serrated, Class 125)
R	Ring Joint
W	Weld-End*

*Weld-end valves also require the additional designation of the pipe schedule they are designed to fit.

Special Body Configurations	
Designation No.	Configuration
None (Blank)	Wafer Style, inserted between mating flanges with studs spanning entire length
1	Lug design w/threaded holes bolted from each end
2	Lug design with through-bolt holes to protect studs
3	Double flanged design with valve flanges bolted to individual line flanges

Ordering Information

Spring Selection Guide		
Spring Material	Operating Temperature	
	°C	°F
Type 316 S.S.	-200°C to 300°C	-328°F to 572°F
Inconel® X-750 (standard)	-200°C to 370°C	-328°F to 698°F
Inconel® X-750 (heat treated)*	-200 °C to 550°C	-328°F to 1022°F

* Available upon request

* For unique service conditions other spring materials are available. Please consult factory.

Common Modifications			
Mod No.	Material Description	API Trim No.*	Trim Description
-9	Inconel® X-750 Springs		
-14	316 S.S. Plate, Pins		
-39	410 S.S. Plate, Pins & Inconel® X-750 Springs		
-169	410 S.S. Plate, Pins, Inconel® X-750 Springs and 410 S.S. Overlay Seat	1	Type 410 S.S.
-201	316 S.S. Plate, Pins, Inconel® X-750 Springs		
-233	316 S.S. Plate, Pins, Inconel® X-750 Springs and 316 S.S. Overlay Seat	10	Type 316 S.S.
-491	Hard Face Plate, 316 SS, Pins, Inconel® X-750 Springs and Hard Face Seat	5	Hard Faced Seats
-559	Inconel® X-750 Spring and conformance to NACE MR0103		
-772	Monel® Plate, Pins, Springs, Bearings and Monel® Overlay Seat	9	Monel®
131E	410 S. S. Plate, pins, Inconel X-750 Springs and Hard Face Seat	8	F6 and Hard Faced
385E	316 S.S. Plate, Pins, Inconel X-750 Springs and Hard Face Seat	12	316 and Hard Faced

* Steel and steel alloy based metals.

* NACE MR0103 compliance offered on metal seated valves only.

CRANE®

CRANE CHEMPHARMA & ENERGY

4526 Research Forest Drive,
Suite 400
The Woodlands
Texas 77381, U.S.A.
Tel: +1 936 271 6500

Sydney, Australia Operations
146-154 Dunheved Circuit
St. Marys, NSW 2760 Australia
Tel: +61 2 9623 0234

Crane Process Flow Technologies
(Belfast)
Urban HQ, Eagle Star House,
5 – 7 Upper Queen Street,
Belfast, BT1 6FB
Tel: +44 (0) 28 9070 6322

Crane Process Flow Technologies (India) Pvt.
Ltd
E7 / E8 -2 Old MIDC
Satara - 415 004 India
Tel: +91 2162 244417

Xomox Chihuahua, S.A.
Juan Ruiz de Alarcón 313,
Complejo Industrial Chihuahua,
31136 Chihuahua, Mexico
Tel: +52 614 442 9860

Crane Company, and its subsidiaries cannot accept responsibility for possible errors in catalogues, brochures, other printed materials, and website information. Crane Company reserves the right to alter its products without notice, including products already on order provided that such alteration can be made without changes being necessary in specifications already agreed. All trademarks in this material are the property of the Crane Company or its subsidiaries. The Crane and Crane brands logotype (ALOYCO®, BAUM®, CENTER LINE®, CRANE®, CRYOFLO®, DEPA® & ELRO®, DOPAK®, DUO-CHEK®, FLOWSEAL®, GYROLOK®, GO REGULATOR®, HOKE®, JENKINS®, KROMBACH®, NOZ-CHEK®, PACIFIC VALVES®, RESISTOFLEX®, REVO®, SAUNDERS®, STOCKHAM®, TEXAS SAMPLING®, WESTLOCK CONTROLS®, WTA®, and XOMOX®) are registered trademarks of Crane Co. All rights reserved.