



技术数据表

ASME 设计

CRANE® FK-TrieX™ 适用于严苛工况的全通路三 偏置隔离阀

高 Cv 阀可减少管路尺寸

CRANE®

 www.cranecpe.com

特点和优势

适用于严苛工况的 CRANE® FK-TRIEX™ 全通径三偏置隔离阀

CRANE® FK-TrieX™ 是一种创新的直角回转技术,也是唯一具有行业领先 Cv 的隔离阀,可以提供双向无气泡关断,具有无与伦比的可靠性和低总体成本。

标准设计

- 符合 API 6D 规范
 - 双向零泄漏
 - 可按 6.2.1 节规定进行排泄
- 符合 ISO 15848-1 AH CO3 和 API 641 的散逸性排放控制标准
- 符合 API 607 的防火设计
- ASME B16.10 双法兰长球阀
- 无空腔自清洁设计
- 真空等级
- ISO 5211 整体式安装法兰

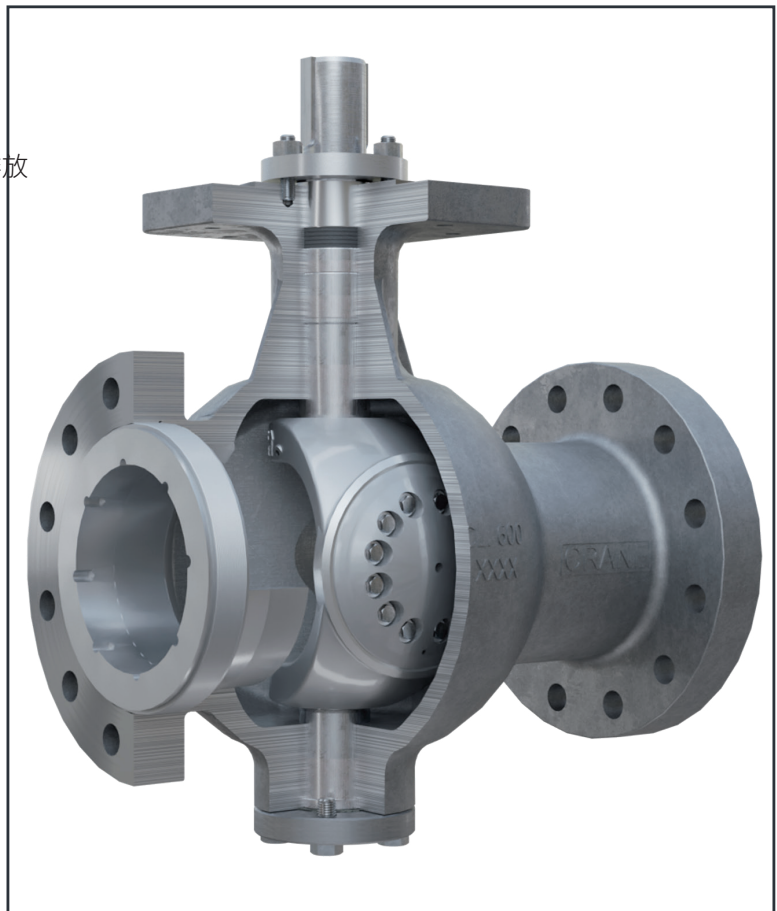

可选设计

- 压紧式轴承设计
- 加热套
- 设计符合 NACE MR0175 / MRO103 标准
- CE/PED 双重认证

产品范围

尺寸	磅级	阀体设计	法兰距尺寸	主体材质
6"-36" DN 150-900	150-600 磅级	单件式阀体设计 长型双法兰盘	ASME B16.10 长型 (球阀)	WCB / 1.0619 CF8M / 1.4408



剖析图

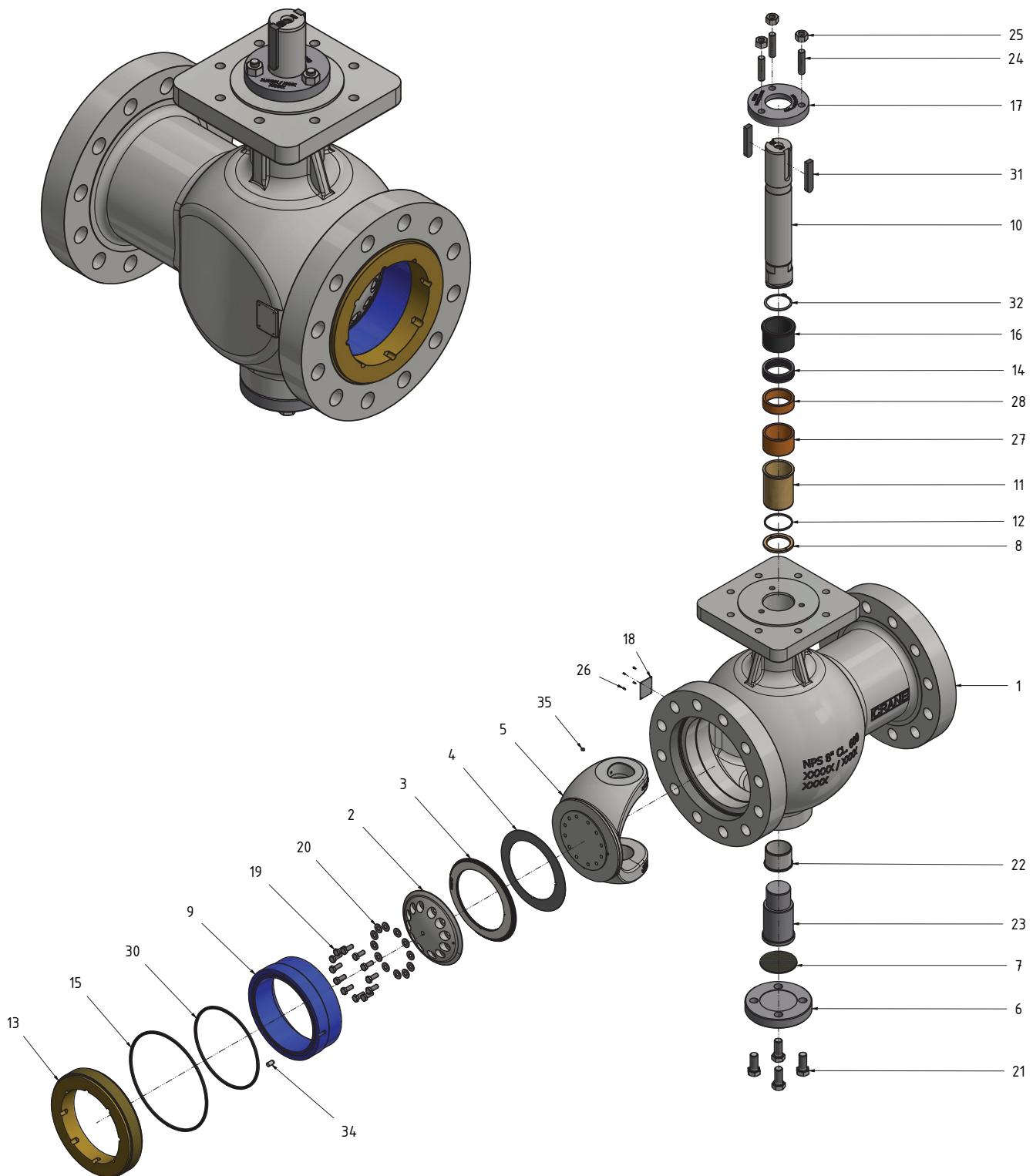

项目	说明	碳钢 最高温度 700°F / 371°C*		不锈钢 最高温度 700°F / 371°C*	
		ASTM	DIN	ASTM	DIN
1	阀体	A216 Gr.WCB	1.0619	A351 Gr CF8M	1.4408
2	密封挡圈环	A515 Gr.60	1.0425	A240 Gr.321	1.4541
3	层压密封件	S31803/石墨	1.4462/石墨	S31803/石墨	1.4462/石墨
4	密封垫圈	石墨			
5	阀瓣	A216 Gr.WCB	1.0619	A351 Gr CF8M	1.4408
6	盖板	A516 Gr.60/A105	1.0425	A240 Gr.321	1.4541
7	盖板垫圈	石墨			
8	分体环	A182 Gr.F51	1.4462	A182 Gr.F51	1.4462
9	Triex 环	A105 / A216 Gr.WCB	1.0482 / 1.0619	A182-F316/ A351 Gr CF8M	1.4408
10	阀轴	A564 Gr.630 (17-4 PH)	1.4542	A564 Gr.630 (17-4 PH)	1.4542
11	轴承	A582 Gr.303 涂层	1.4305 涂层	A582 Gr.303 涂层	1.4305 涂层
12	轴承保护器	石墨			
13	插件	A105 / A216 Gr.WCB	1.0482 / 1.0619	A182-F316/ A351 Gr CF8M	1.4408
14	填料	石墨			
15	C 型密封件	Inconel 718	Inconel 718	Inconel 718	Inconel 718
16	压盖	A582 Gr.303	1.4305	A582 Gr.303	1.4305
17	压盖法兰	A516 Gr.60	1.0425	A240 Gr.321	1.4541
18	铭牌	A240 Gr.304	1.4301	A240 Gr.304	1.4301
19	挡圈螺钉	A193 Gr.B8	A4-70	A193 Gr.B8	A4-70
20	弹簧垫片	A4/ASTM 316			
21	盖板螺钉	A193 Gr.B8	A4-70	A193 Gr.B8	A4-70
22	阀瓣轴承	A582 Gr.303 涂层	1.4305 涂层	A582 Gr.303 涂层	1.4305 涂层
23	底轴	A564 Gr.630 (17-4 PH)	1.4542	A564 Gr.630 (17-4 PH)	1.4542
24	压盖螺柱	A193 Gr.B8	A4-70	A193 Gr.B8	A4-70
25	压盖螺母	A194 Gr.8	A4-70	A194 Gr.8	A4-70
26	缺口钉	A29,Gr1012 镀锌	A4-70	A29,Gr1012 镀锌	A4-70
27	上垫圈	A582 Gr.304	1.4305	A582 Gr.304	1.4305
28	下垫圈	A582 Gr.304	1.4305	A582 Gr.304	1.4305
30	C 型密封件	Inconel 718	Inconel 718	Inconel 718	Inconel 718
31	横楔	A194 Gr.2	1.1191	A194 Gr.2	1.1191
32	圈套	1.4310/1.4122/ ASTM 301			
34	销钉	SS316	1.4401	SS316	1.4401
35	螺纹钉	A193 Gr.B8	A4-70	A193 Gr.B8	A4-70

* 如需适于更高温度的产品, 请咨询工厂

尺寸和重量 (150 磅级)

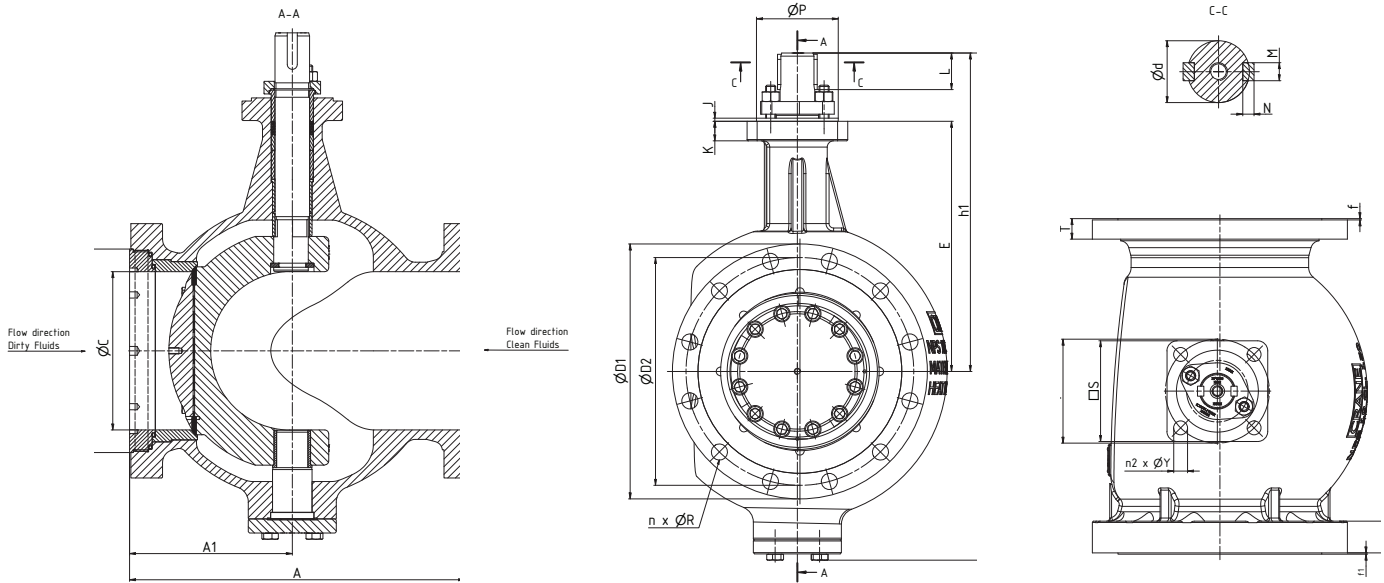

DN	NPS	尺寸 (英寸)														
		A	$\varnothing C$	H	h1	E	$\varnothing D1$	$\varnothing D2$	n	$\varnothing R$	$\varnothing B$	T	f	T1	f1	A1
150	6"	16	5.9	24	16	12	11	10	8	0.87	8	1.0	0.08	1.5	0.08	6.4
200	8"	18	7.9	26	17	13	14	12	8	0.88	11	1.1	0.08	1.7	0.08	8.4
250	10"	21	9.9	32	20	16	16	14	12	1.00	13	1.2	0.08	2.0	0.08	10.2
300	12"	24	12	37	23	17	19	17	12	1.00	15	1.3	0.08	2.1	0.08	12.0
350	14"	27	13	42	26	20	21	19	12	1.12	16	1.4	0.08	2.3	0.08	13.1
400	16"	30	15	44	27	21	23	21	16	1.13	19	1.5	0.08	2.4	0.08	13.8
450	18"	34	17	48	29	22	25	23	16	1.26	21	1.6	0.08	2.4	0.08	15.7
500	20"	36	19	52	31	24	28	25	20	1.26	23	1.7	0.08	2.5	0.08	18.4
600	24"	42	23	64	39	30	32	30	20	1.38	27	1.9	0.08	2.9	0.08	20.7
700	28"	如需尺寸 28"-36" / DN700-900, 请咨询工厂														
750	30"															
800	32"															
900	36"															

DN	NPS	尺寸 (英寸)											
		ISO 5211	S (平方)	$\varnothing P$	$\varnothing F$	n2	$\varnothing Y$	K	J	$\varnothing d$	L	M	N
150	6"	F16	6.7	5.1	6.5	4	0.9	1.4	0.2	1.8	2.0	0.6	0.4
200	8"	F16	6.7	5.1	6.5	4	0.9	1.4	0.2	1.8	2.0	0.6	0.4
250	10"	F16	6.3	5.1	6.5	4	0.9	1.2	0.2	2.2	2.3	0.6	0.4
300	12"	F25	11	8	10	8	0.7	1.3	0.2	2.6	2.8	0.7	0.4
350	14"	F25	11	8	10	8	0.7	1.3	0.2	3.0	2.8	0.8	0.5
400	16"	F25	11	8	10	8	0.7	1.3	0.2	3.0	3.1	0.8	0.5
450	18"	F30	13	9	12	8	0.8	1.5	0.2	3.5	4.1	1.0	0.5
500	20"	F30	13	9	12	8	0.8	1.5	0.2	3.5	4.1	1.0	0.5
600	24"	F35	16	10	14	8	1.3	1.9	0.2	4.3	6.3	1.1	0.6
700	28"	如需尺寸 28"-36" / DN700-900, 请咨询工厂											
750	30"												
800	32"												
900	36"												

尺寸和重量 (150 磅级)

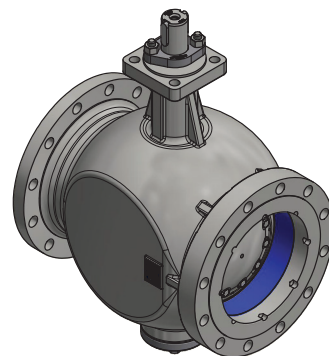
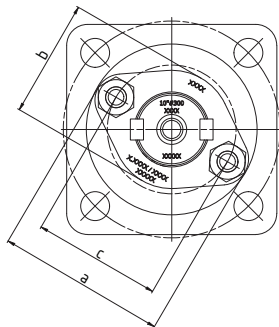
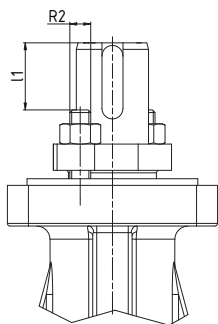

DN	NPS	尺寸 (英寸)					重量 (磅)
		a	b	c	l1	R2	
150	6"	5.1	3.5	4.0	1.7	5/8-11 UNC	191
200	8"	5.1	3.5	4.0	1.8	5/8-11 UNC	330
250	10"	5.1	3.5	3.9	2.0	5/8-11 UNC	506
300	12"	6.7	4.7	5.1	2.2	3/4-10 UNC	847
350	14"	7.8	5.5	5.9	2.2	1-8 UNC	1136
400	16"	7.8	5.5	5.9	2.2	1-8 UNC	1401
450	18"	8.9	6.7	6.9	3.7	1-8 UNC	1857
500	20"	8.9	6.7	6.9	3.7	1-8 UNC	2309
600	24"	10.2	-	8.0	5.3	1-8 UNC	3931
700	28"	如需尺寸 28"-36"/ DN700-900, 请咨询工厂					
750	30"						
800	32"						
900	36"						

尺寸和重量 (150 磅级)

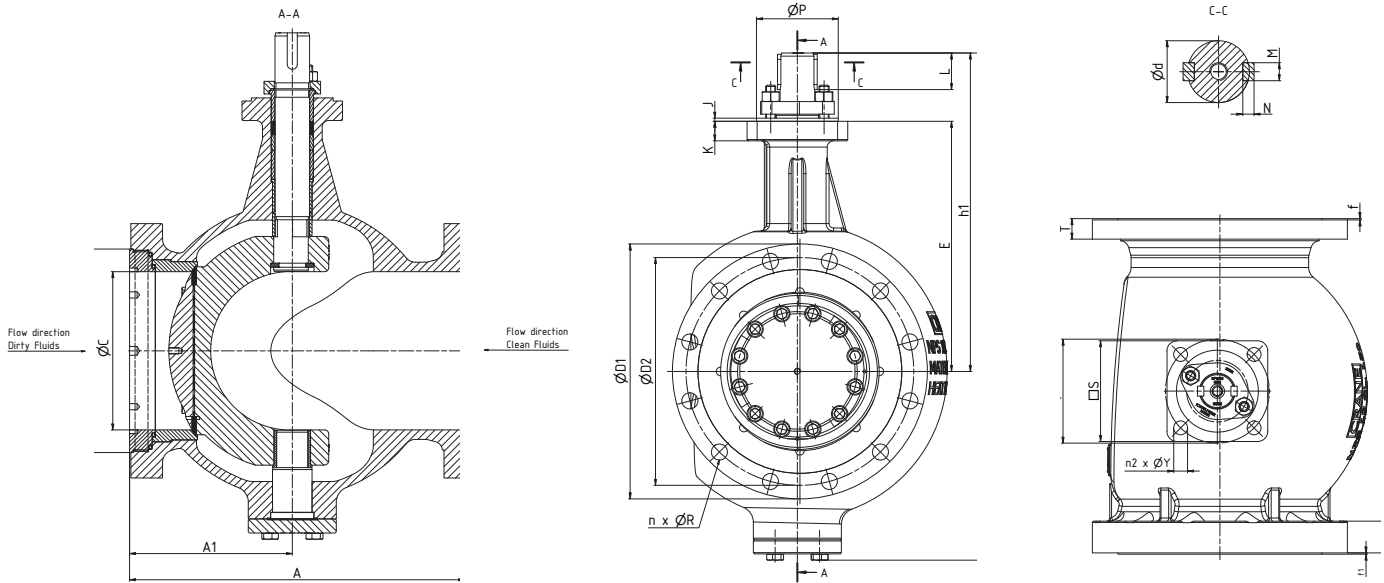

DN	NPS	尺寸(毫米)														
		A	Ø C	H	h1	E	Ø D1	Ø D2	n	Ø R	Ø B	T	f	T1	f1	A1
150	6"	394	150	597	395	299	280	241	8	22	216	26	2	39	2	163
200	8"	457	201	663	424	327	345	299	8	22	270	29	2	44	2	213
250	10"	533	252	806	506	398	405	362	12	25	324	31	2	51	2	259
300	12"	610	305	931	572	435	485	432	12	25	381	32	2	52	2	306
350	14"	686	334	1059	659	506	535	476	12	29	413	35	2	58	2	333
400	16"	762	373	1113	680	527	595	540	16	29	470	37	2	61	2	352
450	18"	864	436	1223	740	567	635	578	16	32	533	40	2	61	2	400
500	20"	914	487	1333	800	607	700	635	20	32	584	43	2	63	2	468
600	24"	1067	589	1621	995	774	815	749	20	35	692	48	2	74	2	527
700	28"	如需尺寸 28"-36" / DN700-900, 请咨询工厂														
750	30"															
800	32"															
900	36"															

DN	NPS	尺寸(毫米)											
		ISO 5211	S(平方)	Ø P	Ø F	n2	Ø Y	K	J	Ø d	L	M	N
150	6"	F16	170	130	165	4	22	35	5	45	52	14	9
200	8"	F16	170	130	165	4	22	35	5	45	52	14	9
250	10"	F16	160	130	165	4	22	31	5	55	58	16	10
300	12"	F25	270	200	254	8	17.5	34	5	65	72	18	11
350	14"	F25	280	200	254	8	17.5	33	5	75	72	20	12
400	16"	F25	280	200	254	8	17	33	5	75	80	20	12
450	18"	F30	330	230	298	8	21	38	5	90	103	25	12
500	20"	F30	330	230	298	8	21	38	5	90	103	25	12
600	24"	F35	410	260	356	8	33	49	5	110	160	28	16
700	28"	如需尺寸 28"-36" / DN700-900, 请咨询工厂											
750	30"												
800	32"												
900	36"												

尺寸和重量 (150 磅级)

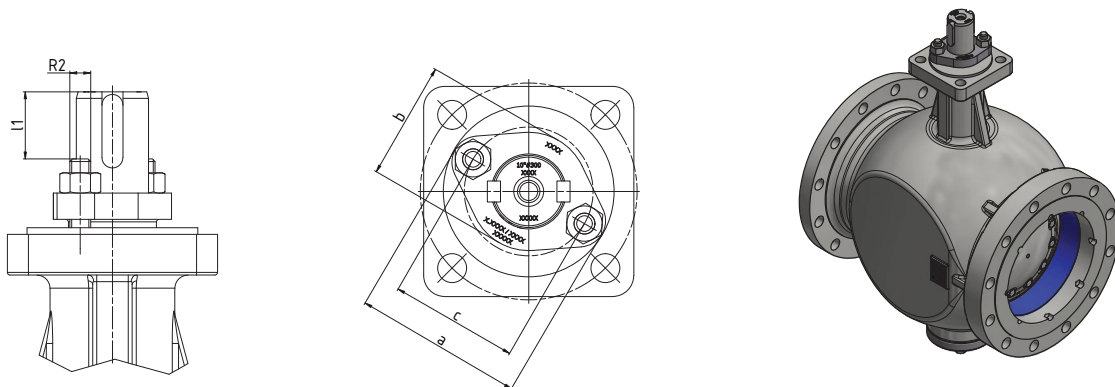

DN	NPS	尺寸 (毫米)					重量 (千克)	
		a	b	c	l1	R2		
150	6"	129	90	102	44	5/8-11 UNC	87	
200	8"	129	90	102	45	5/8-11 UNC	150	
250	10"	129	90	98	51	5/8-11 UNC	230	
300	12"	170	120	130	56	3/4-10 UNC	384	
350	14"	198	140	150	49	1-8 UNC	515	
400	16"	198	140	150	54	1-8 UNC	636	
450	18"	225	170	175	95	1-8 UNC	843	
500	20"	225	170	175	95	1-8 UNC	1048	
600	24"	258	-	204	136	1-1-8 UNC	1783	
700	28"	如需尺寸 28"-36" / DN700-900, 请咨询工厂						
750	30"							
800	32"							
900	36"							

尺寸和重量 (300 磅级)

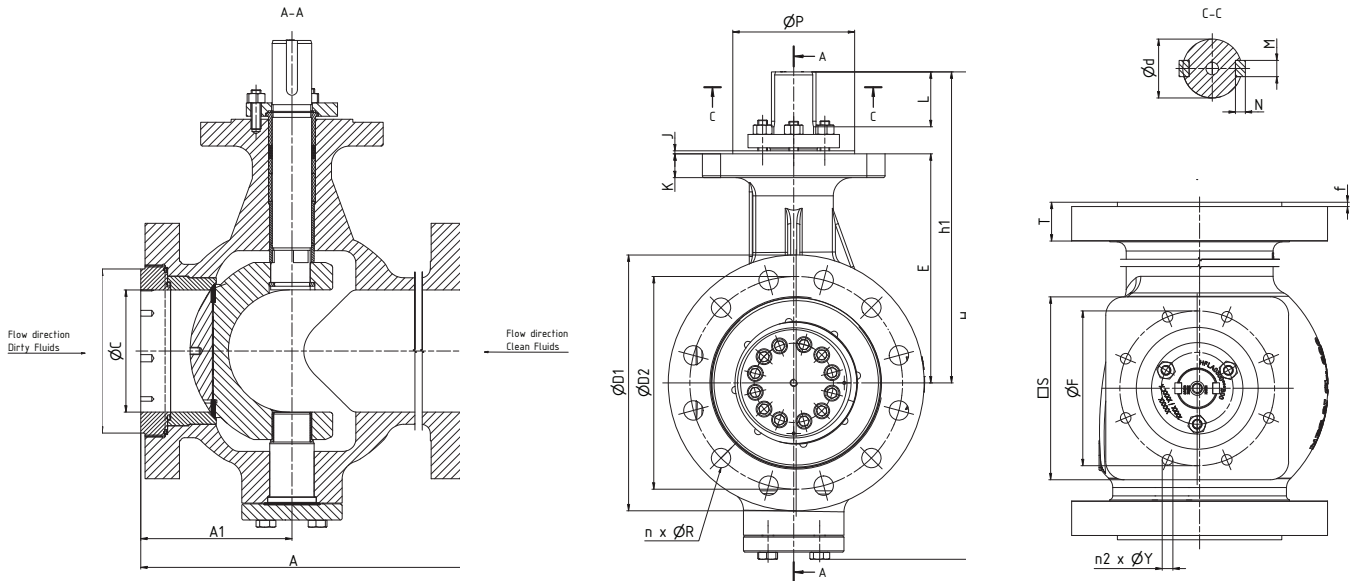

DN	NPS	尺寸 (英寸)												
		A	Ø C	H	h1	E	Ø D1	Ø D2	n	Ø R	Ø B	T	f	A1
150	6"	16	6	23	15	12	13	11	12	0.9	9	1.5	0.08	6
200	8"	20	8	26	17	13	15	13	12	1.0	11	1.7	0.08	8
250	10"	22	10	32	20	16	18	15	16	1.1	13	1.9	0.08	10
300	12"	26	12	37	23	17	20	18	16	1.3	15	2.0	0.08	12
350	14"	30	13	42	26	20	23	20	20	1.3	16	2.1	0.08	13
400	16"	33	15	44	27	21	26	23	20	1.4	18	2.3	0.08	14
450	18"	36	17	51	31	25	28	25	24	1.4	21	2.4	0.08	16
500	20"	39	19	53	32	26	31	27	24	1.4	23	2.5	0.08	18
600	24"	45	23	57	34	25	36	32	24	1.7	27	2.8	0.08	21
700	28"	如需尺寸 28"-36"/ DN700-900, 请咨询工厂												
750	30"													
800	32"													
900	36"													

DN	NPS	尺寸 (英寸)											
		ISO 5211	S (平方)	Ø P	Ø F	n2	Ø Y	K	J	Ø d	L	M	N
150	6"	F16	6.7	5.1	6.5	4	0.9	1.4	0.2	1.8	2.0	0.6	0.4
200	8"	F16	6.3	5.1	6.5	4	0.9	1.4	0.2	1.8	2.0	0.6	0.4
250	10"	F16	6.3	5.1	6.5	4	0.9	1.2	0.2	2.2	2.3	0.6	0.4
300	12"	F25	10.6	7.9	10.0	8	0.7	1.3	0.2	2.6	2.8	0.7	0.4
350	14"	F25	11.0	7.9	10.0	8	0.7	1.3	0.2	2.95	2.8	0.8	0.5
400	16"	F25	11.0	7.9	10.0	8	0.7	1.3	0.2	3.0	3.1	0.8	0.5
450	18"	F30	12.6	9.1	11.7	8	0.8	1.5	0.2	3.5	3.7	1.0	0.5
500	20"	F30	13.0	10.2	11.7	8	0.9	1.5	0.2	3.5	3.7	1.0	0.5
600	24"	F35	16.3	10.2	14.0	8	1.2	1.7	0.2	4.3	6.3	1.1	0.6
700	28"	如需尺寸 28"-36"/ DN700-900, 请咨询工厂											
750	30"												
800	32"												
900	36"												

尺寸和重量 (300 磅级)

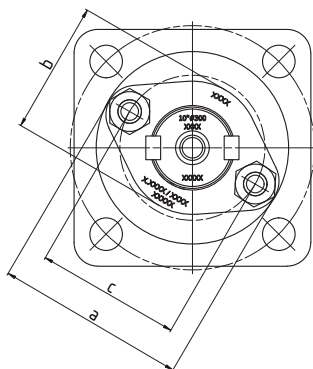
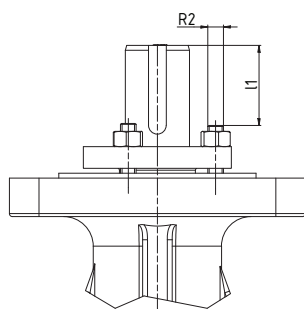

尺寸 6"-20"

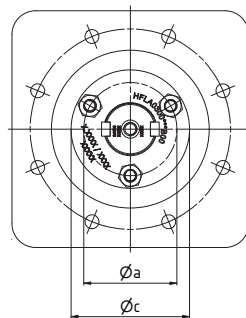

尺寸 24"-36"

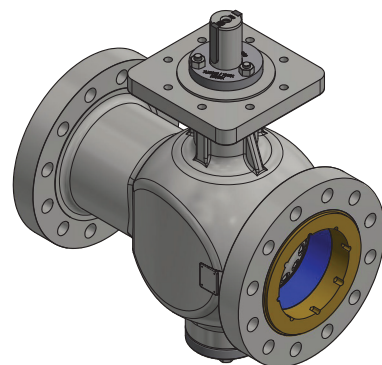

DN	NPS	尺寸 (英寸)					重量 (磅)	
		a / Ø a	b	c / Ø c	l1	R2		
150	6"	5.1	3.5	4.0	1.7	5/8-11 UNC	230	
200	8"	5.1	3.5	4.0	1.7	5/8-11 UNC	398	
250	10"	5.1	3.5	3.9	2.0	5/8-11 UNC	615	
300	12"	6.7	4.7	5.1	2.2	3/4-10 UNC	986	
350	14"	7.8	5.5	5.9	1.9	1-8 UNC	1368	
400	16"	7.8	5.5	5.9	2.1	1-8 UNC	1770	
450	18"	8.9	6.7	6.9	2.0	1-8 UNC	2484	
500	20"	8.9	6.7	6.9	2.0	1-8 UNC	3142	
600	24"	8.3	-	6.4	6.0	1-8 UNC	6226	
700	28"	如需尺寸 28"-36" / DN700-900, 请咨询工厂						
750	30"							
800	32"							
900	36"							

尺寸和重量 (300 磅级)

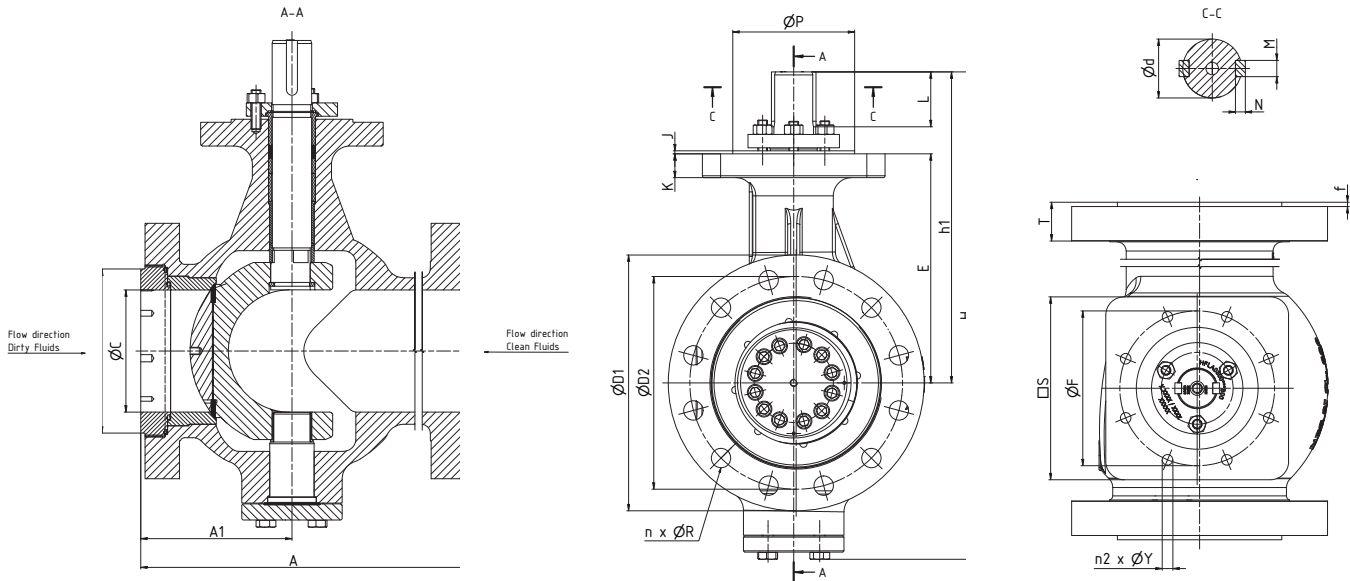

DN	NPS	尺寸(毫米)												
		A	ØC	H	h1	E	ØD1	ØD2	n	ØR	ØB	T	f	A1
150	6"	403	152	596	393	299	320	270	12	22	216	37	2	163
200	8"	502	203	662	423	329	380	330	12	25	270	43	2	203
250	10"	568	254	807	507	399	445	387	16	29	324	48	2	259
300	12"	648	305	931	572	435	520	451	16	32	381	51	2	316
350	14"	762	336	1059	659	506	585	514	20	32	413	54	2	323
400	16"	838	387	1127	687	534	650	572	20	35	470	58	2	364
450	18"	914	432	1290	777	625	710	629	24	35	533	61	2	414
500	20"	991	487	1356	814	662	775	686	24	35	584	64	2	451
600	24"	1143	589	1443	860	647	915	813	24	42	692	72	2	526
700	28"	如需尺寸 28"-36"/ DN700-900, 请咨询工厂												
750	30"													
800	32"													
900	36"													

DN	NPS	尺寸(毫米)											
		ISO 5211	S(平方)	ØP	ØF	n2	ØY	K	J	Ød	L	M	N
150	6"	F16	170	130	165	4	22	35	5	45	52	14	9
200	8"	F16	160	130	165	4	22	35	5	45	52	14	9
250	10"	F16	160	130	165	4	22	31	5	55	58	16	10
300	12"	F25	270	200	254	8	17.5	34	5	65	72	18	11
350	14"	F25	280	200	254	8	17.5	33	5	75	72	20	12
400	16"	F25	280	200	254	8	17	33	5	75	80	20	12
450	18"	F30	320	230	298	8	21	38	5	90	94	25	12
500	20"	F30	330	260	298	8	22	38	5	90	94	25	12
600	24"	F35	415	260	356	8	31	44	5	110	160	28	16
700	28"	如需尺寸 28"-36"/ DN700-900, 请咨询工厂											
750	30"												
800	32"												
900	36"												

尺寸和重量 (300 磅级)

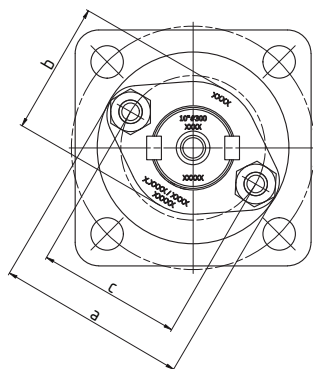
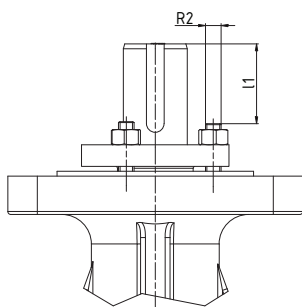

尺寸 6"-20"

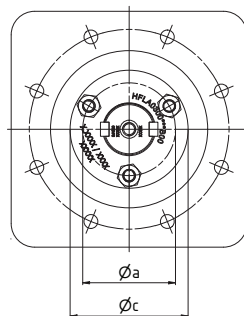

尺寸 24"-36"

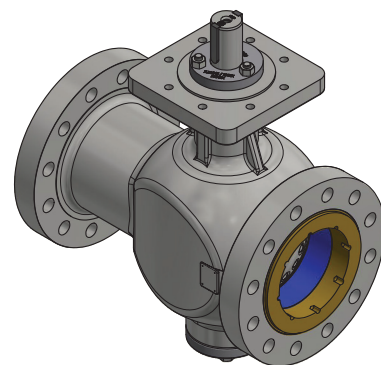

DN	NPS	尺寸 (毫米)					重量 (千克)	
		a / $\varnothing a$	b	c / $\varnothing c$	l1	R2		
150	6"	129	90	102	42	5/8-11 UNC	105	
200	8"	129	90	102	44	5/8-11 UNC	181	
250	10"	129	90	98	52	5/8-11 UNC	279	
300	12"	170	120	130	56	3/4-10 UNC	447	
350	14"	198	140	150	49	1-8 UNC	621	
400	16"	198	140	150	52	1-8 UNC	803	
450	18"	225	170	175	52	1-8 UNC	1127	
500	20"	225	170	175	52	1-8 UNC	1426	
600	24"	210	-	162	152	1-8 UNC	2825	
700	28"	如需尺寸 28"-36"/DN700-900, 请咨询工厂						
750	30"							
800	32"							
900	36"							

尺寸和重量 (600 磅级)

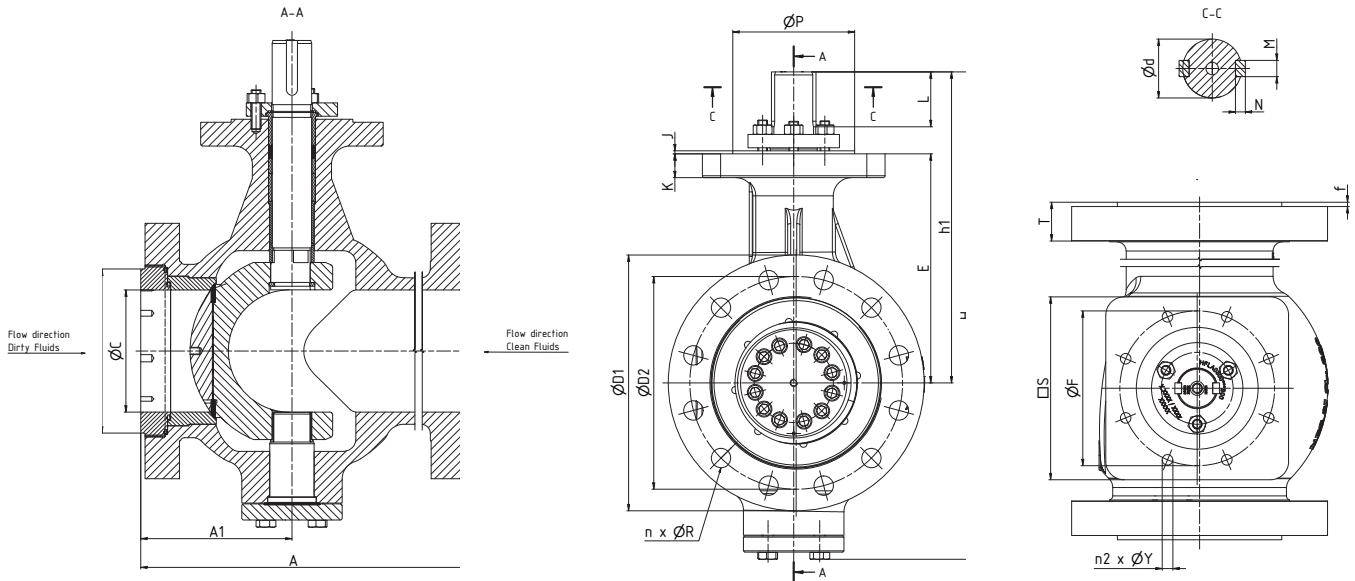

DN	NPS	尺寸 (英寸)												
		A	ØC	H	h1	E	ØD1	ØD2	n	ØR	ØB	T	f	A1
150	6"	22	6	25	16	12	14	11	12	1.1	8.5	2.0	0.28	8
200	8"	26	8	31	20	15	17	14	12	1.3	10.6	2.2	0.28	10
250	10"	31	10	37	24	18	20	17	16	1.4	13	2.6	0.28	12
300	12"	33	12	41	26	20	22	19	20	1.4	15	2.7	0.28	13
350	14"	35	13	45	27	20	24	21	20	1.5	16	2.8	0.28	13
400	16"	39	15	49	31	23	27	24	20	1.6	19	3.1	0.28	15
450	18"	43	17	55	35	26	29	26	20	1.8	21	3.3	0.28	18
500	20"	47	19	60	37	28	32	29	24	1.7	23	3.5	0.28	19
600	24"	55	22	69	42	30	37	33	24	2.0	27	4.1	0.28	21
700	28"	如需尺寸 28"-36"/ DN700-900, 请咨询工厂												
750	30"													
800	32"													
900	36"													

DN	NPS	尺寸 (英寸)											
		ISO 5211	S (平方)	ØP	ØF	n2	ØY	K	J	Ød	L	M	N
150	6"	F16	6	5	6	4	0.9	0.8	0.20	1.8	2.5	0.6	0.4
200	8"	F25	12	8	10	8	0.7	1.5	0.20	2.6	3.5	0.7	0.4
250	10"	F30	14	9	12	8	0.9	1.6	0.20	2.8	3.9	0.8	0.5
300	12"	F30	14	9	12	8	0.9	1.6	0.20	3.1	3.9	0.9	0.6
350	14"	F30	14	9	12	8	0.9	1.6	0.20	3.5	4.9	1.0	0.6
400	16"	F35	16	10	14	8	1.3	2.1	0.20	3.9	5.5	1.1	0.6
450	18"	F40	16	10	14	8	1.3	2.1	0.20	4.3	6.3	1.1	0.6
500	20"	F48	19	12	16	8	1.5	2.4	0.39	4.7	7.1	1.3	0.7
600	24"	F48	22	15	19	12	1.5	2.8	0.39	5.5	8.7	1.4	0.8
700	28"	如需尺寸 28"-36"/ DN700-900, 请咨询工厂											
750	30"												
800	32"												
900	36"												

尺寸和重量 (600 磅级)

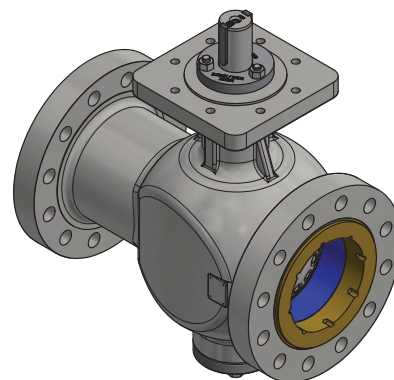
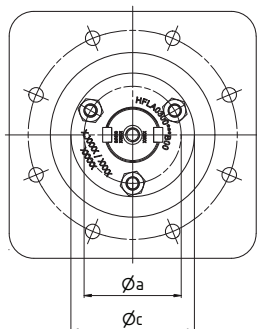
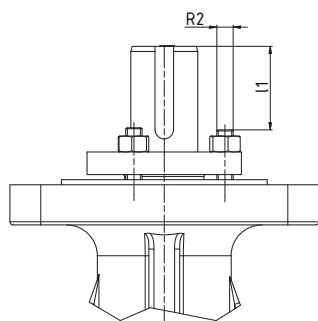

DN	NPS	尺寸 (英寸)				重量 (磅)
		Ø a	Ø c	l1	R2	
150	6"	4.8	3.7	2.6	9/16-12 UNC	366
200	8"	5.9	4.6	3.2	5/8-11 UNC	674
250	10"	6.8	5.3	3.7	3/4-10 UNC	1106
300	12"	8.3	6.4	3.5	1-8 UNC	1496
350	14"	8.7	6.8	4.2	1-8 UNC	1720
400	16"	9.1	7.2	4.6	1-8 UNC	2617
450	18"	10	8.0	5.3	1-8 UNC	3640
500	20"	11	8.7	7.0	1 1/2-8 UNC	4788
600	24"	13	10.4	9.0	1 1/2-8 UNC	7022
700	28"	如需尺寸 28"-36" / DN700-900, 请咨询工厂				
750	30"					
800	32"					
900	36"					

尺寸和重量 (600 磅级)

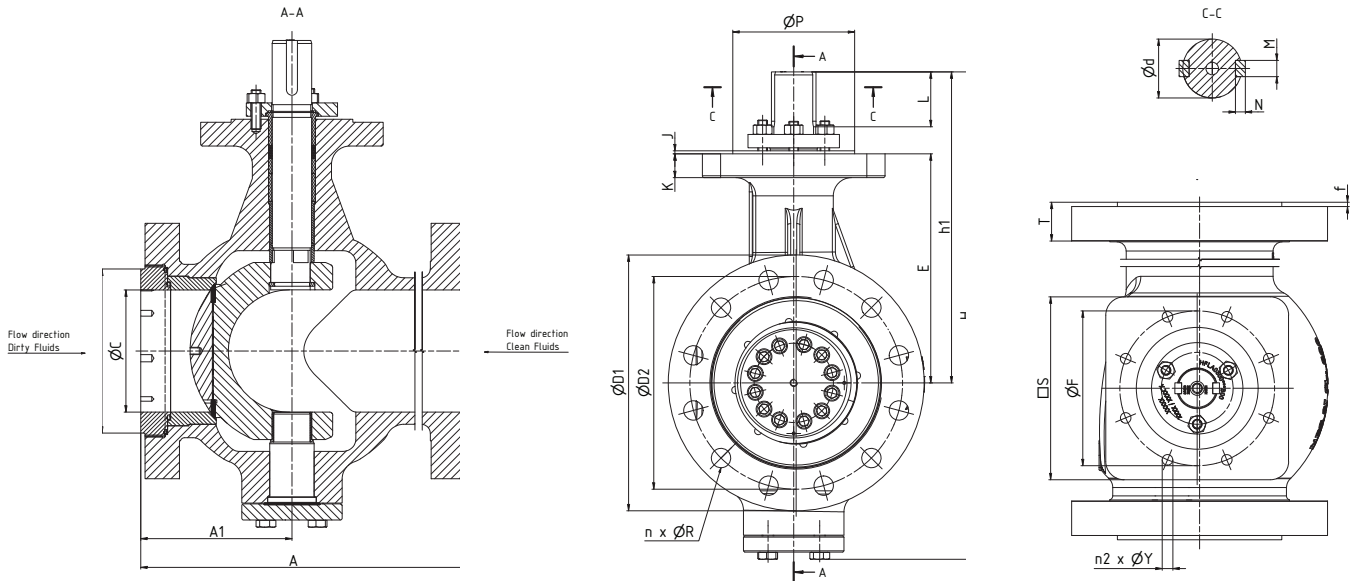

DN	NPS	尺寸(毫米)												
		A	ØC	H	h1	E	ØD1	ØD2	n	ØR	ØB	T	f	A1
150	6"	559	152	634	416	308	355	292	12	28	216	50	7	211
200	8"	660	201	800	511	376	420	349	12	32	270	56	7	249
250	10"	787	252	949	608	450	510	432	16	35	324	66	7	293
300	12"	838	303	1051	671	506	560	489	20	35	381	69	7	328
350	14"	889	327	1136	698	510	605	527	20	38	413	71	7	327
400	16"	991	385	1249	775	578	685	603	20	41	470	78	7	387
450	18"	1092	436	1409	880	664	745	654	20	45	533	85	7	451
500	20"	1194	487	1519	940	704	815	724	24	44	584	89	7	490
600	24"	1397	561	1750	1076	755	940	838	24	51	692	105	7	526
700	28"	如需尺寸 28"-36"/ DN700-900, 请咨询工厂												
750	30"													
800	32"													
900	36"													

DN	NPS	尺寸(毫米)											
		ISO 5211	S(平方)	ØP	ØF	n2	ØY	K	J	Ød	L	M	N
150	6"	F16	160	130	165	4	22	20	5	45	63	14	9
200	8"	F25	300	200	254	8	17.5	39	5	65	90	18	11
250	10"	F30	350	230	298	8	22	40	5	70	100	20	12
300	12"	F30	350	230	298	8	22	40	5	80	100	22	14
350	14"	F30	350	230	298	8	22	40	5	90	125	25	14
400	16"	F35	410	260	356	8	33	53	5	100	140	28	16
450	18"	F40	415	260	356	8	33	53	5	110	160	28	16
500	20"	F40	475	300	406	8	39	60	10	120	180	32	18
600	24"	F48	560	370	483	12	39	72	10	140	220	36	20
700	28"	如需尺寸 28"-36"/ DN700-900, 请咨询工厂											
750	30"												
800	32"												
900	36"												

尺寸和重量 (600 磅级)

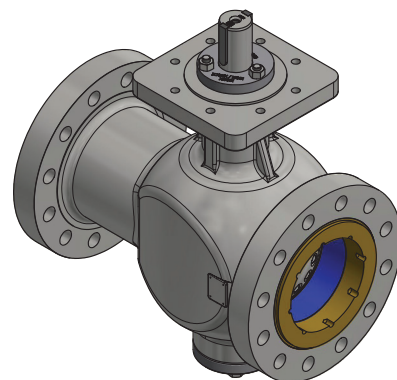
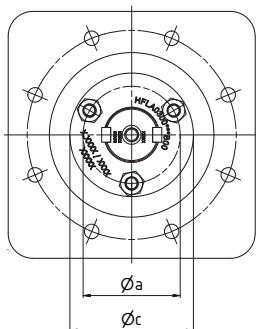
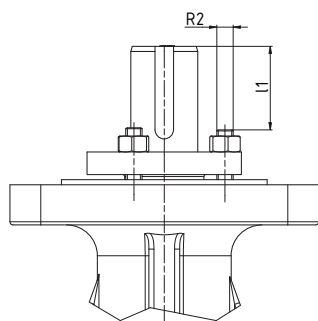

DN	NPS	尺寸(毫米)				重量(千克)
		Ø a	Ø c	l1	R2	
150	6"	122	94	63.4	9/16-12 UNC	166
200	8"	150	118	79	5/8-11 UNC	306
250	10"	172	134	91	3/4-10 UNC	502
300	12"	210	162	86	1-8 UNC	679
350	14"	220	172	102	1-8 UNC	781
400	16"	230	182	113	1-8 UNC	1187
450	18"	258	204	130	1-8 UNC	1652
500	20"	280	222	172	1 1/2-8 UNC	2173
600	24"	334	264	220	1 1/2-8 UNC	3186
700	28"	如需尺寸 28"-36" / DN700-900, 请咨询工厂				
750	30"					
800	32"					
900	36"					

压力/温度额定值

温度	最大工作压力	最大工作压力	最大工作压力
	ASME 150 磅级	ASME 300 磅级	ASME 600 磅级
	ASTM A216 Gr.WCB*		
°F	psi		
-20	285	740	1480
100	285	740	1480
200	260	680	1360
300	230	655	1310
400	200	635	1265
500	170	605	1205
600	140	570	1135
650	125	550	1100
700	110	530	1060
750**	95	505	1015
800**	80	410	825

*根据 ASME B16.34 - 材质组 1.1
**咨询工厂以选择适当的材质

温度	最大工作压力	最大工作压力	最大工作压力
	ASME 150 磅级	ASME 300 磅级	ASME 600 磅级
	ASTM A351 Gr.CF8M*		
°F	psi		
-76	275	720	1440
-20	275	720	1440
100	275	720	1440
200	235	620	1240
300	215	560	1120
400	195	515	1025
500	170	480	955
600	140	450	900
650	125	440	885
700**	110	435	870
750**	95	425	855
800**	80	420	845
850**	65	420	835
900**	50	415	830
950**	35	385	775
1000**	20	365	725

*根据 ASME B16.34 - 材质组 2.2
**咨询工厂以选择适当的材质

压力和温度
ASTM A216 Gr.WCB

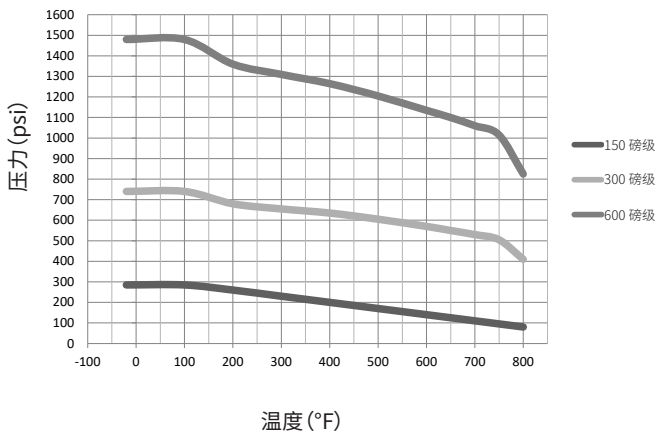

压力和温度
ASTM A351 Gr.CF8M

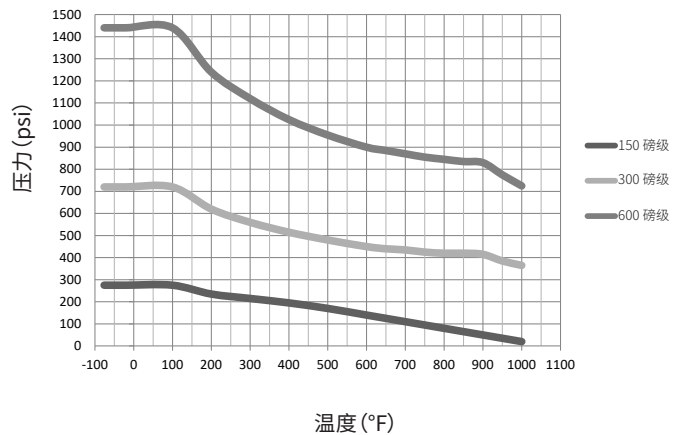

压力/温度额定值

温度	最大工作压力	最大工作压力	最大工作压力
	ASME 150 磅级	ASME 300 磅级	ASME 600 磅级
	ASTM A216 Gr.WCB*		
°C	bar		
-29	19,6	51,1	102,1
50	19,2	50,1	100,2
100	17,7	46,6	93,2
150	15,8	45,1	90,2
200	13,8	43,8	87,6
250	12,1	41,9	83,9
300	10,2	39,8	79,6
350	8,4	37,6	75,1
400**	6,5	34,7	69,4
425**	5,5	28,8	57,5

*根据 ASME B16.34 - 材质组 1.1
**咨询工厂以选择适当的材质

温度	最大工作压力	最大工作压力	最大工作压力
	ASME 150 磅级	ASME 300 磅级	ASME 600 磅级
	ASTM A351 Gr.CF8M*		
°C	bar		
-60	19,0	49,6	99,3
-29	19,0	49,6	99,3
50	18,4	48,1	96,2
100	16,2	42,2	84,4
150	14,8	38,5	77,0
200	13,7	35,7	71,3
250	12,1	33,4	66,8
300	10,2	31,6	63,2
350	8,4	30,3	60,7
400**	6,5	29,4	58,9
450**	4,6	28,8	57,7
500**	2,8	28,2	56,5
538**	1,4	25,2	50,0

*根据 ASME B16.34 - 材质组 2.2
**咨询工厂以选择适当的材质

压力和温度
ASTM A216 Gr.WCB

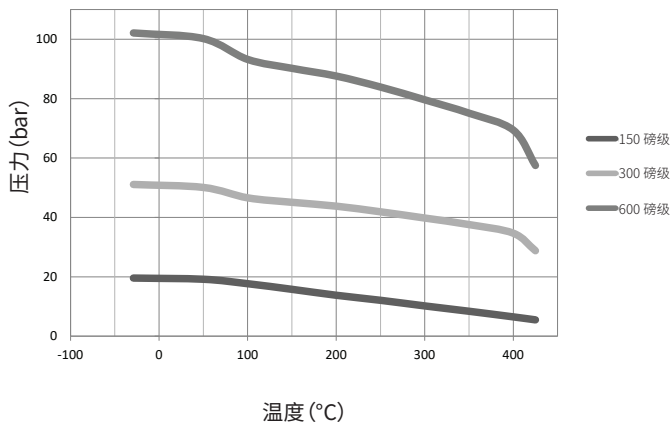

压力和温度
ASTM A351 Gr.CF8M

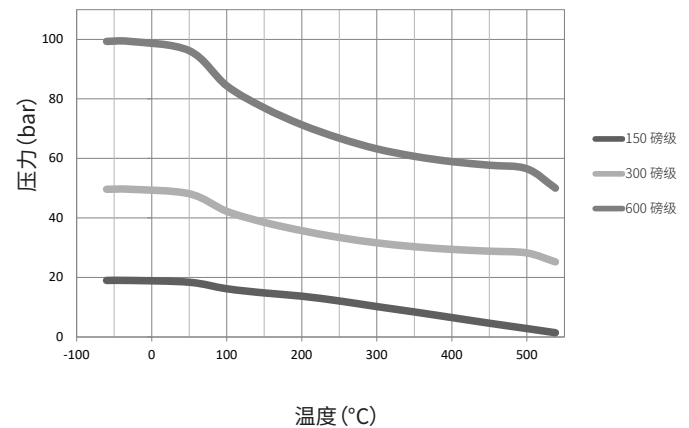

MAST 150 磅级

最大容许阀杆扭矩 (150 磅级)

代码		MAST [in-Lb]							
		阀杆材质							
DN	NPS	A	B	C	D	E	F	H	M
		ASTM A564 Gr. 630 (17-4PH)	ASTM A276 Gr. 431	ASTM A182 Gr. F55	ASTM A182 Gr. F51	ASTM A453 Gr. 660	ASTM A479 Gr. XM-19 (Nitronic 50)	ASTM UNS N06022 (Hastelloy C22)	ASTM B865 Monel K500
		1.4542	1.4057	1.4501	1.4462	1.4980	1.3964	2.4602	2.4375
150	6"	62592	51803	45758	38846	51803	31508	26765	59565
200	8"	62592	51803	45758	38846	51803	31508	26765	59565
250	10"	119511	98907	87365	74178	98907	60167	51104	113740
300	12"	198123	163968	144833	122972	163968	99747	84719	188564
350	14"	248023	205257	181315	153940	205257	124866	106049	236048
400	16"	312474	258600	228428	193945	258600	157312	133610	297384
450	18"	540309	447155	394989	335362	447155	272017	231030	514226
500	20"	540309	447155	394989	335362	447155	272017	231030	514226
600	24"	1051428	870148	768630	652615	870148	529343	449580	1000669
700	28"	如需尺寸 28"-36" / DN 700-900, 请咨询工厂							
750	30"								
800	32"								
900	36"								

代码		MAST [Nm]							
		阀杆材质							
DN	NPS	A	B	C	D	E	F	H	M
		ASTM A564 Gr. 630 (17-4PH)	ASTM A276 Gr. 431	ASTM A182 Gr. F55	ASTM A182 Gr. F51	ASTM A453 Gr. 660	ASTM A479 Gr. XM-19 (Nitronic 50)	ASTM UNS N06022 (Hastelloy C22)	ASTM B865 Monel K500
		1.4542	1.4057	1.4501	1.4462	1.4980	1.3964	2.4602	2.4375
150	6"	7072	5853	5170	4389	5853	3560	3024	6730
200	8"	7072	5853	5170	4389	5853	3560	3024	6730
250	10"	13503	11175	9871	8381	11175	6798	5774	12851
300	12"	22385	18526	16364	13894	18526	11270	9572	21305
350	14"	28023	23191	20486	17393	23191	14108	11982	26670
400	16"	35305	29218	25809	21913	29218	17774	15096	33600
450	18"	61047	50522	44628	37891	50522	30734	26103	58100
500	20"	61047	50522	44628	37891	50522	30734	26103	58100
600	24"	118796	98314	86844	73736	98314	59808	50796	113061
700	28"	如需尺寸 28"-36" / DN 700-900, 请咨询工厂							
750	30"								
800	32"								
900	36"								

最大容许阀杆扭矩 (300 磅级)

代码		MAST [in-Lb]							
		阀杆材质							
DN	NPS	A	B	C	D	E	F	H	M
		ASTM A564 Gr. 630 (17-4PH)	ASTM A276 Gr. 431	ASTM A182 Gr. F55	ASTM A182 Gr. F51	ASTM A453 Gr. 660	ASTM A479 Gr. XM-19 (Nitronic 50)	ASTM UNS N06022 (Hastelloy C22)	ASTM B865 Monel K500
		1.4542	1.4057	1.4501	1.4462	1.4980	1.3964	2.4602	2.4375
150	6"	62591	51800	45756	38850	51800	31511	26763	59569
200	8"	62591	51800	45756	38850	51800	31511	26763	59569
250	10"	119510	98905	87366	74178	98905	60167	51101	113740
300	12"	198126	163967	144837	122975	163967	99746	84716	188561
350	14"	248020	205258	181311	153944	205258	124865	106050	236047
400	16"	312471	258596	228427	193947	258596	157313	133608	297386
450	18"	540309	447152	394985	335364	447152	272018	231029	514225
500	20"	540309	447152	394985	335364	447152	272018	231029	514225
600	24"	1051432	870151	768633	652613	870151	529342	449578	1000673
700	28"	如需尺寸 28"-36"/ DN 700-900, 请咨询工厂							
750	30"								
800	32"								
900	36"								

代码		MAST [Nm]							
		阀杆材质							
DN	NPS	A	B	C	D	E	F	H	M
		ASTM A564 Gr. 630 (17-4PH)	ASTM A276 Gr. 431	ASTM A182 Gr. F55	ASTM A182 Gr. F51	ASTM A453 Gr. 660	ASTM A479 Gr. XM-19 (Nitronic 50)	ASTM UNS N06022 (Hastelloy C22)	ASTM B865 Monel K500
		1.4542	1.4057	1.4501	1.4462	1.4980	1.3964	2.4602	2.4375
150	6"	7072	5853	5170	4389	5853	3560	3024	6730
200	8"	7072	5853	5170	4389	5853	3560	3024	6730
250	10"	13503	11175	9871	8381	11175	6798	5774	12851
300	12"	22385	18526	16364	13894	18526	11270	9572	21305
350	14"	28023	23191	20486	17393	23191	14108	11982	26670
400	16"	35305	29218	25809	21913	29218	17774	15096	33600
450	18"	61047	50522	44628	37891	50522	30734	26103	58100
500	20"	61047	50522	44628	37891	50522	30734	26103	58100
600	24"	118796	98314	86844	73736	98314	59808	50796	113061
700	28"	如需尺寸 28"-36"/ DN 700-900, 请咨询工厂							
750	30"								
800	32"								
900	36"								

MAST 600 磅级

最大容许阀杆扭矩 (600 磅级)

代码		MAST [in-Lb]							
		阀杆材质							
DN	NPS	A	B	C	D	E	F	H	M
		ASTM A564 Gr. 630 (17-4PH)	ASTM A276 Gr. 431	ASTM A182 Gr. F55	ASTM A182 Gr. F51	ASTM A453 Gr. 660	ASTM A479 Gr. XM-19 (Nitronic 50)	ASTM UNS N06022 (Hastelloy C22)	ASTM B865 Monel K500
		1.4542	1.4057	1.4501	1.4462	1.4980	1.3964	2.4602	2.4375
150	6"	62591	51800	45756	38850	51800	31511	26763	59569
200	8"	198126	163967	144837	122975	163967	99746	84716	188561
250	10"	248020	205258	181311	153944	205258	124865	106050	236047
300	12"	363190	225428	265504	225428	300571	182847	155295	345657
350	14"	540309	447152	394985	335364	447152	272018	231029	514225
400	16"	741180	613390	541828	460043	613390	373146	316918	705399
450	18"	986073	816060	720853	612045	816060	496437	421631	938469
500	20"	1319974	1092392	964946	819294	1092392	664538	564403	1256251
600	24"	2145000	1775172	1568069	1331379	1775172	1079897	917172	2041448
700	28"	如需尺寸 28"-36" / DN 700-900, 请咨询工厂							
750	30"								
800	32"								
900	36"								

代码		MAST [Nm]							
		阀杆材质							
DN	NPS	A	B	C	D	E	F	H	M
		ASTM A564 Gr. 630 (17-4PH)	ASTM A276 Gr. 431	ASTM A182 Gr. F55	ASTM A182 Gr. F51	ASTM A453 Gr. 660	ASTM A479 Gr. XM-19 (Nitronic 50)	ASTM UNS N06022 (Hastelloy C22)	ASTM B865 Monel K500
		1.4542	1.4057	1.4501	1.4462	1.4980	1.3964	2.4602	2.4375
150	6"	7072	5853	5170	4389	5853	3560	3024	6730
200	8"	22385	18526	16364	13894	18526	11270	9572	21305
250	10"	28023	23191	20486	17393	23191	14108	11982	26670
300	12"	41035	25470	29998	25470	33960	20659	17546	39054
350	14"	61047	50522	44628	37891	50522	30734	26103	58100
400	16"	83743	69304	61219	51978	69304	42160	35807	79700
450	18"	111412	92203	81446	69152	92203	56090	47638	106033
500	20"	149138	123424	109025	92568	123424	75083	63769	141938
600	24"	242354	200569	177169	150426	200569	122013	103627	230654
700	28"	如需尺寸 28"-36" / DN 700-900, 请咨询工厂							
750	30"								
800	32"								
900	36"								

Kv / Cv 值 (150 磅级)

DN	NPS	开启角度	
		90°	
		Kv	Cv
150	6"	2276	2647
200	8"	4893	5689
250	10"	7565	8796
300	12"	11272	13107
350	14"	14766	17170
400	16"	19915	23157
450	18"	24894	28946
500	20"	31906	37100
600	24"	45798	53254
700	28"	如需尺寸 28"-36"/ DN 700-900, 请咨询 工厂	
750	30"		
800	32"		
900	36"		

Kv / Cv 值 (300 磅级)

DN	NPS	开启角度	
		90°	
		Kv	Cv
150	6"	2176	2530
200	8"	4874	5667
250	10"	7495	8715
300	12"	11165	12982
350	14"	14310	16639
400	16"	19647	22845
450	18"	22882	26607
500	20"	30186	35100
600	24"	44899	52208
700	28"	如需尺寸 28"-36"/ DN 700-900, 请咨询 工厂	
750	30"		
800	32"		
900	36"		

Kv / Cv 值 (600 磅级)

DN	NPS	开启角度	
		90°	
		Kv	Cv
150	6"	2219	2481
200	8"	4300	5000
250	10"	7093	8248
300	12"	9963	11585
350	14"	13198	15347
400	16"	18656	21693
450	18"	21586	25100
500	20"	27606	32100
600	24"	44309	51522
700	28"	如需尺寸 28"-36"/ DN 700-900, 请咨询 工厂	
750	30"		
800	32"		
900	36"		

150 磅级和 300 磅级的 CV 值按管径 40 算出
600 磅级的 CV 值按管径 80 算出

法兰螺栓连接

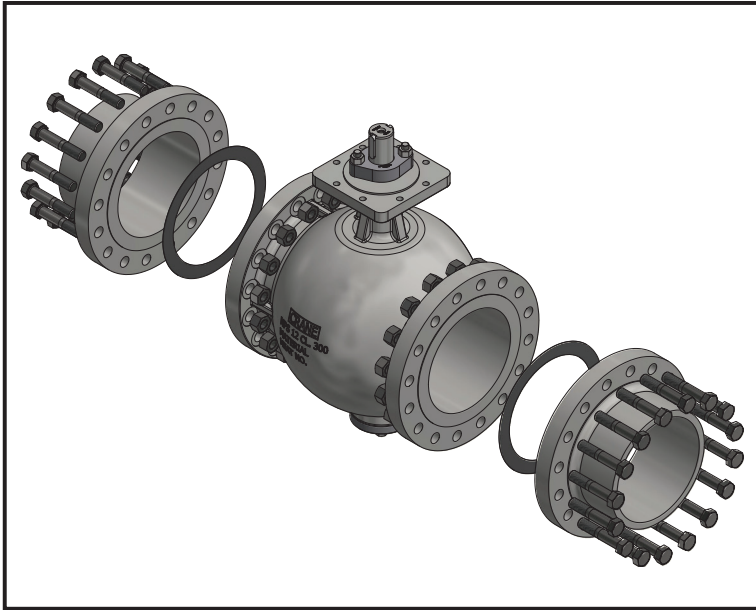

注：
 整个阀门所需的螺钉和螺母的数量
 对接法兰符合 AMSE B16.5 标准
 法兰垫圈厚度为 2 毫米
 螺钉符合 ASME B18.2.1 标准

150 磅级

DN	NPS	螺纹	L (轴侧)	数量	L (瓣侧)	数量	螺母数量
150	6"	3/4-10 UNC	3 1/4"	8	4 1/4"	8	16
200	8"	3/4-10 UNC	3 1/2"	8	4 3/4"	8	16
250	10"	7/8-9 UNC	3 3/4"	12	5 1/4"	12	24
300	12"	7/8-9 UNC	4"	12	5 1/2"	12	24
350	14"	1-8 UNC	4 1/4"	12	6"	12	24
400	16"	1-8 UNC	4 1/4"	16	6 1/4"	16	32
450	18"	1 1/8-8 UN	4 3/4"	16	6 1/2"	16	32
500	20"	1 1/8-8 UN	5"	20	7"	20	40
600	24"	1 1/4-8 UN	5 1/2"	20	7 1/2"	20	40
法兰凸面 RF 符合 ASME B16.47 系列 A 标准							
700	28"	如需尺寸 28"-36"/ DN 700-900, 请咨询工厂					
750	30"						
800	32"						
900	36"						

300 磅级

DN	NPS	螺纹	L (轴侧)	数量	螺母数量
150	6"	3/4-10 UNC	4 1/4"	24	24
200	8"	7/8-9 UNC	4 3/4"	24	24
250	10"	1-8 UNC	5 1/4"	32	32
300	12"	1 1/8-8 UN	5 1/2"	32	32
350	14"	1 1/8-8 UN	6"	40	40
400	16"	1 1/4-8 UN	6 1/4"	40	40
450	18"	1 1/4-8 UN	6 1/2"	48	48
500	20"	1 1/4-8 UN	7"	48	48
600	24"	1 1/2-8 UN	7 1/2"	48	48
法兰凸面 RF 符合 ASME B16.47 系列 A 标准					
700	28"	如需尺寸 28"-36"/ DN 700-900, 请咨询工厂			
750	30"				
800	32"				
900	36"				

600 磅级

DN	NPS	螺纹	L (轴侧)	数量	螺母数量
150	6"	1-8 UNC	3 3/4"	24	24
200	8"	1 1/8-8 UN	4 1/4"	24	24
250	10"	1 1/4-8 UN	4 1/2"	32	32
300	12"	1 1/4-8 UN	4 3/4"	40	40
350	14"	1 3/8-8 UN	5"	40	40
400	16"	1 1/2-8 UN	5 1/4"	40	40
450	18"	1 5/8-8 UN	5 3/2"	40	40
500	20"	1 5/8-8 UN	6"	48	48
600	24"	1 7/8-8 UN	6 3/4"	48	48
法兰凸面 RF 符合 ASME B16.47 系列 A 标准					
700	28"	如需尺寸 28"-36"/ DN 700-900, 请咨询工厂			
750	30"				
800	32"				
900	36"				

安装工具

DN	NPS	ISO 5211		安装工具
150 磅级		阀门	执行机构	产品编号
150	6"	F16	F10	MFSP1F10V022A
			F12	MFSP1F12V027A
			F14	MFSP1F14V036A
			F16	MFSP1F16V046A
			F25	MFSP1F25V055A
200	8"	F16	F12	MFTP1F12V027A
			F14	MFTP1F14V036A
			F16	MFTP1F16V046A
			F25	MFTP1F25V055A
250	10"	F16	F14	MFXUP1F14V036A
			F16	MFXUP1F16V046A
			F25	MFXUP1F25V055A
300	12"	F25	F12	MFVP1F12V027A
			F14	MFVP1F14V036A
			F16	MFVP1F16V046A
			F25	MFVP1F25V055A
			F30	MFVP1F30V075A
350	14"	F25	F16	MFWP1F16V046A
			F25	MFWP1F25V055A
			F30	MFWP1F30V075A
400	16"	F25	F14	MFXP1F14V036A
			F16	MFXP1F16V046A
			F25	MFXP1F25V055A
			F30	MFXP1F30V075A
450	18"	F30	F16	MFYP1F16V046A
			F25	MFYP1F25V055A
			F30	MFYP1F30V075A
500	20"	F30	F16	MFZN3F16V046A
			F25	MFZN3F25V055A
			F30	MFZN3F30V075A
600	24"	F35	F16	MFZN3F16V046A
			F25	MFZN3F25V055A
			F30	MFZN3F30V075A
			F35	MFZN3F35R120A
700	28"	如需尺寸 28"-36"/ DN 700-900, 请咨询工厂		
750	30"			
800	32"			
900	36"			

DN	NPS	ISO 5211		安装工具
300 磅级		阀门	执行机构	产品编号
150	6"	F16	F10	MFSP1F10V022A
			F12	MFSP1F12V027A
			F14	MFSP1F14V036A
			F16	MFSP1F16V046A
			F25	MFSP1F25V055A
200	8"	F16	F12	MFTP1F12V027A
			F14	MFTP1F14V036A
			F16	MFTP1F16V046A
			F25	MFTP1F25V055A
250	10"	F16	F14	MFXUP1F14V036A
			F16	MFXUP1F16V046A
			F25	MFXUP1F25V055A
300	12"	F25	F12	MFVP1F12V027A
			F14	MFVP1F14V036A
			F16	MFVP1F16V046A
			F25	MFVP1F25V055A
			F30	MFVP1F30V075A
350	14"	F25	F16	MFWP1F16V046A
			F25	MFWP1F25V055A
			F30	MFWP1F30V075A
400	16"	F25	F14	MFXP1F14V036A
			F16	MFXP1F16V046A
			F25	MFXP1F25V055A
			F30	MFXP1F30V075A
450	18"	F30	F16	MFYP1F16V046A
			F25	MFYP1F25V055A
			F30	MFYP1F30V075A
500	20"	F30	F16	MFZN3F16V046A
			F25	MFZN3F25V055A
			F30	MFZN3F30V075A
600	24"	F35	F16	MFZN3F16V046A
			F25	MFZN3F25V055A
			F30	MFZN3F30V075A
			F35	MFZN3F35R120A
700	28"	如需尺寸 28"-36"/ DN 700-900, 请咨询工厂		
750	30"			
800	32"			
900	36"			

DN	NPS	ISO 5211		安装工具
600 磅级		阀门	执行机构	产品编号
150	6"	F25	F16	MFXHR1F16V046A
			F25	MFXHR1F25V055A
			F30	MFXHR1F30V075A
200	8"	F25	F16	MFHTR1F16V046A
			F25	MFHTR1F25V055A
			F30	MFHTR1F30V075A
250	10"	F30	F25	MFHUR1F25V055A
			F30	MFHUR1F30V075A
			F35	MFHUR1F35R120A
300	12"	F30	F25	MFHVR1F25V055A
			F30	MFHVR1F30V075A
			F35	MFHVR1F35R120A
350	14"	F35	F30	MFHWR1F30V075A
			F35	MFHWR1F35R120A
			F40	MFHWR1F40R160A
400	16"	F35	F30	MFHXR1F30V075A
			F35	MFHXR1F35R120A
			F40	MFHXR1F40R160A
450	18"	F40	F30	MFHYR1F30V075A
			F35	MFHYR1F35R120A
			F40	MFHYR1F40R160A
			F48	MFHYR1F48R180A
500	20"	F48	F35	MFHZR1F35R120A
			F40	MFHZR1F40R160A
			F48	MFHZR1F48R180A
600	24"	F48	F35	MF2R1F35R120A
			F40	MF2R1F40R160A
			F48	MF2R1F48R180A
700	28"	如需尺寸 28"-36" / DN 700-900, 请咨询 工厂		
750	30"			
800	32"			
900	36"			

齿轮操作阀门的几何表

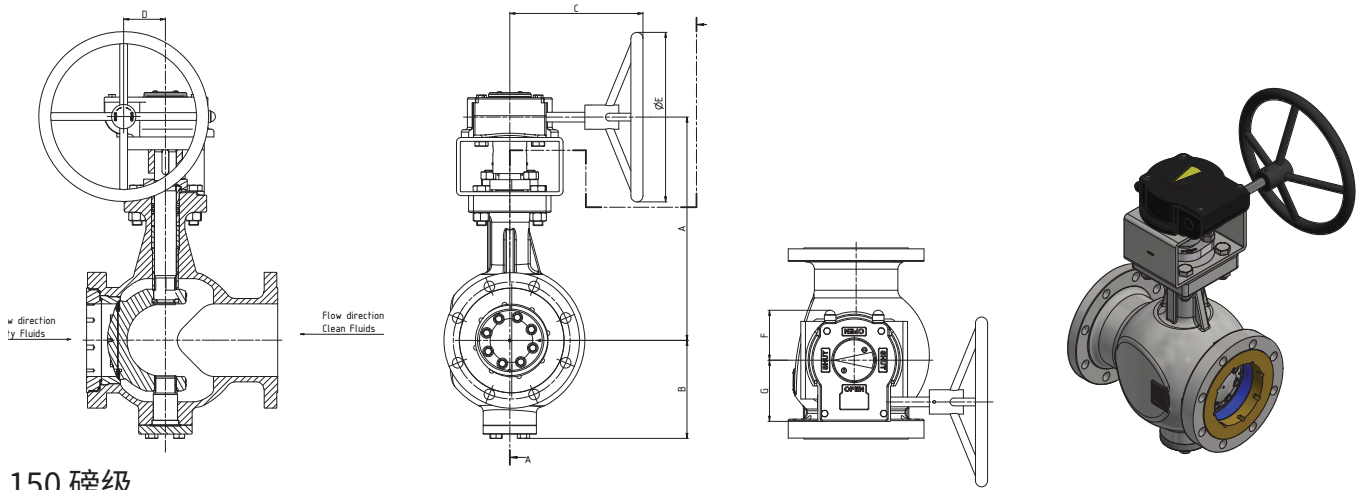

150 磅级

DN	NPS	尺寸 (英寸)							重量 (磅)
		A	B	C	D	øE	F	G	
150	6"	17.1	8.0	10.4	3.4	9.8	3.9	5.0	246
200	8"	18.1	9.4	10.8	3.4	13.8	3.9	5.0	373
250	10"	22.5	11.6	12.4	4.1	13.8	4.3	5.8	581
300	12"	25.3	13.3	13.6	4.1	19.7	4.3	5.8	918
350	14"	25.4	15.6	12.5	5.1	13.8	5.6	5.9	1196
400	16"	29.5	17.0	14.8	5.1	9.8	5.6	7.1	1553
450	18"	33.5	19.0	15.6	5.5	11.8	6.9	7.8	2071
500	20"	35.8	21.0	17.1	7.2	11.8	8.2	9.4	2723
600	24"	38.2	23.0	17.3	7.2	13.8	8.2	9.4	3985

300 磅级

DN	NPS	尺寸 (英寸)							重量 (磅)
		A	B	C	D	øE	F	G	
150	6"	17.1	8.0	10.4	3.4	9.8	3.9	5.0	407
200	8"	18.1	9.4	10.8	3.4	13.8	3.9	5.0	649
250	10"	22.5	11.6	12.4	4.1	13.8	4.3	5.8	1015
300	12"	25.3	13.3	13.6	4.1	19.7	4.3	5.8	1530
350	14"	25.4	15.6	12.5	5.1	13.8	5.6	5.9	1771
400	16"	29.5	17.0	14.8	5.1	9.8	5.6	7.1	2819
450	18"	33.5	19.0	15.6	5.5	11.8	6.9	7.8	4666
500	20"	35.8	21.0	17.1	7.2	11.8	8.2	9.4	5263
600	24"	38.2	23.0	17.3	7.2	13.8	8.2	9.4	10121

600 磅级

DN	NPS	尺寸 (英寸)							重量 (磅)
		A	B	C	D	øE	F	G	
150	6"	24.4	8.6	14.8	5.1	9.8	5.6	7.1	493
200	8"	26.5	11.4	15.6	5.5	11.8	6.9	7.8	876
250	10"	28.7	13.4	17.3	7.2	13.8	6.7	9.4	1332
300	12"	33.3	14.6	17.8	8.2	9.8	8.2	11.2	1939
350	14"	34.6	17.2	18.0	8.2	11.8	8.2	11.2	2218
400	16"	36.0	18.7	20.1	10.1	15.7	9.3	13.8	3174
450	18"	40.4	20.7	27.0	18.0	19.7	11.6	19.0	5866
500	20"	48.2	22.6	30.1	17.3	27.6	15.7	24.8	6732
600	24"	51.4	26.5	30.1	17.3	31.5	15.7	24.8	12923

齿轮操作阀门的几何表

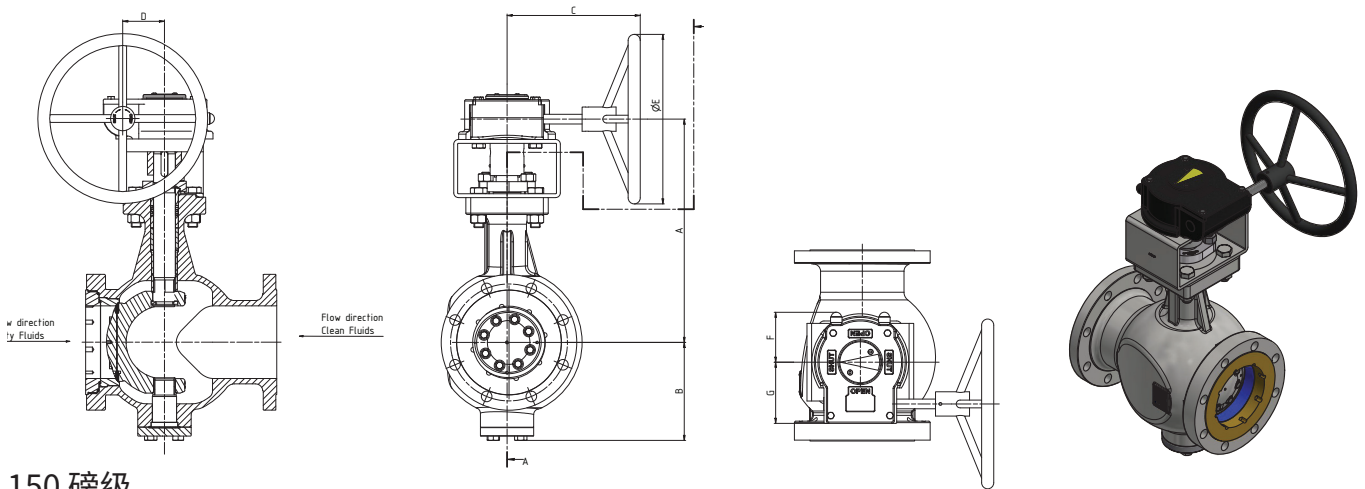

150 磅级

DN	NPS	尺寸(毫米)							重量(千克)
		A	B	C	D	øE	F	G	
150	6"	435	202	265	86	250	100	126	112
200	8"	460	239	275	86	350	100	126	169
250	10"	572	296	316	105	350	110	148	263
300	12"	642	339	346	105	500	110	148	416
350	14"	646	397	318	130	350	142	150	543
400	16"	750	433	377	130	250	143	180	705
450	18"	850	483	395	140	300	175	197	940
500	20"	910	533	435	182	300	208	238	1236
600	24"	970	583	440	182	350	208	238	1808

300 磅级

DN	NPS	尺寸(毫米)							重量(千克)
		A	B	C	D	øE	F	G	
150	6"	435	202	265	86	250	100	126	185
200	8"	460	239	275	86	350	100	126	294
250	10"	572	296	316	105	350	110	148	461
300	12"	642	339	346	105	500	110	148	694
350	14"	646	397	318	130	350	142	150	804
400	16"	750	433	377	130	250	143	180	1279
450	18"	850	483	395	140	300	175	197	2117
500	20"	910	533	435	182	300	208	238	2388
600	24"	970	583	440	182	350	208	238	4592

600 磅级

DN	NPS	尺寸(毫米)							重量(千克)
		A	B	C	D	øE	F	G	
150	6"	620	218	377	130	250	143	180	224
200	8"	674	290	395	140	300	175	197	398
250	10"	730	340	440	182	350	170	238	605
300	12"	845	372	451	209	250	208	284	880
350	14"	880	438	456	209	300	208	284	1007
400	16"	915	475	511	256	400	235	350	1440
450	18"	1025	525	687	458	500	295	483	2662
500	20"	1225	575	765	440	700	398	631	3055
600	24"	1305	674	765	440	800	398	631	5864

如需尺寸 28"-36"/ DN 700-900, 请咨询工厂

产品编码

产品系列		阀门类型			材质组		
阀门	尺寸	压力	阀体样式	主体材质	阀瓣材质	阀轴材质	

产品系列

阀门
FK-TriEX

阀门类型

尺寸		
150	6"	06
200	8"	08
250	10"	10
300	12"	12
350	14"	14
400	16"	16
450	18"	18
500	20"	20
600	24"	24
700	28"	28
750	30"	30
800	32"	32
900	36"	36

压力	
150 磅级	N
300 磅级	P
600 磅级	R

阀体样式	
双法兰 ASME B16.10 (球阀) 长型	DL

材质

主体材质	
ASTM A216 Gr.WCB 碳钢	A
ASTM A351 Gr.CF8M 不锈钢	B
ASTM A216 Gr.WCC 低合金钢	C
ASTM A352 Gr.LCB 低温碳钢	E
ASTM A352 Gr.LCC 低温碳钢	F
ASTM A216 Gr.WC6 低合金钢	G
ASTM A494 Gr.N7M Hastelloy B-2	H
ASTM A494 Gr.M30H Monel 500	M
ASTM A995 Gr.6A Superduplex	R
其他	X

阀瓣材质	
ASTM A216 Gr.WCB 碳钢	A
ASTM A351 Gr.CF8M 不锈钢	B
ASTM A216 Gr.WCC 低合金钢	C
ASTM A352 Gr.LCB 低温碳钢	E
ASTM A352 Gr.LCC 低温碳钢	F
ASTM A216 Gr.WC6 低合金钢	G
ASTM A494 Gr.N7M Hastelloy B-2	H
ASTM A494 Gr.M30H Monel 500	M
ASTM A995 Gr.6A Superduplex	R
其他	X

阀轴材质	
ASTM A564 Gr.630	A
ASTM 276 Gr.431	B
ASTM A182 Gr.F55	C
ASTM A182 Gr.F51	D
ASTM A453 Gr.660	E
ASTM A479 Gr.XM-19	F
ASTM UNS N06022	H
ASTM B865 Monel K500	M
其他	X

密封环/TriEX 阀座组合	
ASTM A240 UNS S31803/石墨, 层压, 阀座: Stellite 21	1
ASTM A240 UNS S31803, 层压 (可选配石墨), 阀座: Stellite 21	2
Hastelloy C276/石墨, 层压, 阀座: Stellite 21	4
Hastelloy C276, 层压 (可选配石墨) + Stellite 21	5
ASTM A240 UNS S31803/PTFE, 层压, 阀座: Stellite 21	6
Hastelloy C276/PTFE, 层压, 阀座: Stellite 21	7
Incoloy / 石墨, 阀座: Stellite 21	8
ASTM A240 Gr.321/石墨, 层压, 阀座: Stellite 21	A
ASTM A240 Gr.321, 层压 (可选配石墨), 阀座: Stellite 21	B
Incoloy 800H, 层压 (可选配石墨), 阀座: Stellite 21	C
Monel / 石墨	M
K500 Grade Monel 500 (ASTM)	N
其他	X

密封环/TrieX 阀座组合	法兰面	压盖/填料/限位开关选件			驱动	选件
	法兰类型	压盖填料	填料函	压盖法兰设计	操作类型	选件

法兰面

法兰类型	
平面 FF 符合 ANSI B16.5 标准 平面 FF 符合 ANSI B16.47 系列 A 标准	6
凸面 RF 符合 ANSI B16.5 标准 凸面 RF 符合 ANSI B16.47 系列 A 标准	A
大槽面 LGF 符合 ANSI B16.5 标准	L
其他	X

压盖/填料/限位开关选件

压盖填料	
标准石墨填料 (ISO 15848 AH CO3 / TA-Luft 和 API 641)	1
高温石墨填料 (TA-Luft)	5
高温石墨填料 (非 FE / 非 TA-Luft / EN12266 A / API598)	6

驱动

操作类型	
电气	E
裸轴	F
手动, 带齿轮	G
液压	H
安装工具	M
气动, 齿条和小齿轮	R
气动, 止转棒軛	Y
其他	X

填料函

单填料	A
带压紧轴承的单填料	G
带监测口和压紧轴承保护器的单填料	R
其他	X

压盖法兰类型

标准设计	A
其他	X

选件

选件	
Nace MR0175	不适用
温度高达 550°C	HT550
温度高达 700°C	HT700
所有内部组件均由 316 不锈钢制成	SS316
符合 DT91 标准	DT91 x 磅级
加热套	HJ
带有 CE 标志	CE
根据 EN15848-2 测试	EN 15848-2

CRANE[®]

**CRANE CHEMPHARMA &
ENERGY**

Friedrich Krombach GmbH
Armaturenwerke
Marburger Str.364
57223 Kreuztal, Germany
电话: +49 2732 520 00

4526 Research Forest Drive,
Suite 400
The Woodlands
Texas 77381, U.S.A.
电话: +1 936 271 6500

ARMATURE d.o.o.
Koro ka cesta 55
2366 Muta, Slovenia
电话: +386 2 87 70 500
quote-armature@cranecpe.com

Crane Co. 及其子公司对产品目录、手册、其他印刷品和网站信息中可能存在的错误不承担责任。Crane Co. 保留在不通知的情况下更改其产品的权利, 包括已经订购的产品, 前提是这种更改不需要对已经达成共识的规格进行更改。本资料中的所有商标都是 Crane Co. 或其子公司的财产。Crane 和 Crane 品牌的标志 (CENTER LINE[®]、COMPAC-NOZ[®]、CRANE[®]、DEPA[®] & ELRO[®]、DOPAK[®]、DUO-CHEK[®]、FLOWSEAL[®]、GYROLOK[®]、GO REGULATOR[®]、HOKE[®]、JENKINS[®]、KROMBACH[®]、NOZ-CHEK[®]、PACIFIC VALVES[®]、RESISTOFLEX[®]、REVO[®]、SAUNDERS[®]、STOCKHAM[®]、TEXAS SAMPLING[®]、TRIANGLE[®]、UNI-CHEK[®]、VALVES[®]、WESTLOCK CONTROLS[®]、WTA[®] 和 XOMOX[®]) 是 Crane Co. 的注册商标。保留所有权利。