



# TECHNICAL DATASHEET

## ASME DESIGN

**FULL PORT TRIPLE OFFSET VALVE WITH CAVITY FREE DESIGN THAT PROVIDES ZERO LEAKAGE SHUTOFF**

**CRANE® FK-TrieX™ Full Port**  
Full Port Triple Offset Isolation  
Valves For Severe Service

**CRANE**

 [www.cranecpe.com](http://www.cranecpe.com)

# Table of Content

Features and Benefits	3
Exploded View	4
Materials of Construction	5
Dimensions and Weights Class 150	6
Dimensions and Weights Class 300	10
Dimensions and Weights Class 600	14
Pressure/Temperature Ratings	18
MAST Class 150	20
MAST Class 300	21
MAST Class 600	22
Kv / Cv Values & Torques	23
Flange Bolting	24
Mounting Kits	26
Geometry Tables for Gear Operated Valves	28
Product Coding	32 - 33
Notes	35

## CRANE® FK-TRIEX™ Full Port Triple Offset Isolation Valves For Severe Service

CRANE® FK-TrieX™ an innovative quarter turn technology that provides unparalleled reliability with it's bidirectional shutoff, unobstructed flow and cavity free design, at low overall cost.

### STANDARD DESIGN

- Zero leakage per API 598
- Dimensional compliance to API 6D & piggable per section 6.2.1
- Cavity free self cleaning design
- Fugitive emissions control per ISO 15848-1 AH C02 & API 641
- Fire safe design per API 607
- ASME B16.10 Double flanged long - ball valve
- Removable seat and seal
- ISO 5211 integral mounting flange
- Single packing with pressure tight bearing

### OPTIONAL DESIGN

- Gear operator with hand wheel
- Pneumatic actuation with accessories (solenoid valve, limit switch, pressure regulator, manual override)
- Electric actuation
- Heating Jacket
- Design compliant to NACE MR0175 and NACE MR0103
- High temperature Graphite packing
- Single packing with Pressure Tight Bearing & Monitoring port
- Bearing protector for bottom stem
- Welded bottom cover for hazardous & toxic media
- Capping valve design
- Oil & grease free assembly
- Stem extension
- DT91 impact testing
- G93 certification for Oxygen service

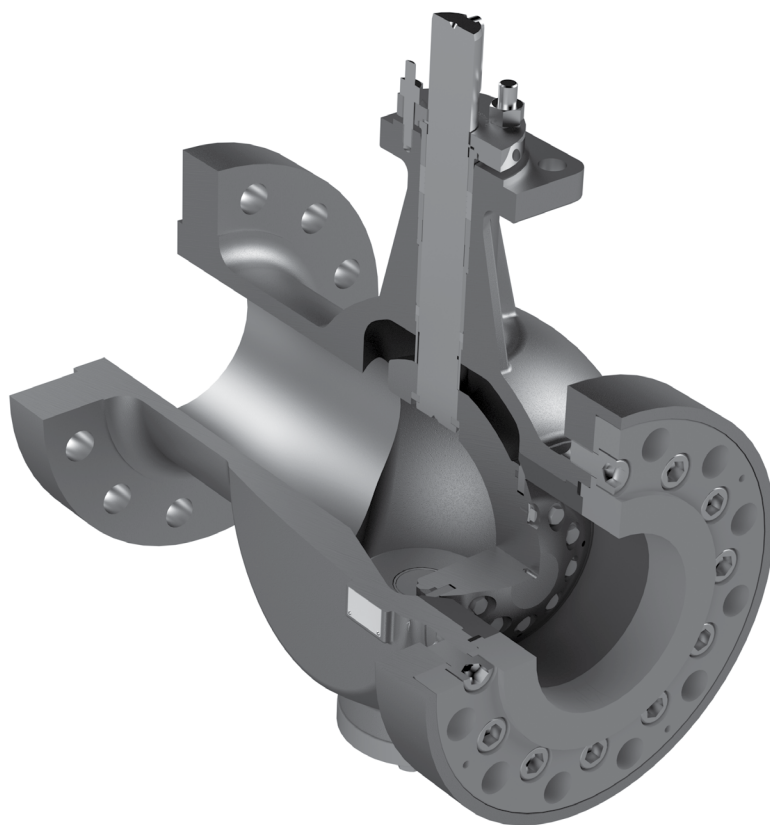

### Product Range

Size	Class	Body Design	Face-to-Face Dimension
3"-24"	Class 150-600	Single Piece Body Design Double Flanged Long	ASME B16.10 Long Pattern (Ball Valve)

# Exploded View

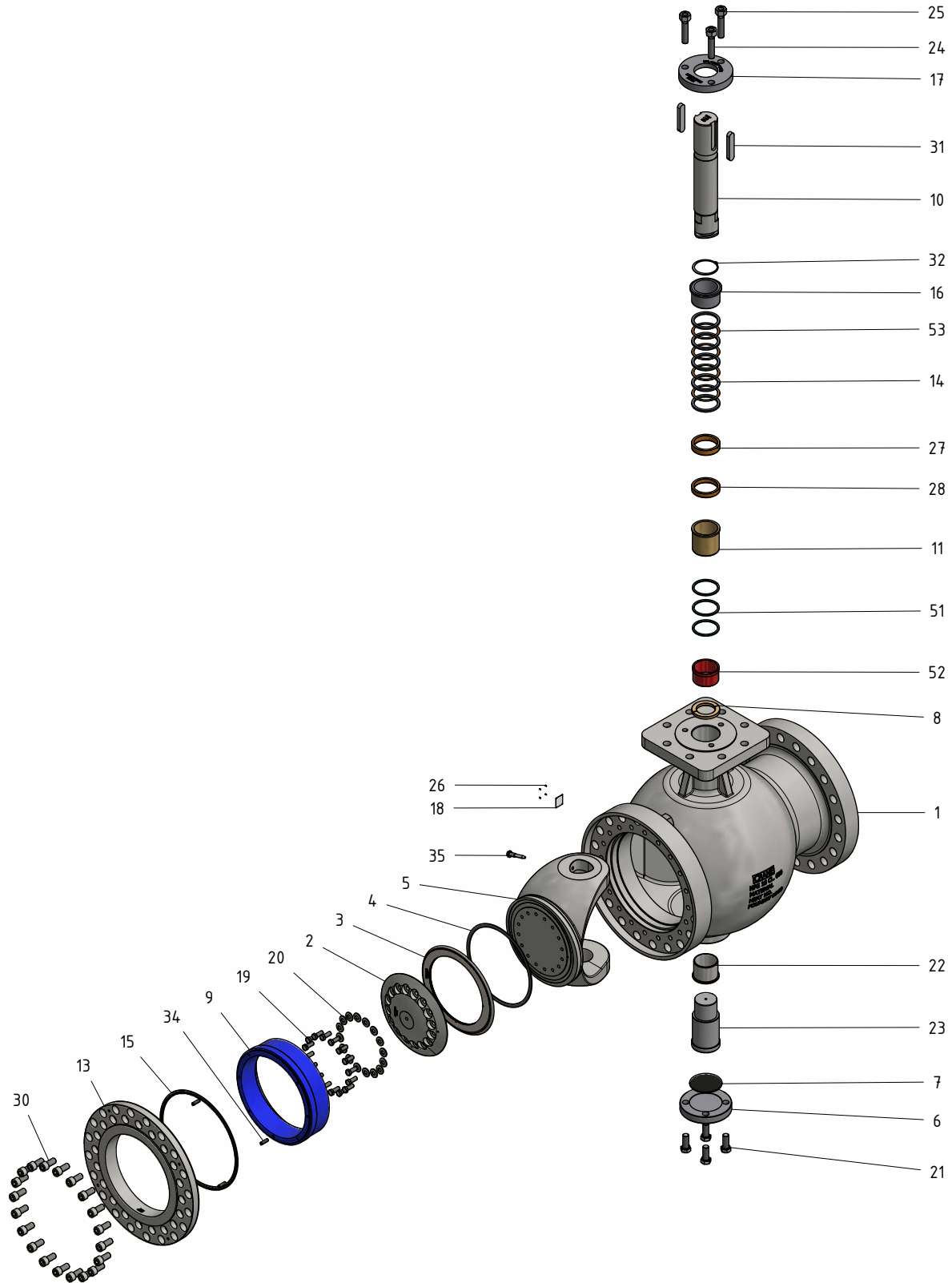

# Materials of Construction

Item	Description	Carbon Steel max. 700°F / 371°C*		Stainless Steel max. 700°F / 371°C*	
		ASTM	DIN	ASTM	DIN
1	Body	A216 Gr.WCB	1.0619	A351 Gr.CF8M	1.4408
2	Seal Retainer Ring	A515 Gr.60	1.0425	A240 Gr.321	1.4541
3	Laminated seal	Titanium Gr. 5/Graphite	3.7164/Graphite	Titanium Gr. 5/Graphite	3.7164/Graphite
4	SPW gasket	1.4404/Graphite			
5	Disc	A216 Gr.WCB	1.0619	A351 Gr.CF8M	1.4408
6	Cover	A516 Gr.60/A105	1.0425	A240 Gr.321	1.4541
7	Cover Gasket	Graphite			
8	Split Ring	A564 Gr.630 (17-4 PH)	1.4542	A564 Gr.630 (17-4 PH)	1.4542
9	Triex Ring	A105/A216 Gr.WCB	1.0482 / 1.0619	A182-F316/A351 Gr.CF8M	1.4408
10	Shaft	A564 Gr.630 (17-4 PH)	1.4542	A564 Gr.630 (17-4 PH)	1.4542
11	Bearing	A582 Gr.303 coated	1.4305 coated	A582 Gr.303 coated	1.4305 coated
13	L-ring Flange	A105/A216 Gr.WCB	1.0482 / 1.0619	A182-F316/A351 Gr.CF8M	1.4408
14	Packing	Graphite			
15	SW Gasket	1.4404/Graphite			
16	Gland	A582 Gr.303	1.4305	A582 Gr.303	1.4305
17	Gland Flange	A516 Gr.60	1.0425	A240 Gr.321	1.4541
18	Name Plate	A240 Gr. 304	1.4301	A240 Gr. 304	1.4301
19	Retainer Screw	A193 Gr.B8 Class 2	A4-70	A193 Gr.B8 Class 2	A4-70
20	Spring Washer	A4/ASTM 316			
21	Cover Screws	A193 Gr.B8 Class 2	A4-70	A193 Gr.B8 Class 2	A4-70
22	Disc bearing	A582 Gr.303 coated	1.4305 coated	A582 Gr.303 coated	1.4305 coated
23	Bottom shaft	A564 Gr.630 (17-4 PH)	1.4542	A564 Gr.630 (17-4 PH)	1.4542
24	Gland Stud	A193 Gr.B8 Class 2	A4-70	A193 Gr.B8 Class 2	A4-70
25	Gland Nut	A194 Gr.8	A4-70	A194 Gr.8	A4-70
26	Notched Nail	Steel Galvanised/A4	A4-70	Steel Galvanised/A4	A4-70
27	Upper Spacer	A582 Gr.304	1.4305	A582 Gr.304	1.4305
28	Lower Spacer	A582 Gr.304	1.4305	A582 Gr.304	1.4305
30	Socket head screws for L-ring	A4-70	A4-70	A4-70	A4-70
31	Drive key	A194 Gr.2	1.1191	A194 Gr.2	1.1191
32	Circlip	1.4310/1.4122/ASTM 301			
34	Dowel Pin	SS316	1.4401	SS316	1.4401
35	Threaded Pin	A193 Gr.B8	A4-70	A193 Gr.B8	A4-70
51	Packing Ring	Graphite			
52	Pressure Tight Bush	A582 Gr.304	1.4305	A582 Gr.304	1.4305
53	Diffusion Barrier	Graphite			

\* consult factory for higher temperatures

# Dimensions and Weights Class 150

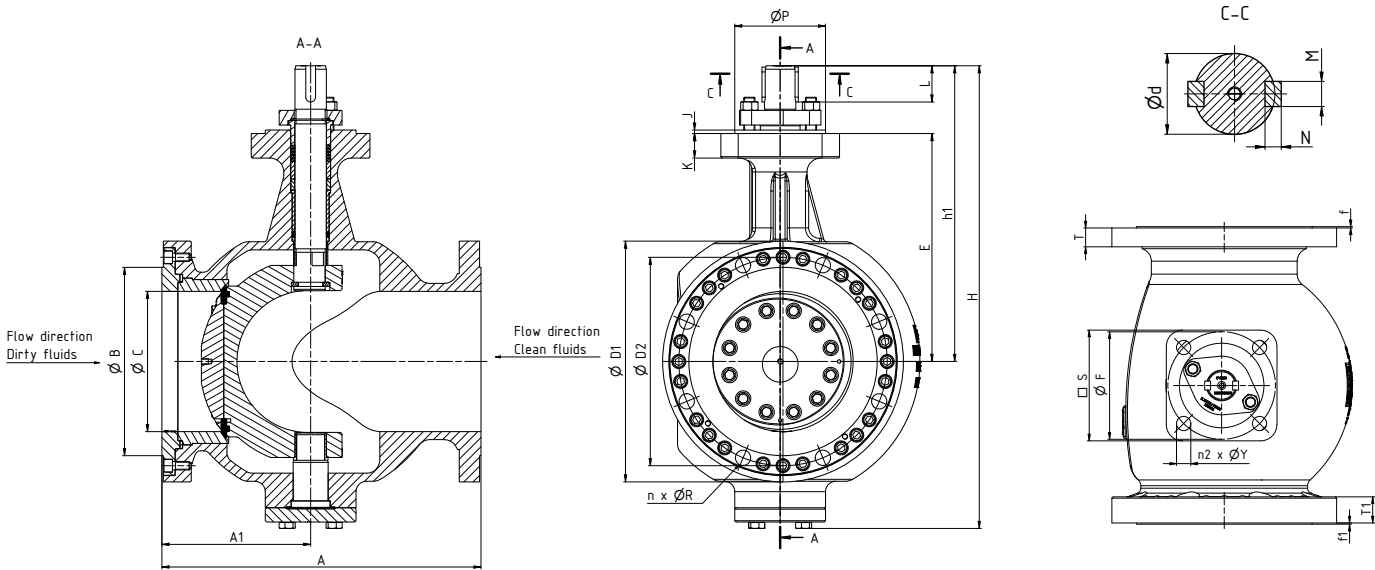

Class	NPS	Dimensions inch														
		A	$\varnothing C$	H	h1	E	$\varnothing D1$	$\varnothing D2$	n	$\varnothing R$	$\varnothing B$	T	f	T1	f1	A1
150	4"	9.016	3.937	18.543	12.205	8.622	9.055	7.500	8	0.748	6.189	0.866	0.079	1.228	0.079	4.689
150	6"	15.512	5.906	23.504	15.551	11.772	11.024	9.500	8	0.866	8.500	1.020	0.079	1.398	0.079	6.398
150	8"	17.992	7.913	26.102	16.683	12.854	13.583	11.752	8	0.875	10.626	1.142	0.079	1.516	0.079	8.386
150	10"	20.984	9.921	32.008	19.961	15.689	15.945	14.252	12	1.000	12.744	1.205	0.079	1.933	0.079	10.197
150	12"	24.016	11.929	37.008	22.874	17.480	19.094	17.000	12	1.000	14.995	1.268	0.079	2.020	0.079	12.028
150	14"	27.008	13.252	41.693	25.945	19.902	21.063	18.752	12	1.122	16.252	1.394	0.079	1.969	0.079	13.130
150	16"	30.000	15.252	44.370	27.047	21.004	23.425	21.252	16	1.126	18.500	1.457	0.079	2.268	0.079	14.311
150	18"	34.016	17.165	51.102	30.669	24.606	25.000	22.752	16	1.260	21.000	1.579	0.079	2.394	0.079	15.929
150	20"	35.984	19.173	56.339	34.567	27.165	27.559	25.000	20	1.260	23.000	1.705	0.079	2.559	0.079	17.819
150	24"	42.008	23.189	68.425	41.339	31.437	32.087	29.500	20	1.378	27.252	1.933	0.079	2.886	0.079	20.827

Class	NPS	Dimensions inch											
		ISO	S	$\varnothing P$	$\varnothing F$	n2	$\varnothing Y$	K	J	$\varnothing d$	L	M	N
150	4"	F16	6.693	5.118	6.496	4	0.866	1.378	0.197	1.772	2.047	0.551	0.354
150	6"	F16	6.693	5.118	6.496	4	0.866	1.378	0.197	1.772	2.047	0.551	0.354
150	8"	F16	6.693	5.118	6.496	4	0.866	1.378	0.197	1.772	2.047	0.551	0.354
150	10"	F16	6.299	5.118	6.496	4	0.866	1.220	0.197	2.165	2.283	0.630	0.394
150	12"	F25	10.630	7.874	10.000	8	0.689	1.319	0.197	2.559	2.835	0.709	0.433
150	14"	F25	11.024	7.874	10.000	8	0.689	1.299	0.197	2.953	2.835	0.787	0.472
150	16"	F25	11.024	7.874	10.000	8	0.669	1.280	0.197	2.953	3.150	0.787	0.472
150	18"	F30	12.756	9.055	11.732	8	0.866	1.587	0.197	3.543	3.681	0.984	0.551
150	20"	F30	13.780	9.055	11.732	8	0.866	1.496	0.197	3.543	4.921	0.984	0.551
150	24"	F35	16.142	10.236	14.016	8	1.299	2.146	0.394	4.331	6.299	1.102	0.630

# Dimensions and Weights Class 150

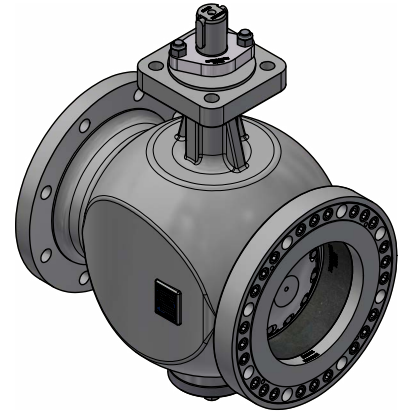
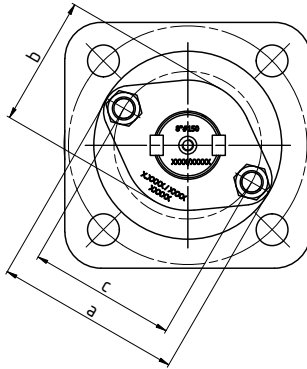
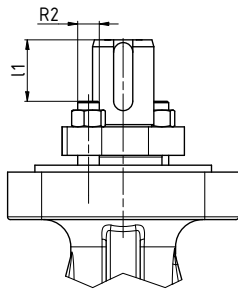

Class	NPS	Dimensions inch					Weight lb
		a CS*   SS*	b CS*   SS*	c	l1	R2	
150.0	4"	4.961	3.307	3.701	1.220	9/16-12 UNC	103.588
150.0	6"	5.079	3.543	4.016	1.732	5/8-11 UNC	190.712
150.0	8"	5.079	3.543	4.016	1.772	5/8-11 UNC	329.917
150.0	10"	5.079	3.543	3.858	2.008	5/8-11 UNC	506.347
150.0	12"	6.693	4.724	5.118	2.205	3/4-10 UNC	859.560
150.0	14"	7.795	5.512	5.906	2.205	1-8 UNC	1157.100
150.0	16"	7.795	5.512	5.906	2.205	1-8 UNC	1454.640
150.0	18"	8.937	-	7.028	2.165	1-8 UNC	2038.700
150.0	20"	8.937	-	7.028	3.465	1-8 UNC	2578.680
150.0	24"	10.157	-	8.031	5.630	1-1/8-8 UN	4308.820

# Dimensions and Weights Class 150

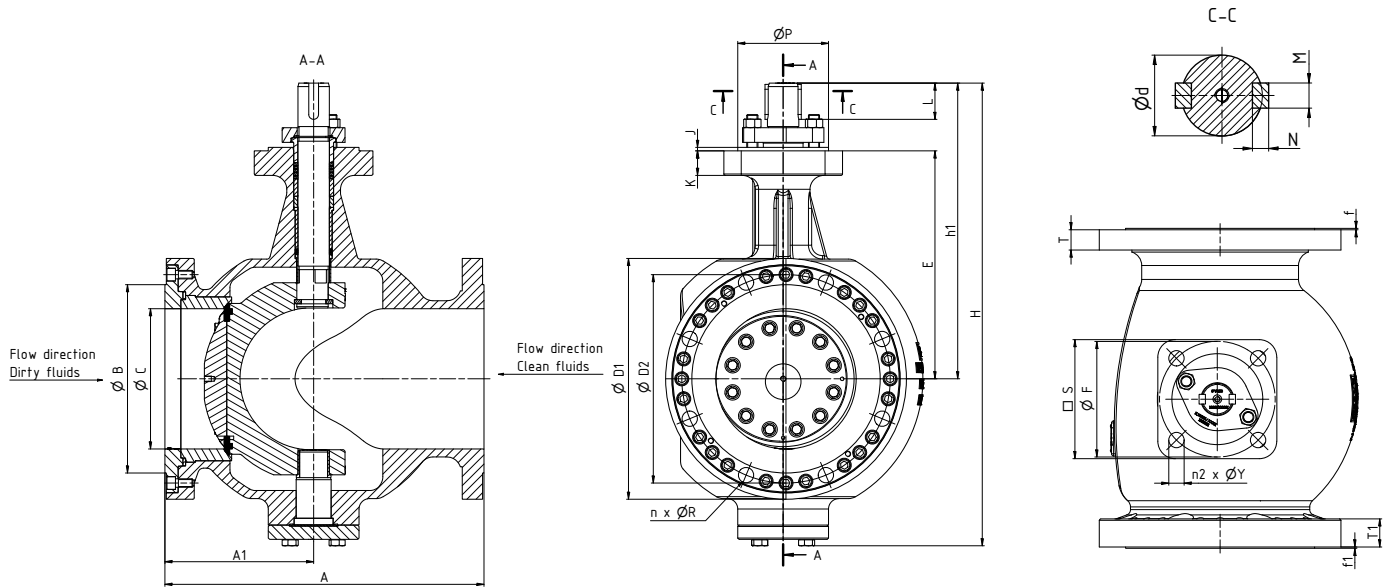

Class	NPS	Dimensions mm														
		A	$\varnothing C$	H	$h_1$	E	$\varnothing D1$	$\varnothing D2$	n	$\varnothing R$	$\varnothing B$	T	f	T1	f1	A1
150	4"	229.0	100.0	471.0	310.0	219.0	230.0	190.5	8.0	19.0	157.2	22.0	2.0	31.2	2.0	119.1
150	6"	394.0	150.0	597.0	395.0	299.0	280.0	241.3	8.0	22.0	215.9	25.9	2.0	35.5	2.0	162.5
150	8"	457.0	201.0	663.0	423.7	326.5	345.0	298.5	8.0	22.2	269.9	29.0	2.0	38.5	2.0	213.0
150	10"	533.0	252.0	813.0	507.0	398.5	405.0	362.0	12.0	25.4	323.7	30.6	2.0	49.1	2.0	259.0
150	12"	610.0	303.0	940.0	581.0	444.0	485.0	431.8	12.0	25.4	380.9	32.2	2.0	51.3	2.0	305.5
150	14"	686.0	336.6	1059.0	659.0	505.5	535.0	476.3	12.0	28.5	412.8	35.4	2.0	50.0	2.0	333.5
150	16"	762.0	387.4	1127.0	687.0	533.5	595.0	539.8	16.0	28.6	469.9	37.0	2.0	57.6	2.0	363.5
150	18"	864.0	436.0	1298.0	779.0	625.0	635.0	577.9	16.0	32.0	533.4	40.1	2.0	60.8	2.0	404.6
150	20"	914.0	487.0	1431.0	878.0	690.0	700.0	635.0	20.0	32.0	584.2	43.3	2.0	65.0	2.0	452.6
150	24"	1067.0	589.0	1738.0	1050.0	798.5	815.0	749.3	20.0	35.0	692.2	49.1	2.0	73.3	2.0	529.0

Class	NPS	Dimensions mm											
		ISO	S	$\varnothing P$	$\varnothing F$	n2	$\varnothing Y$	K	J	$\varnothing d$	L	M	N
150	4"	F16	160.0	130.0	165.0	4.0	21.0	23.0	5.0	40.0	46.0	12.0	8.0
150	6"	F16	170.0	130.0	165.0	4.0	22.0	35.0	5.0	45.0	52.0	14.0	9.0
150	8"	F16	170.0	130.0	165.0	4.0	22.0	35.0	5.0	45.0	52.0	14.0	9.0
150	10"	F16	160.0	130.0	165.0	4.0	22.0	31.0	5.0	55.0	58.0	16.0	10.0
150	12"	F25	270.0	200.0	254.0	8.0	17.5	33.5	5.0	65.0	72.0	18.0	11.0
150	14"	F25	280.0	200.0	254.0	8.0	17.5	33.0	5.0	75.0	72.0	20.0	12.0
150	16"	F25	280.0	200.0	254.0	8.0	17.0	32.5	5.0	75.0	80.0	20.0	12.0
150	18"	F30	324.0	230.0	298.0	8.0	22.0	40.3	5.0	90.0	93.5	25.0	14.0
150	20"	F30	350.0	230.0	298.0	8.0	22.0	38.0	5.0	90.0	125.0	25.0	14.0
150	24"	F35	410.0	260.0	356.0	8.0	33.0	54.5	10.0	110.0	160.0	28.0	16.0

## Dimensions and Weights Class 150

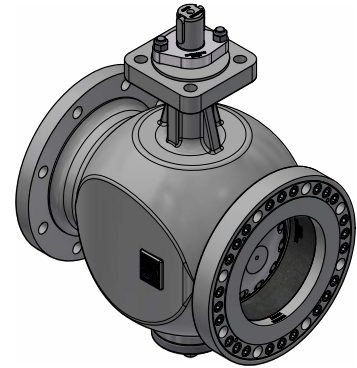
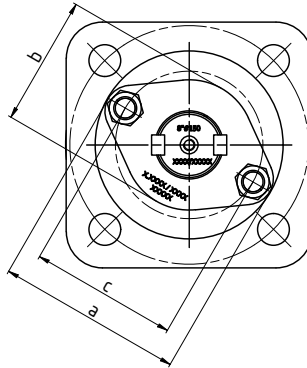
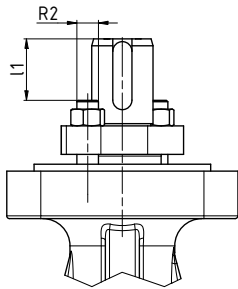

Class	NPS	Dimensions mm					Weight kg
		a	b	c	l1	R2	
150	4"	126.0	84.0	94.0	31.0	5/8-11 UNC	47
150	6"	129.0	90.0	102.0	44.0	5/8-11 UNC	87
150	8"	129.0	90.0	102.0	45.0	5/8-11 UNC	150
150	10"	129.0	90.0	98.0	51.0	5/8-11 UNC	230
150	12"	170.0	120.0	130.0	56.0	3/4-10 UNC	390
150	14"	198.0	140.0	150.0	56.0	1-8 UNC	525
150	16"	198.0	140.0	150.0	56.0	1-8 UNC	660
150	18"	227.0	-	178.5	55.0	1-8 UNC	925
150	20"	227.0	-	178.5	88.0	1-8 UNC	1170
150	24"	258.0	-	204.0	143.0	1-1/8 - 8 UN	1955

# Dimensions and Weights Class 300

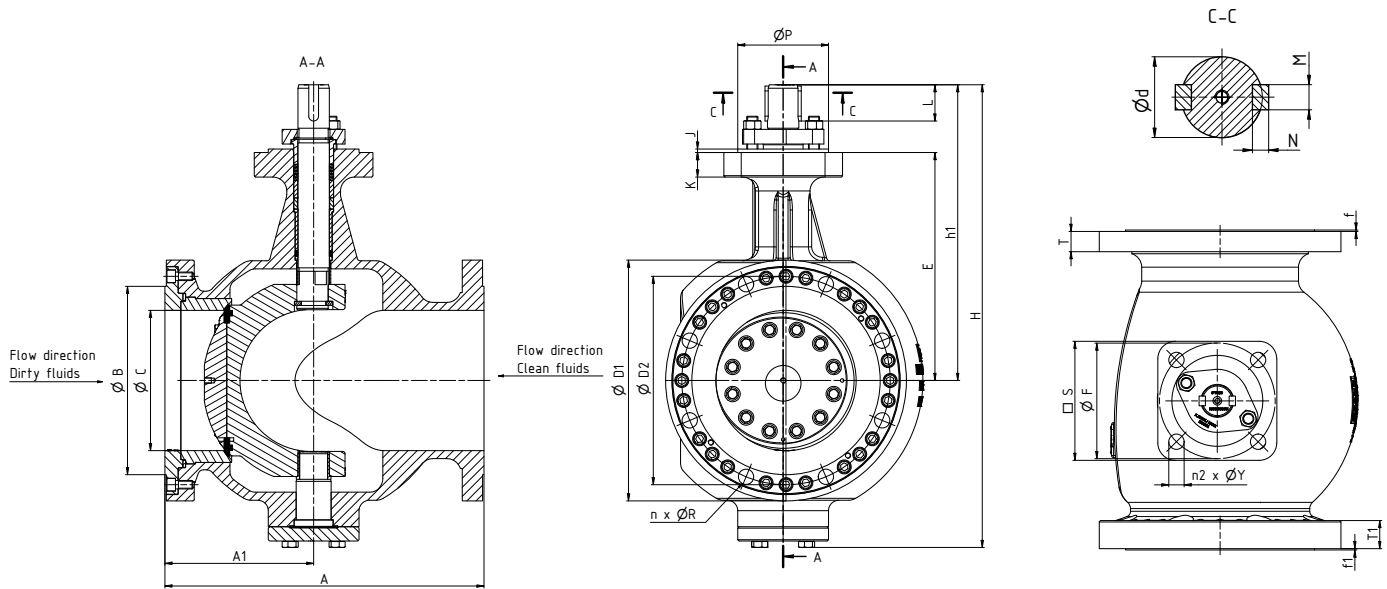

Class	NPS	Dimensions inch												
		A	øC	H	h1	E	øD1	øD2	n	øR	øB	T	f	A1
300	3"	11.142	2.913	17.441	11.378	8.071	8.268	6.626	8	0.886	5.000	1.063	0.079	5.122
300	4"	12.008	3.937	18.622	12.008	8.622	10.039	7.874	8	0.886	6.189	1.189	0.079	5.374
300	6"	15.866	5.992	23.465	15.472	11.811	12.598	10.626	12	0.866	8.500	1.457	0.079	6.398
300	8"	19.764	7.913	26.063	16.614	12.953	14.961	13.000	12	0.965	10.626	1.642	0.079	8.346
300	10"	22.362	9.921	32.008	19.961	15.689	17.520	15.252	16	1.126	12.748	1.894	0.079	10.236
300	12"	25.512	11.929	37.008	22.874	17.480	20.472	17.748	16	1.250	15.000	2.020	0.079	11.890
300	14"	30.000	13.252	41.701	25.945	19.902	23.031	20.252	20	1.260	16.245	2.142	0.079	12.736
300	16"	32.992	15.244	44.386	27.055	21.004	25.591	22.500	20	1.378	18.500	2.268	0.079	14.311
300	18"	35.984	17.165	51.102	30.669	24.606	27.953	24.748	24	1.378	21.000	2.394	0.079	16.516
300	20"	39.016	19.173	56.339	34.567	27.165	30.512	27.000	24	1.378	23.000	2.520	0.079	17.937
300	24"	45.000	23.189	68.425	41.339	31.437	36.024	32.000	24	1.626	27.252	2.768	0.079	21.811

Class	NPS	Dimensions inch											
		ISO	S	øP	øF	n2	øY	K	J	ød	L	M	N
300	3"	F14	5.118	3.937	5.512	4	0.689	0.748	0.197	1.378	1.575	0.394	0.315
300	4"	F16	6.299	5.118	6.496	4	0.827	0.906	0.197	1.575	1.811	0.472	0.315
300	6"	F16	6.693	5.118	6.496	4	0.866	1.378	0.197	1.772	2.047	0.551	0.354
300	8"	F17	6.299	5.118	6.496	4	0.866	1.378	0.197	1.772	2.047	0.551	0.354
300	10"	F18	6.299	5.118	6.496	4	0.866	1.220	0.197	2.165	2.283	0.630	0.394
300	12"	F19	10.630	7.874	10.000	8	0.689	1.319	0.197	2.559	2.835	0.709	0.433
300	14"	F20	11.024	7.874	10.000	8	0.689	1.299	0.197	2.953	2.835	0.787	0.472
300	16"	F21	11.024	7.874	10.000	8	0.669	1.280	0.197	2.953	3.150	0.787	0.472
300	18"	F22	12.756	9.055	11.732	8	0.827	1.587	0.197	3.543	3.681	0.984	0.551
300	20"	F23	16.339	10.236	14.016	8	1.299	1.724	0.197	3.543	4.921	0.984	0.551
300	24"	F24	18.701	11.811	15.984	8	1.535	2.067	0.394	4.331	6.299	1.102	0.630

## Dimensions and Weights Class 300

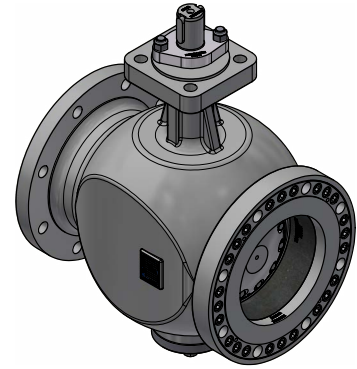
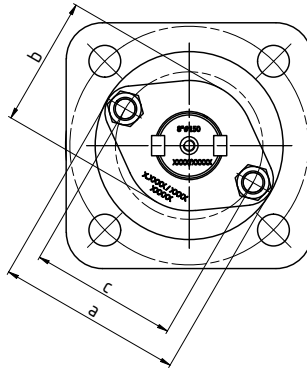
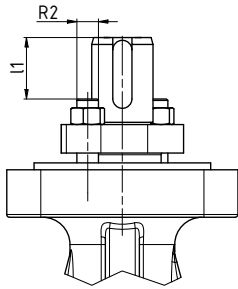

Class	NPS	Dimensions inch					Weight lb
		a CS*   SS*	b CS*   SS*	c	l1	R2	
300	3"	3.858	2.559	2.913	1.457	9/16-12 UNC	92.568
300	4"	4.961	3.307	3.701	1.024	9/16-12 UNC	132.240
300	6"	5.079	3.543	4.016	1.220	5/8-11 UNC	242.440
300	8"	5.079	3.543	4.016	1.299	5/8-11 UNC	407.740
300	10"	5.079	3.543	3.858	2.047	5/8-11 UNC	628.140
300	12"	6.693	4.724	5.118	2.205	3/4-10 UNC	1013.840
300	14"	7.795	5.512	5.906	1.929	1-8 UNC	1399.540
300	16"	7.795	5.512	5.906	1.929	1-8 UNC	1785.240
300	18"	8.858	-	7.028	2.126	1-8 UNC	2545.620
300	20"	8.858	-	7.028	3.465	1-8 UNC	3328.040
300	24"	10.157	-	8.031	5.472	1-8 UNC	5267.560

# Dimensions and Weights Class 300

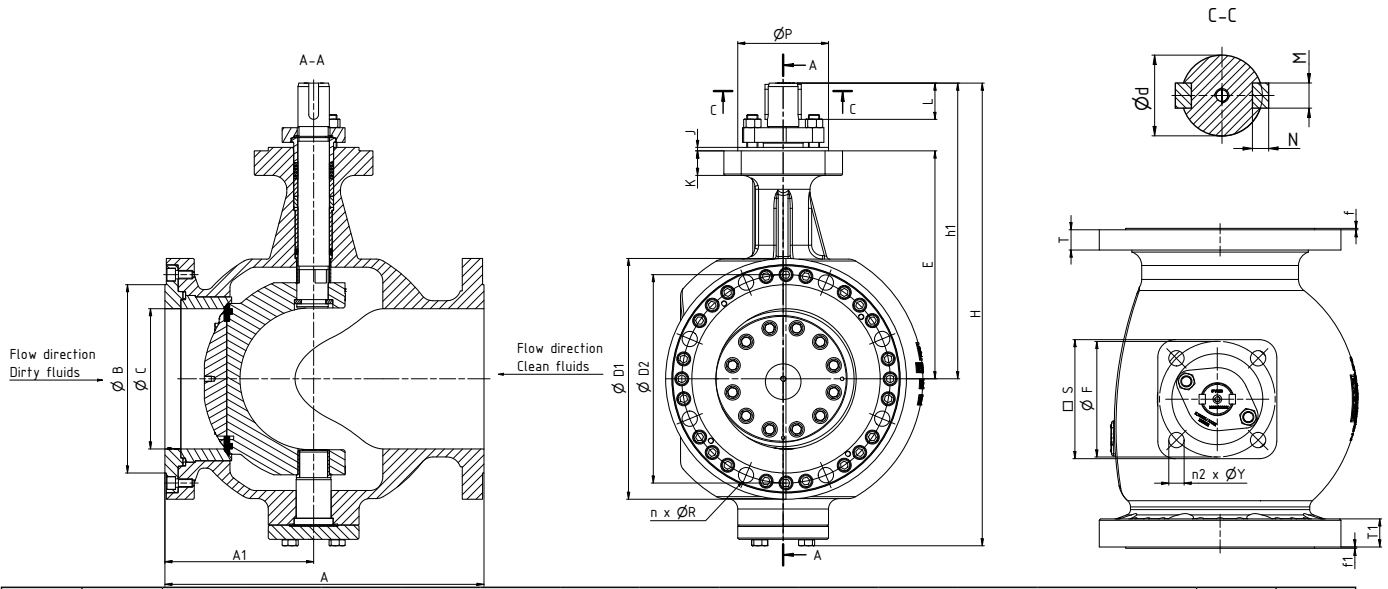

Class	NPS	Dimensions mm														
		A	$\varnothing C$	H	$h_1$	E	$\varnothing D1$	$\varnothing D2$	n	$\varnothing R$	$\varnothing B$	T	f	T1	f1	A1
300	3"	283.0	74.0	443.0	289.0	205.0	210.0	168.3	8.0	22.5	127.0	27.0	2.0	30.0	2.0	130.1
300	4"	305.0	100.0	473.0	305.0	219.0	255.0	200.0	8.0	22.5	157.2	30.2	2.0	32.2	2.0	136.5
300	6"	403.0	152.2	596.0	393.0	300.0	320.0	269.9	12.0	22.0	215.9	37.0	2.0	38.0	2.0	162.5
300	8"	502.0	201.0	662.0	422.0	329.0	380.0	330.2	12.0	24.5	269.9	41.7	2.0	42.7	2.0	212.0
300	10"	568.0	252.0	813.0	507.0	398.5	445.0	387.4	16.0	28.6	323.8	48.1	2.0	49.1	2.0	260.0
300	12"	648.0	303.0	940.0	581.0	444.0	520.0	450.8	16.0	31.8	381.0	51.3	2.0	52.3	2.0	302.0
300	14"	762.0	336.6	1059.2	659.0	505.5	585.0	514.4	20.0	32.0	412.6	54.4	2.0	55.4	2.0	323.5
300	16"	838.0	387.2	1127.4	687.2	533.5	650.0	571.5	20.0	35.0	469.9	57.6	2.0	58.6	2.0	363.5
300	18"	914.0	436.0	1298.0	779.0	625.0	710.0	628.6	24.0	35.0	533.4	60.8	2.0	61.8	2.0	419.5
300	20"	991.0	487.0	1431.0	878.0	690.0	775.0	685.8	24.0	35.0	584.2	64.0	2.0	67.0	2.0	455.6
300	24"	1143.0	589.0	1738.0	1050.0	798.5	915.0	812.8	24.0	41.3	692.2	70.3	2.0	73.3	2.0	554.0

Class	NPS	Dimensions mm											
		ISO	S	$\varnothing P$	$\varnothing F$	n2	$\varnothing Y$	K	J	$\varnothing d$	L	M	N
300	3"	F14	130.0	100.0	140.0	4.0	17.5	19.0	5.0	35.0	40.0	10.0	8.0
300	4"	F16	160.0	130.0	165.0	4.0	21.0	23.0	5.0	40.0	46.0	12.0	8.0
300	6"	F16	170.0	130.0	165.0	4.0	22.0	35.0	5.0	45.0	52.0	14.0	9.0
300	8"	F16	160.0	130.0	165.0	4.0	22.0	35.0	5.0	45.0	52.0	14.0	9.0
300	10"	F16	160.0	130.0	165.0	4.0	22.0	31.0	5.0	55.0	58.0	16.0	10.0
300	12"	F25	270.0	200.0	254.0	8.0	17.5	33.5	5.0	65.0	72.0	18.0	11.0
300	14"	F25	280.0	200.0	254.0	8.0	17.5	33.0	5.0	75.0	72.0	20.0	12.0
300	16"	F25	280.0	200.0	254.0	8.0	17.0	32.5	5.0	75.0	80.0	20.0	12.0
300	18"	F30	324.0	230.0	298.0	8.0	21.0	40.3	5.0	90.0	93.5	25.0	14.0
300	20"	F30	415.0	260.0	356.0	8.0	33.0	43.8	5.0	90.0	125.0	25.0	14.0
300	24"	F40	475.0	300.0	406.0	8.0	39.0	52.5	10.0	110.0	160.0	28.0	16.0

## Dimensions and Weights Class 300

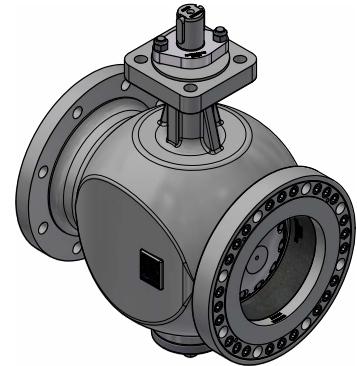
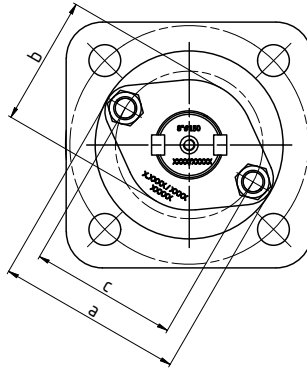
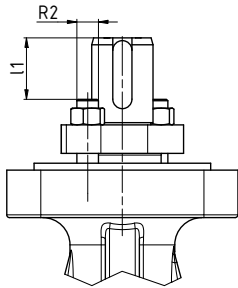

Class	NPS	Dimensions mm					Weight kg
		a	b	c	l1	R2	
300	3"	98.0	65.0	74.0	37.0	9/16-12 UNC	42
300	4"	126.0	84.0	94.0	26.0	9/16-12 UNC	60
300	6"	129.0	90.0	102.0	31.0	5/8-11 UNC	110
300	8"	129.0	90.0	102.0	33.0	5/8-11 UNC	185
300	10"	129.0	90.0	98.0	52.0	5/8-11 UNC	285
300	12"	170.0	120.0	130.0	56.0	3/4-10 UNC	460
300	14"	198.0	140.0	150.0	49.0	1-8 UNC	635
300	16"	198.0	140.0	150.0	49.0	1-8 UNC	810
300	18"	225.0	-	178.5	54.0	1-8 UNC	1155
300	20"	225.0	-	178.5	88.0	1-8 UNC	1510
300	24"	258.0	-	204.0	139.0	1-8 UNC	2390

# Dimensions and Weights Class 600

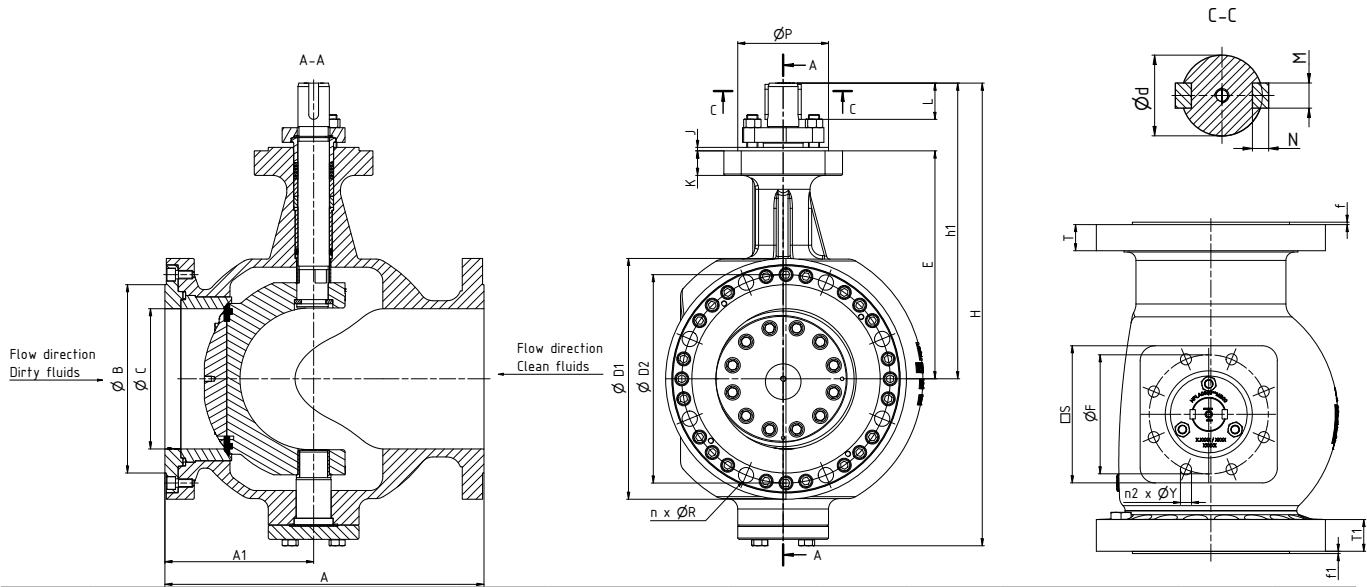

Class	NPS	Dimensions inch												
		A	øC	H	h1	E	øD1	øD2	n	øR	øB	T	f	A1
600	3"	14.016	2.913	17.992	11.890	8.504	8.268	6.626	8	0.886	5.000	1.291	0.276	5.138
600	4"	17.008	3.937	22.205	14.882	10.433	10.827	8.500	8	1.000	6.189	1.555	0.276	6.476
600	6"	22.008	6.000	25.000	16.378	12.126	13.976	11.500	12	1.122	8.500	1.957	0.276	8.484
600	8"	25.984	7.913	31.496	20.098	14.803	16.535	13.748	12	1.260	10.626	2.228	0.276	10.138
600	10"	30.984	9.921	37.402	23.976	17.835	20.079	17.000	16	1.378	12.748	2.579	0.276	12.028
600	12"	32.992	11.929	41.535	26.417	19.902	22.047	19.252	20	1.378	15.000	2.705	0.276	13.425
600	14"	35.000	12.862	44.843	27.559	20.079	23.819	20.748	20	1.496	16.252	2.795	0.276	13.327
600	16"	39.016	15.157	49.724	30.866	22.933	26.969	23.748	20	1.614	18.500	3.079	0.276	16.398
600	18"	42.992	17.165	57.126	36.063	26.319	29.331	25.748	20	1.772	21.000	3.331	0.276	18.602
600	20"	47.008	19.173	61.496	38.268	28.287	32.087	28.500	24	1.732	23.000	3.579	0.276	19.567
600	24"	55.000	22.079	68.937	42.378	29.724	37.008	33.000	24	2.008	27.252	4.134	0.276	20.689

Class	NPS	Dimensions inch											
		ISO	S	øP	øF	n2	øY	K	J	ød	L	M	N
600	3"	F14	5.118	3.937	5.512	4	0.689	0.906	0.197	1.575	1.772	0.472	0.315
600	4"	F16	6.299	5.118	6.614	4	0.827	0.984	0.197	1.772	2.480	0.551	0.354
600	6"	F16	6.299	5.118	6.496	4	0.866	0.984	0.197	1.969	2.480	0.551	0.354
600	8"	F25	11.811	7.874	10.000	8	0.689	1.535	0.197	2.559	3.543	0.709	0.433
600	10"	F30	13.780	9.055	11.732	8	0.866	1.772	0.197	2.756	3.937	0.787	0.472
600	12"	F30	13.780	9.055	11.732	8	0.866	1.594	0.197	3.150	3.937	0.866	0.551
600	14"	F30	13.780	9.055	11.732	8	0.866	1.575	0.197	3.543	4.921	0.984	0.551
600	16"	F35	16.142	10.236	14.016	8	1.299	2.106	0.197	3.937	5.512	1.102	0.630
600	18"	F40	16.339	10.236	14.016	8	1.535	2.323	0.197	4.331	6.299	1.102	0.630
600	20"	F48	18.701	11.811	15.984	8	1.535	2.343	0.394	4.724	7.087	1.260	0.709
600	24"	F48	22.047	14.567	19.016	12	1.535	2.835	0.394	5.512	8.661	1.417	0.787

# Dimensions and Weights Class 600

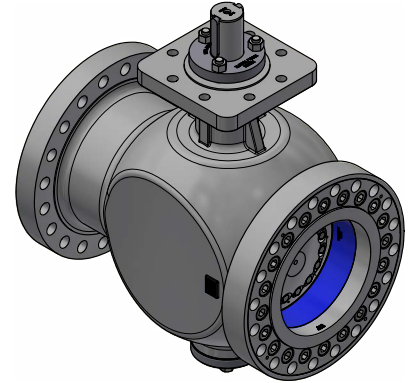
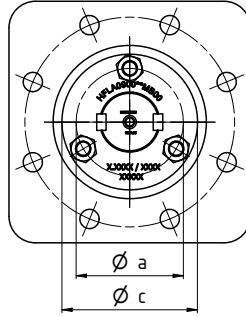
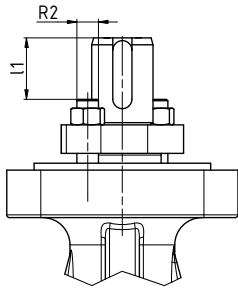

Class	NPS	Dimensions inch					Weight lb
		a CS*   SS*	b CS*   SS*	c	l1	R2	
600	3"	3.898	-	2.992	1.614	7/16-14 UNC	103.588
600	4"	4.803	-	3.701	1.929	9/16-12 UNC	202.768
600	6"	4.803	-	3.701	2.000	9/16-12 UNC	368.068
600	8"	5.906	-	4.646	3.224	5/8-11 UNC	694.260
600	10"	6.772	-	5.276	3.347	3/4-10 UNC	1135.060
600	12"	8.268	-	6.378	3.510	1-8 UNC	1531.780
600	14"	8.661	-	6.772	3.837	1-8 UNC	1776.424
600	16"	9.055	-	7.165	4.694	1-8 UNC	2680.064
600	18"	11.102	-	8.740	5.837	1 1/4-8 UN	3702.720
600	20"	11.024	-	8.740	5.429	1 1/4-8 UN	4815.740
600	24"	13.150	-	10.394	8.980	1 1/2-8 UN	6986.680

# Dimensions and Weights Class 600

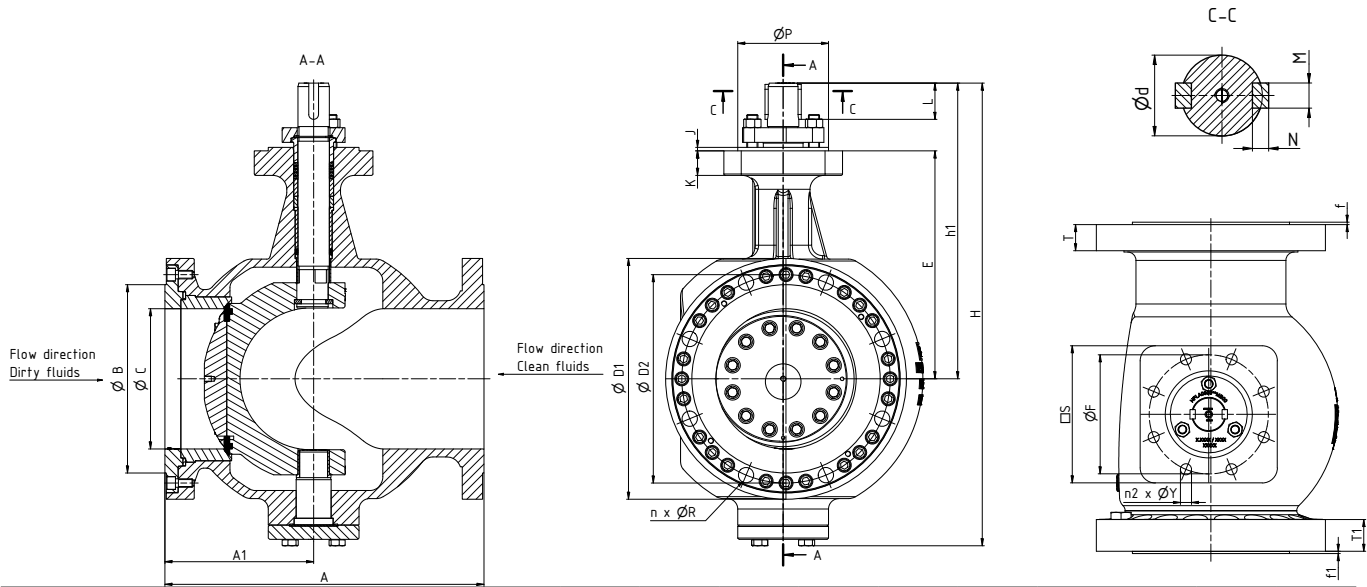

Class	NPS	Dimensions mm														
		A	øC	H	h1	E	øD1	øD2	n	øR	øB	T	f	T1	f1	A1
600	3"	356.0	74.0	457.0	302.0	216.0	210.0	168.3	8	22.5	127.0	32.8	7.0	32.8	7.0	130.5
600	4"	432.0	100.0	564.0	378.0	265.0	275.0	215.9	8	25.4	157.2	39.5	7.0	41.1	7.0	164.5
600	6"	559.0	152.4	635.0	416.0	308.0	355.0	292.1	12	28.5	215.9	49.7	7.0	50.7	7.0	215.5
600	8"	660.0	201.0	800.0	510.5	376.0	420.0	349.2	12	32.0	269.9	56.6	7.0	58.6	7.0	257.5
600	10"	787.0	252.0	950.0	609.0	453.0	510.0	431.8	16	35.0	323.8	65.5	7.0	66.5	7.0	305.5
600	12"	838.0	303.0	1055.0	671.0	505.5	560.0	489.0	20	35.0	381.0	68.7	7.0	69.7	7.0	341.0
600	14"	889.0	326.7	1139.0	700.0	510.0	605.0	527.0	20	38.0	412.8	71.0	7.0	72.0	7.0	338.5
600	16"	991.0	385.0	1263.0	784.0	582.5	685.0	603.2	20	41.0	469.9	78.2	7.0	79.2	7.0	416.5
600	18"	1092.0	436.0	1451.0	916.0	668.5	745.0	654.0	20	45.0	533.4	84.6	7.0	85.6	7.0	472.5
600	20"	1194.0	487.0	1562.0	972.0	718.5	815.0	723.9	24	44.0	584.2	90.9	7.0	93.9	7.0	497.0
600	24"	1397.0	560.8	1751.0	1076.4	755.0	940.0	838.2	24	51.0	692.2	105.0	7.0	104.0	7.0	525.5

Class	NPS	Dimensions mm											
		ISO	S	øP	øF	n2	øY	K	J	ød	L	M	N
600	3"	F14	130.0	100.0	140.0	4	17.5	23.0	5.0	40.0	45.0	12.0	8.0
600	4"	F16	160.0	130.0	168.0	4	21.0	25.0	5.0	45.0	63.0	14.0	9.0
600	6"	F16	160.0	130.0	165.0	4	22.0	25.0	5.0	50.0	63.0	14.0	9.0
600	8"	F25	300.0	200.0	254.0	8	17.5	39.0	5.0	65.0	90.0	18.0	11.0
600	10"	F30	350.0	230.0	298.0	8	22.0	45.0	5.0	70.0	100.0	20.0	12.0
600	12"	F30	350.0	230.0	298.0	8	22.0	40.5	5.0	80.0	100.0	22.0	14.0
600	14"	F30	350.0	230.0	298.0	8	22.0	40.0	5.0	90.0	125.0	25.0	14.0
600	16"	F35	410.0	260.0	356.0	8	33.0	53.5	5.0	100.0	140.0	28.0	16.0
600	18"	F40	415.0	260.0	356.0	8	39.0	59.0	5.0	110.0	160.0	28.0	16.0
600	20"	F40	475.0	300.0	406.0	8	39.0	59.5	10.0	120.0	180.0	32.0	18.0
600	24"	F48	560.0	370.0	483.0	12	39.0	72.0	10.0	140.0	220.0	36.0	20.0

# Dimensions and Weights Class 600

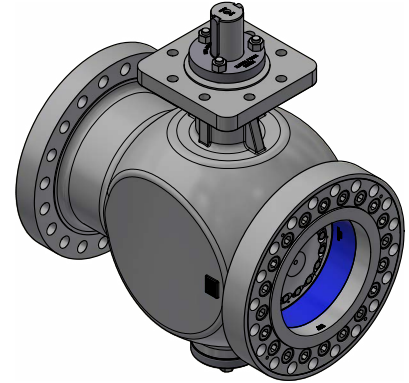
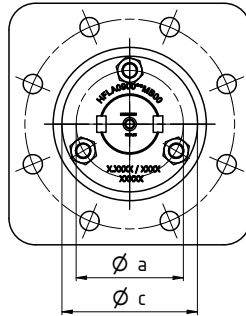
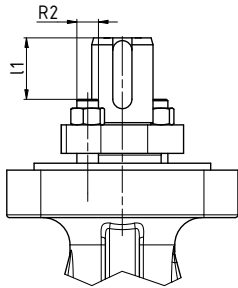

Class	NPS	Dimensions mm					Weight kg
		a	b	c	l1	R2	
600	3"	99.0	-	76.0	41.0	7/16-14 UNC	47.0
600	4"	122.0	-	94.0	49.0	9/16-12 UNC	92.0
600	6"	122.0	-	94.0	49.0	9/16-12 UNC	167.0
600	8"	150.0	-	118.0	79.0	5/8-11 UNC	315.0
600	10"	172.0	-	134.0	82.0	3/4-10 UNC	515.0
600	12"	210.0	-	162.0	86.0	1-8 UNC	695.0
600	14"	220.0	-	172.0	94.0	1-8 UNC	806.0
600	16"	230.0	-	182.0	115.0	1-8 UNC	1216.0
600	18"	282.0	-	222.0	143.0	1 1/4-8 UN	1680.0
600	20"	280.0	-	222.0	133.0	1 1/4-8 UN	2185.0
600	24"	334.0	-	264.0	220.0	1 1/2-8 UN	3170.0

# Pressure/Temperature Ratings

Temperature	Max working pressure ASME class 150	Max working pressure ASME class 300	Max working pressure ASME class 600
	ASTM A216 Gr. WCB*		
°F	psi		
-20	285	740	1480
100	285	740	1480
200	260	680	1360
300	230	655	1310
400	200	635	1265
500	170	605	1205
600	140	570	1135
650	125	550	1100
700	110	530	1060
750**	95	505	1015
800**	80	410	825

\*according ASME B16.34 - Material Group 1.1

\*\* Consult factory for appropriate material selection

Temperature	Max working pressure ASME class 150	Max working pressure ASME class 300	Max working pressure ASME class 600
	ASTM A351 Gr. CF8M*		
°F	psi		
-76	275	720	1440
-20	275	720	1440
100	275	720	1440
200	235	620	1240
300	215	560	1120
400	195	515	1025
500	170	480	955
600	140	450	900
650	125	440	885
700**	110	435	870
750**	95	425	855
800**	80	420	845
850**	65	420	835
900**	50	415	830
950**	35	385	775
1000**	20	365	725

\*according ASME B16.34 - Material Group 2.2

\*\* Consult factory for appropriate material selection

**Pressure & Temperature**  
ASTM A216 Gr. WCB

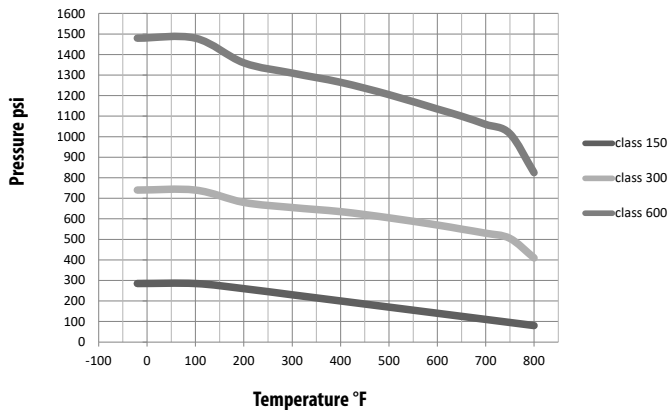

**Pressure & Temperature**  
ASTM A351 Gr. CF8M

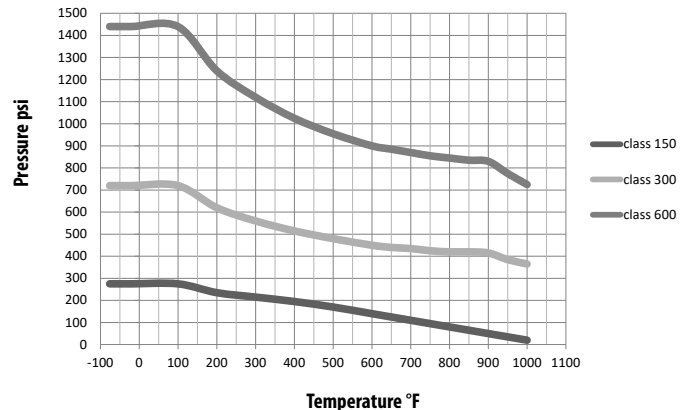

# Pressure/Temperature Ratings

Temperature	Max working pressure ASME class 150	Max working pressure ASME class 300	Max working pressure ASME class 600
	ASTM A216 Gr. WCB*		
°C	bar		
-29	19,6	51,1	102,1
50	19,2	50,1	100,2
100	17,7	46,6	93,2
150	15,8	45,1	90,2
200	13,8	43,8	87,6
250	12,1	41,9	83,9
300	10,2	39,8	79,6
350	8,4	37,6	75,1
400**	6,5	34,7	69,4
425**	5,5	28,8	57,5

\*according ASME B16.34 - Material Group 1.1  
 \*\* Consult factory for appropriate material selection

Temperature	Max working pressure ASME class 150	Max working pressure ASME class 300	Max working pressure ASME class 600
	ASTM A351 Gr. CF8M*		
°C	bar		
-60	19,0	49,6	99,3
-29	19,0	49,6	99,3
50	18,4	48,1	96,2
100	16,2	42,2	84,4
150	14,8	38,5	77,0
200	13,7	35,7	71,3
250	12,1	33,4	66,8
300	10,2	31,6	63,2
350	8,4	30,3	60,7
400**	6,5	29,4	58,9
450**	4,6	28,8	57,7
500**	2,8	28,2	56,5
538**	1,4	25,2	50,0

\*according ASME B16.34 - Material Group 2.2  
 \*\* Consult factory for appropriate material selection

**Pressure & Temperature  
ASTM A216 Gr. WCB**

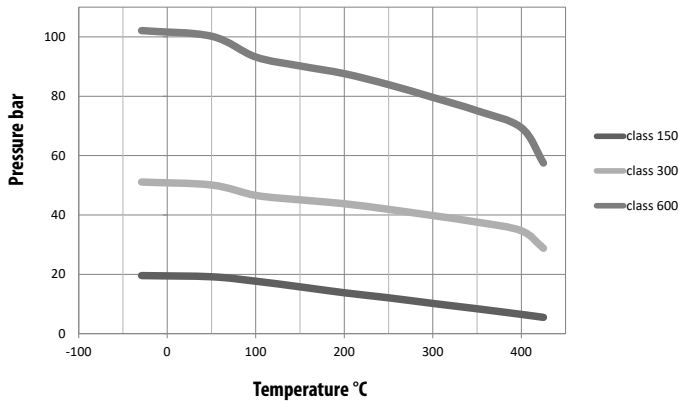

**Pressure & Temperature  
ASTM A351 Gr. CF8M**

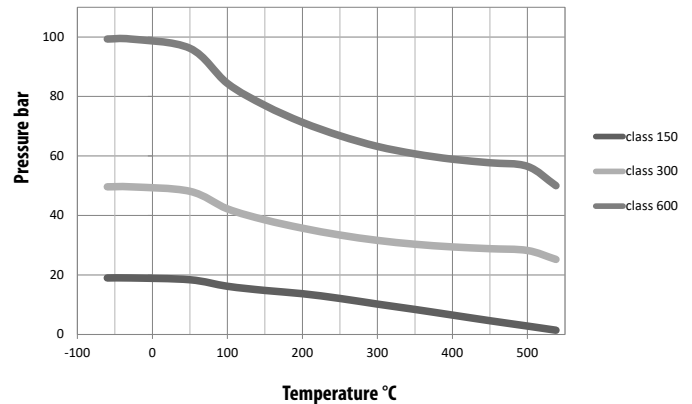

# MAST Class 150

## Maximum Allowable Stem Torque Class 150

Code		MAST [in-Lb]								
		Stem Material								
Class	NPS	ASTM A564 Gr. 630 (17-4PH)	ASTM A276 Gr. 431	ASTM A182 Gr. F55	ASTM A182 Gr. F51	ASTM A453 Gr. 660	ASTM A479 Gr. XM-19 (Nitronic 50)	ASTM UNS N06022 (Hastelloy C22)	ASTM B865 Monel K500	ASTM B 637 UNS N07718 Inconel 718
		1.4542	1.4057	1.4501	1.4462	1.4980	1.3964	2.4602	2.4375	
150	4"	28207	23339	20613	17498	23334	14193	12056	26831	40250
150	6"	62592	51803	45758	38846	51803	31508	26765	59565	89356
150	8"	62592	51803	45758	38846	51803	31508	26765	59565	89356
150	10"	119511	98907	87365	74178	98907	60167	51104	113740	170612
150	12"	198123	163968	144833	122972	163968	99747	84719	188564	282838
150	14"	248023	205257	181315	153940	205257	124866	106049	236048	354074
150	16"	312474	258600	228428	193945	258600	157312	133610	297384	446084
150	18"	540309	447155	394989	335362	447155	272017	231030	514226	771337
150	20"	540309	447155	394989	335362	447155	272017	231030	514226	771337
150	24"	1051428	870148	768630	652615	870148	529343	449580	1000669	1501004

Code		MAST [Nm]								
		Stem Material								
Class	NPS	ASTM A564 Gr. 630 (17-4PH)	ASTM A276 Gr. 431	ASTM A182 Gr. F55	ASTM A182 Gr. F51	ASTM A453 Gr. 660	ASTM A479 Gr. XM-19 (Nitronic 50)	ASTM UNS N06022 (Hastelloy C22)	ASTM B865 Monel K500	ASTM B 637 UNS N07718 Inconel 718
		1.4542	1.4057	1.4501	1.4462	1.4980	1.3964	2.4602	2.4375	
150	4"	3187	2637	2329	1977	2636	1604	1362	3031	4548
150	6"	7072	5853	5170	4389	5853	3560	3024	6730	10096
150	8"	7072	5853	5170	4389	5853	3560	3024	6730	10096
150	10"	13503	11175	9871	8381	11175	6798	5774	12851	19277
150	12"	22385	18526	16364	13894	18526	11270	9572	21305	31957
150	14"	28023	23191	20486	17393	23191	14108	11982	26670	40005
150	16"	35305	29218	25809	21913	29218	17774	15096	33600	50401
150	18"	61047	50522	44628	37891	50522	30734	26103	58100	87150
150	20"	61047	50522	44628	37891	50522	30734	26103	58100	87150
150	24"	118796	98314	86844	73736	98314	59808	50796	113061	169592

# MAST Class 300

## Maximum Allowable Stem Torque Class 300

		MAST [in-Lb]								
		Stem Material								
Code		A	B	C	D	E	F	H	M	N
Class	NPS	ASTM A564 Gr. 630 (17-4PH)	ASTM A276 Gr. 431	ASTM A182 Gr. F55	ASTM A182 Gr. F51	ASTM A453 Gr. 660	ASTM A479 Gr. XM-19 (Nitronic 50)	ASTM UNS N06022 (Hastelloy C22)	ASTM B865 Monel K500	ASTM B 637 UNS N07718 Inconel 718
		1.4542	1.4057	1.4501	1.4462	1.4980	1.3964	2.4602	2.4375	
300	3"	16276	13468	11895	10097	13462	8190	6956	15482	23223
300	4"	28207	23339	20613	17498	23330	14193	12054	26830	40245
300	6"	62591	51800	45756	38850	51800	31511	26763	59569	89354
300	8"	62591	51800	45756	38850	51800	31511	26763	59569	89354
300	10"	119510	98905	87366	74178	98905	60167	51101	113740	170610
300	12"	198126	163967	144837	122975	163967	99746	84716	188561	282842
300	14"	248020	205258	181311	153944	205258	124865	106050	236047	354070
300	16"	312471	258596	228427	193947	258596	157313	133608	297386	446079
300	18"	540309	447152	394985	335364	447152	272018	231029	514225	771338
300	20"	540309	447152	394985	335364	447152	272018	231029	514225	771338
300	24"	1051432	870151	768633	652613	870151	529342	449578	1000673	1501010

		MAST [Nm]								
		Stem Material								
Code		A	B	C	D	E	F	H	M	N
Class	NPS	ASTM A564 Gr. 630 (17-4PH)	ASTM A276 Gr. 431	ASTM A182 Gr. F55	ASTM A182 Gr. F51	ASTM A453 Gr. 660	ASTM A479 Gr. XM-19 (Nitronic 50)	ASTM UNS N06022 (Hastelloy C22)	ASTM B865 Monel K500	ASTM B 637 UNS N07718 Inconel 718
		1.4542	1.4057	1.4501	1.4462	1.4980	1.3964	2.4602	2.4375	
300	3"	1839	1522	1344	1141	1521	925	786	1749	2624
300	4"	3187	2637	2329	1977	2636	1604	1362	3031	4547
300	6"	7072	5853	5170	4389	5853	3560	3024	6730	10096
300	8"	7072	5853	5170	4389	5853	3560	3024	6730	10096
300	10"	13503	11175	9871	8381	11175	6798	5774	12851	19276
300	12"	22385	18526	16364	13894	18526	11270	9572	21305	31957
300	14"	28023	23191	20486	17393	23191	14108	11982	26670	40005
300	16"	35305	29218	25809	21913	29218	17774	15096	33600	50400
300	18"	61047	50522	44628	37891	50522	30734	26103	58100	87150
300	20"	61047	50522	44628	37891	50522	30734	26103	58100	87150
300	24"	118796	98314	86844	73736	98314	59808	50796	113061	169592

# MAST Class 600

## Maximum Allowable Stem Torque Class 600

		MAST [in-Lb]								
		Stem Material								
Code		A	B	C	D	E	F	H	M	N
Class	NPS	ASTM A564 Gr. 630 (17-4PH)	ASTM A276 Gr. 431	ASTM A182 Gr. F55	ASTM A182 Gr. F51	ASTM A453 Gr. 660	ASTM A479 Gr. XM-19 (Nitronic 50)	ASTM UNS N06022 (Hastelloy C22)	ASTM B865 Monel K500	ASTM B 637 UNS N07718 Inconel 718
		1.4542	1.4057	1.4501	1.4462	1.4980	1.3964	2.4602	2.4375	
600	3"	43545	36038	31833	27028	36038	21923	18619	41443	62165
600	4"	62591	51800	45756	38850	51800	31511	26763	59569	89354
600	6"	89489	51800	45756	38850	51800	31511	40116	59569	127754
600	8"	198126	163967	144837	122975	163967	99746	84716	188561	282842
600	10"	248020	205258	181311	153944	205258	124865	106050	236047	354070
600	12"	363190	225428	265504	225428	300571	182847	155295	345657	518485
600	14"	540309	447152	394985	335364	447152	272018	231029	514225	771338
600	16"	741180	613390	541828	460043	613390	373146	316918	705399	1058098
600	18"	986073	816060	720853	612045	816060	496437	421631	938469	1407704
600	20"	1319974	1092392	964946	819294	1092392	664538	564403	1256251	1884376
600	24"	2145000	1775172	1568069	1331379	1775172	1079897	917172	2041448	3062173

		MAST [Nm]								
		Stem Material								
Code		A	B	C	D	E	F	H	M	N
Class	NPS	ASTM A564 Gr. 630 (17-4PH)	ASTM A276 Gr. 431	ASTM A182 Gr. F55	ASTM A182 Gr. F51	ASTM A453 Gr. 660	ASTM A479 Gr. XM-19 (Nitronic 50)	ASTM UNS N06022 (Hastelloy C22)	ASTM B865 Monel K500	ASTM B 637 UNS N07718 Inconel 718
		1.4542	1.4057	1.4501	1.4462	1.4980	1.3964	2.4602	2.4375	
600	3"	4920	4072	3597	3054	4072	2477	2104	4682	7024
600	4"	7072	5853	5170	4389	5853	3560	3024	6730	10096
600	6"	10111	5853	5170	4389	5853	3560	4533	6730	14434
600	8"	22385	18526	16364	13894	18526	11270	9572	21305	31957
600	10"	28023	23191	20486	17393	23191	14108	11982	26670	40005
600	12"	41035	25470	29998	25470	33960	20659	17546	39054	58581
600	14"	61047	50522	44628	37891	50522	30734	26103	58100	87150
600	16"	83743	69304	61219	51978	69304	42160	35807	79700	119550
600	18"	111412	92203	81446	69152	92203	56090	47638	106033	159050
600	20"	149138	123424	109025	92568	123424	75083	63769	141938	212907
600	24"	242354	200569	177169	150426	200569	122013	103627	230654	345981

# Kv / Cv Values & Torques

## Kv / Cv Values Class 150

Class	NPS	KV 90	CV 90
150	4"	894	1040
150	6"	2276	2647
150	8"	4893	5689
150	10"	7565	8796
150	12"	11272	13107
150	14"	14766	17170
150	16"	19915	23157
150	18"	24894	28946
150	20"	30186	35100
150	24"	43218	50254

## Kv / Cv Values Class 300

Class	NPS	KV 90	CV 90
300	3"	447	520
300	4"	865	1006
300	6"	2176	2530
300	8"	4874	5667
300	10"	7495	8715
300	12"	11165	12982
300	14"	14310	16639
300	16"	19647	22845
300	18"	22882	26607
300	20"	28677	33345
300	24"	42653	49597

## Kv / Cv Values Class 600

Class	NPS	KV 90	CV 90
600	3"	422	491
600	4"	816	949
600	6"	2219	2481
600	8"	4300	5000
600	10"	7093	8248
600	12"	9963	11585
600	14"	13198	15347
600	16"	18656	21693
600	18"	21586	25100
600	20"	26778	31137
600	24"	42536	49461

#150 & #300 CV values are calculated using Pipe Schedule 40  
 #600 CV values are calculated using Pipe Schedule 80

## Torques Class 150

Class	NPS	"Pre-ferred direction [Nm]"	"Pre-ferred direction [lbf-in]"	"Non Preferred direction [Nm]"	"Non Preferred direction [lbf-in]"
150	4"	377	3336	463	4098
150	6"	787	6965	970	8585
150	8"	1046	9257	1419	12558
150	10"	1794	15877	2365	20930
150	12"	2702	23913	3512	31081
150	14"	3967	35108	5489	48578
150	16"	4870	43100	6716	59437
150	18"	8369	74066	10861	96120
150	20"	10046	88907	13050	115493
150	24"	14822	131175	19202	169938

## Torques Class 300

Class	NPS	"Preferred direction [Nm]"	"Pre-ferred direction [lbf-in]"	"Non Preferred direction [Nm]"	"Non Preferred direction [lbf-in]"
300	3"	414	3664	585	5177
300	4"	638	5646	853	7549
300	6"	1297	11478	1771	15673
300	8"	1896	16780	2836	25099
300	10"	3110	27524	4537	40152
300	12"	5143	45516	7169	63446
300	14"	7466	66074	11270	99740
300	16"	9819	86898	14740	130449
300	18"	14836	131299	21044	186239
300	20"	19181	169752	26690	236207
300	24"	29452	260650	40401	357549

## Torques Class 600

Class	NPS	"Pre-ferred direction [Nm]"	"Pre-ferred direction [lbf-in]"	"Non Preferred direction [Nm]"	"Non Preferred direction [lbf-in]"
600	3"	722	6390	1045	9248
600	4"	1227	10859	1725	15266
600	6"	2397	21213	3606	31913
600	8"	4520	40002	6570	58145
600	10"	7795	68986	10787	95465
600	12"	12626	111740	19235	170230
600	14"	15480	136998	22710	200984
600	16"	23171	205063	33372	295342
600	18"	28980	256473	41735	369355
600	20"	39011	345247	59398	525672
600	24"	64838	573816	92085	814952

\*All the torques mentioned are maximum allowable torques

# Flange Bolting

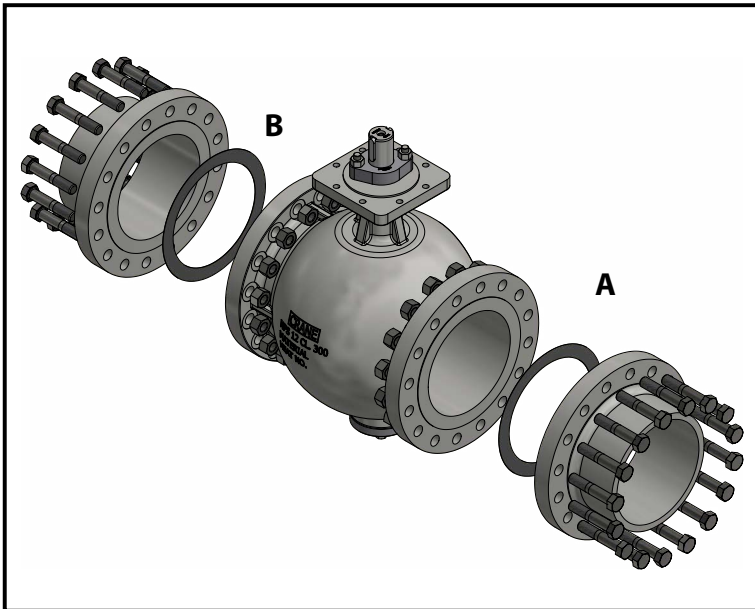

General remark:  
 Quantities of required screws and nuts for the whole valve  
 Counterflange according to AMSE B16.5  
 Flange gasket thickness 2mm  
 Screws according ASME B18.2.1

## Class 150

Flange Face Raised RF acc. ASME B16.5							
Class	NPS	Thread	A Side	Qty	B Side	Qty	Qty nuts
150	4"	5/8-11 UNC	3 1/4"	8	4 1/4"	8	16
150	6"	3/4-10 UNC	3 1/2"	8	4 1/2"	8	16
150	8"	3/4-10 UNC	3 1/2"	8	4 3/4"	8	16
150	10"	7/8-9 UNC	3 3/4"	12	5 1/4"	12	24
150	12"	7/8-9 UNC	4"	12	5 1/2"	12	24
150	14"	1-8 UNC	4 1/4"	12	6"	12	24
150	16"	1-8 UNC	4 1/4"	16	6 1/4"	16	32
150	18"	1 1/8-8 UN	4 3/4"	16	6 1/2"	16	32
150	20"	1 1/8-8 UN	5"	20	7"	20	40
150	24"	1 1/4-8 UN	5 1/2"	20	7 1/2"	20	40

# Flange Bolting

## Class 300

Flange Face Raised RF acc. ASME B16.5				
Class	NPS	Thread	L	Qty nuts
300	3"	3/4-10 UNC	3 1/4"	16
300	4"	3/4-10 UNC	4 1/4"	16
300	6"	3/4-10 UNC	4 1/4"	24
300	8"	7/8-9 UNC	4 3/4"	24
300	10"	1-8 UNC	5 1/4"	32
300	12"	1 1/8-8 UN	5 1/2"	32
300	14"	1 1/8-8 UN	6"	40
300	16"	1 1/4-8 UN	6 1/4"	40
300	18"	1 1/4-8 UN	6 1/2"	48
300	20"	1 1/4-8 UN	7"	48
300	24"	1 1/2-8 UN	7 1/2"	48

## Class 600

Flange Face Raised RF acc. ASME B16.5				
Class	NPS	Thread	L	Qty nuts
600	3"	3/4-10 UNC		16
600	4"	7/8 - 9 UNC		16
600	6"	1-8 UNC	3 3/4"	24
600	8"	1 1/8-8 UN	4 1/4"	24
600	10"	1 1/4-8 UN	4 1/2"	32
600	12"	1 1/4-8 UN	4 3/4"	40
600	14"	1 3/8-8 UN	5"	40
600	16"	1 1/2-8 UN	5 1/4"	40
600	18"	1 5/8-8 UN	5 3/2"	40
600	20"	1 5/8-8 UN	6"	48
600	24"	1 7/8-8 UN	6 3/4"	48

# Mounting Kits

## Class 150

NPS	ISO 5211		Mounting Kit
Class 150	Valve	Actuator	Item Number
4"	F16	F12	MTXLR1F12V036A
		F14	MTXLR1F14V036A
		F16	MTXLR1F16V036A
		F25	MTXLR1F25V036A
6"	F16	F12	MFXTP1F12V027A
		F14	MFXTP1F14V036A
		F16	MFXTP1F16V046A
		F25	MFXTP1F25V055A
8"	F16	F12	MFXTP1F12V027A
		F14	MFXTP1F14V036A
		F16	MFXTP1F16V046A
		F25	MFXTP1F25V055A
10"	F16	F14	MFXUP1F14V036A
		F16	MFXUP1F16V046A
		F25	MFXUP1F25V055A
12"	F25	F14	MFXVP1F14V036A
		F16	MFXVP1F16V046A
		F25	MFXVP1F25V055A
		F30	MFXVP1F30V075A
14"	F25	F16	MFXXP1F16V046A
		F25	MFXXP1F25V055A
		F30	MFXXP1F30V075A
16"	F25	F14	MFXXP1F14V036A
		F16	MFXXP1F16V046A
		F25	MFXXP1F25V055A
		F30	MFXXP1F30V075A
18"	F30	F16	MFXYP1F16V046A
		F25	MFXYP1F25V055A
		F30	MFXYP1F30V075A
20"	F30	F25	MFXVR1F25V055A
		F30	MFXVR1F30V075A
		F35	MFXVR1F35R120A
24"	F35	F16	MFXZN3F16V046A
		F25	MFXZN3F25V055A
		F30	MFXZN3F30V075A
		F35	MFXZN3F35R120A

## Class 300

NPS	ISO 5211		Mounting Kit
Class 300	Valve	Actuator	Item Number
3"	F14	F12	MTXLP1F12V036A
		F14	MTXLP1F14V036A
		F16	MTXLP1F16V036A
4"	F16	F12	MTXLR1F12V036A
		F14	MTXLR1F14V036A
		F16	MTXLR1F16V036A
		F25	MTXLR1F25V036A
6"	F16	F12	MFXTP1F12V027A
		F14	MFXTP1F14V036A
		F16	MFXTP1F16V046A
		F25	MFXTP1F25V055A
8"	F16	F12	MFXTP1F12V027A
		F14	MFXTP1F14V036A
		F16	MFXTP1F16V046A
		F25	MFXTP1F25V055A
10"	F16	F14	MFXUP1F14V036A
		F16	MFXUP1F16V046A
		F25	MFXUP1F25V055A
12"	F25	F14	MFXVP1F14V036A
		F16	MFXVP1F16V046A
		F25	MFXVP1F25V055A
		F30	MFXVP1F30V075A
14"	F25	F16	MFXXP1F16V046A
		F25	MFXXP1F25V055A
		F30	MFXXP1F30V075A
16"	F25	F14	MFXXP1F14V036A
		F16	MFXXP1F16V046A
		F25	MFXXP1F25V055A
		F30	MFXXP1F30V075A
18"	F30	F16	MFXYP1F16V046A
		F25	MFXYP1F25V055A
		F30	MFXYP1F30V075A
		F35	MFXYP1F35R120A
20"	F35	F16	MFXZN3F16V046A
		F25	MFXZN3F25V055A
		F30	MFXZN3F30V075A
		F35	MFXZN3F35R120A
24"	F40	F16	MFXZN3F16V046A
		F25	MFXZN3F25V055A
		F35	MFX1P1F35R120A
		F40	MFX1P1F40R160A

**Class 600**

NPS	ISO 5211		Mounting Kit
Class 600	Valve	Actuator	Item Number
3"	F16	F12	MTXLR1F12V036A
		F14	MTXLR1F14V036A
		F16	MTXLR1F16V036A
		F25	MTXLR1F25V036A
4"	F16	F12	MTXLR1F12V036A
		F14	MTXLR1F14V036A
		F16	MTXLR1F16V036A
		F25	MTXLR1F25V036A
6"	F16	F12	MTXRP1F12V027A
		F14	MTXPR1F14V036A
		F16	MTXPR1F16V046A
		F25	MTXPR1F25V055A
8"	F25	F16	MFXTR1F16V046A
		F25	MFXTR1F25V055A
		F30	MFXTR1F30V075A
10"	F30	F25	MFXUR1F25V055A
		F30	MFXUR1F30V075A
		F35	MFXUR1F35R120A
12"	F30	F25	MFXVR1F25V055A
		F30	MFXVR1F30V075A
		F35	MFXVR1F35R120A
14"	F30	F25	MFXVR1F25V055A
		F30	MFXVR1F30V075A
		F35	MFXVR1F35R120A
16"	F35	F25	MFXZP3F25V055A
		F30	MFXXR1F30V075A
		F35	MFXXR1F35R120A
		F40	MFXXR1F40R160A
18"	F40	F30	MFXYR1F30V075A
		F35	MFXYR1F35R120A
		F40	MFXYR1F40R160A
		F48	MFXYR1F48R180A
20"	F48	F35	MFXZR1F35R120A
		F40	MFXZR1F40R160A
		F48	MFXZR1F48R180A
24"	F48	F35	MFX2R1F35R120A
		F40	MFX2R1F40R160A
		F48	MFX2R1F48R180A

# Geometry Tables for Gear Operated Valves

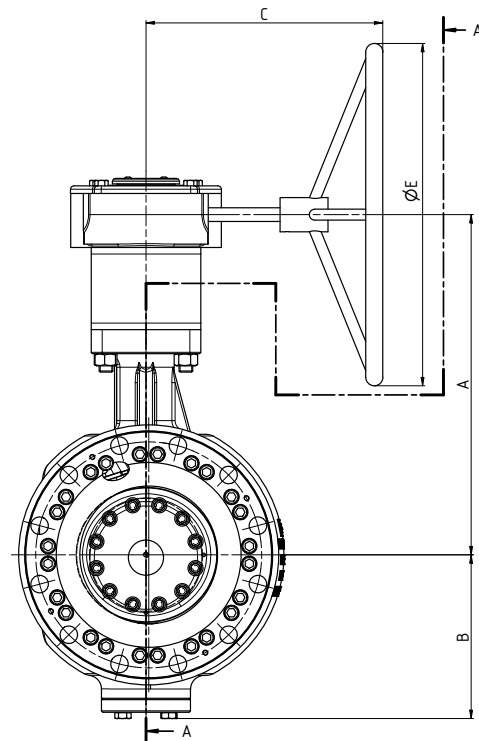
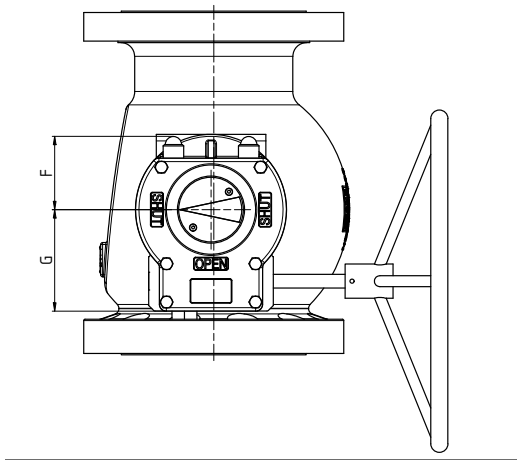
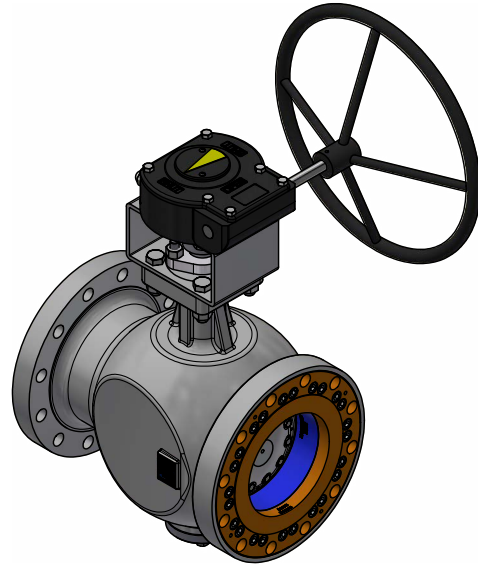
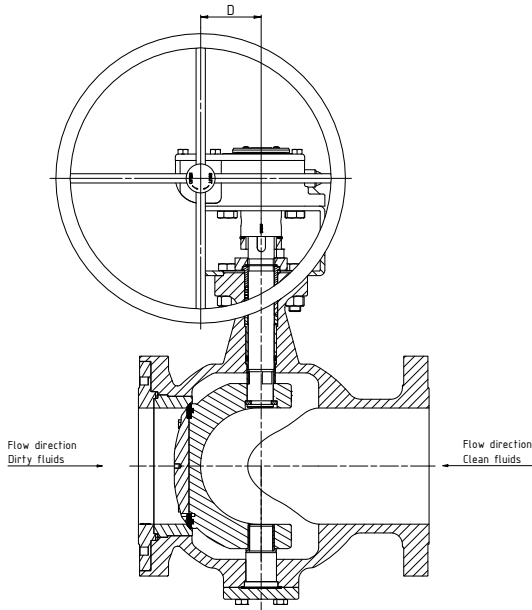

# Geometry Tables for Gear Operated Valves

## Class 150

Class	NPS	Dimensions (inch)							Weights (lb)
		150	B	C	D	øE	F	G	
150	4"	14.94	6.34	9.92	2.99	7.87	2.72	4.13	156.48
150	6"	17.13	7.95	10.43	3.39	15.74	3.94	4.96	245.81
150	8"	18.11	9.41	10.83	3.39	17.71	3.94	4.96	372.65
150	10"	22.50	11.63	12.44	4.11	19.68	4.33	5.83	580.67
150	12"	25.28	13.35	13.62	4.11	19.68	4.33	5.83	917.75
150	14"	25.42	15.65	12.52	5.12	19.68	5.59	5.91	1196.24
150	16"	29.53	17.05	14.84	5.12	19.68	5.61	7.09	1553.16
150	18"	34.84	20.43	18.50	7.17	23.62	6.69	9.33	2329.63
150	20"	40.16	21.77	17.74	7.17	23.62	8.17	9.35	2966.58
150	24"	46.54	24.63	20.89	10.08	23.62	9.25	13.78	5040.55

## Class 300

Class	NPS	Dimensions (inch)							Weights (lb)
		80	B	C	D	øE	F	G	
300	3"	13.62	6.02	9.72	2.80	7.87	2.72	4.13	123.42
300	4"	14.96	6.42	9.72	2.80	7.87	2.72	4.13	176.32
300	6"	17.13	7.95	10.43	3.39	15.75	3.94	4.96	406.68
300	8"	18.11	9.41	10.83	3.39	19.69	3.94	4.96	648.59
300	10"	22.50	11.63	12.44	4.11	19.69	4.33	5.83	1015.25
300	12"	25.28	13.35	13.62	4.11	19.69	4.33	5.83	1530.28
300	14"	25.42	15.65	12.52	5.12	19.69	5.59	5.91	1771.49
300	16"	29.53	17.05	14.84	5.12	19.69	5.61	7.09	2818.76
300	18"	37.80	20.43	19.31	8.23	23.62	8.17	11.18	2997.44
300	20"	42.32	21.77	20.12	10.08	27.56	9.25	13.78	3987.04
300	24"	48.84	26.85	27.01	3.98	23.62	11.81	14.17	6995.50

## Class 600

Class	NPS	Dimensions (inch)							Weights (lb)
		A	B	C	D	øE	F	G	
600	3"	13.72	6.10	10.91	2.80	9.84	2.72	4.13	147.67
600	4"	17.01	7.09	12.83	4.11	15.75	5.63	5.83	273.30
600	6"	24.41	8.58	14.84	5.12	17.72	5.61	7.09	493.17
600	8"	26.54	11.40	15.55	5.51	19.69	6.89	7.76	876.11
600	10"	28.74	13.39	17.32	7.17	19.69	6.69	9.35	1332.47
600	12"	33.27	14.63	17.76	8.23	19.69	8.17	11.18	1938.59
600	14"	34.65	17.23	17.95	8.23	19.69	8.17	11.18	2218.35
600	16"	36.02	18.70	20.12	10.08	19.69	9.25	13.78	3174.18
600	18"	43.60	21.06	27.01	3.96	23.62	11.81	14.17	5333.68
600	20"	46.97	23.23	30.12	15.00	19.69	15.67	19.25	7418.66
600	24"	48.23	26.52	31.14	15.00	27.56	15.67	19.25	9702.01

# Geometry Tables for Gear Operated Valves

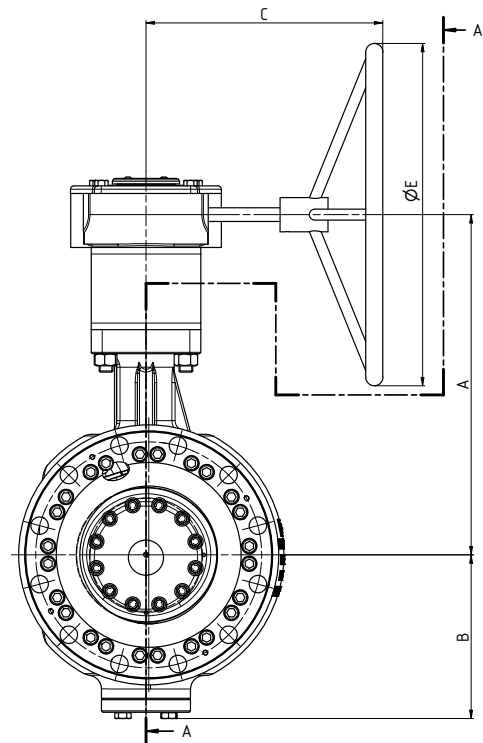
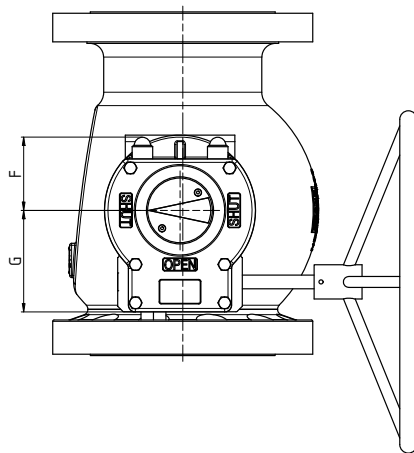
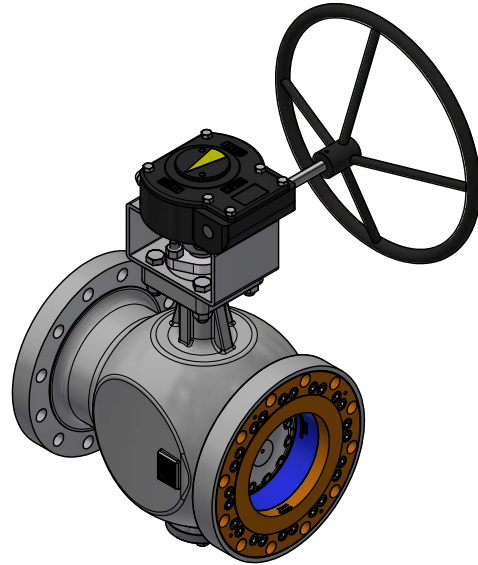
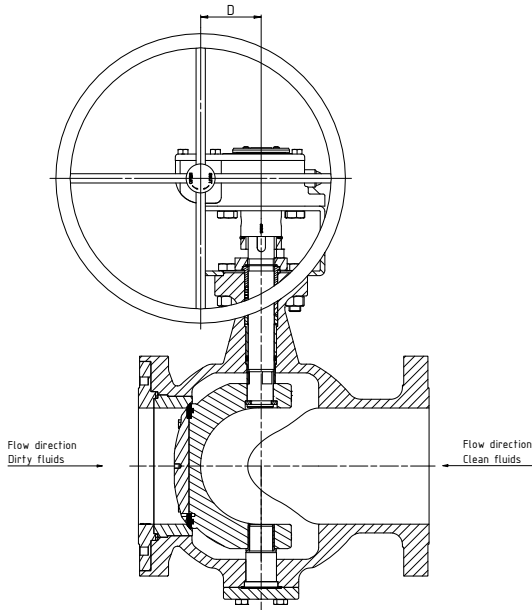

# Geometry Tables for Gear Operated Valves

## Class 150

Class	NPS	Dimensions (mm)							Weights (kg)
		A	B	C	D	øE	F	G	
150	4"	380	161	252	76	200	69	105	71
150	6"	435	202	265	86	400	100	126	112
150	8"	460	239	275	86	450	100	126	169
150	10"	572	295.5	316	105	500	110	148	263
150	12"	642	339	346	105	500	110	148	416
150	14"	646	397.4	318	130	500	142	150	543
150	16"	750	433	377	130	500	142.5	180	705
150	18"	885	519	470	182	600	170	237	1057
150	20"	1020	553	451	182	600	207.5	237.5	1346
150	24"	1182	625.5	531	256	600	235	350	2287

## Class 300

Class	NPS	Dimensions (mm)							Weights (kg)
		A	B	C	D	øE	F	G	
300	3"	346	153	247	71	200	69	105	56
300	4"	380	163	247	71	200	69	105	80
300	6"	435	202	265	86	400	100	126	185
300	8"	460	239	275	86	500	100	126	294
300	10"	572	296	316	105	500	110	148	461
300	12"	642	339	346	105	500	110	148	694
300	14"	646	397	318	130	500	142	150	804
300	16"	750	433	377	130	500	143	180	1279
300	18"	960	519	491	209	600	208	284	1360
300	20"	1075	553	511	256	700	235	350	1809
300	24"	1241	682	686	101	600	300	360	3174

## Class 600

Class	NPS	Dimensions (mm)							Weights (kg)
		A	B	C	D	øE	F	G	
600	3"	349	155	277	71	250	69	105	67
600	4"	432	180	326	104.5	400	143	148	124
600	6"	620	218	377	130	450	142.5	180	224
600	8"	674	289.5	395	140	500	175	197	398
600	10"	730	340	440	182	500	170	237.5	605
600	12"	845	371.6	451	209	500	207.5	284	880
600	14"	880	437.7	456	209	500	207.5	284	1007
600	16"	915	475	511	256	500	235	350	1440
600	18"	1107.5	535	686	101	600	300	360	2420
600	20"	1193	590	765	381	500	398	489	3366
600	24"	1225	673.6	791	381	700	398	489	4402

# Product Coding

PRODUCT LINE		VALVE TYPE			MATERIAL GROUP		
Valve	Size	Pressure	Body Style	Body Material	Disc Material	Shaft Material	

## PRODUCT LINE

Valve
FKT

## VALVE TYPE

Size	
3"	03
4"	04
6"	06
8"	08
10"	10
12"	12
14"	14
16"	16
18"	18
20"	20
24"	24

Pressure	
Class 150	N
Class 300	P
Class 600	R

Body Style	
L-Ring Design Double flanged ASME B16.10 (Ball Valve) long pattern	LR
Other	XX

## MATERIAL

Body Material	
ASTM A216 Gr. WCB Carbon steel	A
ASTM A351 Gr. CF8M Stainless steel	B
ASTM A216 Gr. WCC Low alloy steel	C
A217-C12	D
ASTM A352 Gr. LCB Low temperature CS	E
ASTM A352 Gr. LCC Low temperature CS	F
ASTM A216 Gr. WCC6 Low alloy steel	G
ASTM A494 Gr. N7M Hastelloy B-2	H
904L - CN2MCuN	J
A217 Gr. C5	K
ASTM A351 Gr. CF3M	L
A494 Gr. Monel M35-1	M
Inconel 600	N
ASTM A494 - CX2MW (Hastelloy C-22)	P
ASTM A995 Gr. 6A Superduplex	R
Titanium gr. 2	T
ASTM A216 Gr. WC9 Low alloy steel	W
Other	X
Zirconium 705C	Z

Shaft Material	
ASTM A564 Gr. 630 17-4 PH, double heat treated	A
ASTM A276 Gr. 431 Stainless steel	B
A182-F51	C
ASTM A479 F51/ 1.4462	D
ASTM A453 Gr. 660 for high temperatures	E
ASTM A276 Gr. XM-19 Nitronic 50*	F
Hastelloy C-22	G
Hastelloy C276*	H
ASTM A638 Gr 660/ 1.4980 (Incoloy A-286)	I
ASTM B335 Hastalloy B2*	K
ASTM A494 Gr. M30H Monel 500	M
Inconel 718	N
Other	X
Zirconium 705C*	Z
Titanium gr. 12	T

Disc Material	
ASTM A216 Gr. WCB Carbon steel	A
ASTM A351 Gr. CF8M Stainless steel	B
ASTM A216 Gr. WCC Low alloy steel	C
A217-C12	D
ASTM A352 Gr. LCB Low temperature CS	E
ASTM A352 Gr. LCC Low temperature CS	F
ASTM A216 Gr. WCC6 Low alloy steel	G
ASTM A494 Gr. N7M Hastelloy B-2	H
904L - CN2MCuN	J
A217 Gr. C5	K
ASTM A351 Gr. CF3M	L
A494 Gr. Monel M35-1	M
Inconel 600	N
ASTM A494 - CX2MW (Hastelloy C-22)	P
ASTM A995 Gr. 6A Superduplex	R
Titanium gr. 2	T
ASTM A216 Gr. WC9 Low alloy steel	W
Other	X
Zirconium 705C	Z

Seal Ring / Triex Seat Combination	
Titanium Gr. 5/Graphite	T
Titanium gr. 5/ PTFE	P
Monel K500 /Graphite	M
Monel K500 / PTFE	N
Inconel 625 /Graphite	I
Hastelloy B3 + PTFE	H
Other	X

\* Contact Engineering for shaft material offering

\*\* 3" Class 150 is not possible to offer

# Product Coding

	FLANGE FACE	GLAND / PACKING / TOP WORK OPTIONS			ACTUATION	OPTIONS
Seal Ring / TriEX Seat Combination	Flange Type	Gland Packing	Packing Box	Gland Flange Design	Operator Type	Options

FLANGE FACE	
Flange Type	
Flat face FF acc. ANSI B16.5	6
Raised face RF acc. ANSI B16.5	A
Raised face RF acc. ANSI B16.5 & FTF acc. to customer requirement	F
Flange drilling acc. to customer requirement	D
RTJ Flange	R
Other	X

GLAND / PACKING / TOP WORK OPTIONS	
Gland Packing	
Standard graphite packing (ISO 15848 AH CO2 / TA-Luft and API 641)	1
High temperature graphite packing (TA-Luft)	5
High temperature graphite packing (non-FE / non-TA-Luft / EN12266 A / API598)	6
Packing Box	
Single packing	A
Single packing with monitoring port with STD design	C
Single packing with pressure tight bearing	G
Single packing with monitoring port and pressure tight bearing protector	R
Other	X
Gland Flange ype	
Standard design	A
Live loaded	L
Other	X

ACTUATION	
Operator Type	
Electric	E
Bare shaft	F
Manual, gear operated	G
Hydraulic	H
Mounting kit	M
Pneumatic, rack and pinion	R
Pneumatic, scotch yoke	Y
Other	X

OPTIONS	
Options	
Any special request from customer	XX
Nace mr0175	N5
Nace mr0103	N3
High temperature up to 550°C	H5
All internal components made From 316 stainless steel	SS
According dt91 standard	D9
Heating jacket	HJ
With CE marking	CE
Tested according astmg93	G93
Tested according en15848-2	E2
Stem extension	ST
Special grease/oil ( as per customer request)	SP
Oil & grease free assembly ( o2 service)	OG
With all actuator accessories	AC
High pressure closer test ( pressure to be defined by customer)	HP
Free from oil and grease, Cleaned for oxygen acc. To qs-aa 002	OX
Silicone cleaning acc. To tb-va 012	SC
Castings with european origin	EU







---

**CRANE CHEMPHARMA & ENERGY**

Xomox International GmbH & Co. OHG  
Von-Behring-Straße 15  
88131 Lindau/Bodensee, Germany  
Tel: +49 8382 702 0

4526 Research Forest Drive,  
Suite 400  
The Woodlands  
Texas 77381, U.S.A.  
Tel: +1 936 271 6500

ARMATURE d.o.o.  
Koroška cesta 55  
2366 Muta, Slovenia  
Tel: +386 2 87 70 500  
[quote-armature@cranecpe.com](mailto:quote-armature@cranecpe.com)

---

Crane Company, and its subsidiaries cannot accept responsibility for possible errors in catalogues, brochures, other printed materials, and website information. Crane Company reserves the right to alter its products without notice, including products already on order provided that such alteration can be made without changes being necessary in specifications already agreed. All trademarks in this material are the property of the Crane Company or its subsidiaries. The Crane and Crane brands logotype (ALOYCO®, BAUM®, CENTER LINE®, CRANE®, CRANE CRYOGENICS™, CRYOWORKS®, DEPA® & ELRO®, DOPAK®, DUO-CHEK®, FLOWSEAL®, GYROLOK®, GO REGULATOR®, HOKE®, JENKINS®, KROMBACH®, NOZ-CHEK®, PACIFIC®, RESISTOFLEX®, XOMOX®, SAUNDERS®, STOCKHAM®, TECHNIFAB®, TEXAS SAMPLING®, WESTLOCK®, WTA®, and XOMOX®) are registered trademarks of Crane Company. All rights reserved.