



FULL PORT TRIPLE OFFSET VALVE WITH CAVITY FREE DESIGN THAT PROVIDES ZERO LEAKAGE SHUTOFF

CRANE® FK-TrieX™
Full Port Triple Offset Isolation
Valves For Severe Service

CRANE

v in www.cranecpe.com

Features and Benefits

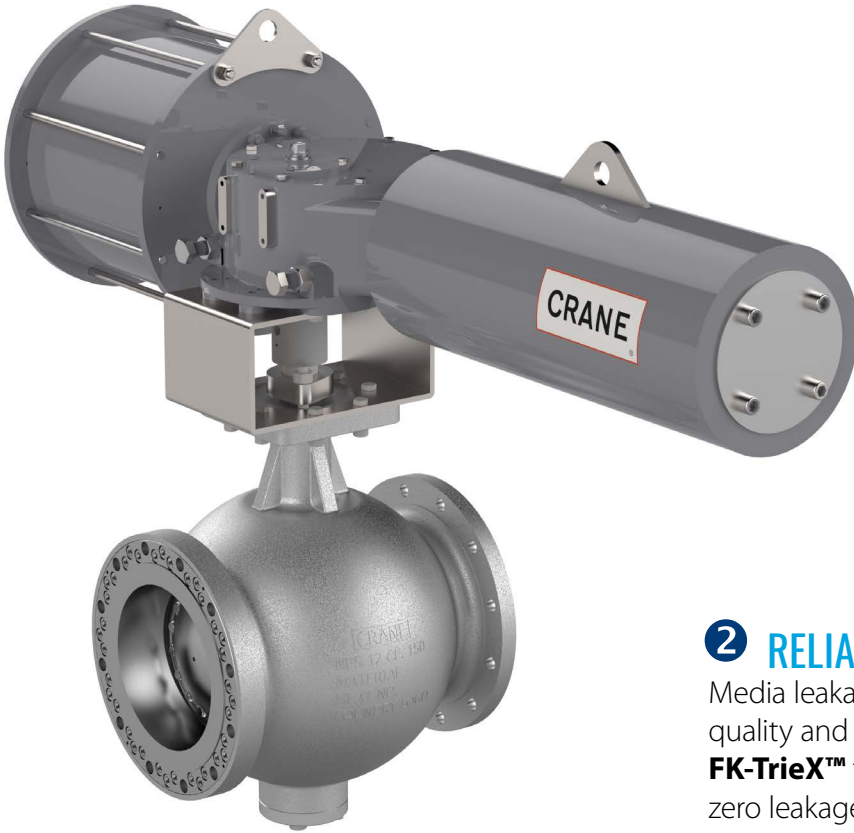

1 SAFETY

With **CRANE® FK-TrieX™** severe service isolation valves, you can run safe and environmentally responsible operations, prevent high consequence incidents including fire, explosion and leakages, and eliminate risk to the health and safety of employees, assets and communities.

2 RELIABLE OPERATIONS

Media leakage through valves can impact the quality and delivery of your products. **CRANE® FK-TrieX™** features repeatable, bidirectional, zero leakage shutoff and can help you achieve higher product output by reducing unplanned shutdowns from valve failures and by reducing planned valve maintenance time. When necessary, the ability to replace the modular seat and seal ensures minimal downtime.

3 LOW OVERALL COST

CRANE® FK-TrieX™ enhances the long term value of your investment. Relative to existing full port isolation technologies, you can realize both upfront and long-term cost savings in the form of simpler actuators, single piece body, reduced cost of planned maintenance due to the modular seat design and minimal product wastage costs. The high Cv of **CRANE® FK-TrieX™** permits reduction in line size when replacing butterfly valves and sleeved plug valves.

Design Advantages

CRANE® FK-TrieX™ is an isolation valve that features high Cv in the form of unobstructed flow, bi-directional zero leakage shutoff and cavity free design at low overall cost. This valve design includes the best features of severe service ball valves and harnesses the economy and reliability of triple offset valves into a powerful, versatile hybrid. **CRANE® FK-TrieX™ is full port triple offset valve**, that provides:

- 1. BIDIRECTIONAL ZERO LEAKAGE SHUTOFF: Per API 598**
when you need critical absolute process & media isolation
- 2. HIGH Cv & LOW PRESSURE DROP ACROSS VALVE:** With patented optimized disc profile that permits full bore design and unobstructed flow
- 3. UNPARALLED RELIABILITY:** With proven Triple Offset sealing mechanism, cavity free design and longer-lasting modular seat and seal
- 4. SUPERIOR SOLIDS HANDLING CAPABILITY:** That can handle solids & polymerizable media
- 5. BEST IN CLASS FUGITIVE EMISSIONS CONTROL:**
Per ISO 15848-1 AH CO2 SSA0 & API 641
- 6. INHERENTLY SAFE DESIGN:** that is fire-safe tested per **API 607, SIL3** certified per IEC 61508, **single piece body** & with **blow out proof stem**
- 7. SIMPLER ACTUATION:** Due to quarter turn design & low closing/opening torques in preferred flow direction
- 8. REPAIRABLE / REPLACEABLE SEAT & SEAL:** Permits resurfacing and modular replacement, reducing downtime, and increasing the life span of the valve
- 9. LOWER OVERALL COST & HIGHER ROI**



ADVANTAGES VS OTHER METAL SEATED ISOLATION VALVE TECHNOLOGIES

REPLACEMENT POSSIBLE	Ball Valve (Rising Stem and Quarter Turn)	Gate Valve	Butterfly Valve	Wedge Plug Valve
Raised Face and Flanged End				
CRANE® FK-TrieX™ BENEFITS	<ul style="list-style-type: none"> • Simpler actuation compared to rising stem • Lower cost of ownership relative to zero leakage full port ball • Ease of serviceability 	<ul style="list-style-type: none"> • Zero leakage shutoff • Superior fugitive emissions control • Simpler quarter turn actuation 	<ul style="list-style-type: none"> • Higher Cv / minimal pressure drop • Ease of serviceability 	<ul style="list-style-type: none"> • Reduced torque • Lower cost of ownership

Product Overview

Materials of Construction

- WCB, WCC, LCB, LCC, WC6, WC9, C12, CF3M, CF8M, Duplex, Super Duplex, Monel, Inconel, Hastelloy, Titanium, Zirconium

Size Range

3" to 24" in single piece cast body design

Pressure Ratings

- ASME Class 150, 300, 600

Temperature Range

- -76°F up to 1022°F; -60°C up to 550°C, depending on material

Body Configurations

- ASME B16.10: Double Flanged Long (ball valve)

Standard Features and Compliance

- Dimensional compliance to API 6D
- Fugitive Emissions Control per ISO 15848-1 AH CO2 & API 641
- Fire Safe Design per API 607
- ASME B16.10: Double Flanged Long (ball valve)

- Cavity-free design
- Single packing with Pressure-Tight Bearing
- Removable seat and seal

Additional Optional Features

- Gear operator with handwheel
- Pneumatic or electric actuation
- Solenoid valve, limit switch, pressure regulator
- Heating Jacket
- Design compliant to NACE MR0175 and NACE MR0103
- High temperature Graphite packing
- Single packing with Pressure Tight Bearing & Monitoring port
- Bearing protector for bottom stem
- Welded bottom cover for hazardous & toxic media
- Capping valve design
- Oil & grease free assembly
- Stem extension
- DT91 impact testing
- G93 certification for Oxygen service

NPS (inch)	Class 150	Class 300	Class 600
3"	●	●	●
4"	●	●	●
6"	●	●	●
8"	●	●	●
10"	●	●	●
12"	●	●	●
14"	●	●	●
16"	●	●	●
18"	●	●	●
20"	●	●	●
24"	●	●	●

● = available
● = Not available

Design Features

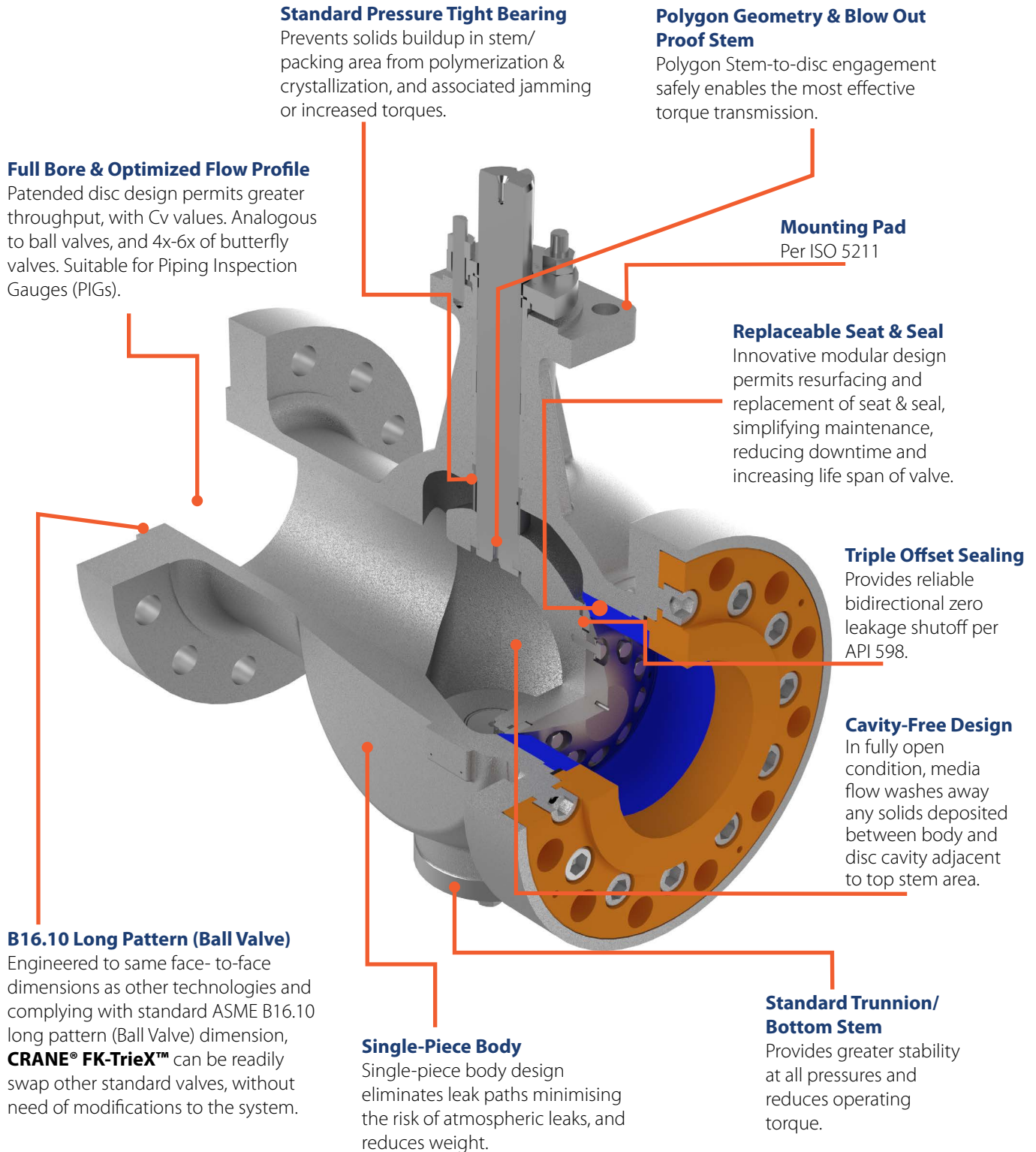

Standard Pressure Tight Bearing
Prevents solids buildup in stem/ packing area from polymerization & crystallization, and associated jamming or increased torques.

Polygon Geometry & Blow Out Proof Stem
Polygon Stem-to-disc engagement safely enables the most effective torque transmission.

Full Bore & Optimized Flow Profile
Patented disc design permits greater throughput, with Cv values. Analogous to ball valves, and 4x-6x of butterfly valves. Suitable for Piping Inspection Gauges (PIGs).

Mounting Pad
Per ISO 5211

Replaceable Seat & Seal
Innovative modular design permits resurfacing and replacement of seat & seal, simplifying maintenance, reducing downtime and increasing life span of valve.

Triple Offset Sealing
Provides reliable bidirectional zero leakage shutoff per API 598.

Cavity-Free Design
In fully open condition, media flow washes away any solids deposited between body and disc cavity adjacent to top stem area.

B16.10 Long Pattern (Ball Valve)
Engineered to same face- to-face dimensions as other technologies and complying with standard ASME B16.10 long pattern (Ball Valve) dimension, **CRANE® FK-TrieX™** can be readily swap other standard valves, without need of modifications to the system.

Single-Piece Body
Single-piece body design eliminates leak paths minimising the risk of atmospheric leaks, and reduces weight.

Standard Trunnion/ Bottom Stem
Provides greater stability at all pressures and reduces operating torque.

Design Features

1) SAFETY:

With **CRANE® FK-TriEX™** severe service isolation valves, you can run safe & environmentally responsible operations, prevent high consequence incidents including fire, explosion & leakages, and eliminate risk to health & safety of employees, assets & communities.

Proven Triple Offset Sealing

CRANE® FK-TriEX™ valves are bidirectional valves with zero leakage per API 598. Utilizing high modulus material and graphite in laminate seal, the full triple offset geometry provides durable and reliable zero leakage operation.

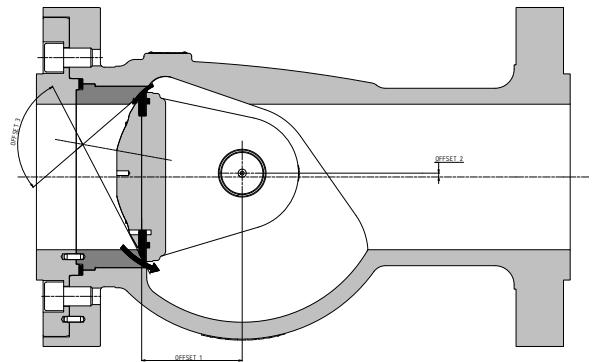

Torque Assisted Seating

The sealing occurs due to self adjustment of the “floating” seal ring (laminate seat) and the applied torque. A slight increase in torque yields a better seal due to a more evenly distributed compression of the seal ring along the entire sealing area. The applied torque also ensures a bi-directional seal.

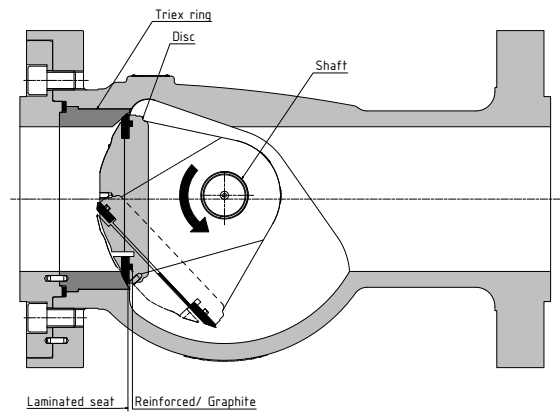

Superior Fugitive Emissions Control

CRANE® FK-TriEX™ meets the highest standards, with certifications to API 641 and ISO 15848 AH C02 SSA0. The stem seal technology is built on the same innovative platform as the **CRANE® FKX9000**, providing critical performance in an uncompromising design.

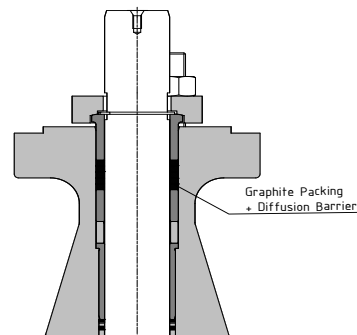

Design Features

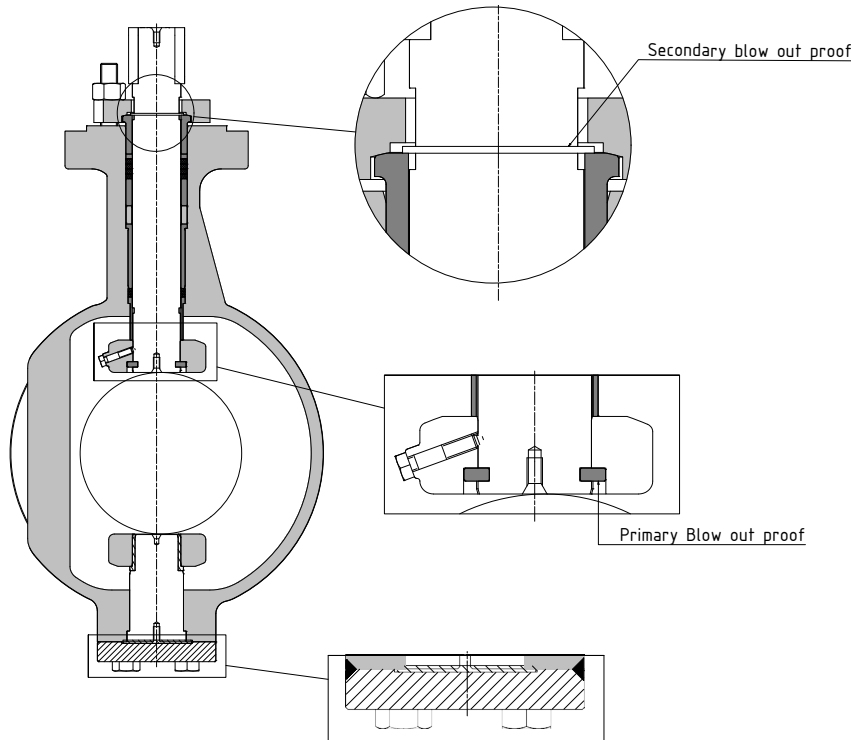

Blow Out Proof Stem

Double safety feature maximises safety for the valve operator. Primary blow-out feature is the stem retainer / split ring at the bottom of top stem. Secondary blow-out feature is the retainer at the top of the top stem.

Single-Piece Body

The single-piece body design eliminates leak path between body flanges that is typical of split body design. It also reduces weight by up to 10% to 20% decreasing structural support costs.

Fire Safe Design

CRANE® FK-TrieX™ meets the rigorous standards of API 607 fire test for quarter-turn valves, confirming its pressure-containing capability during and after the test.

SIL3 Certified

Per IEC 61508, which signifies greater functional safety & Risk Reduction Factor.

Design Features

2) RELIABILITY:

CRANE® FK-TrieX™ is designed to provide reliable performance, so that you can operate your plants reliably and deliver quality products to your customers.

Cavity Free Design

FK-TrieX™ does not have macro cavities where solids can entrap. In fully open condition, media flow washes away any solids deposited between body and disc cavity adjacent to top stem area, making it a self-cleaning design.

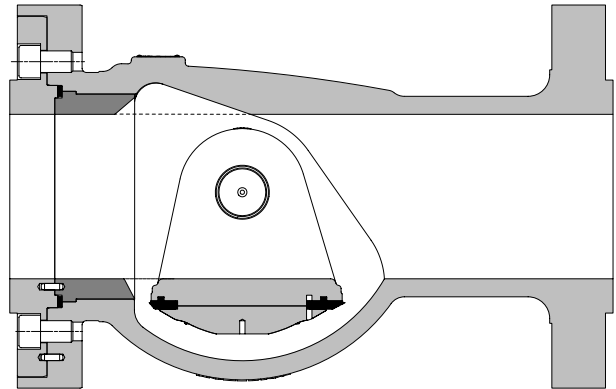

Long Lasting Sealing

Utilizing high modulus material and Graphite in laminate seal, the triple offset geometry provides durable and reliable operation with zero leakage.

The replaceable stellite welded seat with an RC hardness rating of 40 (powder plasma Stellite) and flexible laminate seal provide excellent shutoff and approximately double the life of regular stainless-steel seat.

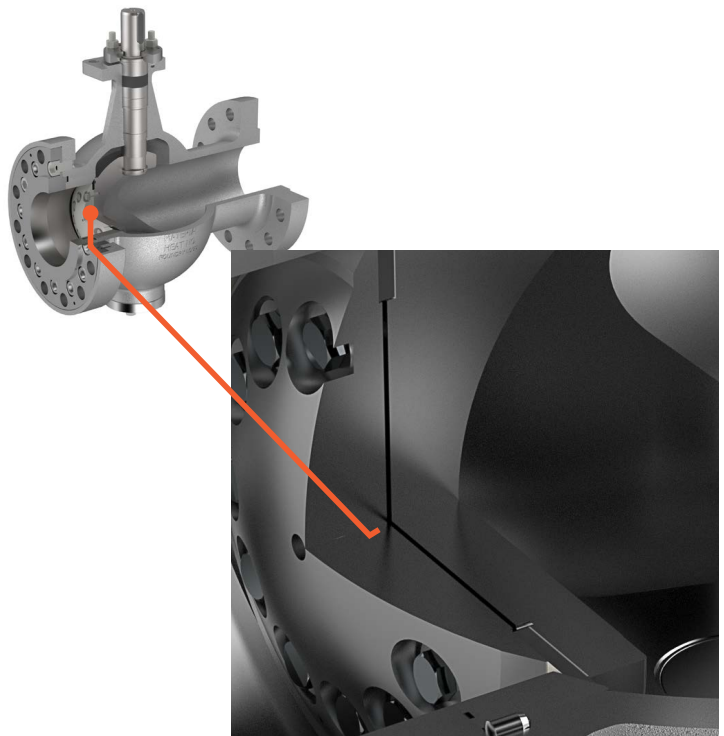

Design Features

Reduced Friction Sealing

Wear that is typically seen in other technologies due to spring force or other impinging force on seat is absent in FK-TrieX™.

The optimal triple offset angle ensures contact between seat and seal at the last few degrees of disc rotation, thereby facilitating an almost frictionless inline sealing

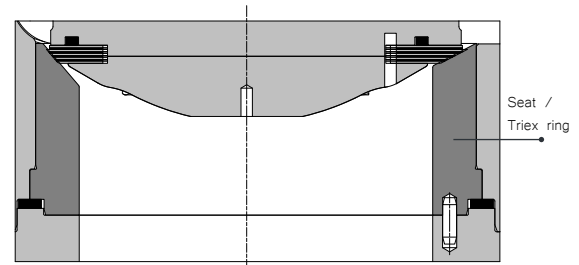

Standard Pressure Tight Bearing

Pressure Tight Bearing is standard in all FK-TrieX™ valves, hence solids build up in the stem/packing area is eliminated.

As a result, FK-TrieX™ is ideal for applications where polymerisation or crystallization in packing area is a common pain point, which results in valve seizure (or valve sticking) and/or high closing or opening torques.

Bearing protector is also available in bottom trunnion/ stem to prevent solids from entrapping in cavities.

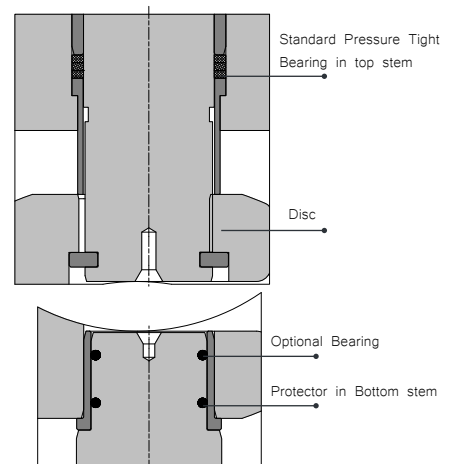

Patented Polygon Design

The polygon profile on top stem and disc enables the most effective torque transmission.

It provides higher safety against stem deformation and reduces stress load into disc.

The polygon also ensures proper alignment of the disc and sealing plane that is critical for zero leakage shutoff.

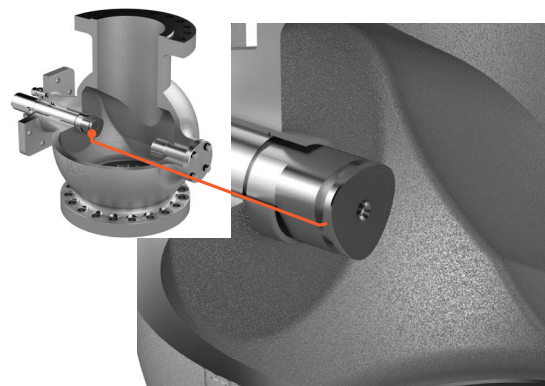

Design Features

Standard Bottom Trunnion/ Stem

The bottom trunnion or stem supports the disc inside the body.

It prevents unreasonable friction between seat and seal by absorbing thrust from flow pressure. This greater stability results in reduced operating torques and reliable performance at all pressures.

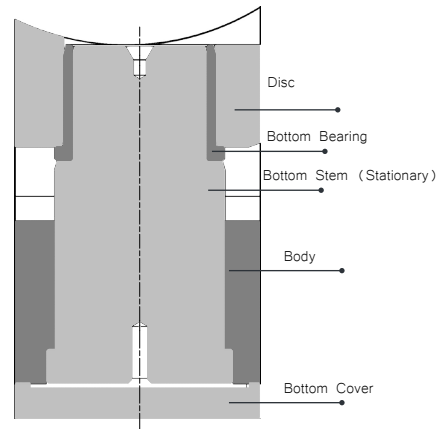

3) LOW OVERALL COST OF OWNERSHIP

CRANE® FK-TrieX™ enhances long term value of your investment. Relative to existing severe service full bore metal seated isolation technologies that provide minimal inline leakage, you can realize both upfront and long term cost savings with FK-TrieX™.

Unobstructed Flow & API 6D Compliant Full Bore Design

The standard full-bore architecture enabled by the unique disc design affords an optimal flow profile with high Cv and low-pressure drop across the valve.

This, in turn, provides the ability to reduce line size in systems with butterfly valves and full port plug valves, thereby reducing upfront cost as well as structural support costs.

The full bore design allows Pipeline Inspection Gauges (PIGs), cleaning scrapers & hydrojet tubes to pass through, allowing the system to be cleaned without needing to remove the valve from pipeline, further saving labor and maintenance costs.

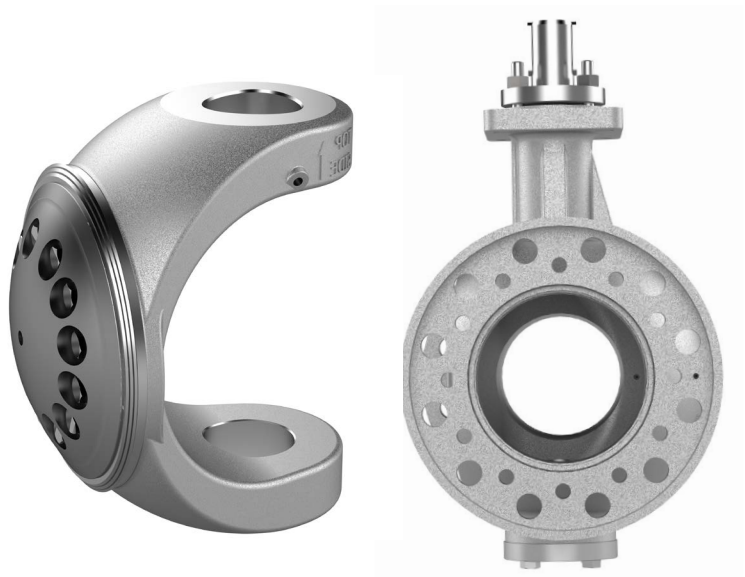

Design Features

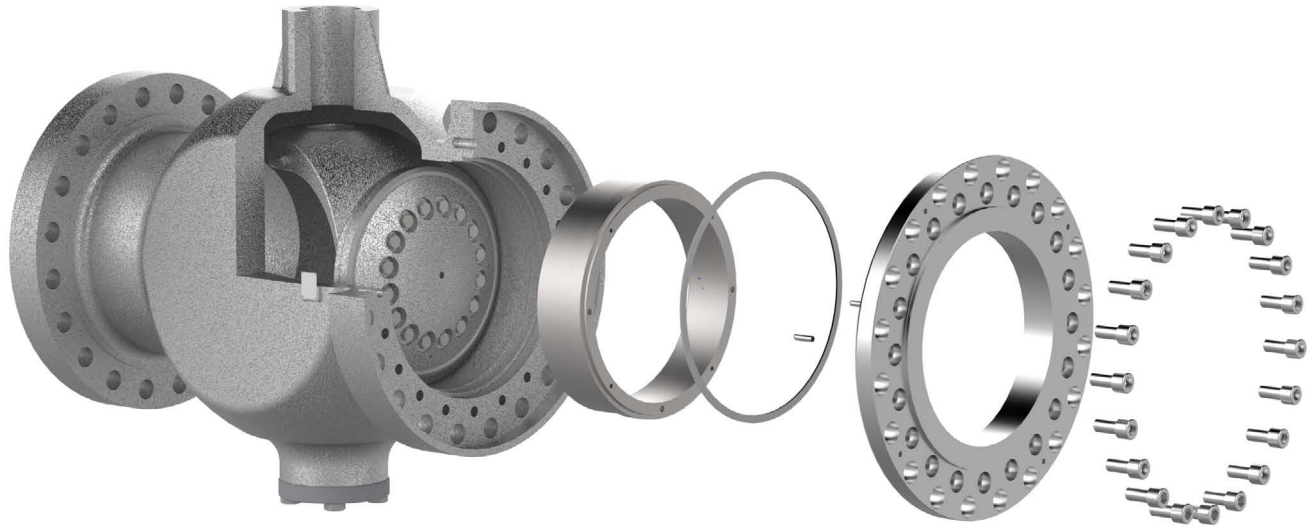

Modular Seat & Seal Design

The modular seat & seal design simplifies maintenance and reduces downtime. Due to the modular sealing mechanism, the seat and laminate seal can be replaced independently, without having to replace the entire valve.

Simpler Actuation

FK-TrieX's quarter turn design eliminates the need for complex actuation, compared to rising stem or multiturn technologies.

Double Flanged Long Design (Ball Valve)

Flange to flange dimensions are in accordance with ASME B16.10 Double flanged long (ball valve), minimizing the need for piping changes when replacing similar alternative technologies



Applications

CRANE® FK-TriEX™ is an ideal solution for severe service applications with the ability to perform under demanding conditions while offering unmatched safety, reliability of operations, and a greatly reduced cost of ownership.

FUNCTION	
ON / OFF	●
Throttling	●
Modulation System	●

MEDIA TYPES	
Clean Liquids & Gases	●
Dirty Liquids & Gasses	●
Corrosive Liquids & Gases	●
Hazardous Liquids	●
Viscous Liquids	●
Abrasive Slurries	●
High Temperatures	●
Vacuum Service	●

Industries

- Oil & Gas
- Chemical & Petrochemical Plants
- Hydrocarbons Storage & Transportation
- Refineries
- Offshore Platforms
- Pulp & Paper
- Metals & Mining
- Desalination Plants
- Water Treatment & Distribution
- Power Generation
- District Heating

APPLICATION REQUIREMENTS	
Bi-directional *Zero Leakage	●
Cavity Free	●
Full Bore (API 6D)	●
Fugitive Emissions Control	●
Extended Service Life	●
Reduced Maintenance	●
Sizes	3"-24" / DN80-DN600
Pressure Range	Class 150-600
High Temperature	1022°F / 550°C
Low Temperature	-76°F / -60°C

*Per API 598

● Ideal ● Consult Factory

Processes

- **Chemical Processing:**
 - Aromatics & Derivatives
 - Chlor Alkali & Chlorinated Hydrocarbons
 - Fluorinated Hydrocarbons
 - Industrial Gases
 - Inorganic Chemicals
 - Inorganic Pigments
 - Nitrogenous Fertilizers
 - Olefins & Derivatives
 - Organic Compounds
 - Phosphatic Fertilizers
 - Specialty Chemicals
 - Synthetic Polymers, Plastics & Resins
- **Refining**
- **Terminals**
- **Pulp & Paper**
- **Gas Processing**
- **Carbon Capture & Sequestration**

Actuation

CRANE® FK-TrieX™ uses quarter turn technology. Using traditional actuation and only rotary movement, **CRANE® FK-TrieX™** can easily achieve SIL 3 ratings on full automation packages. Utilizing quarter turn actuation devices significantly reduces complexity and cost of automated valves.

CRANE® FK-TrieX™ is an excellent solution in Emergency Shut Down (ESD) applications, Safety Interlock Systems (SIS) and in other critical service conditions that require quick shut off capability.

Gears



Gear boxes are for manual actuation of valves. They provide a travel of 90° for simple on/off applications. The self-jamming worm gear prevents involuntary movements. Several accessories can be equipped like a padlock, chainwheel and limit switches.

Scotch & Yoke Actuators



Scotch & Yoke are available as pneumatic or hydraulic actuators. The linear movement of the pressure operated piston is transferred into a rotatory movement of the yoke. They have an increased torque range compared to Rack & Pinion actuators. Scotch & Yoke actuators are available as double-acting actuators or as single-acting spring return actuators for safety reasons. Several accessories can be equipped like solenoid valves, smart positioners, limit switches, etc.

Pneumatic Rack & Pinion Actuators

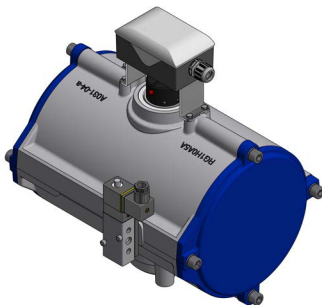

In Rack & Pinion pneumatic actuators, linear gear “the rack” engages teeth on a circular gear “the pinion”. Common design includes two piston racks in opposite directions. By applying pneumatic pressure on piston racks, the pinion and hence the valve disc, can be turned to the desired position.

Electric Actuators

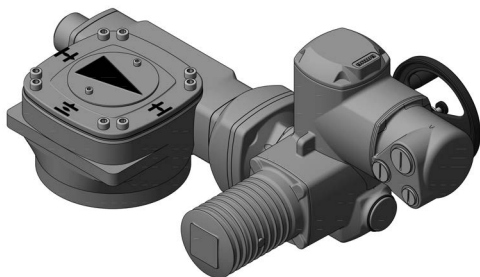

Electric actuators are mostly a combination of a gear box and an electrical motor. Electric power generates a torque which operates the valve. These actuators are flexible and economical. They can be installed where no air supply is available. They can also be equipped with several electrical accessories, including special control units that make them smart with bus interfaces.

Automation

Heating Jacket



Welded Bottom Cover For Hazardous & Toxic Media



Single Packing With Pressure Tight Bearing & Monitoring Port

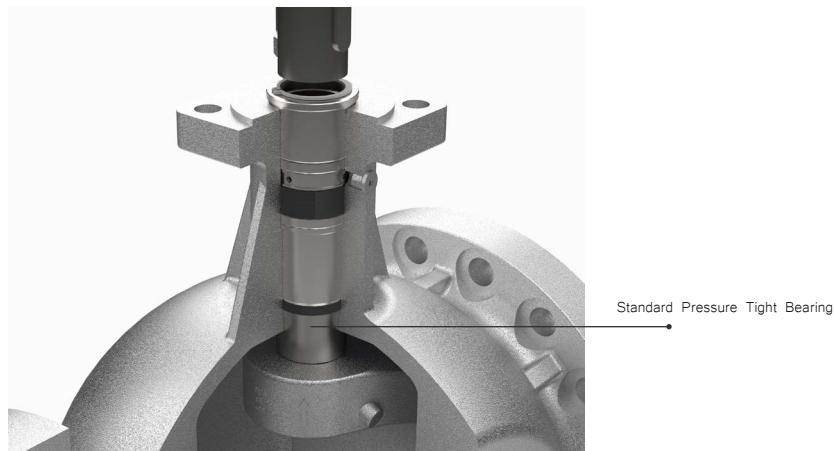

A photograph of an industrial facility, likely a refinery or chemical plant, featuring a complex network of silver pipes, metal walkways, and a tall distillation column. A yellow crane is visible at the top of the column. The scene is set against a clear blue sky. A semi-transparent dark blue rectangular box is overlaid on the left and center of the image, containing white text.

**CRANE® FK-TRIEX™ IS AN
INNOVATIVE SOLUTION THAT
PROVIDES BI-DIRECTIONAL
SHUTOFF, SUPERIOR FUGITIVE
EMISSIONS CONTROL, EASE OF
SERVICEABILITY, LESS WEIGHT, AND
LOW TOTAL COST OF OWNERSHIP.**

CRANE[®]

CRANE CHEMPHARMA & ENERGY

Xomox International GmbH & Co. OHG
Von-Behring-Straße 15
88131 Lindau (Bodensee)
Deutschland
Tel.: +49 8382 702-0

4526 Research Forest Drive,
Suite 400
The Woodlands
Texas 77381, U.S.A.
Tel.: +1 936 271 6500

ARMATURE d.o.o.
Koroška cesta 55
2366 Muta,
Slovenia
Tel.: +386 2 87 70 500

Crane Company, and its subsidiaries cannot accept responsibility for possible errors in catalogues, brochures, other printed materials, and website information. Crane Company reserves the right to alter its products without notice, including products already on order provided that such alteration can be made without changes being necessary in specifications already agreed. All trademarks in this material are the property of the Crane Company or its subsidiaries. The Crane and Crane brands logotype (ALOYCO[®], BAUM[®], CENTER LINE[®], CRANE[®], CRANE CRYOGENICS[™], CRYOWORKS[®], DEPA[®] & ELRO[®], DOPAK[®], DUO-CHEK[®], FLOWSEAL[®], GYROLOK[®], GO REGULATOR[®], HOKE[®], JENKINS[®], KROMBACH[®], NOZ-CHEK[®], PACIFIC[®], RESISTOFLEX[®], XOMOX[®], SAUNDERS[®], STOCKHAM[®], TECHNIFAB[®], TEXAS SAMPLING[®], WESTLOCK[®], WTA[®], and XOMOX[®]) are registered trademarks of Crane Co. All rights reserved.