

CRANE® FK-TrieX™- Full Port Triple Offset Isolation Valves For Severe Service

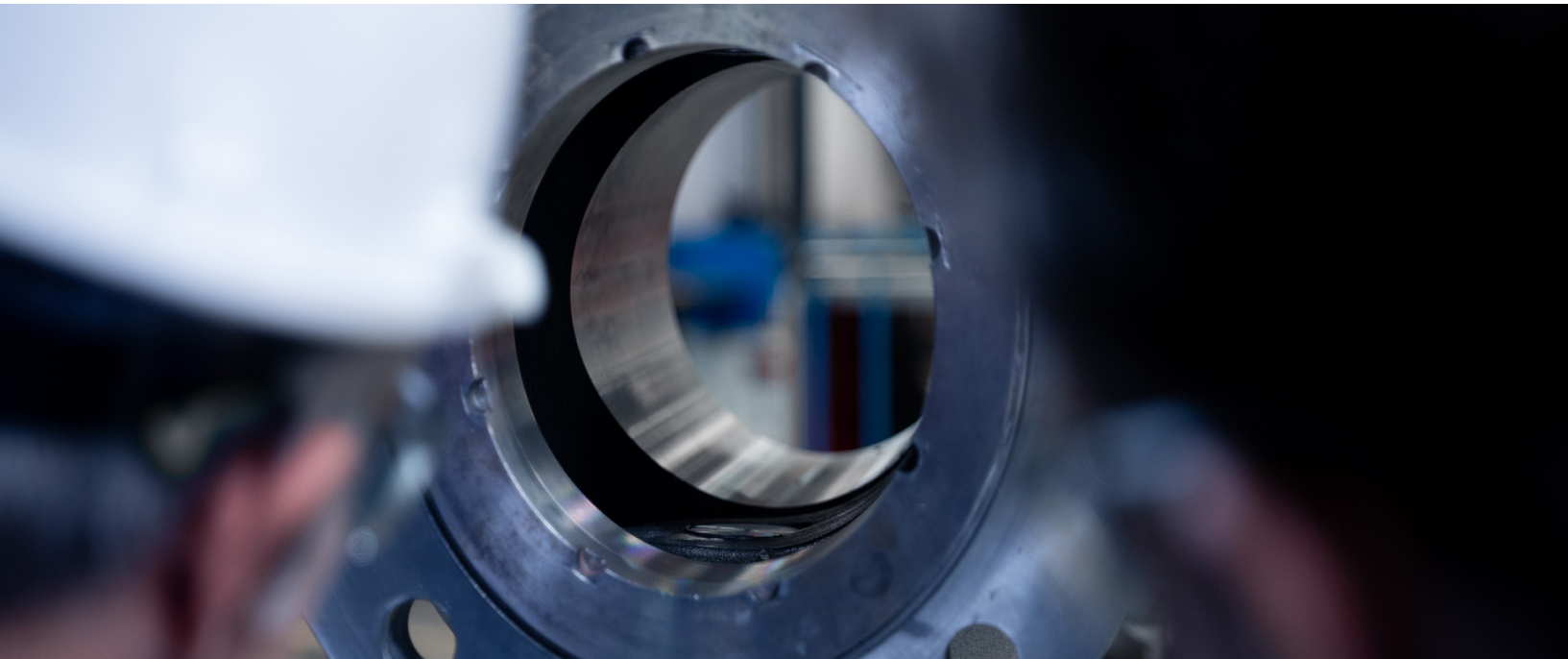

NEW! HIGH Cv VALVE PERMITS LINE SIZE REDUCTION

For severe service applications where safety, reliability, and efficient operation are paramount, the new FK-TrieX provides:

- ✓ bi-directional bubble tight shutoff
- ✓ high reliability
- ✓ superior fugitive emissions control
- ✓ ease of serviceability
- ✓ less weight, low torque actuation
- ✓ low total cost of ownership

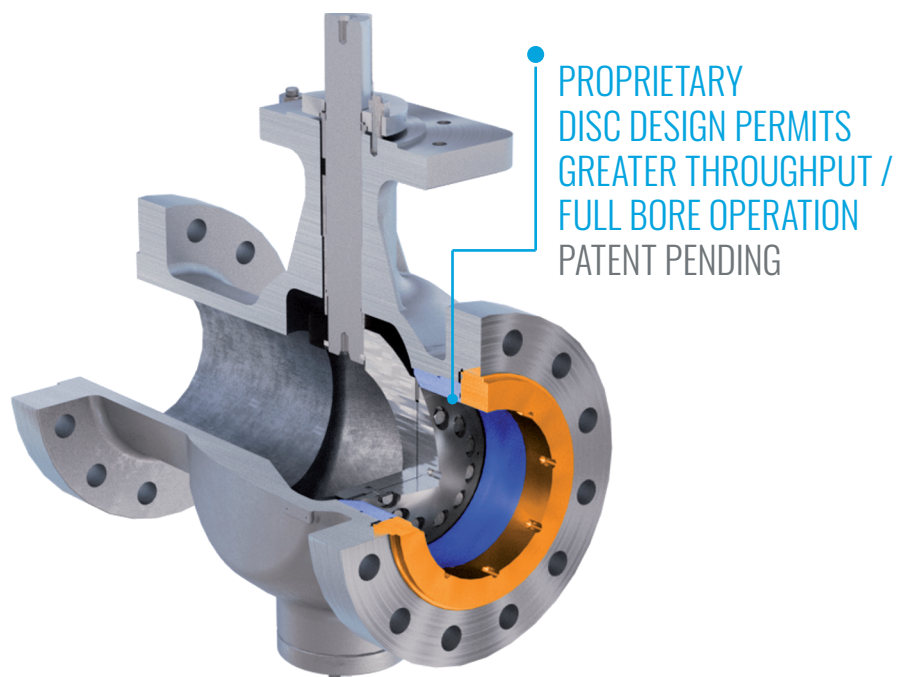

CRANE® FK-TrieX™ Features and Benefits

1 SAFETY

With CRANE® FK-TrieX™ severe service isolation valves, you can run safe & environmentally responsible operations, prevent high consequence incidents including fire, explosion & leakages, and eliminate risk to health & safety of employees, assets & communities. Design of CRANE® FK-TrieX™ minimizes fugitive emissions that is not only a safety risk but is also a significant contributor (5.2 ~ 12%) to global greenhouse gas emissions.

2 RELIABLE OPERATIONS

Fluid leakage through the valve can impact the quality and delivery of your products. CRANE® FK-TrieX™ features repeatable bidirectional bubble-tight shutoff that can help you achieve higher product output by reducing unplanned shutdowns from valve failures and by reducing planned valve maintenance time by more than 50%. When necessary, the ability to field repair the seats ensures minimal downtime.

3 LOW OVERALL COST

CRANE® FK-TrieX™ enhances long term value of your investment. Relative to existing technologies, you can realize both upfront and long-term cost savings in the form of smaller actuators, 20% lower structural support cost, >50% reduced cost of planned maintenance due to modular seat design and minimal product wastage cost. This high Cv valve permits reduction in line size when replacing butterfly valves.

Operate Your Plants Safely	Reliable Operations	Lower Overall Cost
<p>1. Proven Triple Offset Sealing Provides repeatable bi-directional bubble-tight shutoff</p> <p>2. Torque Assisted Seating Yields a better seal due to evenly distributed compression of the seal along the entire sealing area</p> <p>3. Superior Fugitive Emissions Control Per ISO 15848-1 AH CO3 & API 641</p> <p>4. Fire Safe Design Per API 607 standard</p>	<p>5. Frictionless Sealing Minimizes wear that is typically seen in other technologies due to spring force or other impinging force on seat</p> <p>6. Replaceable Stellite Welded Seat & Flexible Laminate Seats Provide excellent shutoff and 2x life than stainless seats. 40 RC hardness rating</p> <p>7. Cavity-less Self-Cleaning Design Ensures solids do not get trapped in valve crevices eliminating premature failure</p> <p>8. API 6D Standard Full-Bore Design Allows Pipeline Inspection Gauges (PIGs) and cleaning scrapers to pass through the valve in full open condition</p> <p>9. Optimal Flow Profile In addition to standard full-bore design provides high Cv and low pressure drop</p>	<p>10. Modular Seat Design Enables replacement of seat (TrieX ring) and laminate seals without having to replace the entire valve</p> <p>11. Field Replaceable Seat & Seal Provides the ability to replace the seat (TrieX ring) and laminate seals in field without having to ship the valve to service centers</p> <p>12. Quarter Turn Design Eliminates the need for complex and oversized actuators</p> <p>13. Single Piece Body Eliminates additional leak path to atmosphere. Reduces weight by 10% thereby reducing structural support costs</p> <p>14. Same Face to Face Dimensions as other technologies ASME B16.10 Long Pattern</p>

Materials of Construction

- Standard: A216 Gr. WCB, A351 Gr. CF8M; LCC, Monel®
- Options upon request: Duplex, Superduplex, LCB, WC6, CF3M, Inconel®, Hastelloy®, Alloy 20

Size Range

- 6" up to 36" in a single piece cast body design

Pressure Ratings

- ASME Class 150, 300, 600

Temperature Range

- -76°F up to 1022°F; -60°C up to 550°C, depending on material

Body Configurations

- ASME B16.10: Double Flanged Long

Standard Options

- Pressure Tight Bearing Design

Typical Applications

- LNG
- Molecular Sieve Packages
- CHEMICAL
- VCM/VCI Units
- MDI/PMDI Units
- Ethane Cracker
- REFINING
- FCC/CCR Units
- Distillation Units
- Hydrocracker Units
- MIDSTREAM PIPING
- Re-energization Stations
- Piping

