

CRANE

CRYOFLO H₂

Keeping Cryogenics Cool

INSTALLATION, OPERATION, AND MAINTENANCE MANUAL

**CRANE™ CRYOFLO™ Valves
For Liquid Hydrogen**

CRANE



















www.cranecryoflo.com
IOM-CRYOFLO VALVES-001 REV 02

Table of Contents

| TABLE OF CONTENTS | |
|--------------------------|--|
| SECTION A | General Valve Installation, Operation, & Maintenance Information |
| SECTION B | Hydrogen Service Valves |
| SECTION C | Bellow Seal T-Globe Valves |
| SECTION D | Bellow Seal Y-Globe Valves |
| SECTION E | Lift Check Valves |
| SECTION F | Appendix on Bolting Torques |
| SECTION G | Appendix on Long Term Storage |
| SECTION H | Appendix on Valve Installation |
| SECTION I | Appendix on Gasket Maintenance and Valve Lubrication |













General Warnings & Information

Section A

| | |
|--|---|
|  CAUTION | The operator of any valve should have an understanding of the effects of opening/closing the valve with regards to its role in the overall piping system. Operators of valves under pressure should take caution to ensure that the valve is in good operating condition prior to operating it under pressure. |
|  WARNING | All cryogenic liquids are extremely cold. Cryogenic liquids and their vapors can rapidly freeze human tissue. Use appropriate personal safety equipment while operating the valve. |
|  WARNING | Certain processes utilize flammable, caustic and/or otherwise unstable media. Care should be taken in these circumstances to ensure the operator is aware of the specific health and safety risks associated with that media. |
|  CAUTION | All piping systems should contain independent support mechanisms and should not utilize the valve as a sole means of support. |
|  CAUTION | The estimated total lifespan of a CRANE CRYOFLO valve when installed within ideal boundary conditions is 5 years or 3000 cycle whichever is earlier. |
|  CAUTION | All valve actuators shall be sized by referring to the specific relevant valve torque and thrust data published by CRANE CRYOFLO Valves. Generic or standard valve information shall not be used. |
|  CAUTION | It is the ultimate responsibility of the piping designer to ensure that each valve is specified appropriately for the given system parameters. This includes, but is not limited to: pressure, temperature, flow rate, velocity, pressure drop, and material compatibility with process media. Additionally, it is the responsibility of the piping designer to ensure that the corresponding actuator sizing data is correct for the given application. |
|  CAUTION | During throttling application, do not operate the globe valve continuously at less than 10% open. |
|  CAUTION | All valves shall only be used within their defined boundary conditions. All standard materials of construction, including bolting are suitable for operation within the boundary conditions listed in section 8.0 of this document. Care should be taken to ensure that all valves are not operated at conditions that exceed or deviate from the defined boundary conditions. The boundary conditions must be adhered to regardless of the piping system status, including but not limited to: Start-up, hydro-testing, chemical cleaning, system flushing, etc. |
|  WARNING | Care should be taken around all valves as injury or damage may occur from the leakage of cryogenic fluid. |
|  CAUTION | It is the responsibility of the user/owner of a plant to ensure that all valve operators are ordered to meet all applicable requirements and specifications. |
|  WARNING | Only valves that have been certified as fire safe shall be used in piping systems that may be exposed to fire. |
|  WARNING | When operating manual valves, gloves should be worn to minimize the risk of injury to the hands. Operators shall wear the appropriate PPE when working with such media. |
|  CAUTION | In situations where manual valves are difficult to operate due to substantial torque requirements, it is recommended that the valve be supplied with a gear or motor operator. |
|  CAUTION | All valves should be mounted with the stem vertical or 45° inclined to the pipeline horizontal. |
|  CAUTION | Depending upon the specific application, normal lubricants shall not be used for cryogenic temperature. In this case cryogenic temperature lubricants shall be used in place of the standard type. |
|  CAUTION | Contact CRANE CRYOFLO prior to any changes. |

General Warnings & Information

Section A

| | |
|--|---|
|  CAUTION | Read this Operations and Maintenance Manual before installing, removing, or repairing any CRANE CRYOFLO valves. Failure to do so may result in improper valve function, void of manufacturer's warranty, bodily harm, or fatal injury. |
|  CAUTION | All CRANE CRYOFLO Valves are designed and manufactured to be installed in applications where no more than 1g of force in excess of gravity is applied to the valve in any direction. This 1g force can be an effect of Traffic, Wind or Earthquake. CRANE CRYOFLO Valves should not be used in applications that exceed 1g. |
|  CAUTION | When a CRANE CRYOFLO valve with an actuator is installed on a trailer/truck, the piping engineer shall ensure that the actuator is supported properly. |
|  CAUTION | All piping system components are subject to certain levels of erosion and corrosion. As the valve wall thickness is the governing variable in overall service life, care should be taken to ensure that all valves and related piping components are of a suitable wall thickness for the given application. Periodic inspections should also be made as valves/components may wear over time. As a minimum, annual inspection of valve body and bonnet wall should be performed with calibrated measuring devices such as micrometers and/or ultrasonic thickness gauges. Severe applications may require additional inspection types and/or frequency. Additionally, valves should be inspected for general signs of component wear and/or damage caused by process media. This may include the removal of insulation and/or jacketing to ensure a proper inspection. All valves should also be cycled completely during these inspections to ensure proper operability. Care should be taken to ensure that this will not affect the operating system. |
|  CAUTION | All CRANE CRYOFLO valves are designed for operation in clean media. These media should be free of all debris and particulate matter. Debris in the media may cause damage and/or reduced performance to the valve. |
|  CAUTION | The style, size, pressure class and material selection of all valves is the responsibility of the piping system designer. CRANE CRYOFLO Valves may offer suggestions in this area, however the selection process is solely the responsibility of plant designers. Plant designers should also take into account the specific effects that the process media will have on the valve wall thickness and corresponding service life and ensure that the selected material is compatible with the process media. See Table 1 for wall thickness. It is also the responsibility of the piping designer to ensure that valves are equipped with any necessary venting. |
|  WARNING | Do not exceed 100% of the maximum pressure rating of the valve at any time during its operation. Pressure spikes beyond the valve's pressure rating are solely the responsibility of the user. Doing so may result in improper valve function, void of manufacturer's warranty, bodily harm, or fatal injury. |
|  WARNING | When operating any valve, operator shall keep safe distance from moving parts such as the stem. |
|  CAUTION | All Handwheel operated CRANE CRYOFLO valves are designed for hand input. Do not apply excessive input torque when an extended pipe wrench, "Helper Bar" or other devices are used. Excessive input torque can damage seat or other internal parts of valve. |
|  CAUTION | Motor operated valves should be left in their factory set condition, unless the system operating parameters dictate a change. If changes are necessary, they should be performed in small increments and then the valve operation inspected. When adjusting these settings, use only the lightest/lowest setting possible to achieve the desired performance. Excess torque and/or thrust in the motor settings may damage or lockup the valve. |
|  WARNING | Never remove a motor operator, gear operator or manual operating assembly from a valve while it is pressurized. The valve must be completely relieved of all pressure prior to this disassembly. |
|  CAUTION | Care should be taken to ensure that electrical motors are wired correctly to the power source. Incorrect phasing of wiring may cause valve/motor damage. |

1.0 THEORY OF OPERATION

T-Globe Valves. Globe valves are designed to close off, open up or throttle the flow in a pipeline. The disc is designed to completely stop flow and form a tight seal with pressure under the disc. In the 10% open position to full open position, globe valves are effective in throttling line pressure.

| | |
|--|---|
|  CAUTION | Continuous throttling at less than 10% open may cause excessive vibration, noise, wear and damage to discs and seats. |
|--|---|

Y-Globe Valves. Y-Globe valves are designed to close off, open up or throttle the flow in a pipeline. The disc is designed to completely stop flow and form a tight seal with pressure under the disc. In the 10% open position to full open position, globe valves are effective in throttling line pressure.

| | |
|--|---|
|  CAUTION | Continuous throttling at less than 10% open may cause excessive vibration, noise, wear and damage to discs and seats. |
|--|---|

Lift Check Valves. Lift check valves are designed to be opened by the flow of system pressure in one direction and close automatically when the system flows in the opposite direction.

2.0 DESCRIPTION

This manual covers CRANE CRYOFLO T-Globe, Y-Globe, and Lift-Check valves. These valves are designed according to ASME B16.34 & MSS SP 134 and are designed to operate at Maximum Allowable Working Pressure (MAWP) of 300 psi. See Section 5.0 for operation of valves. This manual is for reference purposes only. Disassembly and maintenance of valves should only be performed by qualified personnel. Consult CRANE CRYOFLO Valves for specific technical support.

3.0 INSTALLATION

When unpacking, care should be exercised in lifting and handling to avoid damage to valves or injury to personnel. For specific installation information, refer to section "H" of this manual.

| | |
|--|---|
|  CAUTION | Do not lift any valve by the handwheel or stem. Use lifting lugs or straps around the valve body. Doing so may cause damage to the valve. |
|--|---|

All CRANE CRYOFLO valves are designed to function in a single direction (Globe & check valves, etc.) All markings should be noted on the valves. Arrows on the valves indicating flow direction should correspond with the system flow direction.

Always install the Lift Check Valves at a distance of 10 times pipe diameter or more from upstream elbows for optimum performance. Do not remove protective end coverings until immediately prior to valve installation. When installing, ensure that all foreign material is removed from the interior of the valve, including desiccants. Align pipe and weld end of valve and complete the welding.

Check the temperature of surrounding areas to avoid heating valve body excessively, especially with small sizes, where heat sink may be necessary

For flanged valve, inspect gasket compression surfaces of valve and pipe flange for any scratches or damages. Align bolt holes of pipe flange & valve. Insert gasket between pipe valve & flange and tighten the fasteners. It is recommended that fasteners shall be lubricated.

| | |
|--|---|
|  CAUTION | The temperature of the valve body should not exceed 200°F during welding to void damaging the soft seals. |
|--|---|

Use the smallest electrodes and the minimum amperage possible consistent with approved welding procedures. This will help to minimize warpage in the seat areas. All Valve Bodies are Stainless Steel. Therefore, care should be taken not to over-heat Valve Body beyond that required for normal welding.

When the valve is to be installed in a vacuum jacketed system, care should be taken in the jacket design to prevent forces on the Bonnet of the Valve caused by differential contraction rates (thermal loads) between the inner process line and the vacuum jacket. Contact CRANE CRYOFLO for assistance.

It is recommended that pipeline should be flushed post welding. Valve should be kept in fully open position during flushing. Cycle globe valve 3 to 5 times post flushing.

| | |
|---|--|
|  CAUTION | Ensure that all foreign material (dirt, weld slag, etc.) has been removed from the valve & pipeline prior to and after installation. Foreign material is the primary cause of premature seat failures. |
|---|--|

4.0 WARRANTY

All CRANE CRYOFLO valves are backed by a full manufacturer's warranty against defects in materials or workmanship. It should be noted that any work or modification performed on a CRANE CRYOFLO valve must be authorized by CRANE CRYOFLO to retain the original factory warranty.

5.0 OPERATING INSTRUCTIONS

CRANE CRYOFLO valves are designed for simplicity and ease of operation. To open a globe valve, turn the handwheel in a counterclockwise direction; continue turning until interference is felt; at this point, the valve will be fully open. To close the valve, turn the handwheel in a clockwise direction; continue turning until interference is felt; at this point, the valve will be fully closed.

CRANE CRYOFLO valves equipped with Pneumatic Spring-Diaphragm or single-acting piston actuators with fail-close can be operated by applying air pressure to the lower chamber, which moves valve stem in upward direction thus opening the valve disc. If air pressure supply fails, the spring in the actuator moves valve stem in a downward direction thus providing fail-closed action. CRANE CRYOFLO valves equipped with Pneumatic Spring-Diaphragm or single-acting piston actuators with fail-open can be operated by applying air pressure to the upper chamber, which moves valve stem in the downward direction thus closing the valve disc. If air pressure supply fails, the spring in the actuator moves valve stem in an upward direction thus providing fail-open action. Refer to the provided actuator schematic for further information.

In case of bare stem valves where actuator will be assembled by end user ensure that,

1. Thrust generated by actuator is sufficiently above the thrust required to seal the valve.
2. Torque applied by actuator/gearbox shall not exceed the Maximum Allowable Stem Torque as this may lead to failure of valve stem. Contact CRANE CRYOFLO for assistance.

Lift check valves are designed to be operated by line pressure only. When the upstream line is pressurized, flow will open the disc. When the upstream line pressure is reduced, or if there is backpressure, the disc will close.

6.0 PREVENTATIVE MAINTENANCE & PERIODIC INSPECTION

It is recommended that periodic inspections be made of all CRANE CRYOFLO valves. The frequency of these inspections will vary, depending upon the severity of service and frequency of operation of the valve. As a minimum, all valves should be checked quarterly/around 500 operating cycles to ensure proper operation and discourage the damage compounding effects of leakage and reduced performance. The following list details the specific valve types and areas requiring inspection and maintenance.

| ITEM TO INSPECT | GLOBE | LIFT CHECK |
|--|-------|------------|
| Check stem threads for wear | X | |
| Check for Gland O-ring leaks | X | |
| Check body/bonnet joint for leaks | X | X |
| If conditions permit, operate valve. | X | |
| Inspect all external connections | X | X |
| Ensure Stem and seal areas are free from debris | X | X |
| Check all lubrication points | X | |
| Inspect condition of motor and/or gear operators (when used) | X | |
| Inspect valve for obvious damage | X | X |

| | |
|---|--|
|  WARNING | Do not disassemble or modify a CRANE CRYOFLO valve in any way prior to installation. This will void the factory warranty if it occurs. |
|---|--|

With proper care, the Valve Assembly should require very little maintenance; however, as with all cryogenic equipment, thorough inspection of the system should be performed periodically to ensure continued, reliable operation.

Any type of maintenance activity must not be performed on CRANE CRYOFLO valves while the valve is pressurized.

7.0 IDENTIFICATION

All CRANE CRYOFLO valves are identified with a metal tag that is hung using a stainless-steel wire as not to damage the valve jacket. The tag is usually found on the body/bonnet joint area, or on the top plate area near the handwheel.

When performing any work, ordering spare parts, or requesting technical support, please refer to this tag. The Serial Number (2) is the key to proper valve identification.

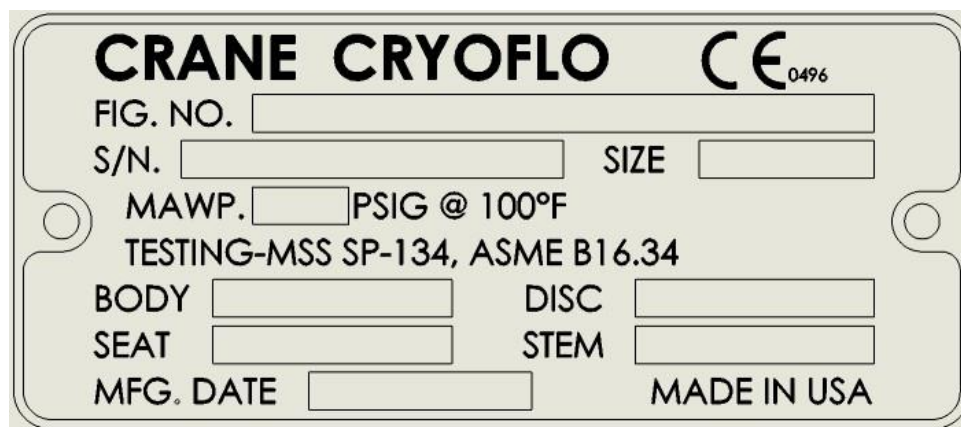

Tag Example 1

| EXPLANATION OF TAG MARKINGS | | |
|-----------------------------|-------------|--|
| 1 | FIG. NO. | Figure number identifying valve selections |
| 2 | SERIAL NO. | Unique number identifying a single valve |
| 3 | SIZE | Nominal pipe size (NPS) of the valve |
| 4 | MAWP | Maximum Allowable Working Pressure (Example: 300psi) |
| 5 | TEMP. RANGE | Temperature Range: (Example: -424°F to 100°F) |
| 6 | BODY | Body ASTM material grade designation |
| 7 | DISC | Disc or Wedge trim material |
| 8 | SEAT | Seat Material |
| 9 | STEM | Stem Material |
| 10 | DOM | Date of Manufacturing |

General Warnings & Information

Section A

7.1 Figure Number definition for CRANE CRYOFLO™ Globe & Check valves

| CFH1 | T | 3 | A | Q | 1 | A | HW | V | ST |
|-----------|-----------|-----------|----------|-------------------|--------------------|------------------------|----------------|----------------|--------------------------|
| 1 SIZE | 2 TYPE | 3 MAWP | 4 MOC | 5 DISC TYPE | 6 GASKET MOC | 7 END CONNECTION | 8 ACTUATION | 9 JACKETING | 10 SPECIAL FEATURE |

| | | | | | | | | | |
|----|-----------------|---|--|-------------------------------------|--|--|--|--|--|
| 1 | Size | CF0H - 1/2" CF0Q - 3/4" CF01 - 1" CF1Q - 1 1/4" | CF1H - 1 1/2" CF02 - 2" CF2H - 2 1/2" CF03 - 3" | CF04 - 4" CF05 - 5" CF06 - 6" | | | | | |
| 2 | Valve Type | T – Bellow Seal T-Globe Valve Y – Bellow Seal Y-Globe Valve L – Bellow Seal Lift Check Valve R – Bellow Seal Angle Valve | | | | | | | |
| 3 | MAWP | 1 - 150 psi 3 - 300 psi 6 – 600 psi | | | | | | | |
| 4 | MOC | A - CF8M body, 304ss Disc, 304/304L pipe B - CF8M body, 304ss disc, 316/316L pipe C - CF8M body, 316disc, 316/316L disc & pipe D - CF3M body, 316Lss disc & pipe | | | | | | | |
| 5 | Disc Type | Q - PCTFE, Quick opening L - PCTFE, Linear E - PCTFE, Equal Percent | | | | | | | |
| 6 | Gasket Material | 1 - Graphite 2 - PTFE | | | | | | | |
| 7 | End Connection | A - Pipe Sch. -10, B - Pipe Sch. 5, C -Pipe Sch. 40, D -Pipe Sch. 80, F - Flat Face Flanged H - Hub Ends, R - RF Flanged, 125-250 Ra, S - Socket, pipe, T - Socket, tube, U - Butt Weld Schedule 5, V -Butt Weld Schedule 10, W - Butt Weld Schedule 40, X – Custom, Y - Butt Weld Schedule 80, Z – RTJ | | | | | | | |
| 8 | Actuation Type | HW = Handwheel BS = Bare Stem A1 to Z9 = Pneumatic Actuators 01 to 99 = Electric Actuators 00 = None (Lift Check) | | | | | | | |
| 9 | Jacketing | N - Non-Jacketed V - Vacuum Jacketed, Insulated for H2 J - Vacuum Jacket parts provided | | | | | | | |
| 10 | Special Feature | ST - Manufacturer standard bonnet length, non-cold box S2 - Manufacturer standard bonnet length, non-cold box, O2 Clean CL - Custom bonnet length XX - Special or multiple custom requirements MC - Cold box, non-O2 Clean M2 - Cold box, O2 Clean | | | | | | | |

General Warnings & Information

Section A

7.2 Cartridge Kit Order Information for CRANE CRYOFLO™ Globe & Check valves

| RC | 1H | T | 3 | Q | 1 | A | 1 | X | S2 |
|--------------------------------|-----------|--------------------------|------------|-----------------------|------------------|--|--------------------|--------------|------------------------------|
| 1 REPLACEMENT CARTIRIDGE | 2 SIZE | 3 TYPE OF VALVE | 4 CLASS | 5 RETAINER TYPE | 6 DISC MOC | 7 BELLOW SUBASSEMBLY / STEM MOC | 8 GASKET MOC | 9 DEFAULT | 10 SPECIAL ADD- ONS |

| | | |
|----|-------------------------------|---|
| 1 | Replacement Cartridge | RC=Replacement Cartridge |
| 2 | Size | 1/2" = 0H 3/4" = 0Q 1" = 01 1.5" = 1H 2" = 02 3" = 03 4" = 04 6" = 06 |
| 3 | Type of valve | T = Bellow Seal T&Y Globe L = Bellow Seal Lift Check |
| 4 | Class | 1 = 150 3 = 300 6 = 600 |
| 5 | Retainer Type | Q =Quick opening L = Linear E = Equal Percent X-Not Applicable (Lift Check) |
| 6 | Disc MOC | 1 = 304SS 2 = 316SS 3 = 316LSS |
| 7 | Bellow Subassembly / Stem MOC | A= 1.4404 B = 316SS C = 316/316L Dual Grade |
| 8 | Gasket MOC | 1=SWG SS316+Graphite+PTFE |
| 9 | Default | Default |
| 10 | Special Add-ons | S2 - Manufacturer standard bonnet length, Non-cold box, O2 Clean CB = Cold Box Cuff, O2 Clean CL = Custom bonnet length, Specified by End User, O2 Clean XX = Special or multiple custom requirements, O2 Clean M2 = Cold box, O2 Clean |

General Warnings & Information

Section A

7.3 Soft Goods Kit Order Information for CRANE CRYOFLO™ Globe & Check valves

| | | | | | | | | | |
|-----------------|-----------|--------------------------|------------|------------------------------|--------------------|-----------------|----------------|--------------|---------------------|
| SG | 1H | T | 3 | A | 1 | C | HW | X | SG |
| 1 SOFT GOODS | 2 SIZE | 3 TYPE OF VALVE | 4 CLASS | 5 SEAT MATERIAL MOC | 6 GASKET MOC | 7 O-RING MOC | 8 ACTUATION | 9 DEFAULT | 10 SOFT GOODS |

| | | |
|---|-------------------|--|
| 1 | Soft Goods | SG=Soft Goods |
| 2 | Size | 1/2" = 0H 3/4" = 0Q 1" = 01 1.5" = 1H 2" = 02 2.5" = 2H 3" = 03 4" = 04 6" = 06 |
| 3 | Type of valve | T = Bellow Seal T&Y Globe L = Bellow Seal Lift Check |
| 4 | Class | 1 = 150 3 = 300 6 = 600 |
| 5 | Seat Material MOC | A = PCTFE |
| 6 | Gasket MOC | 1=SWG SS316 + Graphite + PTFE |
| 7 | O-ring MOC | C = Viton X = None (For Lift Check) |
| 8 | Actuation | HW = Handwheel BS = Bare Stem A1 - Z9 = Pneumatic Actuators 01 - 99 = Electric Actuators "None = 00 (For Lift Check)" |
| 9 | Default | Default |

7.4 The following chart denotes the appropriate maintenance manual section for a given valve figure number/style. Please note that the sections listed are the specialized sections only and pertinent general valve information is contained in other sections of this manual. Please refer to table of contents for total listings.

| CRYOFLO GLOBE VALVE | | MANUAL SECTION |
|---------------------|---------------------------|----------------|
| MAWP300PSI | BELLOW SEAL T-GLOBE VALVE | C |
| MAWP300PSI | BELLOW SEAL Y-GLOBE VALVE | D |
| MAWP300PSI | LIFT CHECK VALVE | E |

8.0 BOUNDARY CONDITIONS

The following chart denotes the defined boundary conditions for all CRANE CRYOFLO valve products

| BOUNDARY CONDITIONS BELLOWS SEAL T&Y GLOBE VALVE | |
|---|--|
| Scope of product: | 1/2" through 6" MAWP 300 psi |
| Service fluid: | <ul style="list-style-type: none"> LIN, LOX, LAR, LH2, LHe and LNG. No suspended solid material greater than 100 microns |
| Service Life: | 5 years or 3000 Operation Cycle whichever is earlier. Can extend service life 2-3 fold by replacing Cartridge Assembly. Normal maintenance parts such as seals, gaskets and parts that move relative to each other e.g. seats & stems. |
| Allowable pressure and temperature: | 300 psi & -253°C to 100°C (-423°F to 212°F) respectively as manufacturer specification or refer to Tag Plate, PO, GAD or Datasheet. |
| Materials for pressurized parts: | Only materials approved under PMA by Accredited Notified Body may be used. See approved CE materials list. Appropriate material for service conditions to be based upon the following criteria: <ol style="list-style-type: none"> The design pressure and temperature An acceptable service life consistent with the corrosion rate of the material at design conditions. Expected operating conditions within the defined pressure cycles, thermal cycles and flow velocity limits. |
| Packing and gasket materials | To be compatible with expected operating conditions and fluid media |
| Method of operation: | <ul style="list-style-type: none"> Globe: Handwheel, pneumatic Actuator, Electrical Actuator Check: self-actuation |
| Frequency of operation: | <ul style="list-style-type: none"> Globe valves: not to exceed 20 times per week or 1000 per year Check: N/A |
| Installation orientation: | <ul style="list-style-type: none"> Globe: Valve neck vertical up to 45° inclined from vertical axis. Check: Flow horizontal in a horizontal pipe run; Valve neck vertical up to 30° inclined from vertical axis. |
| Flow velocity: <ul style="list-style-type: none"> To keep noise and erosion at or below reasonable levels, valves are not to be used for throttling service, and velocity is not to exceed the values shown in table to right. Check valves should operate at or above the velocity indicated to stabilize the disc and avoid premature wear. | Maximum flow velocity for Globe valves: $T\text{-globe} = 180\sqrt{V^-}$ ft/sec or 50 ft/sec, whichever is lowest. $Y\text{-globe} = 200\sqrt{V^-}$ ft/sec or 50 ft/sec whichever is lowest. Where V^- = Specific volume of flowing medium in ft ³ /lb. |
| Functional test: | Shell Test: 1.5 times of MAWP 300psi for the body material Seat Test : 1.1 times of MAWP 300psi for the body material |
| Pipe & support reactions: | All reaction loads transmitted through valve ends. Cross section and Moment of Inertia of valve ends to be greater than that of the connecting pipe. |
| External fire capability: | Not suitable for sustained external heat source greater than 193°C (380 °F). |
| Seismic rating: | 1 g load in any direction. |
| Vent method: | NPT Connection provided. |

**CRANE CRYOFLO™ Valves
Hydrogen Service Valves**



**Operations and Maintenance Manual
Crane CRYOFLO™**

4526 Research Forest Drive, Suite 400
The Woodlands, TX 77381

Phone: (936) 271-6500
www.cranecryoflo.com

Hydrogen Service Valves



Section B

1.0 GENERAL INFORMATION

- 1.1 The intent of this section is to detail specific issues regarding H2 service valves. For general information regarding this or any other valve please refer to "Section A" of this manual.
- 1.2 H2 valves are available in T & Y Globe configurations. Please refer to the appropriate section of this manual for specific information (Sections B & C).

| | |
|--|---|
|  WARNING | All cryogenic liquids are extremely cold. Cryogenic liquids and their vapors can rapidly freeze human tissue and can cause many common materials such as carbon steel, rubber, and plastics to become brittle or even break under stress. Cryogenic liquids in containers and piping at temperatures or below the boiling point of liquefied air [-318°F (-194°C)] can condense the surrounding air and can cause a localized oxygen enriched atmosphere. Extremely cold cryogens such as hydrogen and helium have the ability to freeze or solidify the surrounding air. |
|--|---|

2.0 MAINTENANCE

| | |
|--|---|
|  WARNING | Do not permit smoking or open flames in any area where liquid/gases hydrogen is stored or handled. |
|  WARNING | Perform inspection of internal cavities of component for any erosion due to service. Which may result in failure due to hydrogen embrittlement. If observed, replace existing component with brand new component. |

- **H2 gas is extremely flammable. Follow all industry, local, and internal safety procedures when dealing with any valve or valve part that is intended for H2 service**
- **Before performing any work and/or disassembling any valve, ensure that all pressure has been removed from the line and from any cavities within the valve. Contact CRANE CRYOFLO before disassembling any valve.**
- **Avoid performing any maintenance activity while valve at cryogenic temperature.**
- **Prior to commencing with any internal work on H2 service valves, ensure that the entire valve has been properly neutralized.**

- 2.1 Personnel must be thoroughly familiar with the properties and safety considerations before being allowed to handle an H2 cryogenic liquid and its associated equipment.
- 2.2 Visually examine the entire valve, looking for any difference from the last examination. Make sure all bolted fasteners are in place and secure. Be sure the Hydrogen leakage indicating paint/tape shows no signs of discoloration.
- 2.3 As with any mechanical device, it is desirable to operate the valve at some regular frequency to keep moving parts free and operable. The frequency of operation depends on the condition of the system but should generally be not less than once a month or when system parameters allow.
- 2.4 On valves that are operated frequently (generally more than once per day), the Bonnet & handwheel threads should be examined regularly for signs of wear. Bonnet & handwheel threads on all CRANE CRYOFLO H2 gas valves are of the "ACME" thread form, which means that the top (or crest) of a new thread will have a flat surface. On a worn thread the flat surface tends to become pointed (knife edged) as the thread wears. Stems having sharply pointed or edged threads should be replaced.
- 2.5 Valves should be lubricated as necessary to maintain lubrication in the required areas. This includes the Bonnet & Handwheel threads. As a minimum, these points should be inspected and/or lubricated every 3 months.
- 2.6 Bonnet bolts are stressed during assembly at the factory, to the proper level to prevent leakage under any operating conditions within the valve rating. However, where conditions of extreme temperature fluctuations, heavy mechanical cycles or excessive vibration are present, retightening of the bonnet bolts may be necessary. If bolt tightening is necessary, please refer to section "F" of this manual.
- 2.7 Other threaded parts that should be checked regularly include the handwheel nut and Handwheel Stud. The handwheel nut is especially important when the valve is mounted with the stem in a non- vertical orientation, because a missing handwheel nut could result in the handwheel falling from the valve.

CRANE CRYOFLO™ Valves BELLOWS SEAL T-GLOBE VALVES



Operations and Maintenance Manual Crane CRYOFLO™

4526 Research Forest Drive, Suite 400
The Woodlands, TX 77381

Phone: (936) 271-6500
www.cranecryoflo.com

BELLOWS SEAL T-GLOBE VALVES

1.0 GENERAL INFORMATION

For general information regarding this or any other CRANE CRYOFLO valve please refer to "Section A" of this manual.

2.0 COMPLETE DISASSEMBLY

| | |
|--|--|
|  WARNING | Before disassembling any valve, ensure that all pressure has been removed from the line and from any cavities within the valve. Contact CRANE CRYOFLO valves prior to disassembling any valve. |
|--|--|

2.1 Handwheel Operated Valves

Upon completion of the disassembly procedure listed below, the handwheel (30) may be separated from the Bonnet (20), by removing the handwheel nut (31).

2.2 The following page contains a general disassembly and reassembly procedure. These procedures cover the bulk of the disassembly and reassembly process, however special attention should be paid to the following:

- a) Extreme care should be taken to ensure that the sealing surfaces of the gasket area do not become damaged during disassembly or reassembly. This includes scratches caused by misalignment and/or by debris in the seal area.

2.3.2 CRANE CRYOFLO recommends replacing the Bonnet joint gasket (18), O-Ring (19) and gland seal O-Ring (24, 25) when servicing any valve.

2.3.3 Caution should be exercised in handling the new Bonnet joint gasket (18), O-Ring (19) and gland seal O-Ring (24, 25) to avoid scratching its surfaces.

| | |
|--|--|
|  CAUTION | Caution should be exercised in handling the new Bonnet joint gasket (18), O-Ring (19) and gland seal O-Ring (24, 25) to avoid scratching its surfaces. Scratches in soft seal components may lead to valve leakage after reassembly. |
|--|--|

T-Globe: Part Identification

Section C

| PART IDENTIFICATION | |
|---------------------|------------------------------|
| 1 | BODY |
| 2 | BODY STUB PIPE |
| 3 | TOP PIPE FLANGE |
| 4 | BODY NECK PIPE |
| 5 | DISC |
| 6 | SEAT |
| 7 | SEAT RETAINER |
| 8 | SEAT CLAMPING SCREW |
| 9 | DISC NUT |
| 10 | SPLIT RING |
| 11 | LOWER STEM |
| 12 | PTFE SLEEVE |
| 13 | METAL BELLOWS |
| 14 | BELLOWS BOTTOM RING |
| 15 | ANTI ROTATION DEVICE |
| 16 | BELLOWS TOP RING |
| 17 | SLEEVE HOLDER |
| 18 | SPIRAL WOUND GASKET |
| 19 | O-RING |
| 20 | BONNET |
| 21 | UPPER STEM |
| 22 | SOCKET HEAD CAP SCREW |
| 23 | LOCK WASHER |
| 24 | O-RING |
| 25 | O-RING |
| 26 | GLAND BUSHING |
| 27 | HANDWHEEL BUSH |
| 28 | SNAP RING |
| 29 | HANDWHEEL STUD |
| 30 | HANDWHEEL |
| 31 | HANDWHEEL NYLON NUT |
| 32 | WASHER |
| 33 | STRAIGHT FITTING (VENT HOLE) |
| 34 | HANDWHEEL SLEEVE |
| 35 | GRUB SCREW |
| 36 | SNAP RING |

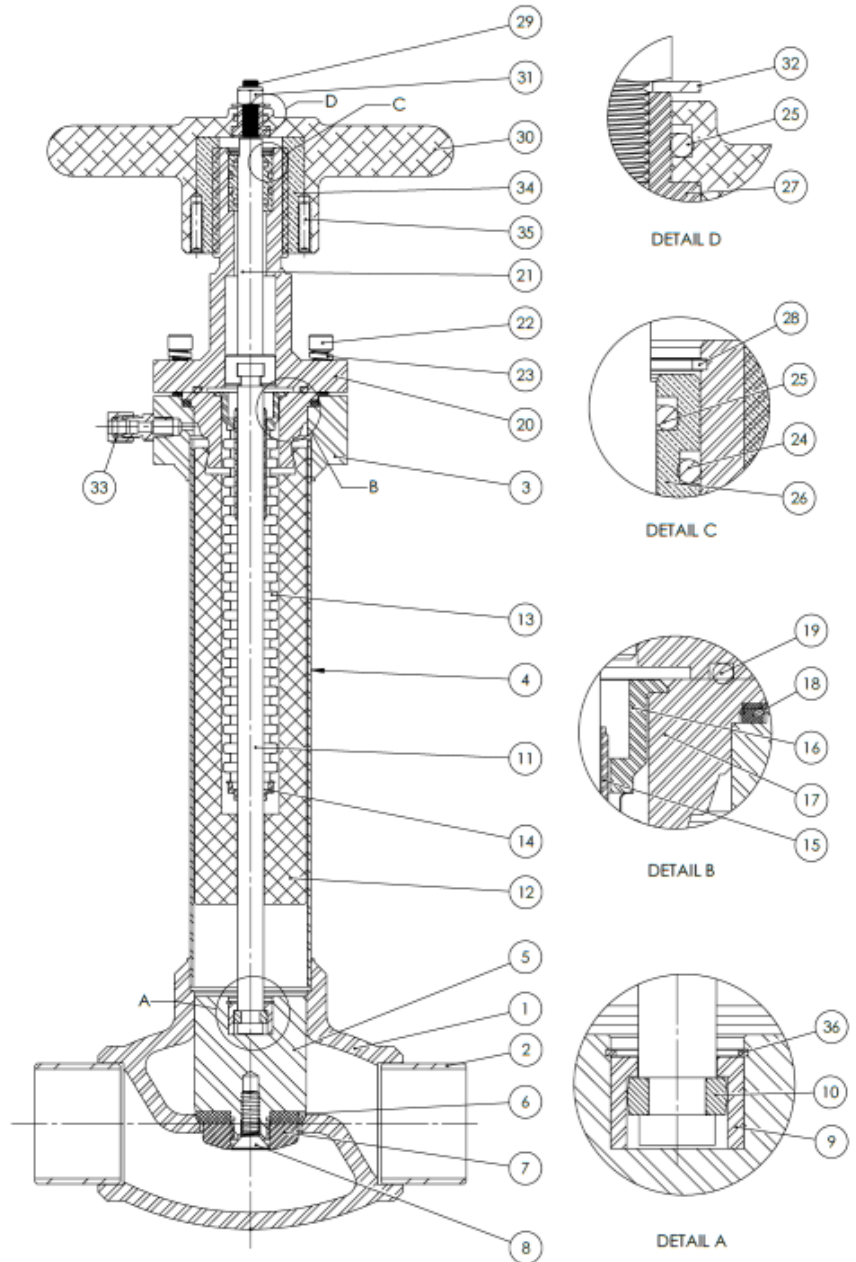

T-Globe: Disassembly & Reassembly

Section C

DISASSEMBLY

Read the warning notice listed in section 2.0 of these instructions.

1. Loosen Socket Head Cap Screw (22) and remove Bonnet Sub-Assembly (19+20+24+25+26+28). Follow below steps to dismantle the Bonnet Sub-Assembly.
 - I. Remove Bonnet Face O-Ring (19) and store in a clean area until ready to reassemble.
 - II. Remove Snap Ring (28) and Gland Bush (26).
 - III. Remove gland O-Rings (24 & 25); store in a clean area until ready to reassemble.
2. Remove Upper Stem Sub-Assembly (21+29).
3. Pull out Cartridge Sub-Assembly (5+6+7+8+9+10+11+12+13+14+15+16+17+36) from body. Follow below steps to dismantle the Cartridge Sub-Assembly:
 - I. Remove Snap Ring (36) and dismantle Disc Nut (9) and Split Ring (10) from Disc (5). Separate Disc Sub-Assembly and 'Stem, Bellows, and Sleeve Holder Weld-Assembly'.
 - II. Follow below steps to dismantle Disc Sub-Assembly (5+6+7+8) .
 - i. Loosen Seat Clamping Screw (8) and Seat Retainer (7).
 - ii. Remove Seat (6) from Disc (5).
4. Remove PTFE Sleeve (12) from 'Stem, Bellows, and Sleeve Holder Weld-Assembly'.
5. Remove Spiral Wound Gasket (18) from Bonnet. Never re-use a spiral wound gasket.

RE-ASSEMBLY

1. Clean all parts thoroughly. Clean gasket seating surface in the Body and Bonnet with fine emery cloth and isopropyl alcohol. Replace Spiral Wound Gasket (18) with a new factory supplied part.
2. Prepare Disc Sub-Assembly (5+6+7+8) per below steps:
 - I. Insert Seat (6) on Disc (5).
 - II. Tighten Seat Retainer (7) on Disc (5) by applying torque mention in Section-F.
 - III. Tighten the Seat Clamping Screw (8) on Disc (5) to secure Seat (6) and Seat Retainer (7).
 - IV. Apply a very thin film of Halocarbon 25-5S or Krytox®1 Grease to the O-Ring (19) and place in Bonnet groove.
3. Prepare Bonnet Sub Assembly (19+20+24+25+26+28) per below steps:
 - I. Insert O-Rings (24 & 25) in Gland Bushing (26) groove.
 - II. Insert Gland Bushing (26) with O-rings into Bonnet (20).
4. Insert Snap Ring (28) in Bonnet groove to prevent Gland Bushing's axial movement.
5. Insert PTFE sleeve (12) onto 'Stem, Bellows, and Sleeve Holder Weld-Assembly'.
6. Slide Snap Ring (36) and Disc Nut (9) on Lower Stem(11). Insert Split Ring halves (10) on Stem groove. Slide Disc Nut (9) over Split Rings (10) and insert entire sub-assembly into disc bore. Compress Snap Ring (36) into disc groove.
7. Insert Spiral Wound Gasket (18) into Top Pipe Flange groove.
8. Insert Cartridge Sub-Assembly (5+6+7+8+9+10+11+12+13+14+15+16+17+36) slowly from the top into the body.
9. Slide up Upper Stem Sub-Assembly (21+29) onto stem groove.
10. Assemble Bonnet Sub-Assembly by aligning Bonnet hole with threaded hole on Top Pipe Flange (5).
11. Apply appropriate lubricant on Socket Head Cap Screw (22) thread. Insert Lock Washer (23) on screw and tighten all Socket Head Cap Screws by following crisscross pattern and applying torque mention in Section-F.
12. Reassemble the Handwheel (30) on Bonnet (20) by applying the Handwheel Nut (31).

3.0 MAINTENANCE OF DISASSEMBLED VALVES

For general operation & maintenance information regarding this or any other CRANE CRYOFLO valve please refer to section "A" of this manual.

- 3.1 Following the above listed disassembly procedures, examine the Body (1) cavity for deposits of foreign material
- 3.2 Examine seating surfaces of in Body (1) and Seat (6) for wear.
- 3.3 Examine Bonnet (20), seal area, and threads for excessive wear.
- 3.4 If excessive wear is evident, worn parts (or if necessary, the entire valve) should be reconditioned or replaced
- 3.5 CRANE CRYOFLO offers complete replacement seal kits and spare parts for reconditioning. When ordering, always state the figure number (or stock number) of the valve and the body material.
- 3.6 CRANE CRYOFLO offers complete remanufacturing services to rework your valve. If you find this necessary, our nationwide network of Crane Valve Service Centers will remanufacture your valve to factory specifications.

4.0 SPARE PART REPLACEMENT

1. Cartridge Sub-Assembly (5+6+7+8+9+10+11+12+13+14+15+16+17+36) and Sealing Components Gasket and O-rings (18+19+24+25).
 - I. Follow Disassembly process mentioned above and replace Cartridge Assembly all part and perform reassembly of Valve.
2. Gland O-Ring Replacement
 - I. Read the warning notice listed in section 2.0 of these instructions.
 - II. Loosen Bonnet joint socket head cap screw (22) and remove Bonnet Sub-Assembly (19+20+24+25+26+28). Follow below step to dismantle Bonnet sub assembly.
 - III. Remove Bonnet Face O-Ring (19) and store in a clean area until ready to reassemble.
 - IV. Remove Snap Ring (28) and pull-out gland Sleeve (26).
 - V. Remove Gland O-Rings (24 & 25) and replace them with new O-Rings and reassemble valve in reverse order.
3. Bonnet O-Ring Replacement
 - I. Read the warning notice listed in section 2.0 of these instructions.
 - II. Loosen Bonnet joint socket head cap screw (22) and remove Bonnet Sub-Assembly (19+20+24+25+26+28).
 - III. Remove Bonnet Face O-Ring (19) and replace with new O-Ring and reassemble valve in reverse order.
4. Gasket Replacement
 - I. Read the warning notice listed in section 2.0 of these instructions.
 - II. Loosen Bonnet joint socket head cap screw (22) and remove Bonnet Sub-Assembly (19+20+24+25+26+28).
 - III. Remove upper stem sub assembly (21+29).
 - IV. Pull out entire Cartridge Sub-Assembly (5+6+7+8+9+10+11+12+13+14+15+16+17+36) from Body.
 - V. Remove Spiral Wound Gasket (18), replace with new Spiral Wound Gasket and reassemble valve in reverse order.
5. PCTFE seat replacement
 - I. Read the warning notice listed in section 2.0 of these instructions.
 - II. Loosen Bonnet joint socket head cap screw (22) and remove Bonnet Sub-Assembly (19+20+24+25+26+28). Follow below step to dismantle Bonnet Sub-Assembly.
 - i. Remove upper stem sub assembly (21+29).
 - ii. Pull out entire Cartridge Sub-Assembly (5+6+7+8+9+10+11+12+13+14+15+16+17+36) from Body. Follow the below step to dismantle cartridge assembly.
 - iii. Remove Snap Ring (36) and dismantle Disc Nut (9) and Split Ring (10) from Disc (5). Separate Disc Sub-Assembly and 'Stem, Bellows, and Sleeve Holder Weld-Assembly'.
 - III. Follow below steps to dismantle Disc Sub-Assembly.
 - i. Loosen Seat Clamping Screw (8) and Seat Retainer (7).
 - ii. Remove Seat (6) from Disc (5) and replace with New Seat.
 - iii. Reassemble valve in reverse order.

5.0 LUBRICATION

- 5.1 Parts requiring lubrication are Bonnet and Handwheel both threads (20,34), All Bonnet Screw (22) should be lubricated with an anti-seize lubricant to promote ease of future disassembly

6.0 SPECIAL TOOLS AND INSTRUCTIONS

- 6.1 Recommended bolting torques are shown in section “F” of this manual.
- 6.2 Special tool needed to tighten seat retainer.
 - a) Contact CRANE CRYOFLO to purchase seat retainer tool
- 6.3 No special tools are required for general valve maintenance. However, in certain large valve styles, the use of a hydraulic torque device may be necessary to achieve optimum bolt torque.

7.0 PREVENTATIVE MAINTENANCE

- 7.1 Refer to “Section A” of this manual for general valve maintenance information

**CRANE CRYOFLO™ Valves
BELLOWS SEAL Y-GLOBE VALVES**



**Operations and Maintenance Manual
Crane CRYOFLO™**

4526 Research Forest Drive, Suite 400
The Woodlands, TX 77381

Phone: (936) 271-6500
www.cranecryoflo.com

BELLOWS SEAL Y-GLOBE VALVES

1.0 GENERAL INFORMATION

For general information regarding this or any other CRANE CRYOFLO valve please refer to “Section A” of this manual.

2.0 COMPLETE DISASSEMBLY

| | |
|---|--|
|  WARNING | Before disassembling any valve, ensure that all pressure has been removed from the line and from any cavities within the valve. Contact CRANE CRYOFLO valves prior to disassembling any valve. |
|---|--|

2.1 For all details like disassembly, reassembly and spare parts replacement refer to the bellows seal T-Globe Valve detailed in “Section C” of this manual.

2.2 Handwheel Operated Valves

Upon completion of the disassembly procedure listed in “Section C”, the handwheel (30) may be separated from the Bonnet (20), by removing the handwheel nut (31).

2.3 Section C” contains a general disassembly and reassembly procedure. These procedures cover the bulk of the disassembly and reassembly process, however special attention should be paid to the following:

- a) Extreme care should be taken to ensure that the sealing surfaces of the gasket area do not become damaged during disassembly or reassembly. This includes scratches caused by misalignment and/or by debris in the seal area.

2.3.4 CRANE CRYOFLO recommends replacing the Bonnet joint gasket (18), O-Ring (19) and gland seal O-Ring (24, 25) when servicing any valve.

2.3.5 Caution should be exercised in handling the new Bonnet joint gasket (18), O-Ring (19) and gland seal O-Ring (24, 25) to avoid scratching its surfaces.

| | |
|---|--|
|  CAUTION | Caution should be exercised in handling the new Bonnet joint gasket (18), O-Ring (19) and gland seal O-Ring (24, 25) to avoid scratching its surfaces. Scratches in soft seal components may lead to valve leakage after reassembly. |
|---|--|

Y-Globe: Installation, Operation & Maintenance

Section D

| PART IDENTIFICATION | |
|---------------------|------------------------------|
| 1 | BODY |
| 2 | BODY STUB PIPE |
| 3 | TOP PIPE FLANGE |
| 4 | BODY NECK PIPE |
| 5 | DISC |
| 6 | SEAT |
| 7 | SEAT RETAINER |
| 8 | SEAT CLAMPING SCREW |
| 9 | DISC NUT |
| 10 | SPLIT RING |
| 11 | LOWER STEM |
| 12 | PTFE SLEEVE |
| 13 | METAL BELLOW |
| 14 | BELLOW BOTTOM RING |
| 15 | ANTI ROTATION DEVICE |
| 16 | BELLOW TOP RING |
| 17 | SLEEVE HOLDER |
| 18 | SPIRAL WOUND GASKET |
| 19 | O-RING |
| 20 | BONNET |
| 21 | UPPER STEM |
| 22 | SOCKET HEAD CAP SCREW |
| 23 | LOCK WASHER |
| 24 | O-RING |
| 25 | O-RING |
| 26 | GLAND BUSH |
| 27 | HANDWHEEL BUSH |
| 28 | SNAP RING |
| 29 | HANDWHEEL STUD |
| 30 | HANDWHEEL |
| 31 | HANDWHEEL NYLON NUT |
| 32 | WASHER |
| 33 | STRAIGHT FITTING (VENT HOLE) |
| 34 | HANDWHEEL SLEEVE |
| 35 | GRUB SCREW |
| 36 | SNAP RING |

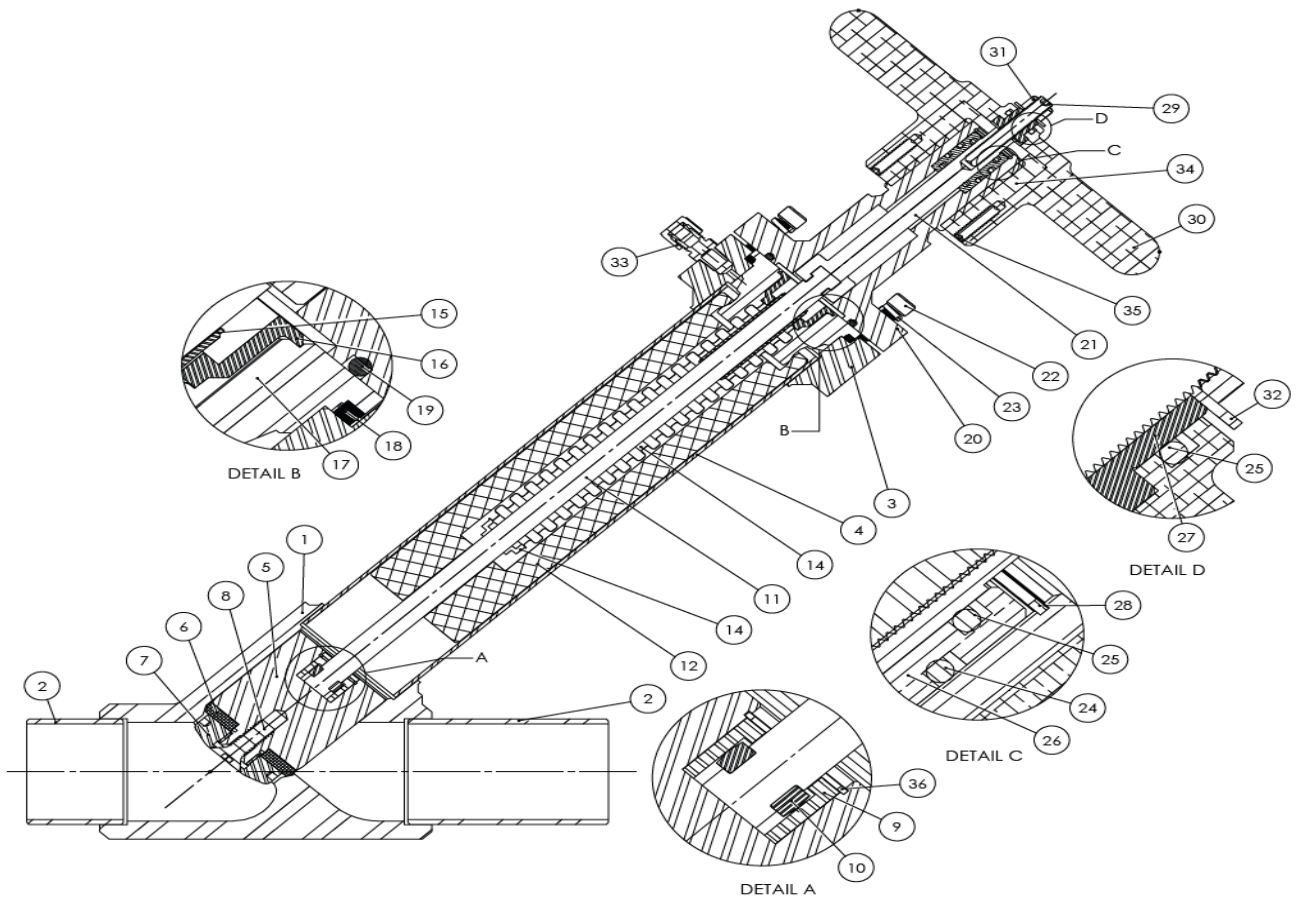

CRANE CRYOFLO™ Valves LIFT CHECK VALVES



Operations and Maintenance Manual Crane CRYOFLO™

4526 Research Forest Drive, Suite 400
The Woodlands, TX 77381

Phone: (936) 271-6500
www.cranecryoflo.com

LIFT CHECK VALVES

1.0 GENERAL INFORMATION

For general information regarding this or any other CRANE CRYOFLO valve please refer to “Section A” of this manual.

2.0 COMPLETE DISASSEMBLY

| | |
|--|--|
|  WARNING | Before disassembling any valve, ensure that all pressure has been removed from the line and from any cavities within the valve. Contact CRANE CRYOFLO valves prior to disassembling any valve. |
|--|--|

2.1 The following page contains a general disassembly and reassembly procedure. These procedures cover the bulk of the disassembly and reassembly process, however special attention should be paid to the following:

- a) Extreme care should be taken to ensure that the sealing surfaces of the gasket area do not become damaged during disassembly or reassembly. This includes scratches caused by misalignment and/or by debris in the seal area.

2.3.6 CRANE CRYOFLO recommends replacing the Cover joint gasket (12) when servicing any valve.

2.3.7 Caution should be exercised in handling the new Bonnet joint gasket (12) to avoid scratching its surfaces.

| | |
|--|--|
|  CAUTION | Caution should be exercised in handling the new Bonnet joint gasket (12) to avoid scratching its surfaces. Scratches in soft seal components may lead to valve leakage after reassembly. |
|--|--|

Lift Check: Part Identification

Section E

| PART IDENTIFICATION | |
|---------------------|-----------------------|
| 1 | BODY |
| 2 | BODY STUB PIPE |
| 3 | TOP PIPE FLANGE |
| 4 | BODY NECK PIPE |
| 5 | C-WASHER |
| 6 | INSULATOR SLEEVE |
| 7 | COVER |
| 8 | DISC |
| 9 | SEAT |
| 10 | STEM |
| 11 | DISC COVER PLATE |
| 12 | SPIRAL WOUND GASKET |
| 13 | SLOTTED SPRING PIN |
| 14 | LOCK WASHER |
| 15 | SOCKET HEAD CAP SCREW |
| 16 | NPT PLUG |

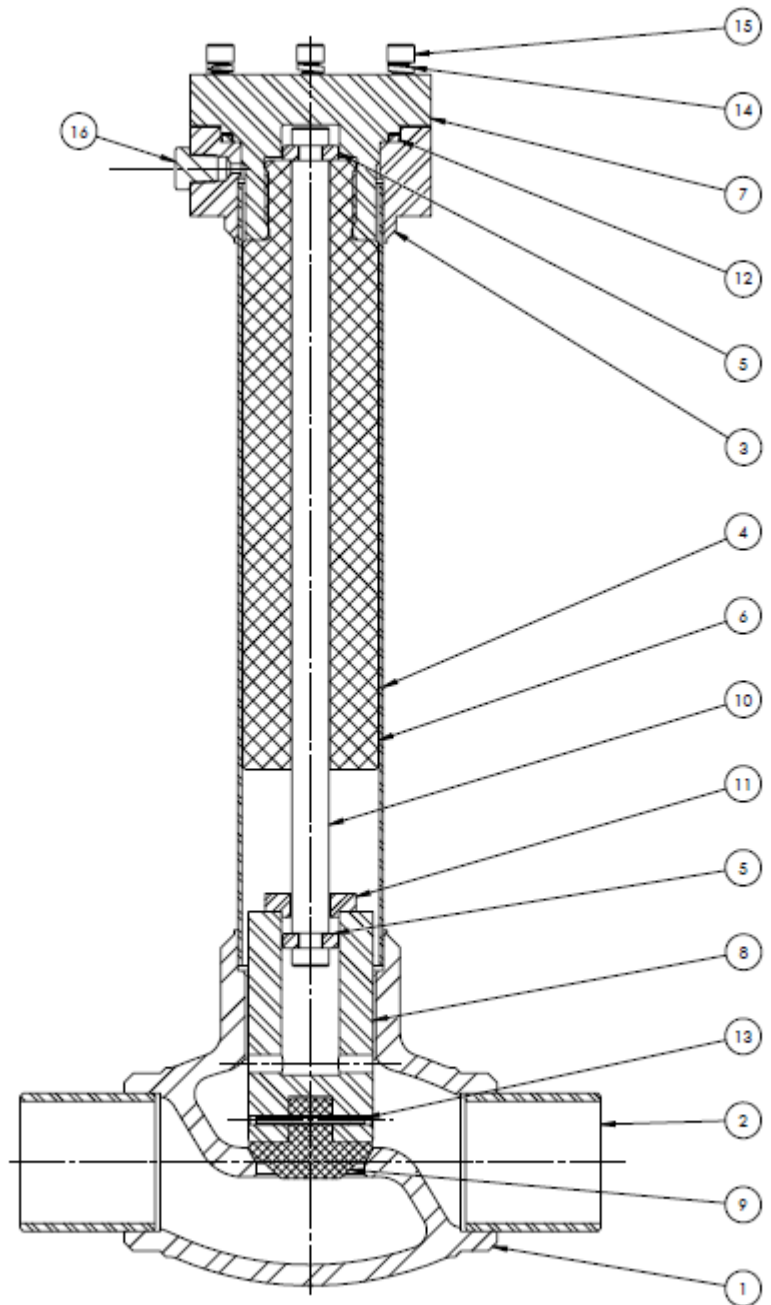

DISASSEMBLY

Before disassembling any valve, ensure that all pressure has been removed from the line and any cavities within the valve. Contact CRANE CRYOFLO valves prior to disassembling any valve.

1. Loosen and remove Socket Head Cap Screw (15) & Lock Washer (14) from assembly.
2. Pull out entire trim assembly (5+6+7+8+9+10+11+13) by lifting Cover (7) upwards. Care should be taken that the trim assembly does not fall back into the body neck while lifting as this may damage the Seat (9) sealing surface.
3. Remove Spiral Wound Gasket (12). Never re-use Spiral Wound Gasket.
4. Loosen the threaded joint between Cover (7) and Insulator sleeve (6) by rotating Cover (7) in the counter-clockwise direction.
5. Hold Disc (8) in a suitable vice and remove the C-Washer(11) above the insulator sleeve (6).
6. Lift the Insulator sleeve (6) upwards until it clears the Stem (10).
7. Remove the tack weld(s) between Disc (8) and Disc Cover Plate (11).
8. Lift the Disc Cover Plate (11) upwards until it clears the Stem (10).
9. Remove Stem (11) and Washer (11) from Disc (8).
10. Turn the subassembly (8+9+13) upside down in vice, with the seat facing the upward direction.
11. Locate the Slotted Spring Pin (13) located between Disc (8) & Seat (9)
12. Remove the Slotted Spring Pin (13) by using a Pin-Removal Punch with a flat end and a smaller diameter than the pinhole diameter in the disc. Using a hammer, strike the punch against the pin. Continue this action until the pin is fully removed.

RE-ASSEMBLY

1. Prior to reassembly clean all parts thoroughly. Clean the gasket seating surface in the Top Pipe Flange (3) and Cover (7) with a fine emery cloth or a heavy-duty shop towel and isopropyl alcohol (70% min).
2. Examine the body seat area for any debris and obvious signs of wear. If there are any signs of wear, contact CRANE CRYOFLO.
3. Replace the Spiral Wound Gasket (12) with a new factory-supplied part and insert into the gasket groove area of the Top Pipe Flange (3).
4. Fasten the threaded joint between Cover (7) & Insulator Sleeve (6) by rotating the cover in a clockwise direction until it bottoms out against Insulator Sleeve (6).
5. Insert spare cartridge assembly (5+6+8+9+10+11+13) in the Top Pipe Flange (3). Care should be taken that trim assembly does not fall into the body and body neck while inserting, as this may damage the Seat (9) sealing surface.
6. Insert the Lock Washer (14) and Socket Head Cap Screw (15) and apply torque as specified in Section F.

Caution should be exercised in handling the new Body-Cover joint gasket (12) and seat (9) to avoid scratching its surfaces. Scratches in soft seal components may lead to valve leakage after reassembly.

MAINTENANCE OF DISASSEMBLED VALVES

For general operation & maintenance information regarding this or any other CRANE CRYOFLO valve please refer to section “A” of this manual.

- 1.1 Following the above-listed disassembly procedures, examine the Body (1) cavity for deposits of foreign material.
- 1.2 Examine seating surfaces in Body (1) and Seat (9) for wear and damage.
- 1.3 If excessive wear or damage is evident, worn parts (or if necessary, the entire valve) should be reconditioned or replaced.
- 1.4 CRANE CRYOFLO offers complete replacement seal kits, cartridge kits, and spare parts for reconditioning or replacement. When ordering, state the figure number (or stock number) of the valve and the body material.
- 1.5 CRANE CRYOFLO offers complete remanufacturing services to rework your valve. If you find this necessary, our nationwide network of Crane Valve Service Centers will remanufacture your valve to factory specifications.

2.0 SPARE PART REPLACEMENT

1. Cartridge Sub-Assembly (5+6+8+9+10+11+12+13)
 - I. Follow the disassembly procedure mentioned in the disassembly section of Section “E”, and replace the cartridge assembly as mentioned in the reassembly section of Lift Check Valve (Section “E”).
2. Gasket Replacement
 - I. Read the warning notice listed in section 2.0 of these instructions.
 - II. Loosen and remove the Socket Head Cap Screw (15) & Lock Washer (14) from the assembly.
 - III. Lift out the entire cartridge assembly (5+6+7+8+9+10+11+13) by lifting Cover(7) upwards. Care should be taken that the cartridge assembly does not fall into the body and body neck while lifting upwards as this may damage the Seat (9) sealing surface.
 - IV. Remove the Spiral Wound Gasket (12)
 - V. Replace the Spiral Wound Gasket (12) with a new factory-supplied part (12).
 - VI. Replace the cartridge assembly (5+6+7+8+9+10+11+13) into the Body (1).
 - VII. Insert Lock Washer (14) and Socket Head Cap Screw (15) and apply torque as specified in Section F.

**CRANE CRYOFLO™ Valves
BOLTING TORQUE VALUES**



**Operations and Maintenance Manual
Crane CRYOFLO™**

4526 Research Forest Drive, Suite 400
The Woodlands, TX 77381

Phone: (936) 271-6500
www.cranecryoflo.com

1.0 GENERAL INFORMATION

For general information regarding this or any other CRANE CRYOFLO valve please refer to “Section A” of this manual. This section details the specific torque values recommended by CRANE CRYOFLO for bolting used in all CRANE CRYOFLO products.

2.0 STANDARD PROCEDURES

- 2.1 Always use new bolting materials
- 2.2 Verify that the materials are compatible with the process system as well as any temperature or pressure requirements. Note that bolting materials can have minor identification changes which may have a substantial impact on performance, i.e.. B8M vs. B8.
- 2.3 Whenever allowed by system and process parameters, use appropriate lubrication to ensure even tightening of the bolting materials.

3.0 TORQUE VALUES

3.1 The bolts shall be tightened evenly using a crisscross pattern by applying torque as per below table.

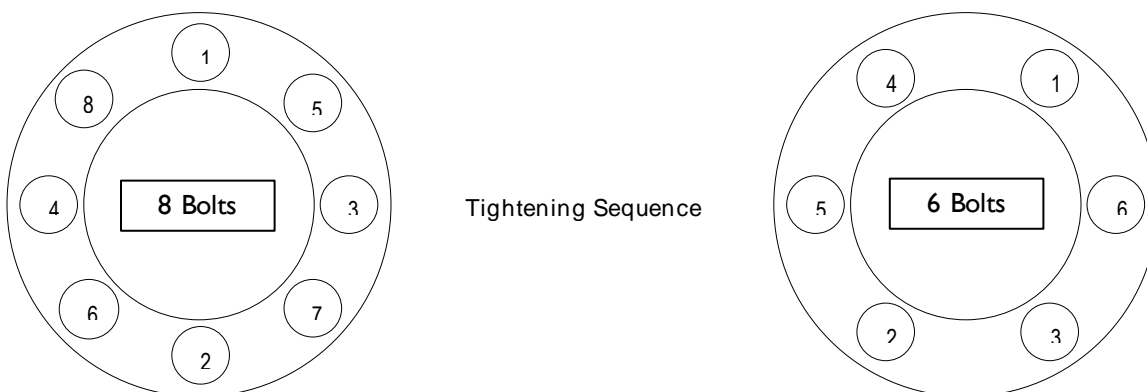

All values are listed in ft.lbs (in.lbs)

| Bolt Dia. | TPI | ASTM SA 320 B8 CL2 BOLTING |
|-----------|-----|----------------------------|
| 1/4 | 28 | 12 (144) |
| 5/16 | 24 | 16 (192) |
| 3/8 | 24 | 27 (324) |
| 1/2 | 20 | 66 (792) |

3.2 Seat Retainer Torque Values, Bellows Seal Globe Valve

3.3

All values are listed in ft.lbs (in.lbs)

| VALVE SIZE | MAWP 300psi |
|------------|-------------|
| 1/2" | 25 (300) |
| 3/4" | 25 (300) |
| 1" | 25 (300) |
| 1 1/2" | 51 (612) |
| 2" | 69 (828) |
| 3" | 107 (1284) |
| 4" | 414 (4968) |
| 6" | 612 (7344) |

CRANE CRYOFLO™ Valves LONG TERM STORAGE



Operations and Maintenance Manual Crane CRYOFLO™

4526 Research Forest Drive, Suite 400
The Woodlands, TX 77381

Phone: (936) 271-6500
www.cranecryoflo.com

1.0 GENERAL INFORMATION

For general information regarding this or any other CRANE CRYOFLO valve please refer to “Section A” of this manual.

2.0 STORAGE

The following recommendations are for preparing valves and their accessories for Long Term Storage. They are necessary to maintain the valves in proper condition prior to installation into the pipeline. By following these procedures, abrasive and corrosive substances can be prevented from affecting valve performance.

It is the purchaser’s responsibility to take the necessary precautions for the protection of valves in storage.

2.1 As-shipped Condition

Valves are packaged with a moisture resistant closure on the valve ends. Where size permits, plastic plugs or caps are used. On larger size valves, wood covers are sealed with tape and securely attached with metal bands. On valves with pipe flanges the wooden covers are secured with bolts. All other openings are covered with plastic caps or plugs.

Parts packaged separately are secured in packaging from the factory to prevent damage during handling and storage. These parts are to be stored off the ground in an area protected from the weather

2.2 Recommended Storage Facilities

The following are a list of storage types in order of most preferred to least preferred:

- Enclosed weather tight building with a concrete floor.
- Enclosed building with a dirt floor. Valves must be on pallets.
- Open air, valves on pallets on a concrete floor covered with a tarpaulin (this is not recommended for more than six months)
- Open air, valves on pallets on a dirt floor and covered with a tarpaulin (this is not recommended for more than six months)

2.3 Inspection

Periodic inspections should be performed on all stored valves and parts. The frequency of these inspections should be determined by the type of storage facilities and weather conditions. At a minimum, all parts and valves should be inspected every 4-6 months. Inspect for dirt, moisture or any other type of contamination. If any is found the valve is to be thoroughly cleaned and dried. Repeat the above listed packaging procedure to ensure the valve is weather tight. Slight external rusting may occur on valves stored outside. This will have little or no effect on their performance. Heavy internal rust, however, may be harmful and must be corrected.

2.4 Preparation for Installation into the Pipeline

Inspect valves as per the above instructions and remove any contamination, assuring that the valve is clean and dry. Re-torque all bolting to factory specifications to compensate for possible bolt relaxation, which may occur during long storage. Ensure that all foreign material has been removed from the valve.

**CRANE CRYOFLO™ Valves
VALVE INSTALLATION**



**Operations and Maintenance Manual
Crane CRYOFLO™**

4526 Research Forest Drive, Suite 400
The Woodlands, TX 77381

Phone: (936) 271-6500
www.cranecryoflo.com

1.0 GENERAL INFORMATION

For general information regarding this or any other CRANE CRYOFLO valve please refer to “Section A” of this manual.

2.0 INTRODUCTION

By exercising proper care in the installation of CRANE CRYOFLO valves, the probability of trouble-free service will be enhanced. It is important to recognize that in the transport, handling and storage of a valve between the time of manufacture and the time of installation, there are numerous possibilities for accident or error, which may affect valve performance.

All valves should be handled/installed in such a manner as to comply with all applicable state, local and federal safety regulations including, but not limited to OSHA regulations. Personal Protective Equipment (PPE) should also be used in compliance with all regulations.

3.0 INSPECTION AND HANDLING

Before installation of the valve, it is important to determine that the valve is in satisfactory condition. It may be helpful to observe the following points, in order to avoid subsequent valve problems:

- 3.1 Carefully unpack valve and note any special warning tags or identification plates attached to the valve; take appropriate action.
- 3.2 Check valve for any markings indicating flow direction. If flow direction is indicated, appropriate care should be exercised to install the valve in the proper flow orientation. Globe Valves & Globe type Check valves are uni-directional and must be installed in the proper orientation.
- 3.3 Inspect the valve interior through the end ports to determine that it is clean and free from foreign matter and/or harmful corrosion. Remove any special packing materials (blocks to prevent disc movement) or packages of desiccant. The discs of weld end globe valves should be slightly open during welding of the valves into the pipeline.
- 3.4 Check the pipeline to ensure that it is properly aligned and supported. Expansion joints or bends should be installed in the pipeline to compensate for expansion and contraction.
- 3.5 Only qualified riggers should handle the valves. The lifting point for all CRANE CRYOFLO valves is by the use of a strap or chain around the neck area of the valve body. Do not lift CRANE CRYOFLO valves by use of straps or chains on or around the handwheel or other interior connections. After the weight of the valve is supported by a strap or chain around the neck of the valve body, other lines may be attached for steadying the valve in place during installation.
- 3.6 Immediately prior to valve installation the interior of the piping (to which the valve is to be attached) should be checked for cleanliness and freedom from foreign materials.

4.0 INSTALLATION

| | |
|--|--|
|  CAUTION | All valves should be installed in such a manner as to prevent exposure to excessive vibration and process flow turbulence. Check valves specifically are subject to increased turbulence and wear due to their position in a piping system. At a minimum, check valves should have 10 pipe diameters of straight pipe immediately upstream of the valve. |
|--|--|

When CRANE CRYOFLO valves with bevel gear, motor or air cylinder operators are mounted in a position other than with the valve stem in a vertical position, contact CRANE CRYOFLO for specific instructions

Welded joints when properly made, provide a structural and metallurgical continuity between the pipe and the valve body. For socket weld joints it is usually required that the weld fillet have more cross-sectional area than the pipe. Butt welds usually require full penetration and thickness at least equal to that of the pipe. If a pipe of a high strength alloy is welded to a valve with body material of lower mechanical strength, the weld usually must taper to a compensating greater thickness at the valve end, or the valve must have a matching high strength welded-on extension or "pup".

| | |
|---|--|
|  CAUTION | <p>All welding should be in accordance with any Code or jurisdictional regulations applicable to the piping system construction and with complete and approved welding procedures and inspected as required by applicable specification.</p> |
|---|--|

The following items are a general overview of sound welding practice:

- 4.1.1 Check material markings on pipe and valve to confirm they are as specified.
- 4.1.2 Inspect welding end surfaces, dimensions, and cleanliness. Correct any condition that might interfere with assembly and satisfactory welding.
- 4.1.3 If backing rings are to be used, check to confirm that ring material is compatible with pipe and valve materials, check individual rings for fit and cleanliness.
- 4.1.4 Determine that the prescribed welding parameters including preheating and post weld heat treating if required, are in accordance with the approved welding procedure.
- 4.1.5 Inspect valve-pipe end alignment; adjust if and as required.
- 4.1.6 Securely tack weld.
- 4.1.7 Complete weld, using approved welding procedure.

| | |
|---|--|
|  CAUTION | <p>Torque wrenches should be used for flange bolting. If, in the tightening process, the torque on a given bolt has been increasing with each part turn, and then is observed to remain unchanged or increase a much lesser amount with an additional part turn, that bolt is yielding. Such bolt should be replaced and scrapped.</p> |
|---|--|

5.0 TESTING AND ADJUSTMENT

- 5.1 When a valve has been properly inspected and installed, it is reasonable to assume it will be in good condition and ready to operate. Nevertheless, it is at this time that the valve is at the end point of its more vulnerable phase. Operability can be proven only by test.
- 5.2 A first observation can be made by actuating the valve through an open-close, or close-open cycle. If no obvious problems are observed, an actual test at pressure may be applied while tightness and operability are checked.
- 5.3 It is common practice after the installation of piping systems to clean the systems by blowing with gas or flushing with a liquid to remove debris and/or internal protective films and coatings. It should be recognized that valve cavities may form a natural trap in a piping system and material not dissolved in or carried out by the flushing fluid may settle in such cavities and adversely affect valve operation. Also, abrasive material carried by a high velocity fluid stream may cause serious damage to seating surfaces. Again, great care should be taken to ensure that the valve is free of all debris prior to operation.
- 5.4 Upon installation, new valve lubrication should be applied to all lubrication points.

**CRANE CRYOFLO™ Valves
GASKET MAINTENANCE AND VALVE LUBRICATION**

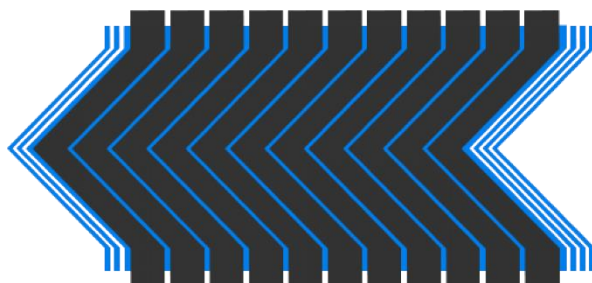

**Operations and Maintenance Manual
Crane CRYOFLO™**

4526 Research Forest Drive, Suite 400
The Woodlands, TX 77381

Phone: (936) 271-6500
www.cranecryoflo.com

Gasket Maintenance and Valve Lubrication

Section I

For general information regarding this or any other CRANE CRYOFLO valve please refer to "Section A" of this manual.

2.0 GASKET MAINTENANCE

Note: The following information refers primarily to valves that have been repaired/reconditioned previously. It is always a sound practice to inspect and maintain all sealing areas. Spiral wound gaskets should be treated as single-use items and must be replaced after any disassembly, or when they start to leak show signs of wear or damage.

Inspection of the valve body/bonnet joint should be a part of routine maintenance inspection after installation and start-up. In addition to improper gasket installation procedure, thermal changes, pressure changes, vibrations etc. also may cause leakage. If re-torquing of the bolting does not stop the leakage, the flanged joint should be unbolted, and the gasket carefully examined

| OBSERVATION | POSSIBLE REMEDIES |
|---|--|
| Gasket unevenly compressed around circumference | Improper bolt-up procedure followed. Make certain proper sequential bolt-up procedures are followed. |

3.0 GASKET INSTALLATION PROCEDURES

Regardless of the type of gasket being used or the materials of construction, certain basic procedures must be followed during assembly to ensure proper operation.

While these comments may seem elementary, they are extremely important in achieving a satisfactory seal and minimizing the time required to successfully make up joints. The procedures should be followed whether bolt stresses will be achieved with ordinary stud wrenches, preheating studs, using tensioning devices, using torque wrenches, or using hydraulic wrenches.

- 3.1 Inspect the gasket seating surfaces. Look for tool marks, cracks, scratches or pitting by corrosion and make sure that the gasket seating surface is proper for the type of gasket being used. Radial tool marks on a gasket seating surface are virtually impossible to seal regardless of the type of gasket being used, therefore every attempt must be made to minimize them.
- 3.2 Inspect the gasket. Make sure the material is as specified, look for any possible defects or damage in the gasket.
- 3.3 Inspect and clean each stud or bolt, each nut, each washer, and the facing on the flanges against which the nuts will rotate. Look for severe galling, pitting, etc. If any of the above-mentioned items are damaged beyond repair, replace the damaged item.
- 3.4 Lubricate all thread contact areas and nut facings. The importance of proper lubrication cannot be over-stressed. No joint should be made up without the proper lubricant being applied to the threaded surfaces and to the nut facings.
- 3.5 If the gasket is being installed in a recess or a groove, center the gasket midway into the recess or the groove.
- 3.6 Torque the bolts up to thirty percent (30%) of the final torque value required following the sequence recommended. With any gasket material, it is extremely important to follow a proper bolting sequence. If this sequence is not followed, the flanges can be cocked. Then, regardless of the amount of subsequent torquing, they cannot be brought back parallel.
- 3.7 Repeat step 3.6, increasing the torque to approximately 50 to 60 percent of the final torque required.
- 3.8 Continue with a star pattern of retorquing all studs or bolts to the desired amount until no further rotation of the nuts can be achieved. This may require several retorquing since as one stud is torqued it will relieve the stress on the adjacent stud until such time as equilibrium is achieved.