

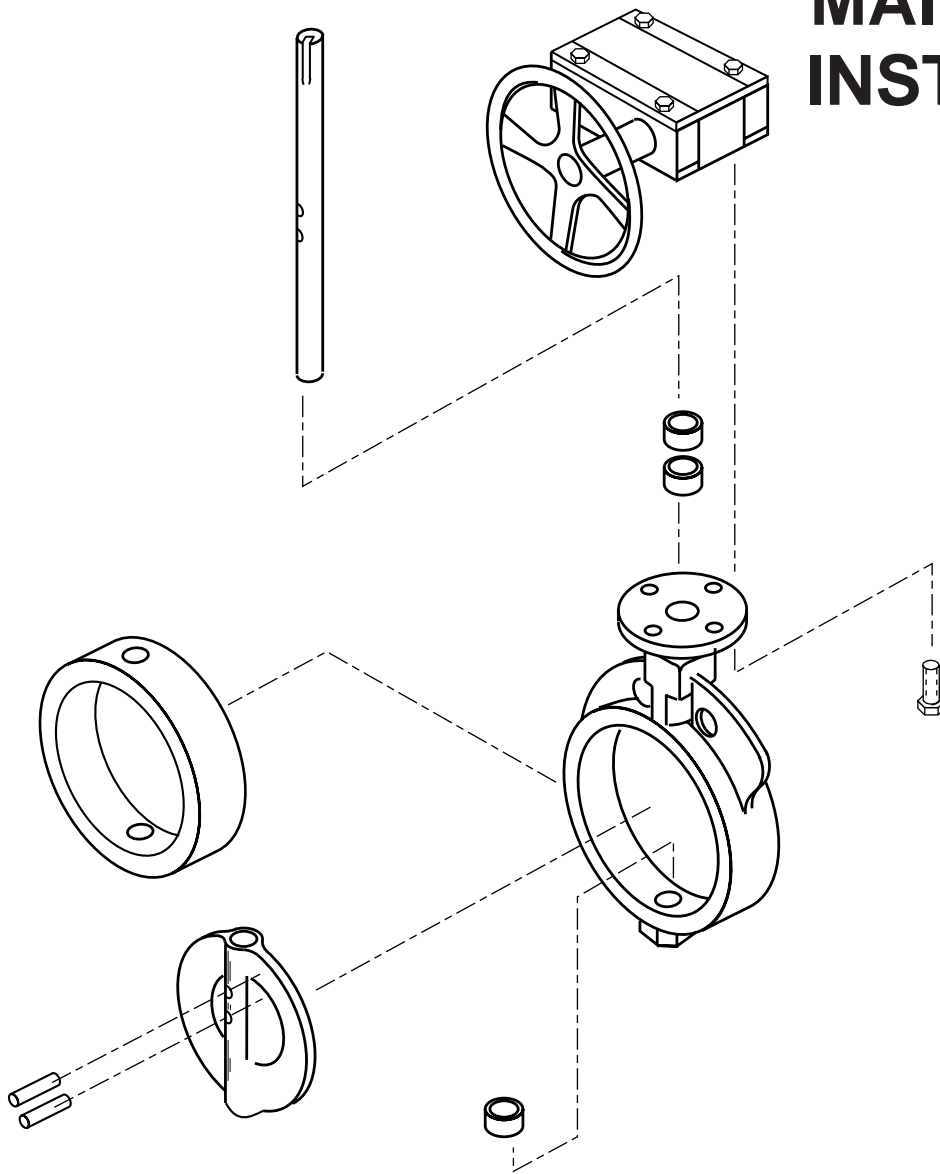

# INSTALLATION and MAINTENANCE INSTRUCTIONS



MANUAL AND AUTOMATED

RESILIENT SEAT BUTTERFLY VALVES

# CONTENTS

---

## Introduction

Valve Description .....	3
Valve Design Features .....	3
Flange and Pipe Schedule Compatibility .....	3
Gasket Compatibility .....	3
Operating Pressures .....	3
Product Identification .....	3

## Installation Recommendations

Valve Ratings .....	4
Valve Seat Position .....	4
Disc Clearances .....	4
Opening Rotation .....	4
Installation Position .....	4
Valve and Flange Preparation .....	4
Installation Tools .....	4
Required Bolting .....	4
Unpacking and Storage Instructions .....	4
Pre-Installation Procedure .....	5
Valve Installation Procedure .....	5 & 6
Flange Bolting Recommendations .....	7

## Maintenance Instructions

Safety Precautions .....	8
General Maintenance .....	8
Butterfly Valve Disassembly .....	8
Butterfly Valve Assembly .....	8 & 9
Ratchet Handle Mounting Procedure.....	10
Manual Gear Mounting Procedure.....	10
Remote Actuator (Male Drive) Mounting Procedure.....	10
Remote Actuator (Female Drive) Mounting Procedure.....	10
Parts List.....	11
Stockham Figure Number System.....	Back Cover

# INTRODUCTION

## SECTION 1

### Valve Description

The Stockham Resilient Seat Butterfly Valve (RSBFV) is designed for use in ASME Class 150 piping systems and is available in both Wafer and Lug style body designs. The standard valve size range available is as follows:

- 200 psi Standard BFV                      2" to 12"
- 150 psi Standard BFV                      14" to 36"
- 285 psi BFV                                    2" to 24"

Stockham 285 Butterfly Valve is also available with an ASME Class 300 bolt pattern for Lug bodies of sizes 2" through 12".

### Valve Design Features

- The unique Stockham seat and disc design insures positive valve sealing while maintaining low seating torque.
- All Stockham Butterfly Valve discs are precision machined to a half ball profile, providing a precise disc to seat relationship.
- Stockham's cartridge style seat incorporates an elastomer bonded to a phenolic stabilizing ring, eliminating elastomer movement and reducing seat tearing or fatiguing due to bunching.
- Stockham's basic three bushing design completely isolates the valve shaft from the body, resulting in increased control of the valve disc, lower valve seating torque, and longer valve life.
- The Stockham cartridge seat has a much smaller mass of elastomer than traditional boot seat designs, limiting seat swell and the accompanying variations in seating torque.

### Flange and Pipe Schedule Compatibility

The Stockham RSBFV is designed to fit between standard piping flanges as follows:

- ASME 125 Cast Iron Flanges (All Sizes)
- ASME 150 Steel Flanges, Schedule 40 (All Sizes)
- ASME 150 Steel Flanges, Schedule 80 (2" to 10")
- ASME 300 Steel Flanges, Schedule 40 (285 Lug, 2" to 12" only).

When using Schedule 80 piping, special care must be taken to make sure the valve is centered between the flanges to prevent damage to the disc edge when opening or closing.

### Gasket Compatibility

In the Stockham butterfly valve design, the elastomer seat extends beyond the valve face and provides a leakproof seal between the valve and the mating pipe flange faces. Gaskets are not needed and should not be used when the valve is installed between standard weld neck or slip-on type flanges.

### Operating Pressures

All Stockham 200 Butterfly Valves are rated at 200 psi bubble tight shut-off for sizes 2" to 12" and 150 psi bubble tight shut-off for sizes 14" and larger. Stockham 285 Butterfly Valves are rated for bubble tight shutoff at 285 psi.

### Product Identification

Each Stockham valve has an identification tag attached to the valve body. Information on this tag includes the valve Series Number, materials of construction for the Body, Disc, and Seat, and the valve Pressure Rating.



SERIES \_\_\_\_\_  
BODY \_\_\_\_\_  
DISC \_\_\_\_\_  
SEAT \_\_\_\_\_  
RATING \_\_\_\_\_ PSI

# INSTALLATION RECOMMENDATIONS

## SECTION 2

### Valve Ratings

Stockham valves are intended for use at the pressure indicated on the nameplate attached to each individual valve. Check the valve operating temperature and pressure rating before proceeding with installation.

### Valve Seat Position

All Stockham butterfly valves are completely bi-directional, so installation is not dependent on seat orientation. Bubble-tight shutoff will be achieved in this orientation with 25 to 150 psi  $\Delta P$  across the valve.

### Disc Clearances

Prior to installing the valve, it is important to make sure the ID of the pipe and the pipe flanges are large enough to allow the disc edge to swing into the opening without interference. Damage to the disc edge can severely affect the performance of the valve. Flange and pipe schedule compatibility for Stockham valves is shown in Section 1 of this manual.

### Opening Rotation

The Stockham valve disc can rotate 360° without damaging the valve or elastomer seat. The valve is designed to open with either clockwise or counterclockwise rotation of the shaft.

### Installation Position

To prevent damage to the disc and seat during installation, the valve disc should be slightly open but not extending beyond the valve liner face. Positioning the disc in this “almost closed” position will reduce seat interference and initial torque build-up during valve installation.

In general, it is preferable to install RSBFV's with the shaft in a horizontal orientation. In this position, shaft and disc weights are evenly distributed, minimizing seat wear. Additionally, any foreign matter which may accumulate at the bottom of the disc and shaft is effectively removed each time the valve is opened.

Stockham butterfly valves are designed to operate between two flanges. If the valve installation calls for the use of one pipe flange only, a Lug style valve with Dead End Service feature must be used.

### Valve and Flange Preparation

If the valve and mating pipe are properly prepared for installation, future problems can be avoided. All valve seat and pipe flange faces should be free of dirt, grit, dents, or surface irregularities which may disrupt flange sealing and cause external leakage. The valve disc sealing surface should also be inspected to eliminate any dirt or foreign material that will adversely affect the operation of the valve.

### Installation Tools

The only tool required in the installation of a Stockham RSBFV is a wrench suitable for tightening the flange bolts and/or nuts required to secure the valve in-line. A hoist may be required to help manipulate valves 10" and larger. Smaller sized valves can usually be installed by hand. Temporary pipe supports may be used to keep mating flange faces parallel in order to aid in valve installation.

### Required Bolting

The table outlined on Page 7 is furnished to provide information regarding the size, type, and quantity of bolting recommended for the installation of Stockham RSBFV's. This table is intended for use as a planning and procurement guide. All recommendations are based on pipe flanges in accordance with ASME125/150 specifications. Flange bolting is not included with the valve shipment.

### Unpacking and Storage Instructions

1. Check the packing list against the valve received to verify that the size, material, and trim are correct.
2. Check to make sure that the valve and operator were not damaged during shipment.
3. When lifting the valve, take care to avoid damage to the flange faces, disc sealing edge, or operator.
4. If the valve is to be stored before being installed, it should be protected from harsh environmental conditions.
5. Store the valve with the disc in the “almost closed” position to protect the sealing edge and the seat.
6. Keep the valve in a clean location, away from dirt, debris and corrosive materials.
7. Keep the valve in a dry area with the flanges protected and on a suitable skid or pallet.
8. Keep the valve in a cool location if possible, out of direct sunlight.

# INSTALLATION RECOMMENDATIONS

## Pre-Installation Procedure

1. Remove any protective flange covers from the valve.
2. Inspect the valve to be certain the waterway is free from dirt and foreign matter. Be certain the adjoining pipeline is free from any foreign material such as rust and pipe scale or welding slag that could damage the seat and disc sealing surfaces.
3. Any actuator should be mounted on the valve prior to installation to facilitate proper alignment of the disc in the valve seat.
4. Check the valve identification tag for materials, and operating pressure to be sure they are correct for the application.

**WARNING!** *Personal injury or property damage may result if the valve is installed where service conditions could exceed the valve ratings.*

5. Check the flange bolts or studs for proper size, threading, and length.

## Valve Installation Procedure

Position the connecting pipe flanges in the line to insure proper alignment prior to valve installation. Spread the pipe flanges apart enough to allow the valve body to be located between the flanges without actually contacting the flange surfaces (See Figure 1.) Exercise particular care in handling the valve so as to prevent possible damage to the disc or seat faces.

1. For Wafer style valves:
  - a. Place the valve between the flanges.
  - b. Loosely install the two upper and lower flange bolts that pass through the body alignment holes.
  - c. Install the remaining flange bolts, shifting the valve as necessary to permit the bolts to pass by the valve body. Hand tighten all bolts as necessary.

### For Lug style valves:

- a. Place the valve between the flanges.
  - b. Install all bolts between the valve and the mating flanges. Hand tighten bolts as necessary.
2. Before completing the tightening of any bolts, the valve should be centered between the flanges and then carefully opened and closed to insure free, unobstructed disc movement (See Figure 2.)
  3. Using the sequence shown in Figure 3, tighten the flange bolts evenly to assure uniform compression.
  4. If an actuator is to be used, air hoses or electricity should be connected to the unit as specified by the actuator manufacturer.
  5. Cycle the valve to the fully open position, then back to the fully closed position, checking the actuator travel stop settings for proper disc alignment. The valve should be operated to assure that no binding is taking place.
  6. The valve is now ready for operation.

**Remember:** *Install the valve with the disc in the "ALMOST CLOSED" position. Do not use any flange gaskets.*

### Figure 1-Initial Installation of Valve

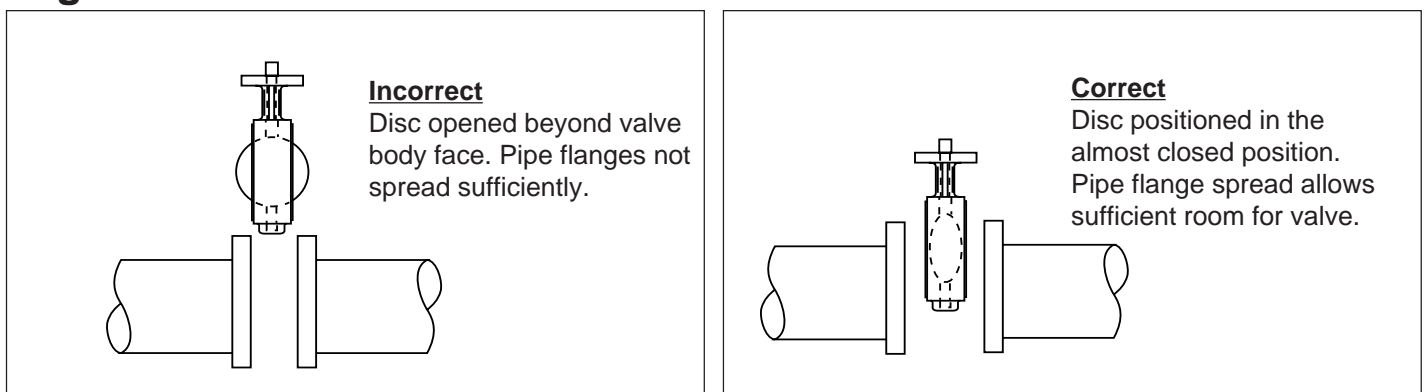

# INSTALLATION RECOMMENDATIONS

## Figure 2-Centering and Flanging of Valve

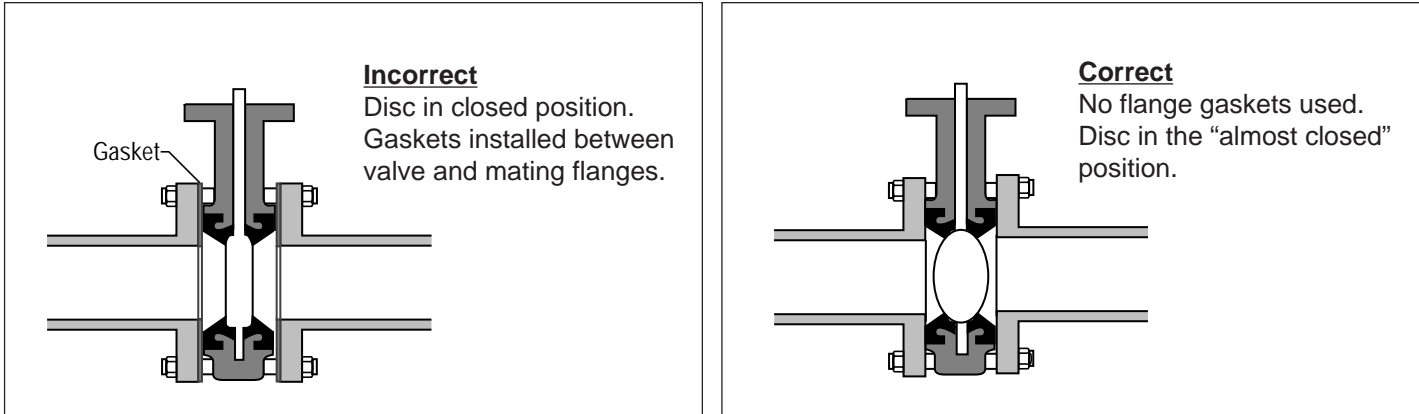

## Figure 3-Flange Bolt Tightening Sequence

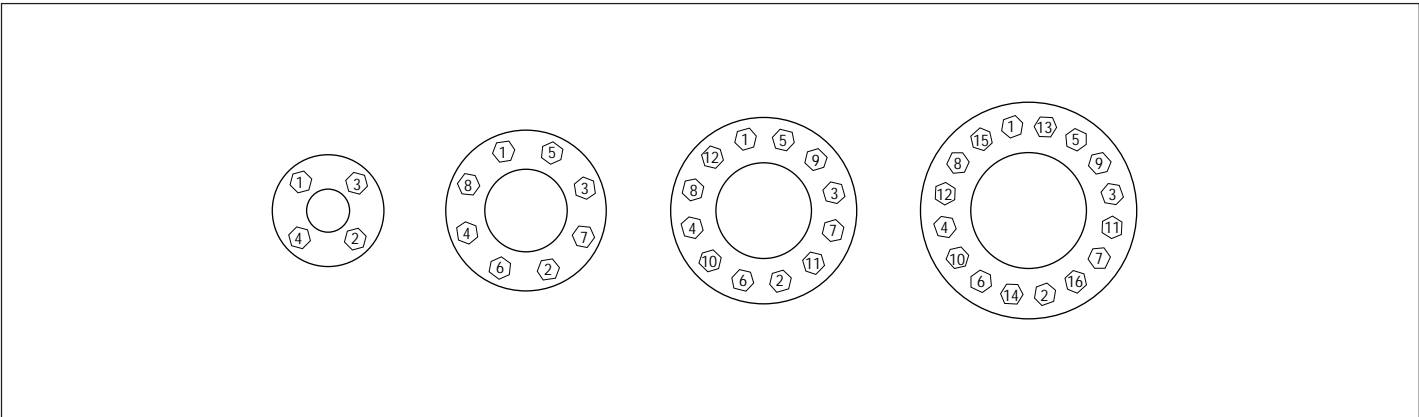

## Figure 4-Final Valve Alignment and Tightening of Flange Bolts

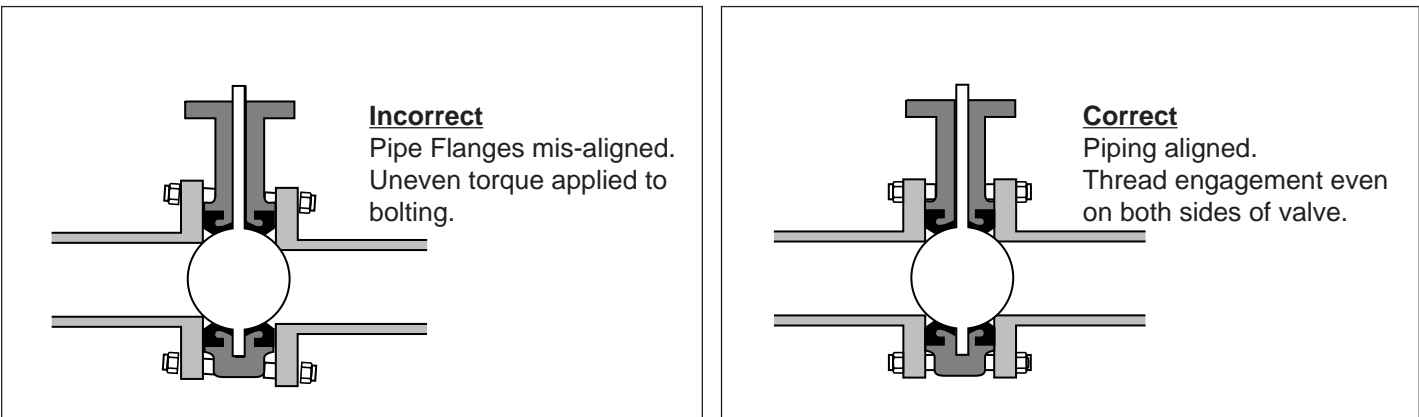

# INSTALLATION RECOMMENDATIONS

## Flange Bolting Recommendations

### Stockham Wafer And Lug Valves, 2"-30", ASME 125/150 Bolt Pattern

Valve Size	Thread Size	Number Required	Stud Length Wafer B'fly (in.)	Bolt Length Lug B'fly (in.)	Req. Torque (Ft-lbs)
2"	5/8-11	4	4.750	1.250	15-60
2 1/2"	5/8-11	4	5.250	1.500	15-60
3"	5/8-11	4	5.250	1.500	15-60
4"	5/8-11	8	5.750	1.750	15-60
5"	3/4-10	8	6.000	1.750	25-100
6"	3/4-10	8	6.250	2.000	25-100
8"	3/4-10	8	6.750	2.250	25-100
10"	7/8-9	12	7.250	2.250	50-200
12"	7/8-9	12	7.750	2.500	50-200
14"	1-8	12	8.250	2.750	70-300
16"	1-8	16	8.750	2.750	70-300
18"	1 1/8-7	16	10.000	3.500	100-400
20" 200	1 1/8-7	20	11.250	4.250	100-400
20" 285	1 1/8-7	16 + 4 ea.	11.250 5.000	4.250 3.250	100-400 100-400
24" 200	1 1/4-7	20	12.750	4.750	150-500
24" 285	1 1/4-7	16 +4 ea.	12.750 5.250	4.750 3.750	150-500 150-500
30" 200	1 1/4-7	24 +4 ea.	13.750 5.750	4.500 4.250	150-500 150-500

Bolting and torque recommendations are made without a warranty, and apply only to steel weld-neck or slip-on flanges. The use of lock washers and/or lubrication with the bolting will affect stated torque values.

# MAINTENANCE INSTRUCTIONS

## SECTION 3

### Safety Precautions

Before removing the valve from the line or loosening any bolts, it is important to verify the following conditions:

1. Be sure the line is depressurized and drained.
2. Be sure of the pipeline media. Proper care should be taken for protection against toxic and/or flammable fluids.
3. Never remove the valve without an Operator (Manual or Automatic) already attached to the valve shaft.
4. Never remove the Operator from the valve while the valve is in the pipeline under pressure.
5. Always be sure that the disc is in the closed position before removing the valve.

### General Maintenance

The following periodic preventative maintenance practices are recommended for all Stockham Butterfly Valves.

1. Operate the valve from full open to full closed to assure operability.
2. Check flange bolting for evidence of loosening and correct as needed.
3. Inspect the valve and surrounding area for previous or existing leakage at flange faces or shaft connections.
4. Check piping and/or wiring to actuators and related equipment for looseness and correct as needed.

### Butterfly Valve Disassembly

1. Position valve flat with the disc in the closed position.
2. Loosen the taper pin(s) from the valve disc using a hammer and punch.  
Note: Punch should be of same size or larger diameter as small end of taper pin to avoid mushrooming of taper pin.
3. Remove taper pin(s) from disc. Extract the valve shaft from the body using a twisting motion.
4. Remove the valve disc from body making sure not to damage the seat or disc sealing edge.
5. Cartridge seat removal can be accomplished from either direction by applying pressure evenly on one face to push the seat through the body. If the valve is of dead end service design, remove set screws around periphery of body extending into seat prior to seat removal.
6. Remove shaft bushings from body as required.

### Butterfly Valve Assembly

1. Thoroughly clean all parts. Inspect components for any defects.
2. Apply a small amount of silicone grease to the inside surfaces of the body, including the upper and lower shaft holes.
3. Insert the shaft bushings into the body being careful not to allow intrusion into the body seat bore.
4. Install the seat into the center of the body, making sure the shaft holes in the seat line up with the holes in the body.

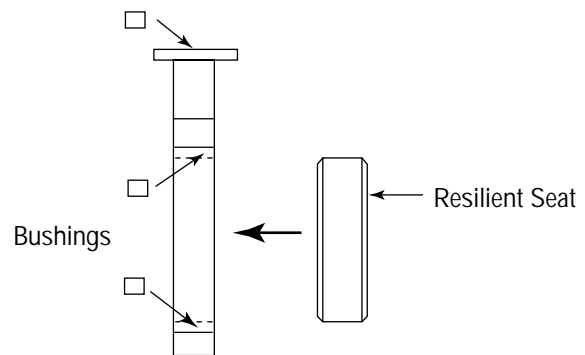

5. Completely coat the inside surfaces of the seat with silicone grease. Carefully push the disc into the seat in the open position (90 degrees to the body.) Line up the shaft holes of the disc as close as possible with the shaft holes in the seat body.

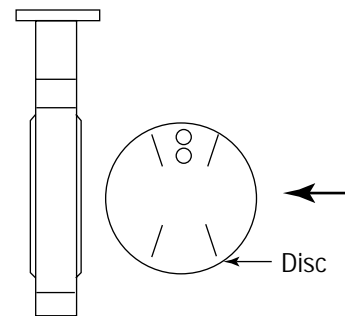



# MAINTENANCE INSTRUCTIONS

---

## Butterfly Valve Assembly (continued from page 8)

6. Insert the shaft through the body and disc, use a twisting motion to align the keyway parallel with the disc.

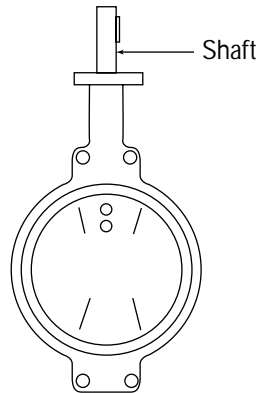

7. Insert taper pin(s) into the disc and set with two or three sharp blows. Wipe dust shield o-ring with silicone grease and place over the shaft into the top of the body.
8. If the valve is of dead end service design, insert set screws through the body into the seat.

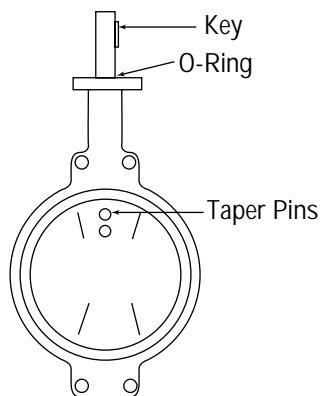

# MAINTENANCE INSTRUCTIONS

---

## Ratchet Handle Mounting Procedure

1. Position the disc in the closed position.
2. Install the ratchet plate using machine bolts, nuts and lock washers, but do not tighten the fasteners.
3. Install the drive key in the shaft. Tap the key into place to ensure it is fully seated in the keyway.
4. Install the handle so that it is parallel with the disc face. The locking lever must be fully retracted before it will pass through the ratchet plate. Tighten the set screw in the handle against the key.
5. With the handle installed flush with the ratchet plate, engage the locking lever with the ratchet plate. Using the handle, adjust the position of the ratchet plate until the disc face is parallel with the valve face, then tighten the fasteners securely.

## Manual Gear Mounting Procedure

1. Position the disc in the closed position.
2. Install the drive key in the shaft. Tap the key into place to ensure it is fully seated.
3. Rotate the gear shaft to the full clockwise position. Align the keyway in the gearbox bore with the key in the shaft and slide the gearbox onto the shaft.
4. Fasten the gearbox to the mounting bracket with the appropriate machine bolts and lock washers. It may be necessary to rotate the gear shaft slightly to align the mounting holes in the gear with the plate.
5. Adjust the stops in the gearbox to position the face of the disc parallel with the face of the valve in the closed position and perpendicular to the face of the valve in the open position.

## Remote Actuator (Male Drive) Mounting Procedure

1. Position the disc in the closed position.
2. Install the actuator mounting bracket on the valve body with the actuator mounting holes facing up-ward. Fasten the bracket securely in place with the appropriate machine bolts, nuts, and lock washers.
3. Install the drive key in the keyway of the shaft. Tap the key in place to insure it is fully seated.
4. Install the drive coupling on the shaft by lining up the proper keyway in the coupling with the key in the shaft.
5. Rotate the actuator shaft to the full clockwise position. Align the drive coupling with the actuator shaft and install the actuator on the mounting bracket.
6. Fasten the actuator to the mounting bracket with the appropriate machine bolts and lock washers. It may be necessary to slightly rotate the actuator shaft to align the mounting holes in the actuator with the mounting bracket.
7. Adjust the stops in the actuator to position the face of the disc parallel with the face of the valve body in the closed position and perpendicular to the face of the valve body in the open position.

## Remote Actuator (Female Drive) Mounting Procedure

1. Position the disc in the closed position.
2. Install the actuator mounting bracket on the valve body with the actuator mounting holes facing up. Fasten the bracket securely in place with the appropriate machine bolts, nuts, and lock washers.
3. Install the drive key in the shaft. Tap the key in place to insure it is fully seated.
4. Install the drive coupling on the shaft by lining up the proper coupling keyway with the key in the shaft.
5. Install the drive key in the drive coupling. Tap the key in place to insure it is properly seated.
6. Rotate the actuator to the full clockwise position. Align the keyway in the actuator bore with the key in the drive coupling and slide the actuator on the drive coupling.
7. Fasten the actuator to the mounting bracket with the appropriate machine bolts and lock washers. It may be necessary to rotate the actuator slightly to align the actuator with the mounting bracket.
8. Adjust the stops in the actuator to position the face of the disc parallel with the face of the valve body in the closed position and perpendicular to the face of the valve body in the open position.

# MAINTENANCE INSTRUCTIONS

---

## Parts List

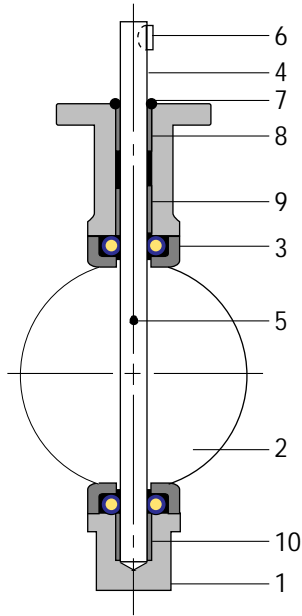

### 200 and 285 Butterfly Valves

Item	Description
1	Body
2	Disc
3*	Seat
4	Shaft
5*	Taper Pin
6	Key
7*	O-Ring
8	Bushing
9	Bushing
10	Bushing

\* Recommended Spare Parts

## Ordering Information

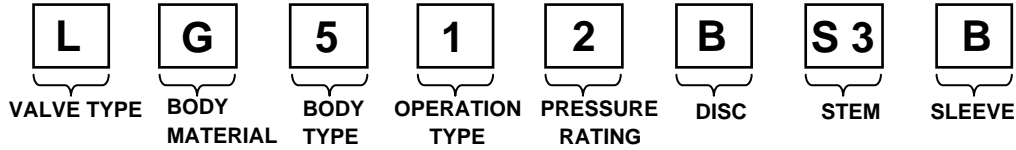

VALVE TYPE	CODE
Butterfly	L

BODY MATERIAL	CODE
Cast Iron	G
Ductile	D

BODY TYPE	CODE
Wafer	5
Lug, Drilled & Tapped	7

OPERATION TYPE	CODE
Bare Stem	0
Lever	1
Gear	2
Air Actuator	3
Electric Actuator	4
Lever with Memory Stop	5
Gear with Memory Stop	7
Gear with Chainwheel	8

PRESSURE RATING	CODE
150	1
200	2
285 <sup>†</sup>	3

DISC	CODE
Aluminum Bronze	B
Ductile Iron* Nickel Plated	D
Type 316 Stainless Steel	S

STEM	CODE
Type 316 Stainless Steel 1-pc	S2
Type 416 Stainless Steel 1-pc	S3

SLEEVE	CODE
Abrasion Resistant Buna-N	AB
Buna-N	B
Hypalon	H
EPT (EPDM)	E
Viton**	V
+/- FDA APPROVED	
EPT	FE
Buna-N	FB

\* Ductile disc is not recommended for water service.  
 \*\* Please consult our factory for information concerning material recommendation for Viton.  
 +/- Inquiries or orders must specify FDA requirements  
<sup>†</sup> 285 CWP Products are available on request. Please contact Customer Service