

ELRO[®]

BA-GP-GB/04.23

Pumps for hazardous materials GUP 3-1,5 and GP 20/10 Ex

Operating Manual and
Installation Instructions
Installation, Operation
and Maintenance

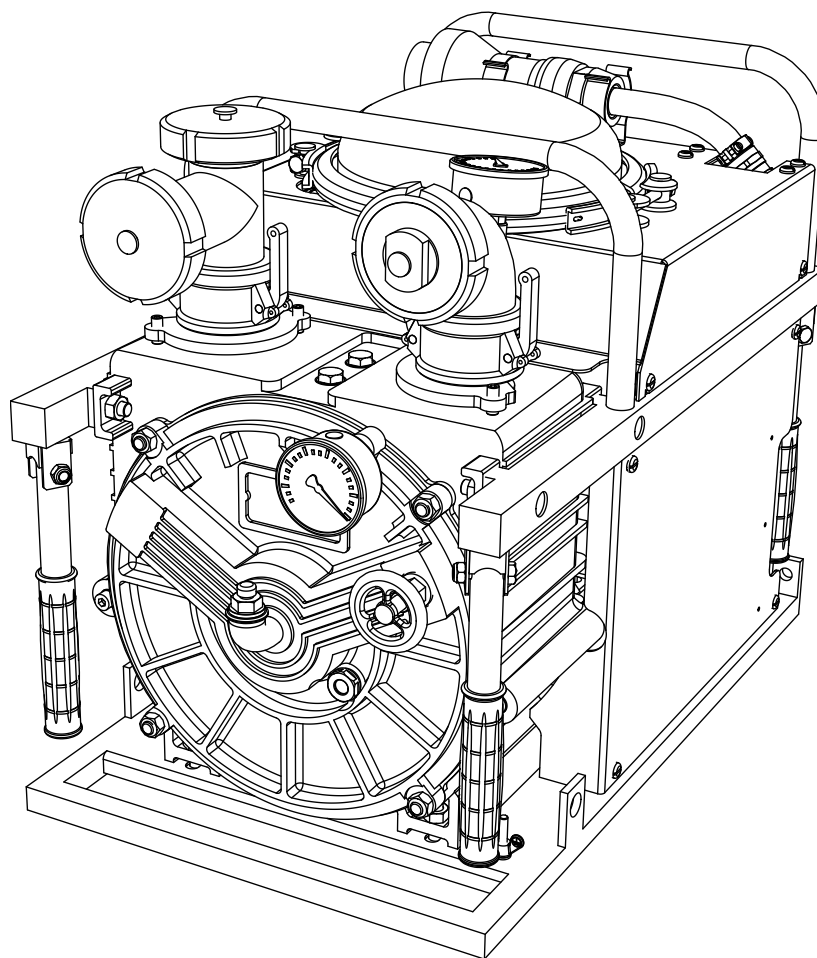

CRANE[®]

www.cranechempharma.com



EC-Declaration of Conformity

In compliance with the Machine Directive 2006/42/EC

We hereby declare, that the pump units manufactured in series production

Designation: ELRO Peristaltic Pump

Series: GUP 3-1,5 and GP 20/10Ex

Manufacturer: Crane Process Flow Technologies GmbH
Heerdter Lohweg 63-71
40549 Düsseldorf
www.elropumps.com

Serial number: see name plate

in the version delivered by us, is in compliance with the following applicable regulations:

EC-Directive: Machinery Directive 2006/42/EC
EMC Directive 2014/30/EU

Harmonized Standards: DIN EN 809:2012-10
DIN EN ISO 12100:2011-03
DIN EN ISO 13857:2020-04

Fire Department Standard: DIN 14427:2013-12

Mr. Ralf Rennwanz is authorized to compile the technical documents.

Crane Process Flow Technologies GmbH
Heerdter Lohweg 63 – 71
40549 Düsseldorf

Place, Date: Düsseldorf, 25.11.2022

Signature of manufacturer:

A handwritten signature in black ink, appearing to read 'ppa.' followed by a stylized signature.

Information of signatory: Christian Gunske, Vice President / General Manager
Pumps

**This is the translation of the original declaration of conformity
for ELRO Peristaltic Pumps series GUP and GP.**



EU-Declaration of Conformity

in compliance with the terms of the Directive 2014/34/EU for equipment and protective systems intended for use in potentially explosive atmospheres

The Manufacturer: Crane Process Flow Technologies GmbH
Heerdter Lohweg 63-71, D-40549 Düsseldorf,
www.elropumps.com

declares that the pump units manufactured in series production

Description: ELRO Peristaltic Pump
Series: GUP 3-1,5 as well as GP20/10Ex
Pump hose materials: NBR, CSM, NR
all hoses are electrically conductive
Connecting ports: Stainless Steel, Bronze, PP electrically conductive
Base Frame: fire brigade carrying frame in stainless or galvanized steel
Pulsation damper: Stainless steel with CSM diaphragms electrically conductive
Suction- / Pressure hoses: electrically conductive
Drums and suction accessories: Stainless steel
Drives: All drives have their own declaration of conformity issued by the supplier
Installed electrical components: All installed electrical components have their own declaration of conformity issued by the supplier

in the version delivered by us, is in compliance with the following applicable regulations:

EU-Directive: Directive 2014/34/EU for equipment and protective systems intended for use in potentially explosive atmospheres
**Conformity-
Assessment procedures:** Equipment group II, Category 2G, Explosion group IIB
Temperature class T3, Equipment Protection Level (EPL) Gb
Harmonised Standards: DIN EN 1127-1:2019-10
DIN EN ISO 80079-36:2016-12
DIN EN ISO 80079-37:2016-12
Fire Brigade Standard: DIN 14427:2013-12

Place / Date: Düsseldorf, 25.11.2022

Signature of Manufacturer:

A handwritten signature in black ink, appearing to read 'ppa.', followed by a stylized signature.

Information on Signatory: Christian Gunske, Vice President / General Manager Pumps

Table of contents

	Page
1.0 General	7
1.1 Warranty	8
1.2 Transport, storage	8
1.2.1 Packaging and electrical equipment	9
1.3 Function	9
2.0 Safety	11
2.1 General	11
2.1.1 REACH information on SVHC substances	12
2.2 Intended use	13
2.2.1 Unintended use	13
2.3 Operation of pump	13
2.4 Conversions and alterations to the pump	13
2.5 Symbols and notes on safety	13
2.6 Maintenance work.....	14
2.6.1 Health and safety information on electric equipment.....	15
2.6.2 Health and safety information for work on pressure lines	15
3.0 Notes on application	16
3.1 Points to be observed before use.....	16
3.1.1 Pump suction power.....	16
3.2 Installation and connection	16
4.0 Operating instructions	17
4.1 Points to be observed before start-up	17
4.1.1 Filling the transport drum	17
4.1.2 Transport drum as dirt separator	18
4.2 Control elements	18
4.2.1 Connecting the pump to the electric power supply	19
4.2.2 Switching the pump on and off	19
4.2.3 Commissioning	19
4.2.4 Use of the pulsation damper	19
4.2.5 Transfer of highly liquid hazardous fluids	20
4.2.6 Pumping of highly viscous pulpy product	20
4.2.7 Taking up of contaminated fluid residues	21
4.2.8 Taking up of thin fluid films	21
4.3 Taking out of service	22

	Page
5.0 Maintenance	23
Standard design (spare parts list)	24
5.1 Cleaning	26
5.2 Replacing the pumping hose	27
5.2.1 Removing the old pumping hose	27
5.2.2 Inspecting the inside of the pump	28
5.2.3 Installing the new pumping hose	28
5.3 Replacement of separating part	29
5.4 Replacement of abutment	30
5.5 V-belt drive	30
5.5.1 Axial locking of the pulleys	30
5.5.2 Checking the tension of the V-bel.....	30
5.6 Oil change.....	30
5.6.1 Oil types for pump housing	30
5.6.2 Gearbox.....	30
5.6.2.1 Oil type for gearbox	31
5.7 Shaft bearing	31
6.0 Spare parts	31
6.1 Spare parts storage.....	31
6.2 Ordering spare parts	31
7.0 Troubleshooting	32
8.0 Technical data	33
9.0 Appendix	34

1.0 General

ELRO® Peristaltic pumps GUP 3-1.5 as well as GP20/10Ex are dimensioned as pumps in accordance with chapter 1, article 1, section (2), paragraph (j), point (ii) of the pressure equipment directive and are therefore no pressure equipment as defined by the EC pressure equipment directive 2014/68/EEC.

The following instructions refer to the pump for hazardous materials GUP 3-1,5 acc. to DIN 14427 and GP 20/10Ex.



Caution!

Since the pumps will be used in combination with other assemblies, such as motors, you must also strictly observe and comply with the operating and maintenance instructions for these components as well as the corresponding notes on safe and reliable operation.

These on-hand instructions contain information for installation, operation and maintenance of ELRO pumps for hazardous materials.

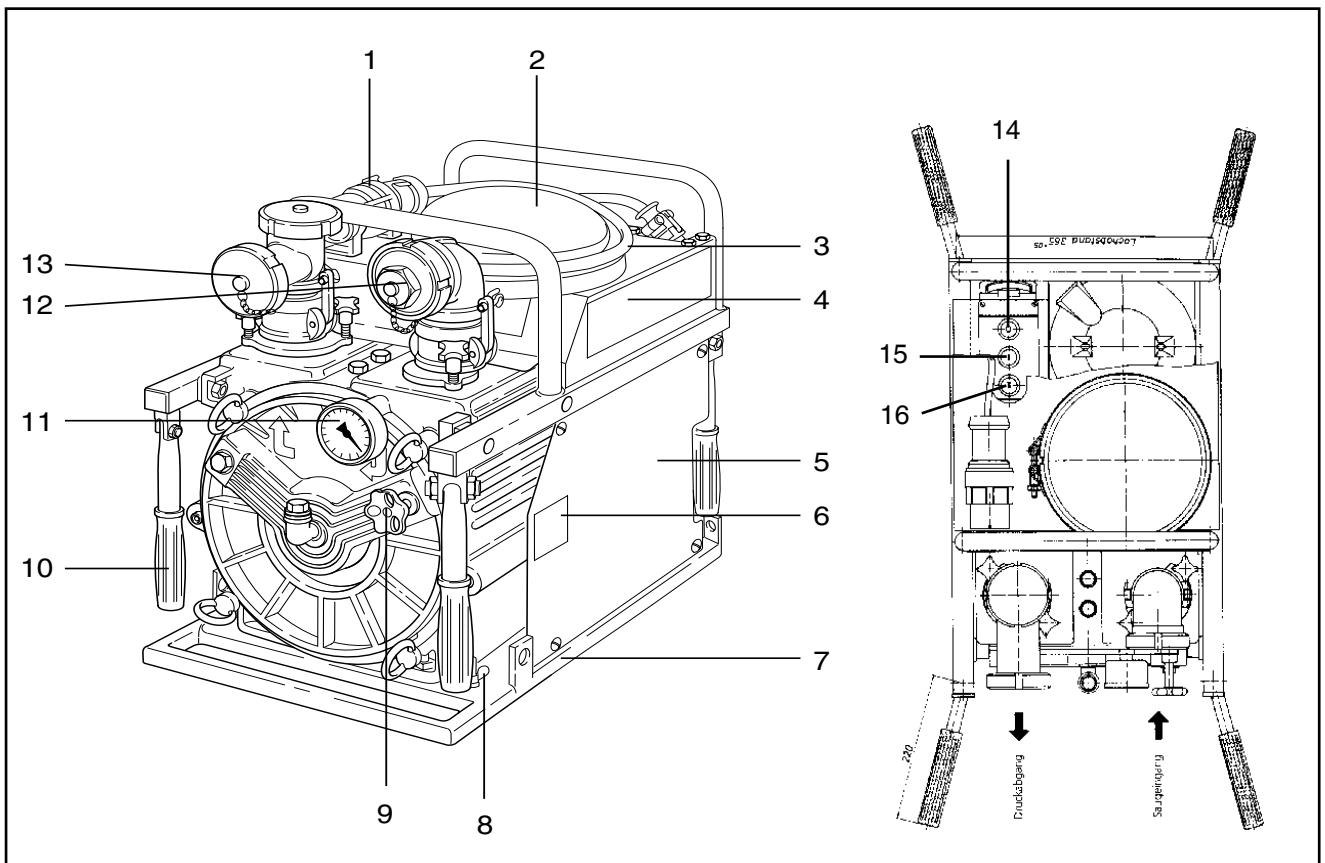

Fig. 1 Schematic design of pump for hazardous materials GP20/10Ex:

- | | | | |
|---|-------------------------------|----|--|
| 1 | Mains plug with holding clamp | 10 | Carrier handle, foldable |
| 2 | Pulsation damper | 11 | Vacuum gauge |
| 3 | Connecting cable 1.5 m | 12 | Connecting socket, suction side |
| 4 | Concise instructions | 13 | Connecting socket, pressure side (T-fitting) |
| 5 | Protective covering | 14 | Off-switch |
| 6 | Identification plate | 15 | On-switch, speed range I |
| 7 | Carrier frame | 16 | On-switch, speed range II |
| 8 | Connection for ground strap | | |
| 9 | Dosing valve | | |

Pumps for hazardous materials GUP 3-1,5 and GP 20/10Ex

You should therefore thoroughly read these instructions before use and always follow the information contained therein.



All personnel involved in activities on pump or equipment associated with the pump must have read this manual, especially the chapter "Safety" before starting work. This is too late once work has started. This applies especially for persons who work on the pump only occasionally, e.g. for maintenance and cleaning work.

You should always bear in mind that a correct function, a long lifetime and optimal operational reliability of the pump mainly depend on

- correct installation
- correct commissioning
- and proper maintenance.

Enquiries concerning service, spare parts or repairs should be addressed to the manufacturer or an authorized dealer.

Always provide the following information:

- Type
- Serial number of pump

This information is stamped on the identification plate on the outside of the pump.



When returning pumps or pump parts to the manufacturer or an authorized dealer for repair or overhaul, the delivery must be accompanied by a certificate stating that the pump is free of

product or other aggressive or hazardous substances.

1.1 Warranty

The correct function of each ELRO pump for hazardous materials is checked in the factory before shipment. The manufacturer assumes warranty for his product as specified in the effective terms of sales and delivery. Faults resulting from the non-compliance with the regulations and notes described hereunder can only be rectified at the cost of the customer.

1.2 Transport

In order to avoid any problems you should

- check the delivered goods against the delivery note for completeness and correctness,
- check whether the corresponding manual for the electric drive has been included.

Be careful when unpacking the pump and proceed as follows:

- Examine the packaging for transport damage.
- Take the pump carefully out of the packaging.
- Examine the pump for any visible damage.



Consider the indicated weight before attempting to lift the pump. Use only lifting gear of appropriate capacity.

Do not step or stand under suspended loads.

Description of safety symbols under Chapter 2.5.

Attach the lifting tackle so that the pump for hazardous materials can be safely lifted (Fig. 2).

Either fold out the carrier handles and carry the pump by these handles

or

attach carrier belts or ropes to the eyelets on the carrier frame and lift the pump with a hook.



Caution!

In order to avoid slipping of the sling the rope (belt) must be crossed over at the hook.

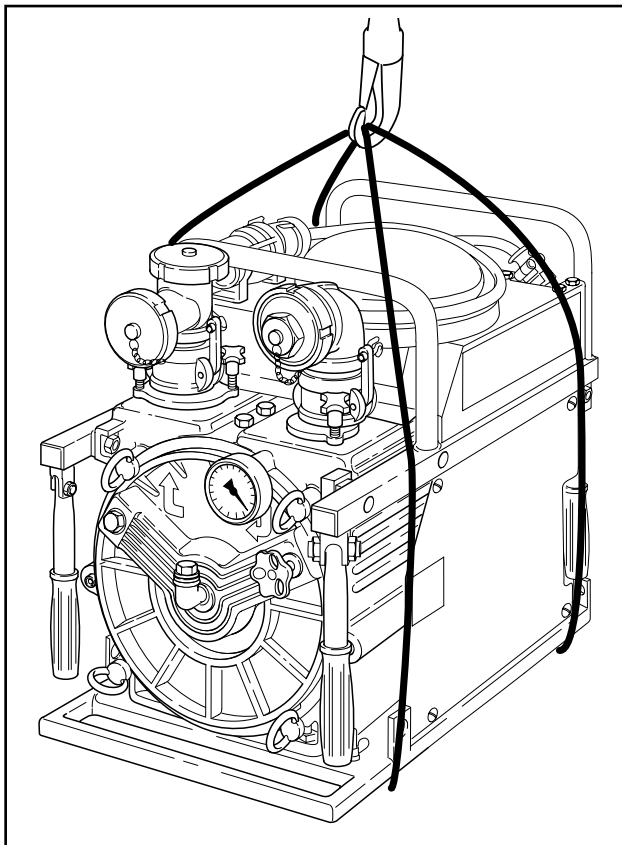

Fig. 2 Transport of the pump with lifting gear

1.2.1 Packaging and electrical equipment

We are happy to take back packaging and electrical equipment within Germany. Please contact us for this purpose.

1.3 Function

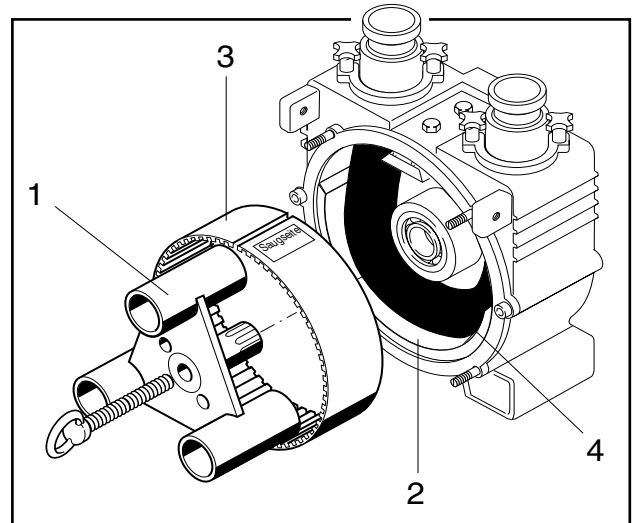

Fig. 3 1 Rotor 2 Abutment 3 Separating part 4 Hose

The priming properties of the peristaltic pump are based on the vacuum backed restoring forces of its hose. Due to its patented design a vacuum is permanently generated inside the hose on the suction side of the pump. This vacuum always restores the hose to its original size.

The abutment 2 (Fig. 3) is an elastomer part and is installed in the pump section where the hose is squeezed to maximum extend. This "soft contact base" of the hose prolongs its lifetime considerably.

At the same time this abutment protects the pump housing against damage caused by solid particles in case of a hose breakage. In case of wear the abutment can be easily replaced.

The separating part 3 (Fig. 3 and 5) separates the suction area (4, Abb. 4) from the inside of the pump (5, Fig. 4) and protects the pumping hose. In case of hose breakage it additionally protects the rotor (1, Fig. 4) against damage caused by abrasive or coarse particle product. The separating part can be replaced by simply unscrewing two screws.

The pump is filled with 1 litre of sliding fluid (glycerine or silicone), which works as lubricant, barrier and coolant.

The vacuum gauge connected with the suction area (4, Fig. 4) not only shows the present suction lift of the pump, but has the additional function of a warning instrument for possible defects. If the vacuum gauge does not indicate a vacuum during operation, the pump needs to be serviced urgently.

This maintenance can be carried out without any special tools.

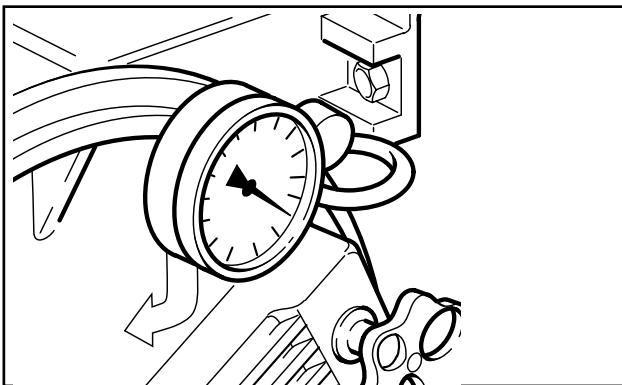

Fig. 4 Vacuum gauge

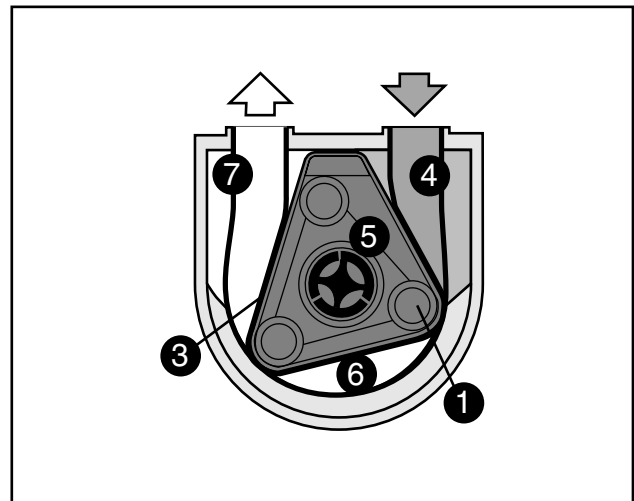

Fig.5

1 Rotor	5 Inside of housing
3 Separating belt	6 Hose chamber
4 Suction area	7 Pressure area

The rotor (1, Fig. 5) rotates inside the separating part (3, Fig. 5), which is tightly bolted to the housing. This separates the suction area (4, Fig. 5) from the inside of the pump (5, Fig. 5).

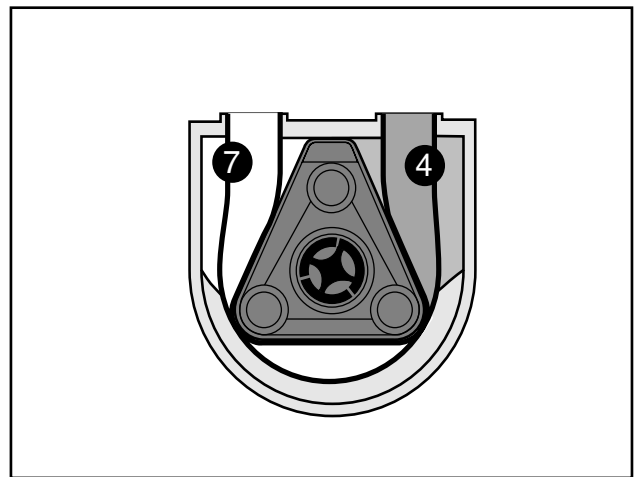

Fig. 6

4 Suction area
7 Pressure area

The sliding tube of the rotor enlarges the volume of the suction area (4). At the same time the pressure area (7) is decreased and the air is forced out through a channel in the pump cover.

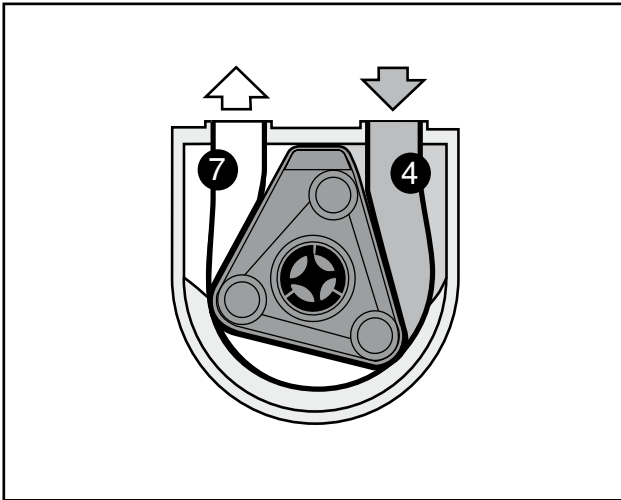

Fig. 7 4 Suction area
7 Pressure area

As the rotor rotates further the suction area becomes bigger. The fast rotation of the rotor generates a permanent vacuum of down to -1 bar (Fig. 7).

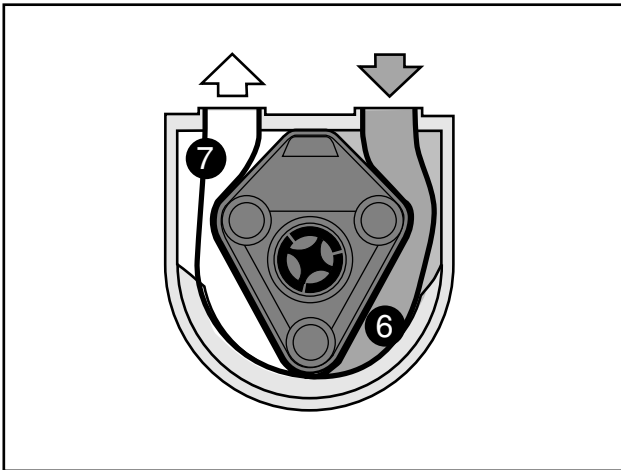

Fig. 8 6 Hose chamber
7 Pressure area

Since the hose chamber (6, Fig. 5) remains constant, the pressure area (7, Fig. 5) is decreased by the rotation of the rotor, which results in a volumetric pumping process (Fig. 7).

2.0 Safety

2.1 General

Please make sure that the pump is used for hazardous materials in compliance with applicable national safety regulations.

For HAZARDOUS MATERIAL APPLICATIONS the pump must only be started up and used by trained and professional persons and only in the permitted environment.

The pump must only be used outside or in well ventilated rooms.

Due to its excellent suction power the pump for hazardous materials can be used in explosion endangered environments, when keeping a safe distance to the danger source.



Hazard!

The reliable discharge of electro-static charging, which may occur during pump operation, must be assured.

The electric supply cable to the pump must be fitted with an explosion protected coupling socket for 380 - 415 V - 16 A (3P+N+PE), type of protection EEx de II CT6 such as: CEAG-GHG 531 3506 VO (matching explosion protected plug: CEAGGHG 531 7506 VO).

The sense of rotation of the electric motor required for operation of the pump must be assured by correct polarity from the factory and should be marked with an arrow on the motor housing (rotary field clockwise acc. to DIN VDE 0530 T1).

The pump has been designed for connection to electric control cabinets acc. to DIN 14686 or power generators acc. to DIN 14685 or DIN 14688.

Important protections for operating personnel:

If the operating voltage should fail for some reason while the pump is running, the pump control ensures that the pump will not automatically start again after the voltage supply has been re-established. The pump must in such a case be restarted by actuating the switch.

Due to its robust design this highly insensitive pump for hazardous materials is able to pump abrasive, viscous or pulpy materials mixed with solids.

The pump for hazardous materials GUP 3-1,5 is generally equipped with a Hypalon (CSM – electrically conductive) hose.

The GP 20/10 Ex can alternatively be fitted with a Nitrile (NBR) hose for oil fighting applications.

The new Hypalon (CSN) pumping hose is most suitable for the transfer of pumped products as mentioned in the compatibility list.



After each use with hazardous materials of this kind the pumping hose must be replaced for safety reasons.

After each use and before changing the hose the pump must be thoroughly flushed and completely drained. The mixing of certain pumped media may otherwise cause dangerous chemical reactions.

Always observe all applicable accident prevention instructions and implementing regulations.

The following precautions must be applied before performing maintenance work.

If the product to be pumped is a hazardous or noxious substance, the system must be

neutralized and vented



Danger or burning

Depending on operating conditions the pump may reach temperatures too high to touch.

You should therefore switch off the pump and let it cool down before touching it.

- Disconnect the pump for hazardous materials from the electric power supply (pull out the mains plug)
- Depressurize the pump head, i.e. relieve suction and pressure lines

It is not permitted to run the pump after removing the pump cover. When cleaning the pump manually make sure that all necessary precautions have been applied.

All incorrectly installed, unprofessionally operated or insufficiently serviced machines and pumps are potential safety hazards.

The non-observance of relevant safety measures may cause injury to operating personnel or damage to the pump. The safety covering must be properly reassembled before restarting.

The pump must be shut down or should not be restarted if any defects are found which could affect the operating safety and reliability of the pump.

2.1.1 REACH information on SVHC substances

According to the European Chemicals Regulation (EC) No 1907/2006 concerning the Registration, Evaluation, Authorisation and Restriction of Chemicals (REACH, Article 33), the following ELRO peristaltic pumps brass components may contain a lead content of more than 0.1%:

Pump connection couplings and pipe bends, as well as fittings for the vacuum system. Also the dosing valve of the M300 and the earthing

screws.

This information is based on declarations from our suppliers and, in part, on material declarations and analyses based on a risk-based approach in accordance with IEC DIN EN 63000.

2.2 Intended use

The explosion protected portable pump for hazardous materials is intended for taking up and transferring of aggressive fluids of classes 3, 6.1 and 8 of the "Gefahrgut-Verordnung-Straße" (GGVS)¹⁾ and is also suitable for the transfer of mineral oil products and other combustible products of EXPLOSIVE GROUPS II A and II B with ignition temperatures higher than 200 °C²⁾.

It is designed for mobile application and temporary operation (up to max. 5 hours).



Warning!

Check the pumping capabilities of the medium (freezing point) before commissioning.

In explosive environments the pump is only approved for zone 1³⁾.



Warning!

Not approved for use in zone 0! Fluids with an ignition temperature of less than 200 °C must not be pumped! All connected pipes, components and hoses must be electrically conductive (leakage resistance <1 mega ohm meter; Surface resistance <1 giga ohm).

Temperatures

The permissible ambient temperature range is -20 °C to +40 °C.

For permissible operating temperatures of the pump hoses refer to chapter 3.0.

¹⁾ Directive concerning domestic and cross-border transport of hazardous materials by road (published in federal legislation part 1). (Ecomed Verlag GmbH, D-86899 Landsberg/Lech)

²⁾ Definition of explosion groups and temperature classes see EN 50 014 (Beuth Verlag GmbH, D-10787 Berlin 30).

³⁾ Definition of zones see directive concerning

electrical equipment in explosion endangered rooms: ElexV (Carl Heymanns Verlag KG, D- 50939 Köln 41).

The pump is designed for mobile use and for short-time operation (up to max. 5 hours).



Warning!

Wear your personal protective clothing (full protection) before pumping hazardous material.

2.2.1 Unintended use

The operating safety and reliability of the supplied pump can only be assured if it is used for the purpose it is intended for. The limits mentioned in the technical data sheet must not be exceeded under any circumstances.



Caution!

It is not permitted to operate the pump with insufficient lubricant. For the fill level, refer to Ch 5.6. It is not permitted to operate the pump for more than 0.5 h without medium to be pumped.

2.3 Operation of pump

The pump must only be authorized persons.

Any responsibilities must be clearly appointed before starting operation and should always be complied with.

2.4 Conversions and alterations to the pump

Conversions and alterations to the pump are strictly prohibited.

However, this does not include minor changes, which do not affect safety and reliability, or measures, which even enhance the safety. Safety installations must not be made ineffective or changed or used in a way contradicting their purpose.

2.5 Symbols and notes on safety



Hazard!

Note on danger, which, if not observed, may lead to severe injury or even death.



Warning!

Note on danger, which, if not observed, may lead to sever injury or even death.



Caution!

Note on danger, insecure handling and working procedures may cause injury or extensive damage to equipment and property.



Warning – dangerous electric voltage. Contact with live parts can cause immediate death.

Doors and covers (e.g. hoods and lids) marked with this sign must only be opened by "specialists or/and instructed persons" after the respective operating voltage (input terminal voltage, operating voltage or external input voltage) has been switched off.



Operating safety of equipment at risk.

The non-observance of this note affects the operational reliability and can lead to pump damage.

Attention!

In this manual the Attention symbol precedes all safety notes referring to instructions, regulations or work sequences, which must be strictly complied with:

In this manual these symbols are used to highlight notes on possible dangers.

2.6 Maintenance work

Maintenance work must only be performed by qualified and specially instructed persons. This applies particularly for all work on electric, hydraulic and pneumatic equipment.

Keep unauthorized persons away from the pump.

Mechanical and electrical repairs and maintenance work must only be carried out by qualified specialists. The professional execution of this work must be examined and approved by a highly skilled and responsible "Inspector".

Before starting repair and maintenance work the equipment must be switched off and shut down and secured against unintended or unauthorized restarting.

Before starting work on electrical systems and equipment make sure that the system is reliably de-energized.

Apart from this the pump for hazardous materials must be reliably secured against unexpected restarting.

■ Pull out the mains plug

The customer (or an "authorized person" appointed by him) is responsible for the compliance with all accident prevention instructions applicable at the place of use.

As a measure to avoid injury all maintenance, adjustment and repair work should only be carried out using permitted and appropriate tools and working aids.

Blown fuses must not be repaired or bridged and may only be replaced by fuses of the same type.

Cooling facilities, such as ventilation slots, must not be made permanently ineffective.

Rotating or moving parts must be reliably stopped before starting work. It must be assured that these parts will not start to move while work is in progress.

Do not touch rotating parts and always keep a safe distance to avoid clothing or hair being caught.

Always wear protective clothing suitable for the job and the related dangers.

This applies especially for cleaning, maintenance and repair work. Depending on the type of work to be performed sufficient protection may be provided by e.g. wearing the following protective clothing: Protective goggles, ear defenders, working boots, safety gloves, etc.

Protective clothes should be of tight fit.

If your face could come in contact with chemicals, metal splinters or dust during work, you should wear a full face protection with safety goggles.

Always wear safety boots if there is a risk of heavy objects tipping over, slipping or coming loose for any other reason, thereby causing danger for your feet.

2.6.1 Health and safety information on electric equipment

Depending on the version, the pumps may be equipped with electronic accessories (controls, motor drives).

Severe damage to health and property can be caused by:

- non-permitted removal of covers
- unprofessional use of pump
- inadequate maintenance

Before starting installation work on electrical equipment this equipment must be reliably de-energized.

Cover non-insulated live power lines and plug connections against unintended contact.

Electric components stored and not used for a longer period of time should be carefully inspected before use, to ensure that the

insulation is still intact.

On wet electric assemblies or components parts, which would be perfectly de-energized in dry condition, may still be live.

Before touching damp or wetted electric components check by measuring whether parts that could be touched are still live.

Do not attempt to insert any objects through the openings on pump or attached equipment. This may cause short circuit and electric shocks with danger to life.

2.6.2 Health and safety information for work on pressure lines

Always relieve the pressure before starting work on pressure lines.

- Close shut-off valves
- Vent pipelines



Be careful when checking for leaks on pressurized lines. Fluids or air escaping under pressure can penetrate clothes and skin.



Be careful when loosening or changing pressure lines; lines mixed up by mistake may reverse the function.

Take care when handling hazardous (caustic, harmful) fluids.

- Always wear your personal protective outfit (e.g. gloves, goggles, tight fitting clothes).
- In case of skin contact, inhalation of harmful vapours or eye injury you should immediately contact a physician.

3.0 Notes on operation

3.1 Points to be observed before use

The pump must only be used by professionals and in compliance with the safety regulations (see chapter 2).

1. Before start-up make sure that the pump is in perfect condition.

The pump must only be operated in upright position with suction and pressure ports pointing up.

2. The pump is delivered ready for operation. In order to avoid friction heat and to save the pumping hose the pump is filled with 1 litre of silicone oil.
3. Check the pump arrangement to ensure that suction lift and discharge head are not exceeded.

3.1.1 Pump suction line

1. If the fluid to be pumped contains solid particles with a size of more than 8 mm, a filter, e.g. flat suction box, suction strainer should be used. This filter must be permanently monitored and cleaned.

3.2 Installation and connection

The pump unit must be placed on a level base of sufficient load bearing capacity for the weight of the pump.

Since the pump is a positive displacement pump it must be assured that no shut-off elements are installed in the pressure side.

Pump for hazardous materials GUP 3-1,5 acc. to DIN 14427

The pump is fitted with Camlock quick couplings DN 50 (male part) for the connection of hoses.

The matching couplings on **suction side** consist of:

Camlock coupling DIN 2828, DN 50 (female part)

Elbow, 90° pressure gauge, DN 50 for chemical applications

screw fitting, DIN 11851, DN 50 (female part)

Blanking plug DIN 11851, DN 50 with chain

on **pressure side** of:

Camlock coupling DIN 2828, DN 50 (female part)

T-union with two times DN 50

Male part and two blanking caps with chain DIN 11851

All connecting fittings are made of material V4A (1.4571). The pump for hazardous materials GP 20/10 Ex can alternatively be equipped with Storz couplings C or tank truck couplings. ELRO pumps for hazardous materials GUP 3-1,5 and GP 20/10 Ex are provided with motor protection switch, Off-switch and two-stage On-switch (stage I and stage II).

4.0 Operating instructions

4.1 Points to be observed before commissioning

Please check:

- whether the pump is correctly installed and connected.
- whether the sense of pump rotation is correct.

The sense of rotation is "clockwise" (when viewed from the drive). An arrow on the electric motor marks the sense of rotation

- that the pump is only used in the permitted explosion zone.
- whether the pumping hose inside the pump is suitable for the product to be pumped.
- that all safety installations are fastened and fully functional.

- whether the pump is properly earthed to avoid electro-static charging.

4.1.1 Filling the transport drum

When taking up small fluid quantities, which are contaminated by solids, the pump for hazardous materials is used as vacuum pump for the transport drum. The contaminated fluid is directly pumped into the drum, the pump does not have any contact with the fluid. The installation must be made as shown in Fig. 9.

When filling, ensure that a pressure of 1 bar is not exceeded.

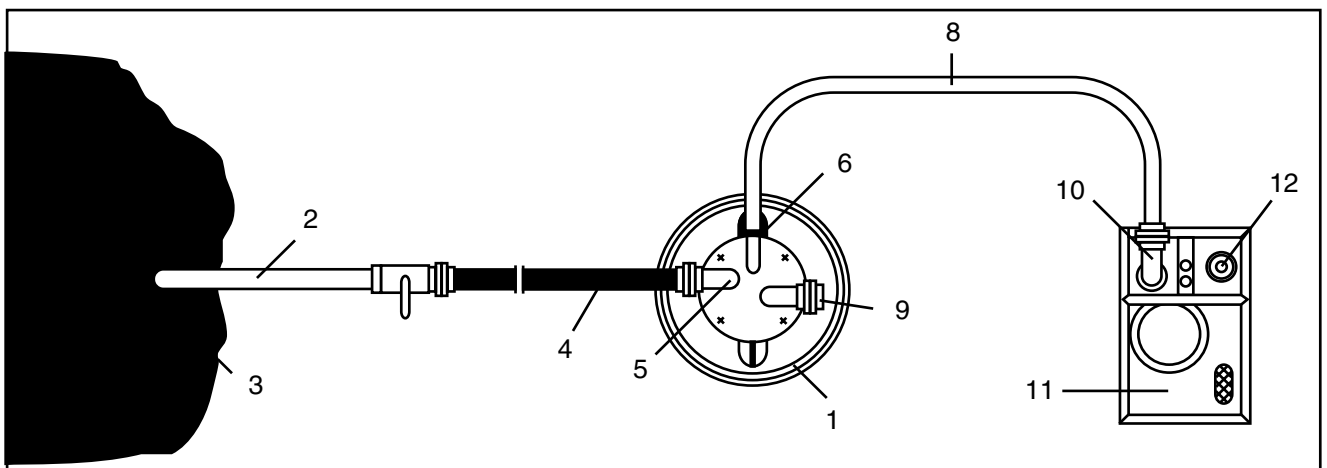

Fig. 9 Filling the transport drum

- | | | | |
|---|--|----|--------------------------------|
| 1 | Transport drum | 8 | Vacuum hose 1" |
| 2 | Special suction pipe 2" with straight-through ball valve | 9 | Suction port with blanking cap |
| 3 | Hazardous material | 10 | Suction port |
| 4 | Suction hose 2" | 11 | Pump for hazardous material |
| 5 | Suction port | 12 | use an air filter, if required |
| 6 | Air connection | | |

4.1.2 Transport drum as dirt separator

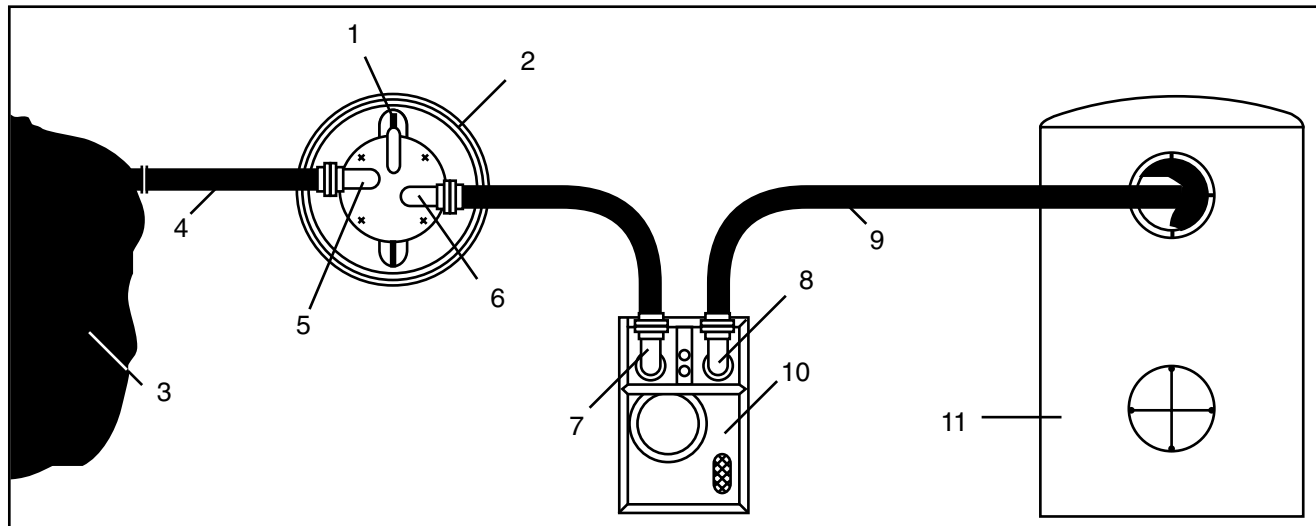

Fig. 10 Transport drum as dirt separator

- | | | | |
|---|---|----|-----------------------------|
| 1 | Air connection closed with blanking cap | 7 | Suction port |
| 2 | Transport drum | 8 | Pressure port |
| 3 | Hazardous material | 9 | Pressure hose 2" |
| 4 | Suction hose 2" | 10 | Pump for hazardous material |
| 5 | Suction port | 11 | Tank truck |
| 6 | Suction port | | |

If a tank truck is available to transport the hazardous material, the transport drum is used as a dirt separator. This enables to take up even the last residues of the hazardous material. Foreign matter is separated in the drum and thereby kept away from pump and tank. The installation must be made as shown in Fig. 10.



The peristaltic pump must not be operated against closed shut-off valves.

4.2 Control elements

The pump is operated via three switches on top of the pump.

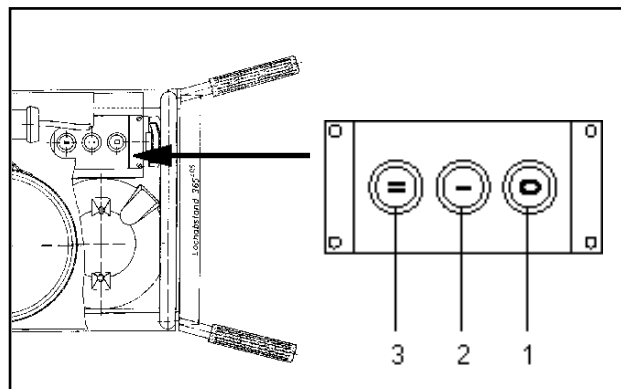

Fig. 11
 1 Off-switch
 2 Speed range I - On-switch
 3 Speed range II - On-switch

4.2.1 Connecting the pump to the electric power supply

The pump is connected to the electric power supply by means of a mains plug (see also Fig. 12).

Attention! Before plugging in the mains plug check whether the operating voltage complies with the specification on the identification plate.

Plug the equipment plug into the appropriate socket.

4.2.2 Switching the pump on and off

- Button 2 or 3 – press to switch on pump in speed stage I or II.
- Button 1 (Off-switch) – press to switch off the pump.
- From speed stage I you can press button 3 to change directly to the higher speed stage II.

Note:

If the operating voltage fails during operation the pump control prevents an automatic restarting of the pump after the operating voltage has been re-established.

The pump must be switched on by pressing button 2 or 3.

4.2.3 Commissioning

The vacuum gauge mounted to the pump housing shows the vacuum on the suction side. After a short time running the vacuum gauge should indicate vacuum. If no vacuum is reached, check the pump for leak tightness (see chapter maintenance and troubleshooting).

The flow rate can be regulated with the dosing valve on the front side of the pump (see Fig. 1 in the chapter "General").



Warning!

Start the pump only when wearing your personal protective outfit.

4.2.4 Use of the pulsation damper

The pulsation damper is fixed with a bracket to the top of the pump (Fig. 12).

When used with high pressures – max. 1.5 bar (long hoses) – it is recommended to mount the pulsation damper to the pressure side of the pump (T-fitting with blanking cap).

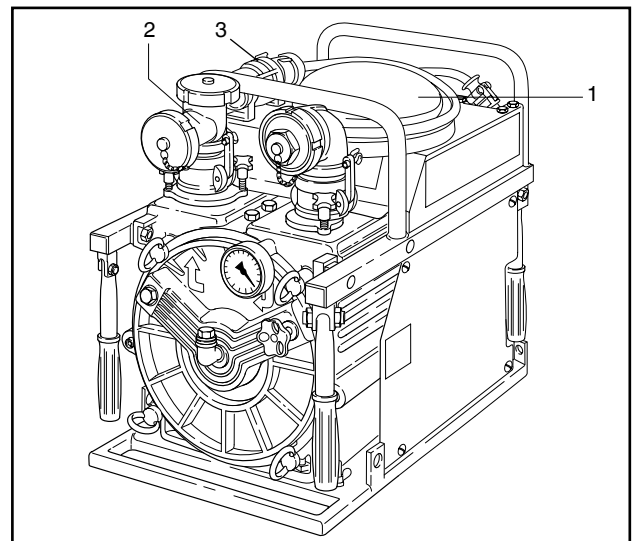

Fig. 12

- 1 Pulsation damper in transport bracket
- 2 T-fitting with blanking cap (for installation of pulsation damper)
- 3 Mains plug

For this purpose unscrew the pulsation damper from the transport bracket by turning it anti-clockwise. Remove the blanking cap from the T-fitting port pointing upward.

Turn the pulsation damper onto the free thread and tighten it.



Install the pulsation damper only with the pump switched off, tighten the clamping strap of the pulsation damper before starting operation.

4.2.5 Transfer of highly liquid hazardous fluids



Start the pump only when wearing your personal protective outfit.

Starting work

1. Connect and tighten the pulsation damper.
2. Connect suction and pressure hoses DN 50 for chemical applications.
3. Connect a stainless steel suction pipe to the suction hose.
4. Connect a stainless steel safety discharge pipe to the end of the pressure hose, min. DN 50.
5. Connect an earth strap to discharge electro-static charging.
6. Connect the electric motor and switch on speed stage I or stage II.
7. Watch the pressure gauge (the pointer must be in the negative sector).

Note:

The pump primes immediately without being filled.

In order to avoid overflowing of tanks when transferring fluids, the pump is switched to speed stage I and finally switched off when the filling limit is reached.



If a shut-off device is installed in the pressure side, this must always remain open when the pump is running.

4.2.6 Pumping of highly viscous pulpy product



Start the pump only when wearing your personal protective outfit.

Starting work

1. Connect and tighten the pulsation damper.
2. Connect suction and pressure hoses DN 50 for chemical applications (do not use corrugated stainless steel hoses).
3. Connect a special suction pipe to the end of the suction hose.
4. Connect a discharge elbow without shut-off device to the end of the pressure hose, min. DN 50.
5. Connect an earth strap to discharge electro-static charging.
6. Connect and switch on the electric motor (speed stage I).
7. Watch the pressure gauge on the suction socket.

Note:



If a shut-off device is installed in the pressure side, this must always remain open when the pump is running.

4.2.7 Taking up of contaminated fluid residues



Always wear protective clothing when starting the pump.

Starting work

1. Connect and tighten the pulsation damper.
2. Connect suction and pressure hoses DN 50 for chemical applications or pressure hose C 52-15 (do not use corrugated stainless steel hoses).
3. Connect the flat suction box to the end of the suction hose.
4. Connect a discharge elbow without shut-off device to the end of the pressure hose, min. DN 50.
5. Connect an earth strap to discharge electro-static charging.
6. Connect and switch on the electric motor (speed stage I).
7. Watch the pressure gauge.

4.2.8 Taking up of thin fluid films



Start the pump only when wearing your personal protective outfit.

Starting work

1. Connect and tighten the pulsation damper.
2. Connect a flexible plastic hose DN 32 to the suction port and acid resistant hoses DN 50 or pressure hose C 52-15 to the pressure port.

(Do not use corrugated stainless steel hoses.)

3. Connect the residue pick-up to the end of the suction hose.
4. Connect a safety discharge pipe without shut-off device to the end of the pressure hose, min. DN 50.
5. Connect an earth strap to discharge electro-static charging.
6. Connect and switch on the electric motor (speed stage II).
7. Watch the pressure gauge.

Note:

The pump primes immediately without being filled. With this residue pick-up even thinnest fluid films can be taken up, similar to a vacuum cleaner, and pumped into a transport drum for waste disposal, without intermediate storage.

End of work

1. Switch off the electric motor.
2. Thoroughly flush residue pick-up, hoses and pump with water adding a suitable cleansing agent.
3. Disconnect the hoses.
4. Lay the pump on its side with the pressure side down.
5. Switch on and run for 1-2 minutes to empty the pump completely.
6. Stop the motor.
7. Pull out the plug and disconnect the earthing strap.

8. Remove the pulsation damper.
9. Let all fluid residues drip off the couplings.
10. For easier cleaning of the pump you should use 2" foam rubber balls.

Attention! **Note: All residues resulting from the flushing of pump, hoses and accessories must be properly disposed of.**

4.3 Taking out of service

Attention! **Always observe the safety instructions in chapter 2 in this manual and the operating instructions for the drive unit.**

The shut-down of the pump for maintenance or cleaning work must only be performed by authorized and trained personnel.



Danger of cauterization

Clean the pump before taking out of service. Always wear your personal protective outfit.

1. Drain and flush the pump thoroughly.
2. Switch off the electric power supply and secure against unintended restarting.
3. Relieve the pressure in suction and pressure lines.



Fluids escaping under pressure can cause severe injury.

Take care when loosening pressure fittings, wear protective clothing.

Be extremely careful when handling hazardous fluids.

You should immediately consult a doctor if you had contact with such substances.

4. Loosen suction and pressure fittings carefully. The system may still be under pressure or tension.
5. Disconnect suction and pressure hoses from the pump.

If wear symptoms are detected when inspecting the pump, the respective parts must be replaced.

5.0 Maintenance

Attention! Always observe the safety regulations in chapter 2 when performing maintenance work!



Before beginning work on the this must be taken from the potentially explosive zone into a safe working area.



Caution!

Do not carry out tasks on pumps in the Ex-zone.

Work with the pump for hazardous materials requires special safety measures and reliable MAINTENANCE after every use!

We would like to draw your attention to the testing and operating instructions according to § 12 and 13; ElexV 1).

Before starting maintenance work the pump must generally be switched off and disconnected from the electric supply.

General maintenance is limited to a professional visual inspection. During this inspection special attention should be paid to affected components, loose connecting parts or electrical connections!

- Check equipment plug and connecting cable for tight fit and damaged.
- Defective cables and equipment plugs must only be changed by the manufacturer.
- Loose connections and damaged parts must be tightened and damaged parts must be changed (designation see spare parts list).
- Corroded parts must be protected by touching up the paintwork.
- Apart from this you must also ensure that the pump has been thoroughly

flushed and the pumped product completely drained (see operating instructions chapter 4.0: End of work)

We recommend the operator of the pump for hazardous material to keep a application and operation log, which provides evidence on operating hours of pump and pumping hose.

During general maintenance please check whether the pumping hose should be replaced for safety reasons (see maintenance instructions).

Accident prevention instructions (UVV) and fire fighting equipment regulations are specially emphasized.

Standard assembly (spare parts)

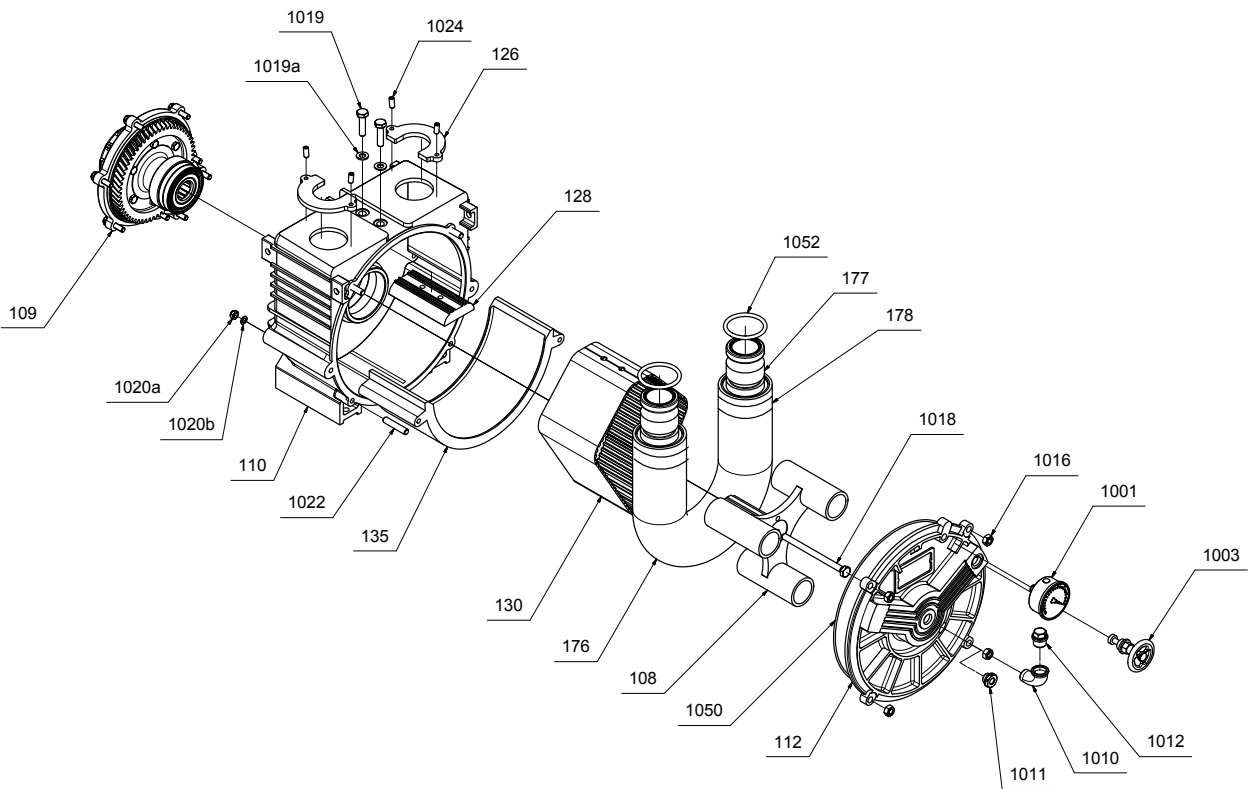

Fig. 13 - Standard construction (spare parts) - Pump head

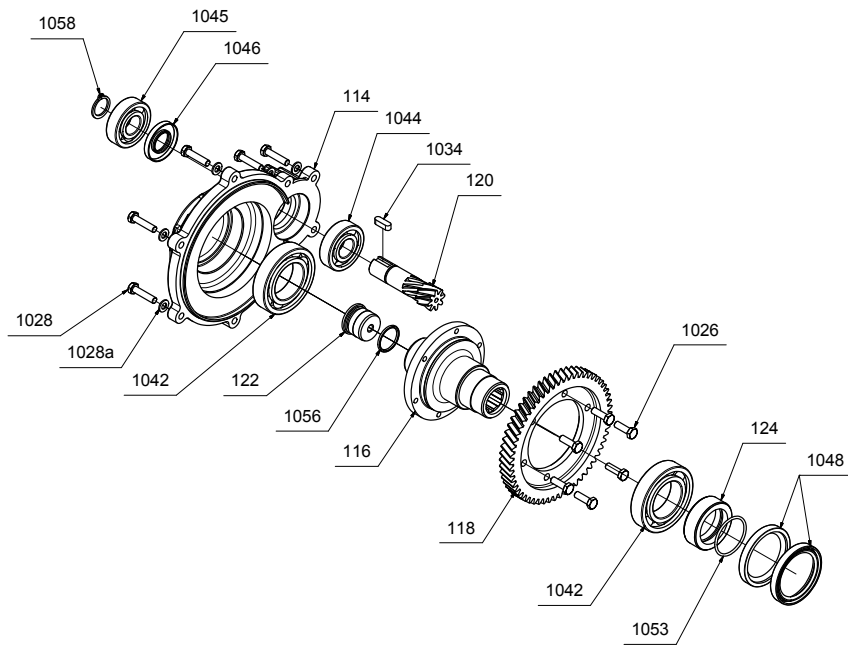

Fig. 14 - Standard construction (spare parts) - Gear unit

ELRO® Pumps for hazardous materials GUP 3-1,5 and GP 20/10Ex

Item	Designation	Stück / No. Req.	Bestell-Nr./ Order No.
108	Rotor	1	MP0302010-002
109	Gearbox complete	1	MP03036012-BG
110	Pump housing	1	MP0300003-400
112	Pump cover M300	1	MP0301004-400
114	Gearbox cover	1	MP0301105-420
116	Ring gear carrier	1	MP0303401-400
118	Ring gear	1	MP0303301-040
120	Pinion	1	MP0303501-040
122	Retaining nut	1	MP0303201-010
124	Inner ring	1	MP0303101-030
126	Retaining claw	2	MP0304104-110
128	Separator retainer	1	MP0305101-410
130	Separating part	1	MP0305001-580
135	Thrust bearing	1	MP0305401-500
176B	Pump hose, NBR	1	MP0306020-510
176C	Pump hose, CSM	1	MP0306022-560
177S	Connecting socket KL-VT, 1.4571	2	MP0304414-110
178	Hose clamp	2	EL740-004-001
1001	Vacuum gauge	1	EL807-100-000
1003	Dosing valve	1	EL823-300-320
1010	Elbow	1	930050-05
1012	Ventilation valve	1	EL823-300-001
1016	Hexagon nut	4	901000391
1018	Hexagon screw	1	900121991
1019	Hexagon screw	2	900160091
1019a	Washer	2	902000305
1020	Socket head cap screw	2	900210791
1020a	Hexagon nut	2	901040011
1020b	Flat ring seal	2	922109-24
1022	Grub screw	2	910300091
1022a	Hexagon screw	2	900162691
1024	Set screw	4	910002191
1026	Hexagon screw	6	900121191
1028	Hexagon screw	8	900150691
1028a	Washer	8	902000205
1034	Feather key	1	EL040-513-020
1042	Grooved ball bearing	2	EL2001011-010
1044	Grooved ball bearing	1	EL2001012-010
1045	Grooved ball bearing	1	EL2001013-010
1046	Shaft ring seal	1	EL104-012-510
1048	Shaft ring seal	2	EL104-013-510
1050	O-ring	1	920014741
1052	O-ring	1	920015641
1053	O-ring	1	920014641
1054	Paper gasket	2	EL120-001-920
1056	O-ring	1	920014541
1058	Circlip	1	902220606

The complete number is composed by combining the size and item no.

Example:

Pump hose NR for GUP:
176C

Order no.
MP0306022-560

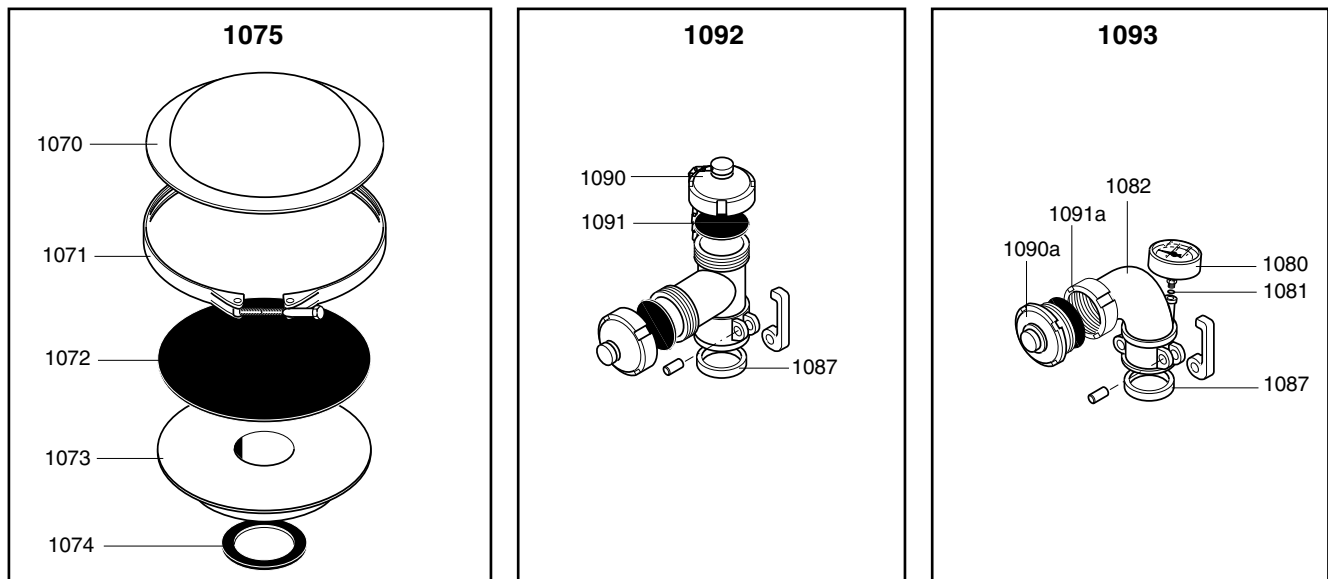

Fig. 15 – Spare parts/accessories – pulsation damper

Spare parts pulsation damper

Qty.	No.	Part-no.	Designation
1	1070	MP0321007-110	Damper housing
1	1071	MP0321000-BG	Clamping strap
1	1072	MP0321004-560	Diaphragm CSM
1	1073	MP0321010-110	Damper plate
1	1074	922402-40	Seal rings 50x78x4, FKM
1	1075	MP0321001-BG	Pulsation damper compl.

Spare parts for connecting port, pressure side

Qty.	No.	Part-no.	Designation
1	1087	922501-44	Seal rings 50x66, FKM
2	1090	EL703-014-100	Blanking cap with chain
2	1091	EL111-001-590	Sealing disc, FKM
1	1092	MP0323002-110	T-fitting GUP3-1,5-RV compl.
1	1092	MP0323008-110	T-fitting GUP3-1,5-TW compl.

Spare parts for connecting port, suction side

Qty.	No.	Part-no.	Designation
1	1080	EL807-700-100	Vacuum gauge -1/0/5 63
1	1081	922107-24	Flat sealing ring G 1/4
1	1082	MP0323101-110	Tube elbow GUP 3-1,5-RV
1	1082	MP0323103-110	Tube elbow GUP 3-1,5-TW
1	1087	922501-44	Seal rings 50x66, FKM
1	1090a	EL703-013-110	Blanking plug with chain (RV)
1	1091a	922405-44	Sealing disc, FKM (RV)
1	1093	MP0324007-BG	Tube angle GUP 3-1,5-RV compl.
1	1093	MP0324009-BG	Tube angle GUP 3-1,5-TW compl.

Pumps for hazardous materials require only minor maintenance. The gear in the pump head is lubricated by low viscosity oil (oil level inspection through oil sight glass, part-no. 1036).

The only wear items on the pump are:

Pumping hose, separating part, abutment.



Pumps with electric drive must be generally be switched off and disconnected from the electric power supply before starting maintenance work!

Attention! If the pump is used for aggressive, caustic or toxic media, the pump must generally

be flushed with a neutral agent before opening the pump housing.

5.1 Cleaning



Pumps used in potentially zones must be fundamentally kept free from dust deposits.

General notes:



Caution!

Always wear protective clothing when working with solvents or cleansing agents.

Housing, cooling fins, openings and covers on equipment components are very often

not just protections, but have additional functions such as cooling, insulation, noise reduction, splash protection, etc.

Some of these functions can be impaired or may become totally ineffective by excessive deposits of dirt.

Here some advice on how to remove dirt.

- Dried on dirt can be removed by scratching, scraping or brushing
- Minor dirt deposits, such as layers of dust and fine deposits can be wiped off, cleaned off with a vacuum cleaner, removed with a brush or broom

5.2 Replacing the pumping hose

The installed HYPALON hose is characterized by a high chemical resistance against most fluids.

By experience the chemical resistance of the hose is sufficient for the quantities involved in accidents with hazardous materials, even in extreme cases.

However, the resistance must be checked before the use with hazardous materials!

The pumping hose must generally be replaced after each use with hazardous material.

5.2.1 Removing the pumping hose

1. Switch off the pump and disconnect it from the electric power supply (pull out the mains plug)
2. Empty the pump hose completely.
3. Stand the pump with the pump cover facing forward. Place a container to collect the sliding fluid.

4. Loosen and unscrew four nuts (part-no.1016, Fig. 13) from the pump cover. Take off the washers.
5. Take the pump cover carefully off, let the sliding fluid flow into the container.



If the pumping hose is damaged, pumped medium and sliding fluid may have mixed. In this case the inside of pump housing and cover must be cleaned. After changing the hose the sliding fluid must be refilled.

6. Unscrew the rotor retaining screw (part-no. 1018, Fig. 116).

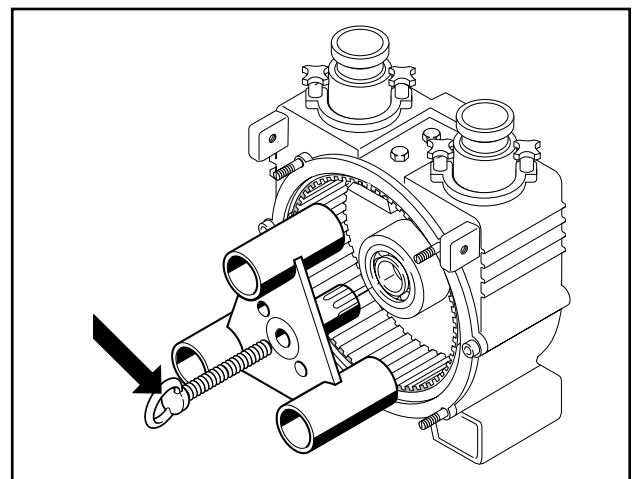

Fig. 16 Disassembly of rotor

Press off the rotor off by using the M10 forcing bores and the retaining screw (arrow Fig. 16).

7. Loosen and remove both holding clamps and pumping hose (Fig. 17).

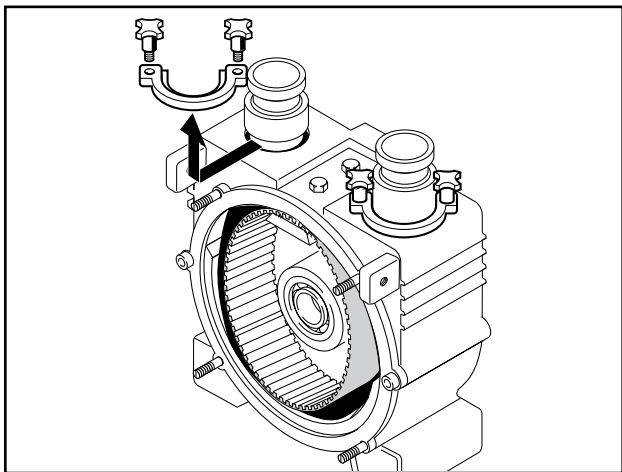

Fig. 17 Disassembly of holding claws

8. Pull the pumping hose on the pressure side back into the housing, then pull it back on the suction side and take it out (Fig. 18 and Fig. 19).

5.2.2 Inspecting the inside of the pump

Before installing a new pumping hose clean the inside of the pump housing and check for damage.

Replace damaged parts.

5.2.3 Installing the new pumping hose

The new pumping hose is installed in reverse order of disassembly.

1. The connecting sockets must be fastened to the hose by means of a hose assembly unit. Special hose clamps can be delivered instead of the clamping strap.

The hose must be pushed onto the socket, so that the end of the hose touches the collar around the complete circumference.

Each socket is fastened with one hose clamp.

In order to achieve an optimal clamping force the clamping strap must be placed

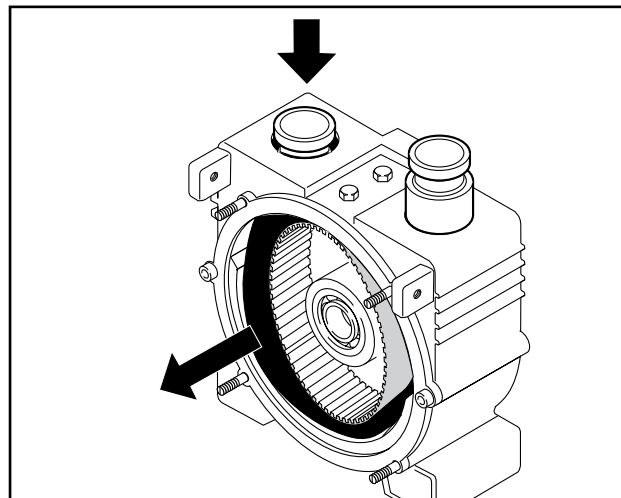

Fig. 18 Disassembly of pumping hose

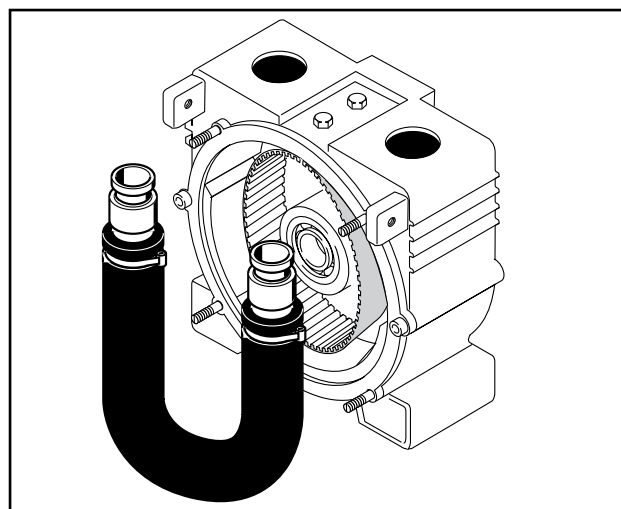

Fig. 19 Disassembly of pumping hose

around the hose twice and tightened.

After assembly the strap must be parallel to the end of the hose, on side of the loop (buckle) must be flush with the end of the hose.

Please make sure that the loops of the socket fastening on a hose are on the same side.

In the pump the sockets must be

assembled in such a way, that the loops are always furthest away from the rotor.

Notes on the correct use of the hose assembly unit can be found in the respective operating instructions.

2. Slide a new O-ring over each connecting socket.

Note: For easier assembly of the hose we recommend to remove the separating part.

3. Push one end of the hose into the opening on the suction side.
4. Insert the hose into the housing and push the other end through the opening on the pressure side.
5. Attach and tighten both holding brackets.
5. Assemble and tighten the rotor.
6. Stand the pump with the pump head facing upward.
7. Fill the housing with 1 litre of silicone oil M 350.
8. Lay a new O-ring on the pump cover.
9. Close the pump cover and tighten the screws crosswise.
10. Stand the pump up as normal

5.3 Replacement of separating part

The installed separating part has the function of creating the vacuum in the pump housing and provides a protective layer between rotor and pumping hose. When changing a hose the separating part should always be examined for possible damage. This should be done before installing the hose. If damaged it must also be replaced.

1. After removing the pumping hose loosen both hexagon screws (part-no. 1019, Fig. 13) on top of the pump so far that the split separating part can be taken out of the holder.

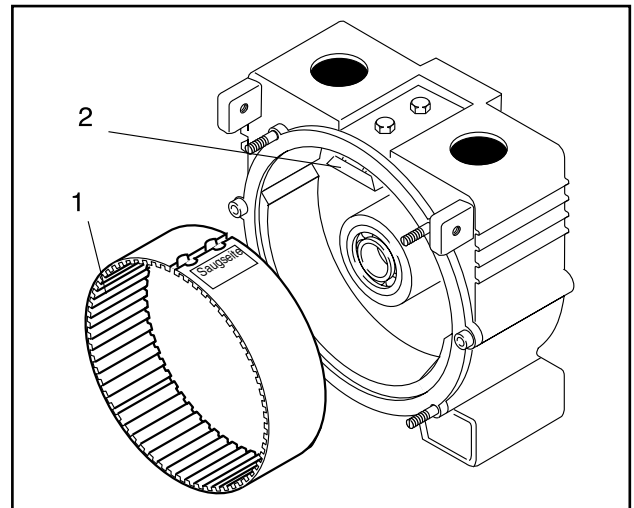

Fig. 20 Installation of separating part

- 1 Separating part
- 2 Holder for separating part

2. Insert the new separating part into the holder with the gearing towards the inside (Fig. 20).

Make sure that the separating part neatly rests against the housing wall and is flush at the joint.

3. Tighten by hand to allow the separating part to align itself.

Fasten the holder only after the pump cover has been assembled.



The separating part must rest properly against pump cover and back wall of housing.

5.4 Replacement of abutment

When replacing the hose you should also examine the abutment for damage

1. Remove both side plates from the pump carrier frame.
2. Unscrew both abutment fastening screws (part-no. 1020, Fig. 13) and remove the abutment from the housing (part-no. 135, Fig. 21).



Clean the housing thoroughly before assembling the new abutment.

Do not forget to assemble the copper sealing rings (part-no. 1020b, Fig. 13) with the abutment fastening screws.

5.5 V-belt drive

The installed V-belt has been designed for a power transfer of up to 3 kW under permanent operation.

5.5.1 Axial locking of the pulleys

In order to prevent the setscrews from loosening, use thread adhesive Loctite243 or Tuflok 180 when assembling.

5.5.2 Checking the tension of the V-belt

If the V-belt tension slackens (V-belt can be depressed for more than 1 cm), the V-belt needs to be tightened.

1. Remove both side plates from the pump.
2. Loosen four fastening screws on the motor foot.
3. Loosen the counter nut on the V-belt tensioning device and tighten the tensioning screw until the correct V-belt tension is achieved.

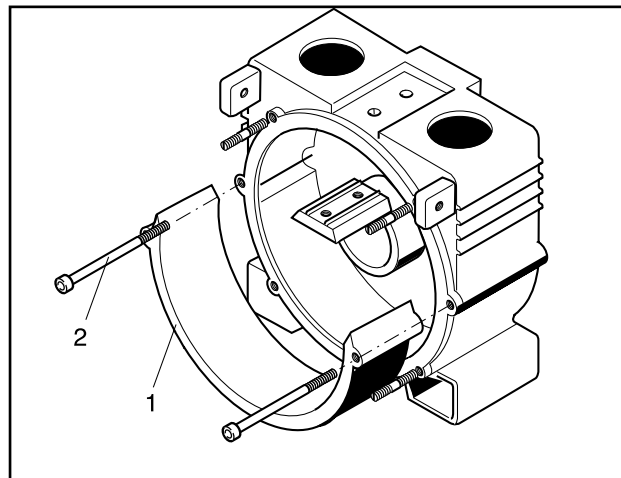

Fig. 21 Disassembly of abutment

- 1 Abutment
2 Abutment fastening screws

4. Lock the tensioning screw with the counter nut.
5. Tighten the fastening screws on the motor foot and make sure that the V-belt is properly aligned.
6. Reassemble the side plates.

5.6 Oil change

5.6.1 Oil types for pump housing:

We recommend to use the following oils:

Pump: Silicon EL420-001-BG

Glycerine EL430-001-BG

5.6.2 Gearbox:

The gearbox is lifetime lubricated by 0.25 litres of low viscosity oil.

The oil only needs to be changed in case of an oil loss.

5.6.2.1 Oil type for gearbox:

We recommend to use the following oils:

Gearbox: Renolin CLP100
Fuchs Europe GmbH

5.7 Shaft bearing

The shaft bearings are designed for an service life of a minimum of 15000 hours.

After this time, the bearings must be replaced by the manufacturer.

6.0 Spare parts

6.1 Spare parts storage

Since the extent of the recommended spare parts storage depends on the period of use and the different operating conditions for the pumps, you should consult the manufacturer or an authorized dealer.

6.2 Ordering spare parts

Please state the following when ordering spare parts:

- Pump type
- Construction year and serial number
- Spare parts article number

Should subsequent material changes for different parts of the pump have taken place, this information is mandatory. The required spare parts and their article numbers can be found in the spare parts lists.

These can be found under www.cranechempharma.com.

Liability when using non-genuine spare parts:

Installation and/or use of non-original spare parts or accessories can negatively alter and consequently impair the design-related features of the peristaltic pump. For damage caused by the use of non genuine spare parts and accessories on pump, system or product all liability and warranty is excluded.

7.0 Troubleshooting

Fault	Possible cause	Remedy
No pump flow	Pressure and suction valves closed	Open valves
	No operating voltage	Connect to voltage supply
	Wrong direction of rotation	Reverse the direction of rotation, check supply line (phase)
	Suction line blocked	Remove blockage
	Leaks in suction pipe (entering of air)	Find and eliminate leaks
	Suction lift too high	Change pump arrangement
	Excessive counter-pressure	Change pump arrangement, if necessary use different hose cross-sections
Pump loses suction power or insufficient pumping capacity	Leaks in suction pipe	Find and eliminate leaks
	Suction line blocked	Remove blockage
	Insufficient suction pressure	Change pump arrangement
	Worn pump parts, dosing valve open	Replace parts, close dosing valve
	Lubricant level in pump too low	Fill in lubricant
	Pump worn or defective	Examine, if necessary replace defective parts
	A certain heating of electric motors is normal	Check current consumption as a measure of safety
Drive heats up or is overloaded	Discharge pressure too high	Change pump arrangement

8.0 Technical data

The specified data are mean values, measured with water under normal operating conditions

	Stage II	Stage I
Nominal Delivery l/min.	300	150
Nominal pumping pressure bar	1.5	1.5
Nominal speed rpm	240	120
Motor power kW	2,75	2,1
Amperage A	6	4,8
Voltage V	380-415, three-phase current	
Type of protection	EEx eII cT3	
Motor	EEx deII cT6	
Circuit breaker	CEAG-GHG 531 7506 VO	
Equipment mains plug	CEAG-GHG 531 7506 VO	
Sense of rotation	Clockwise (see arrow)	
Couplings		
Suction side (female)	Tapered socket DIN 11851-DN 50	
Pressure side (male)	Threaded socket DIN 11851-DN 50	
Dimensions L x W x H mm	620 x 390 x 520 acc. to DIN 14427	
Weight, ready for operation kg	98	
Pumping hose, electr. conductive	CSM HYPALON	
	Stage I	Stage II
Sound pressure level L_{p_A} [dB]	65	66
Sound capacity level L_{w_A} [dB]	78	79
		DIN EN ISO 3744
		DIN EN ISO 3744

9.0 Appendix: Applicational recommendations

Rubber materials for pumping hoses

Designation	Properties	chemically resistant	conditionally resistant	not resistant	thermal use	Recommendation
Hypalon (CSM) Nitrile rubber NBR only for GP 20/10 Ex	Elastomer, created by polymerization of chlorosulphonated ethylene: wear resistant, electr. conductive, resistant against chemicals.	Acids and alkaline solutions, alcohols, paints, foaming agents, hot water, steam up to 120°C.	Gasoline, benzene, fuel oil, gear oil.	Solvents	- 20 to + 80°C	Fire brigade handling of hazardous materials
	Mixed polymerisate consisting of butadiene and acrylnitrile: wear resistant, oil resistant,	Mineral oil, alcohol, gasoline, kerosene, fuel oil, gear oil, water up to 100°C.		Benzene, acids and alkaline solutions, ester solvents.	-10 to + 80°C	Oil fighting

¹ The chemical resistances apply only for a product temperature of up to 20°C.

² Conditionally resistant means: sufficient for pumping quantities of up to 40 m³.

9.0 Appendix: Dimensions

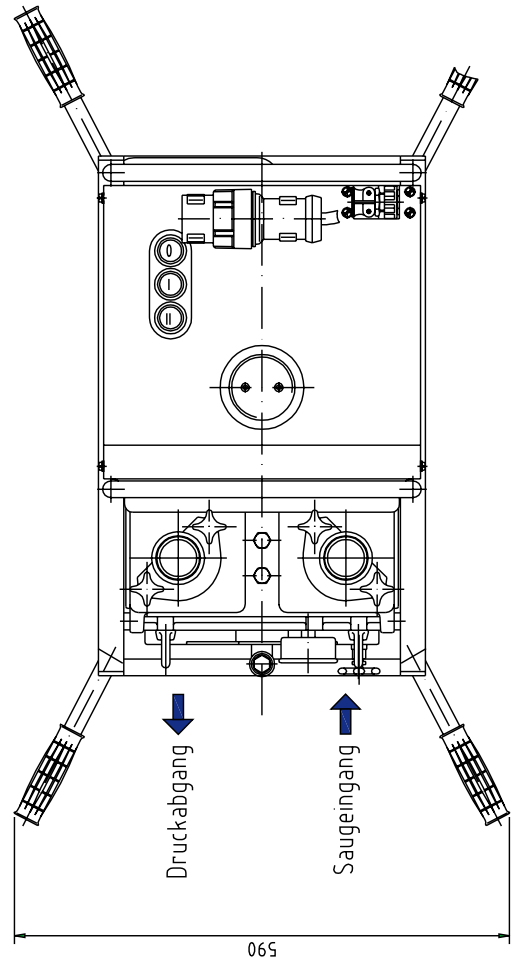
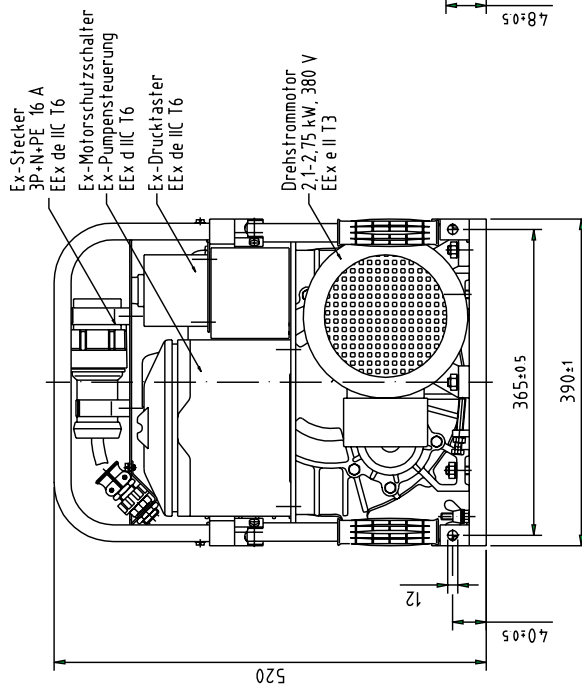
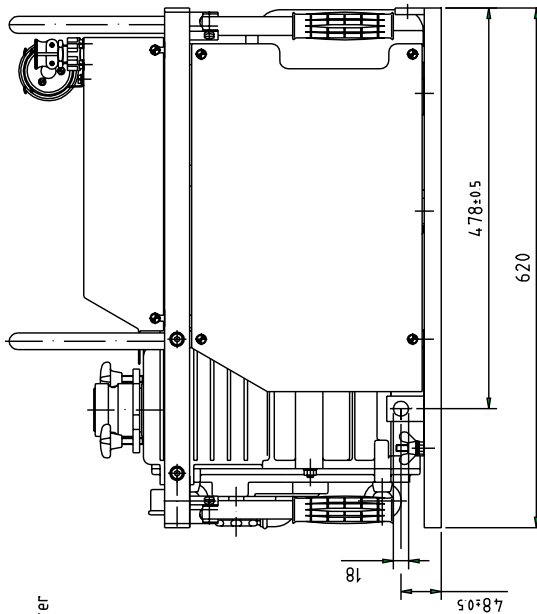
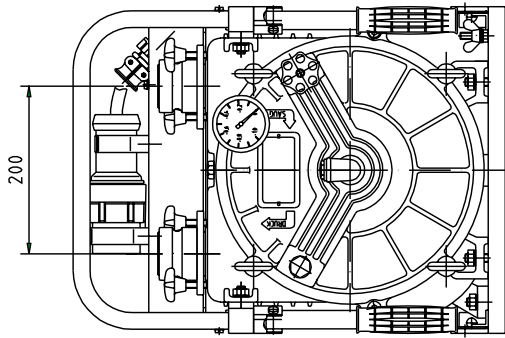

Note on Declaration of no Objection

We want to protect our employees against dangers through contaminated devices and allow the timely handling of your return.

Please understand that for this reason we can only accept your shipment upon submission of our declaration of non-objection including return number.

Upon our receipt of the filled-out declaration of non-objection, you will receive a return number from us.

Please affix the same then to the package so that it is readily visible from the outside.

Declaration of Harmlessness

Please send this declaration to your CPFT contact by Email or fax before sending the goods.

Crane Process Flow Technologies GmbH

Heerdter Lohweg 63-71
40549 Düsseldorf
Fax +49 (0) 211 5956 111
infoDus@cranecpe.com

We want to protect our employees, the employees of the transport companies and the environment as much as possible against any hazards from contaminated equipment. Therefore, please understand that we will only be able to carry out inspections/repairs after we have received this declaration, fully filled-in and signed. We cannot accept media samples.

Concerning the return dated _____

Delivery note No. _____

Pump type / spare parts _____

Drive type _____

With my legally binding signature I declare:

- that the returned pump/drive has been thoroughly cleaned and decontaminated before shipment,
- that the returned pump/drive will not pose any dangers caused by bacteriological, virological, chemical or radioactive contamination,
- that I am authorized to issue such declarations for the company concerned.

For repair service, we kindly ask you to supply us with the following additional information:

Detected defect

Which media have been used. Please provide UN/CAS number and safety data sheet.

Company stamp

Name _____

Position _____

Date/ signature

You can request the Declaration of No Objection from us via the contact mentioned below (infoDus@cranecpe.com).

ALOYCO • CENTER LINE • DUO-CHEK • FLOWSEAL • JENKINS • KROMBACH • NOZ-CHEK • PACIFIC • STOCKHAM • TRIANGLE
DEPA • ELRO • PSI • RESISTOFLEX • RESISTOPURE • REVO • SAUNDERS • XOMOX

Crane Process Flow Technologies GmbH, Heerdter Lohweg 63-71, D- 40549 Düsseldorf, Germany, infoDus@cranecpe.com
Local Court Düsseldorf, Germany, HR B 24702, Managing Director: Sascha Übelher-Späth

This is the translation of the original operating and installation instructions for ELRO Pumps for hazardous materials GUP 3-1,5 and GP 20/10Ex.

For the original version in German, please refer to www.cranepharmaceutical.com



Crane Process Flow Technologies GmbH

D-40512 Düsseldorf
Heerdter Lohweg 63-71, D-40549 Düsseldorf
Phone +49 211 5956-0
infoDus@cranecpe.com
www.elropumps.com
www.cranecpe.com

We reserve the right to change all technical information.

CRANE®