

RUBBER LINE DIAPHRAGM

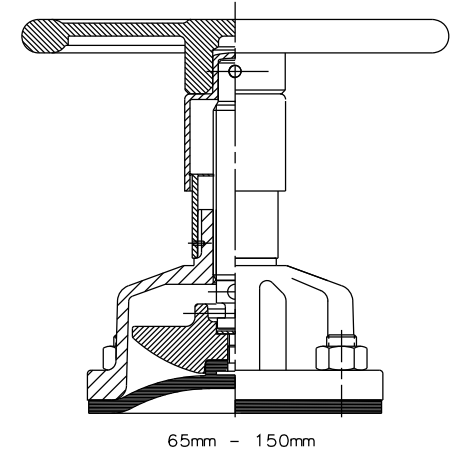

RUBBER/PTFE LINE DIAPHRAGM

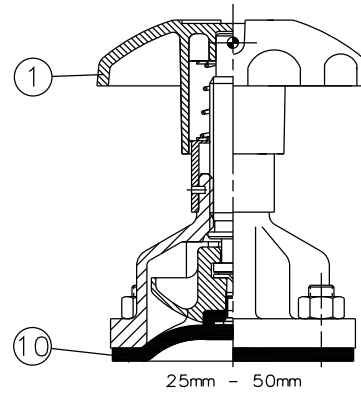
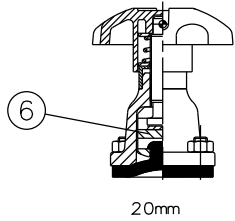
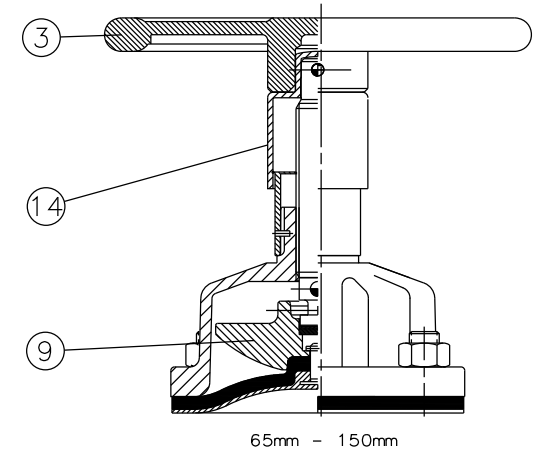
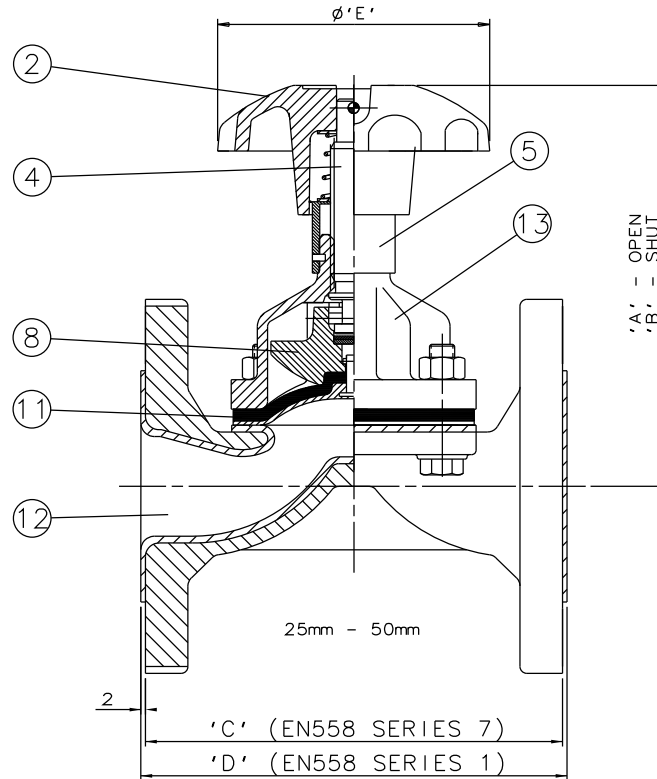
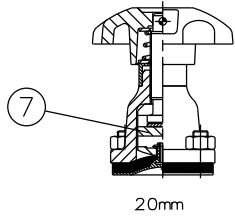

Item	Component	Material	Lining	Where Used
1	HANDWHEEL	ABS		20mm-50mm
2		CAST IRON		20mm-50mm
3		CAST IRON		65mm-150mm
4	SPINDLE	MILD STEEL		
5	BONNET SLEEVE	POLYPROPYLENE		
6	COMPRESSOR	MILD STEEL		20mm-20mm
7		SILICON ALUM.		20mm-50mm
8		CAST IRON		25mm-150mm
9		CAST IRON		65mm-150mm
10	LINE DIAPHRAGM	RUBBER		32 146 134 146 180 120
11		RUBBER/PTFE		40 160 143 159 200 120
12	BODY	CAST IRON	HARD RUBBER	50 177 153 190 230 120
		CAST IRON	SOFT RUBBER	65 229 197 216 290 170
		S.G. IRON	BUTYL RUBBER	80 247 212 254 310 230
		CAST STEEL	NEOPRENE RUBBER	100 311 265 305 350 280
13	BONNET	CAST IRON		125 391 325 356 400 280
14	HANDWHEEL BOSS	POLYPROPYLENE		65mm-150mm 150 445 370 406 480 368

The information on this sheet is Private and Confidential and is the property of Crane Process Flow Technologies Limited and must not be published directly or indirectly in any manner whatsoever without the written permission of the Company and must not be used in any way detrimental to their interests.  
© Crane Process Flow Technologies

<b>CRANE</b>	Process Flow Technologies A Crane Co. Company	<b>Saunders</b> The Science Inside	
Title GENERAL ARRANGEMENT OF 'A' TYPE RISING HANDWHEEL INDICATOR BONNET ASSEMBLY (9000) FITTED ON RUBBER LINED FLANGED BODY			
Drawn RI	Date 19.06.13	UNCONTROLLED IN HARD COPY FORMAT	
Checked RND	Date 19.03.13		
First Angle Projection Method E		DO NOT SCALE	Drawing No. 1 Issue. 1